

CMOD 103.43x61.00x61.00
CASE 810AA
ISSUE B

DATE 12 SEP 2025

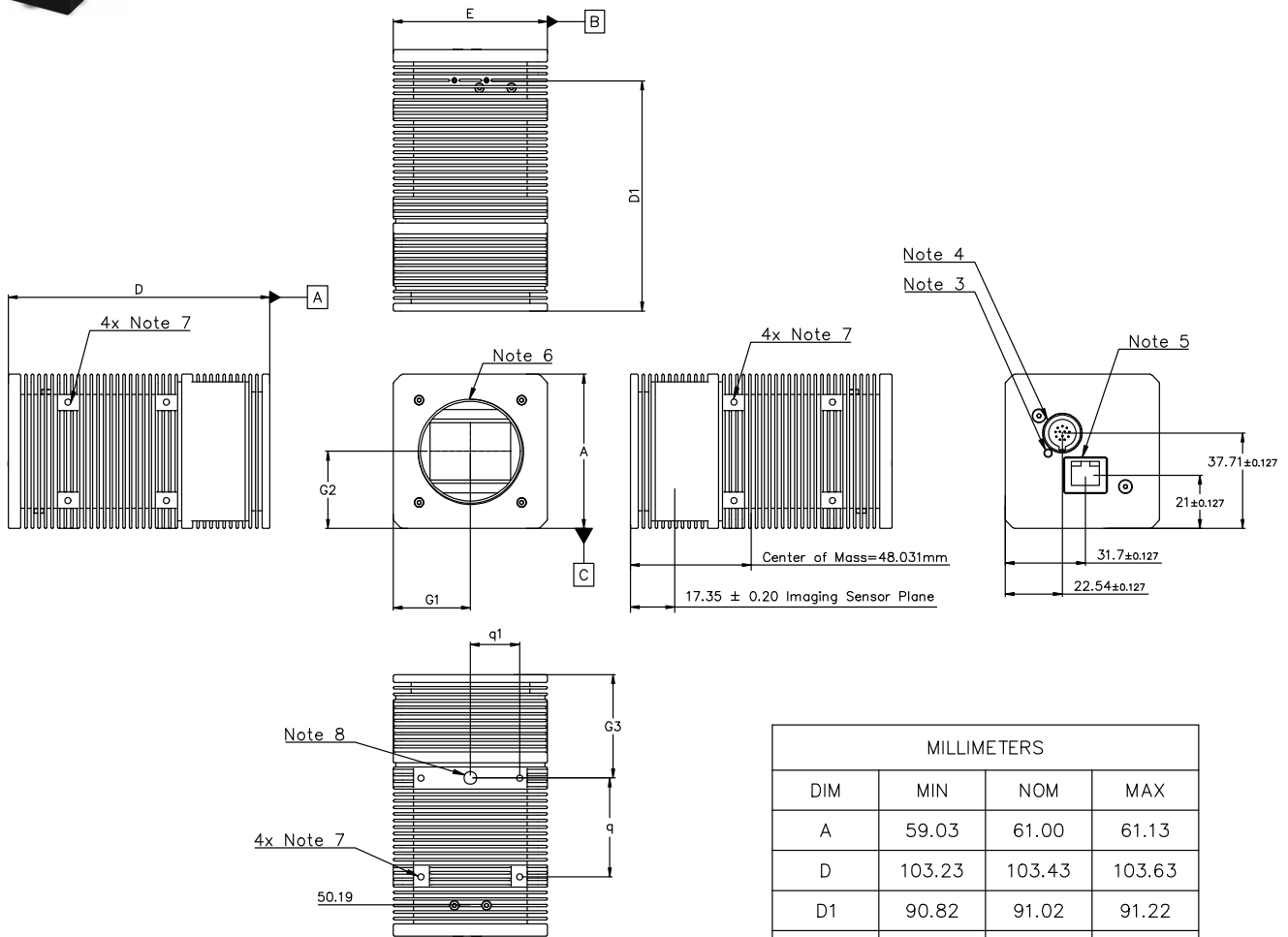

- NOTES:**
1. DIMENSIONING AND TOLERANCING PER ASME Y14.5M. 2018.
 2. CONTROLLING DIMENSION: MILLIMETER
 3. POWER INDICATOR
 4. HIROSE 12 PIN CONNECTOR
 5. GigE CONNECTOR
 6. M42 MOUNT DEPTH ∇ 9.8
 7. M3X0.5 DEPTH ∇ 3.0
 8. 1/4-20 UNC DEPTH ∇ 5.08

MILLIMETERS			
DIM	MIN	NOM	MAX
A	59.03	61.00	61.13
D	103.23	103.43	103.63
D1	90.82	91.02	91.22
E	59.03	61.00	61.13
G1	30.37	30.50	30.63
G2	30.37	30.50	30.63
G3	40.70	40.83	40.96
q	38.98	39.11	39.24
q1	19.37	19.50	19.63

DOCUMENT NUMBER:	98AON65003H	Electronic versions are uncontrolled except when accessed directly from the Document Repository. Printed versions are uncontrolled except when stamped "CONTROLLED COPY" in red.
DESCRIPTION:	CMOD 103.43x61.00x61.00	PAGE 1 OF 1

onsemi and ONSEMI are trademarks of Semiconductor Components Industries, LLC dba onsemi or its subsidiaries in the United States and/or other countries. onsemi reserves the right to make changes without further notice to any products herein. onsemi makes no warranty, representation or guarantee regarding the suitability of its products for any particular purpose, nor does onsemi assume any liability arising out of the application or use of any product or circuit, and specifically disclaims any and all liability, including without limitation special, consequential or incidental damages. onsemi does not convey any license under its patent rights nor the rights of others.