

DIP-38, 29.60x18.20x7.70, 1.00P (EP-4)
CASE 125BS
ISSUE C

DATE 08 JUN 2026

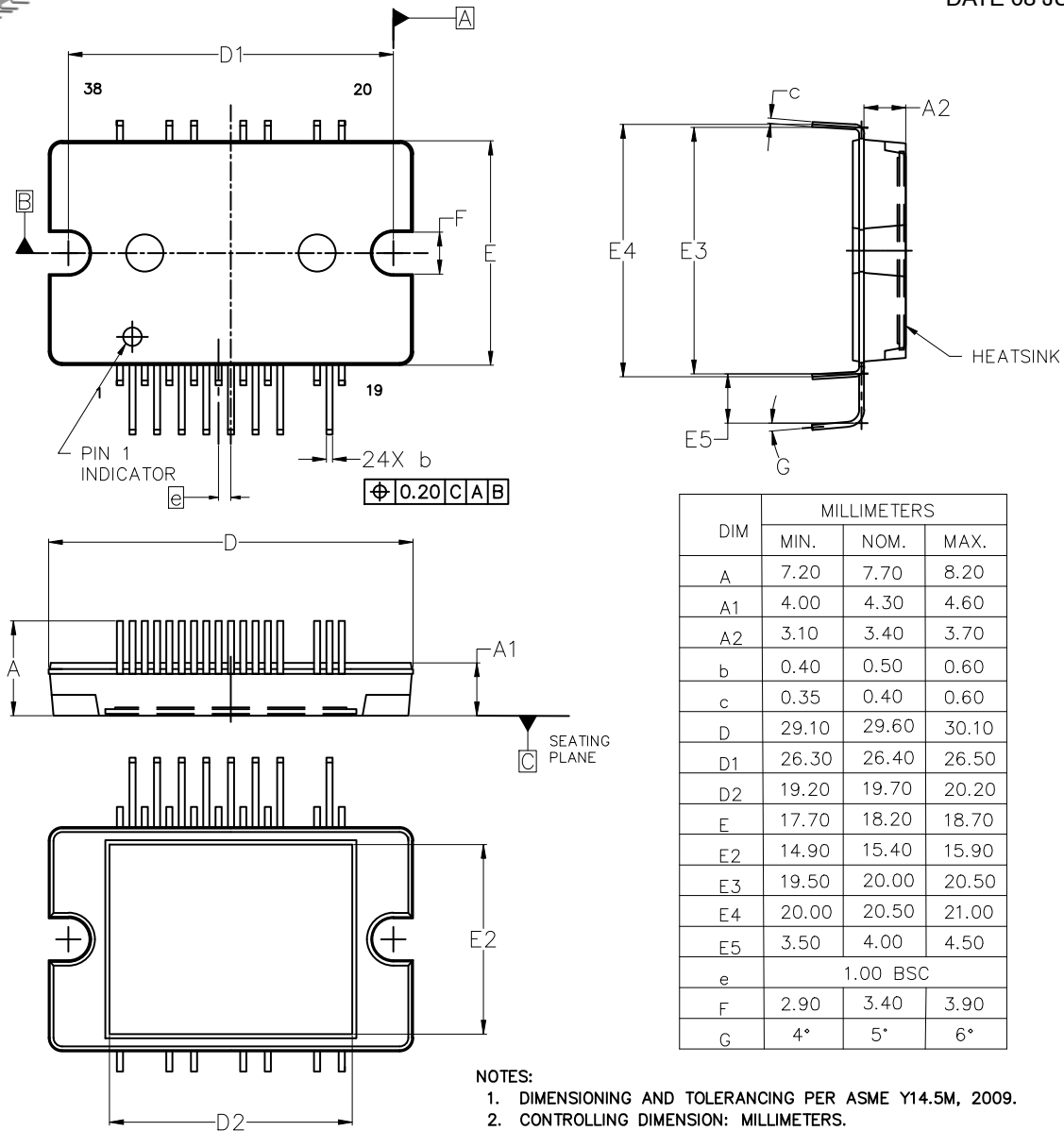

DIM	MILLIMETERS		
	MIN.	NOM.	MAX.
A	7.20	7.70	8.20
A1	4.00	4.30	4.60
A2	3.10	3.40	3.70
b	0.40	0.50	0.60
c	0.35	0.40	0.60
D	29.10	29.60	30.10
D1	26.30	26.40	26.50
D2	19.20	19.70	20.20
E	17.70	18.20	18.70
E2	14.90	15.40	15.90
E3	19.50	20.00	20.50
E4	20.00	20.50	21.00
E5	3.50	4.00	4.50
e	1.00 BSC		
F	2.90	3.40	3.90
G	4°	5°	6°

- NOTES:
1. DIMENSIONING AND TOLERANCING PER ASME Y14.5M, 2009.
 2. CONTROLLING DIMENSION: MILLIMETERS.
 3. DIMENSION b APPLIES TO THE PLATED LEAD AND IS MEASURED BETWEEN 0.10 AND 0.25 FROM THE LEAD TIP.
 4. PACKAGE IS MISSING PINS: 15, 16, 21, 23, 24, 25, 27, 29, 30, 31, 33, 35, 36, AND 37.

GENERIC MARKING DIAGRAM*

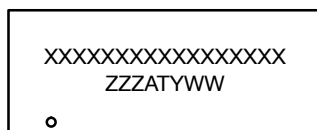

XXXX = Specific Device Code
 ZZZ = Lot ID
 AT = Assembly & Test Location
 Y = Year
 WW = Work Week

*This information is generic. Please refer to device data sheet for actual part marking. Pb-Free indicator, "G" or microdot "•", may or may not be present. Some products may not follow the Generic Marking.

DOCUMENT NUMBER:	98AON92315G	Electronic versions are uncontrolled except when accessed directly from the Document Repository. Printed versions are uncontrolled except when stamped "CONTROLLED COPY" in red.
DESCRIPTION:	DIP-38, 29.60x18.20x7.70, 1.00P (EP-4)	PAGE 1 OF 1

onsemi and ONSEMI are trademarks of Semiconductor Components Industries, LLC dba onsemi or its subsidiaries in the United States and/or other countries. onsemi reserves the right to make changes without further notice to any products herein. onsemi makes no warranty, representation or guarantee regarding the suitability of its products for any particular purpose, nor does onsemi assume any liability arising out of the application or use of any product or circuit, and specifically disclaims any and all liability, including without limitation special, consequential or incidental damages. onsemi does not convey any license under its patent rights nor the rights of others.