

Discrete Double Pulse Tester Evaluation Board User's Manual

EVBUM2897G-EVB

Discrete Double Pulse Tester Description

Double pulse tester (DPT) is designed for comparative measurement of onsemi SiC MOSFETs and IGBTs in discrete packages. User can quickly test devices in variety of packages and compare its performance. The tester is not designed to be used for characterization or datasheet data validation. Main usage of the tester is for testing of switching performance, comparison of different types of devices. Discrete DPT comes as all in system user-friendly settings.

This document serves as a user manual for the main motherboard and daughter cards.

onsemi offers 6 types of daughter cards for discrete packages:

- TO247-3L
- TO247-4L
- D2PAK-7L
- T2PAK-7L
- TOLL
- POWER88

Evaluation Board Operation

The board is designed as RoHS compliant. Design of the board was not qualified for manufacturing. No tests were made on whole operating temperature range. No lifetime tests were performed. The board must be used in lab environment only and must be operated by skilled personal trained on all safety standards. Further details of used components are in their respective datasheets.

Features

- 4 Layer FR4 PCB with 70 μm Copper Thickness
- Low Inductance PCB Layout
- Designed to Support up to 1200 V Devices
- Isolated Single Gate Drivers with 2.5 kV Insulation
- Optional of Electrolyte or Film Capacitors DC Link
- Integrated Current Measurement Transformer
- Integrated Wire Wound Air Inductor 80 μH
- DC Link Up to 1100 V

For temperature measurements and double pulse signal generating onsemi offers extension board:

Hotplate and Double Pulse Signal Generator

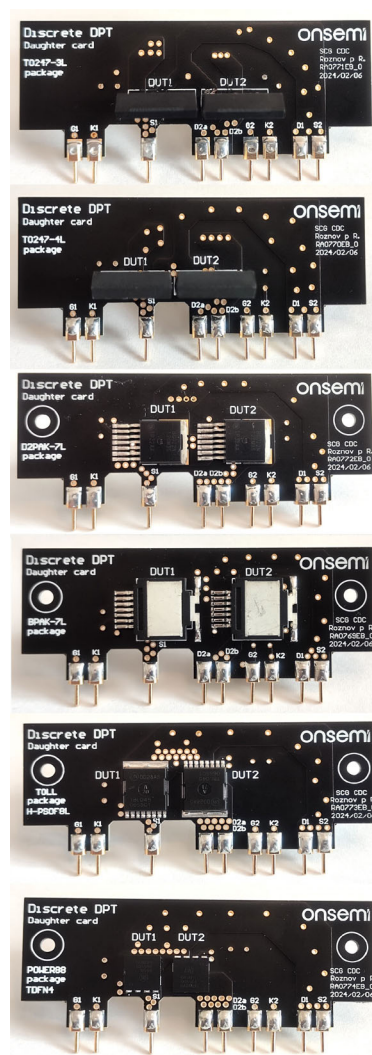
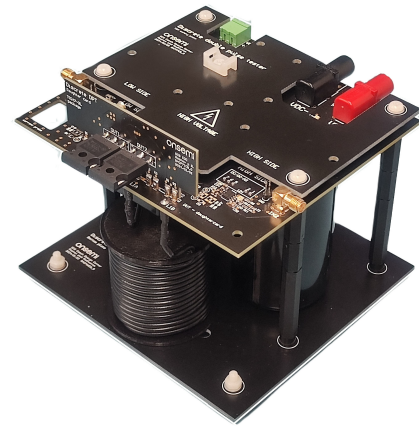

Figure 1. Discrete DPT Motherboard and Daughter Cards

APPLICATIONS INFORMATION

Motherboard PCB

Motherboard PCB contains two single channel gate drivers NCD57084. Secondary side of gate drivers is supplied by isolated 2W DC/DC Source. VDC+ and VDC- connectors are used for external High Voltage power source. Connector VCC +5 V for gate drivers supply. Input connectors IN1, IN2 for connecting a PWM signal through SMA connectors. Next part of the board is a current measurement system using a CT current transformer. Inductor is connected from the Bottom side of the PCB through connectors L1A, L1B.

Mechanical Parts, Dimensions

PCB motherboard outline dimensions are 140 mm × 130 mm, PCB thickness is 2 mm. The board outline is shown in Figure 2.

DPT includes additional PCBs:

BOTTOM plate and set – M4 Spacers, standoffs and screws as base plate for motherboard and air coil inductor. TOP safety plate – HV touch protection and mechanical holder for V_{GS} and V_{DS} oscilloscope probes.

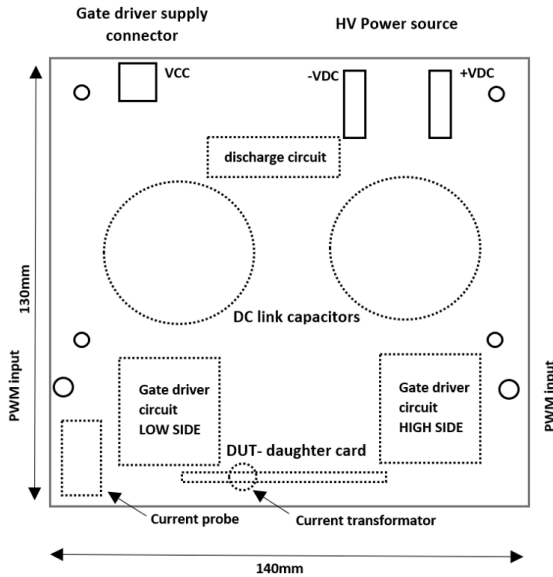

Figure 2. Simplify PCB Block Diagram

Gate Drivers – Fault Outputs

onsemi NCD57084 gate driver has two protection functions, READY function “RDY” and DESAT. The RDY fault is triggered by UVLO at the secondary side of the driver. RDY is active LOW. RDY fault is cleared with rising edge of input PWM signal and secondary UVLO condition is no longer present. At the first power up of the evaluation board the drivers will be in fault condition. Fault signal will be cleared with first PWM pulse. The second protection

function of the gate driver desaturation protection “DESAT” is not used on this board.

Input PWM Signals

PWM inputs signals can be supplied externally via SMA connectors IN1 and IN2 by Signal Generator, IN1 – Low side D.U.T. IN2– High side D.U.T.

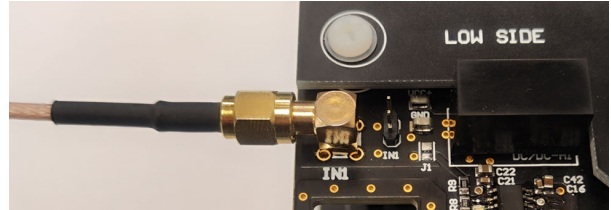

Figure 3. PWM Inputs and SMA Signal Cable

Input signals can be generated by extension board: Hotplate and double pulse signal generator.

Input voltage level of PWM signals:

V_{IL} Low Input Voltage 0 – 1.5 V

V_{IH} High Input Voltage 3.5 – 5 V

Solder jumpers J1, J2 are default set to OFF. In case ON (tin bridge) input PWM signal is grounded (LOW Voltage on gate driver input.

For Signal generator connection a 50 Ω SMA cable: AMPHENOL RF 135101-01-24.00 is recommended.

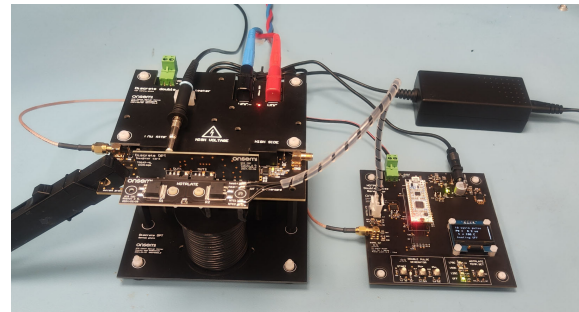

Figure 4. Measurement setup – Discrete DPT + Extension Board Hotplate and Double Pulse Signal Generator

Electrical Rating

The board is rated to DC voltage input 840 VDC. Maximum voltage in the DC link is 900 V. There is no protection for exceeding maximum DC link voltage or for reverse polarity. No inrush current limitation is present on the board.

Do not exceed the maximum voltage in the DCLink DC_{max} = 900 V.



Figure 5. Mother Board TOP and BOTTOM View

DC-DC Converter

DC-DC converter ensures galvanic insulated supply of gate driver secondary side.

Motherboard is populated with isolated DC/DC sources CUI-VQA3S-S5-D18-S providing $V_{out} = -3.5\text{ V}$, $V_{out+} = 18\text{ V}$. DC/DC converters can be easily replaced by inserting into the socket pins on the motherboard as shown on the Figure 6.

For using different gate driver voltage, user can swap the DC/DC converters it is possible populate these DC/DC converters:

Table 1. DC/DC CONVERTERS

Type	Voltage Output
CUI - VQA3S-S5-D15-S	-5 V / 15 V
CUI- VQA3S-S5-D20-S	-4 V / 20 V

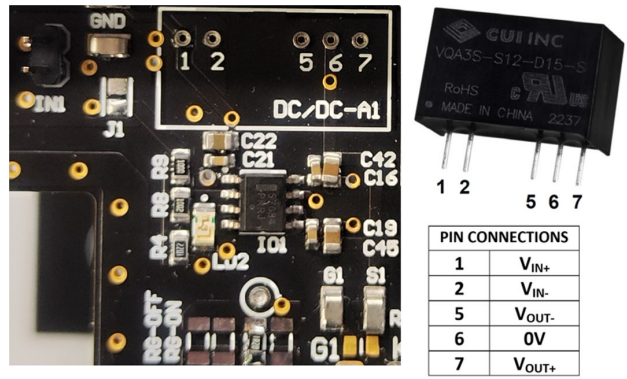

Figure 6. DC-DC Gate Driver Converter

Gate Resistance – R_G

The choice of optimal value gate resistor is compromise between switching losses and VDS overshoot.

low R_G value – high switching speed, low losses, higher VDS overshoot

high R_G value – low switching speed, higher losses, lower VDS overshoot

(Board comes assembled with $R_{GON} = 3R9$, R_{GOFF} – not populated)

Resistor type is pulsed type resistor in SMD 1206 package. Eval. board allows assembled two pieces in parallel for precise R_G tuning. Optionally Trough-hole resistor, e.g. type R0204 can be used for quick solder-less tuning Figure 7 .

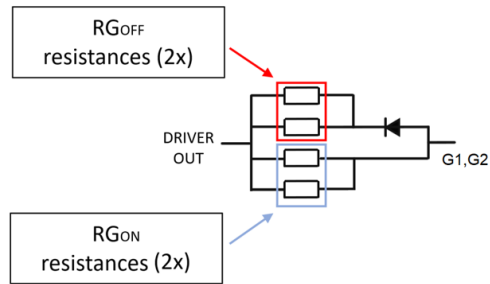

Figure 7. Gate Resistance Schematic and PCB

DC Link

DC link serves as energy storage and provides sufficient energy transfer to inductor switching loop. It is assembled with electrolytic capacitors C53, C54 – 550µF 550 V. (Optional film capacitors, e.g. type C4AQPEW5450M3BJ 45 µF / 1200 V can be used)

High frequency snubber capacitors C4, C1, C2, C5 are used to provide low inductance switching loop and helps to reduce noise propagating to the DC link due to switching of the devices.

DC link schematic contain R17–R22, R25–R30 balance resistors necessary for series connection of electrolytic capacitors ensuring uniform voltage.

CAUTION: Do not touch the motherboard when LD3 is ON. High voltage present in DC link. Wait a few minutes after disconnecting the Power source.



Figure 8. High Voltage Present

Air Core Inductor

The inductor used for double pulse test is dimensioned to allow enough pulse resolution and to achieve pulsed current $I = 150$ A. Air inductor is wound on cylinder spool with diameter 25 mm × 48 mm, Inductance $L \approx 80 \mu\text{H}$, Inductor resistance $R \approx 300 \text{ m}\Omega$.



Figure 9. Air Core Inductor

Current Sensing

Current is measured using (CT) toroidal current transformer. This method provides accurate measurement of current and galvanic insulation. I_D current passes through center of the toroid (pin S1 on the daughter card). Secondary side of CT consist of 10 turns winding which is connected on the mother board. PCB trace forms a closed loop where the the advantage of this solution is the low added loop of the DC power path.

Current can be measured using oscilloscope current probe, e.g. type TCP0020. Attenuation CT is 10. This corresponds $I_D = I_{CT} \times 10$.

Second option of current measurement is using Rogowski coil probe. Figure 11.

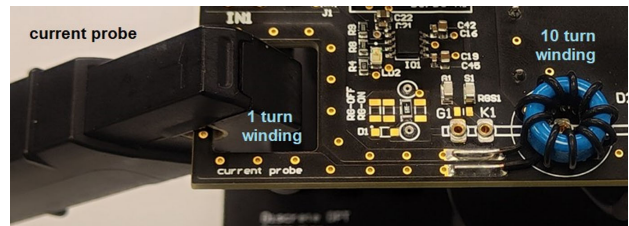

Figure 10. Current Transformer

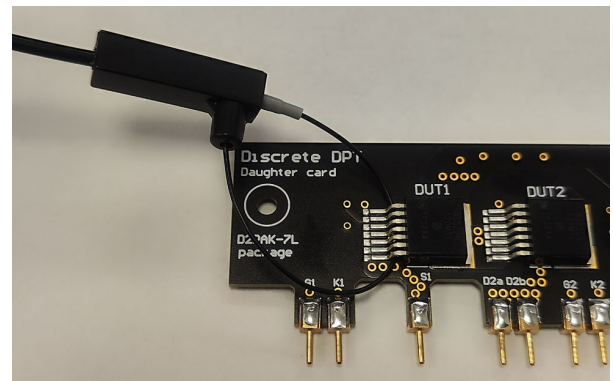
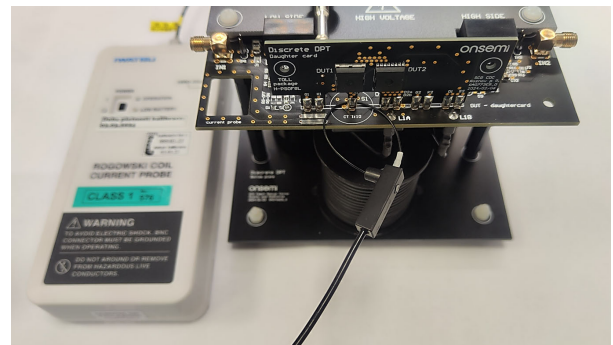

Figure 11. Application Rogowski Current Probe

Daughter Cards

Daughter cards allow DPT measurements for various onsemi packages. TO247-3L, TO247-4L, D2PAK-7L, T2PAK-7L, TOLL, POWER88. There is a unique daughtercard PCB for each of the package containing DUT, passives, and test points so user can plug in and conduct measurements.

Table 2. OPN DAUGHTER CARDS PCBs

Daughter Card – Package	onsemi OPN
TO247-3L	RA0771EB
TO247-4L	RA0770EB
D2PAK-7L	RA0772EB
T2PAK-7L	RA0769EB
TOLL	RA0773EB
POWER88	RA0774EB

PCB dimensions are 80 mm × 22 mm, thickness of the PCB is 1.6 mm. Daughter cards for SMD packages include mounting holes for measurements in the temperature room using a hot plate.

Daughter cards contain two transistors DUT1 – LOW side, DUT2 – HIGH side connected as half bridge schematic. Figure 12. Drain current is measured on the LOW side. Inductor is connected between D–S on High side. The board allows to measure V_{GS} and V_{DS} voltage using a test point on the PCB bottom side.

Gate capacitors C1, C2 can be used in case of tuning gate oscillations on waveforms. Capacitors slows the di/dt during turn-on and reduces the impact of the Miller capacitance.

Snubber capacitor C3 can be populated if the measurement does not require current measurement by CT and stray inductance needs to be reduced further.

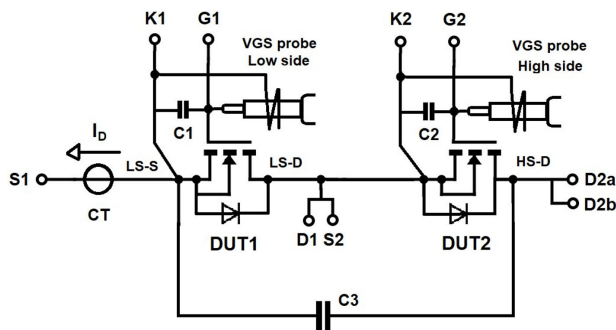

Figure 12. Daughter Cards Schematic

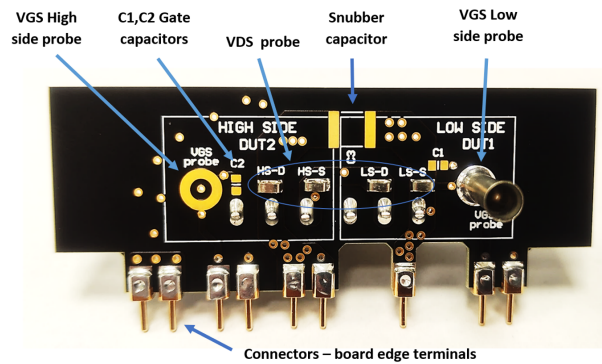

Figure 13. Daughter Cards BOT Side

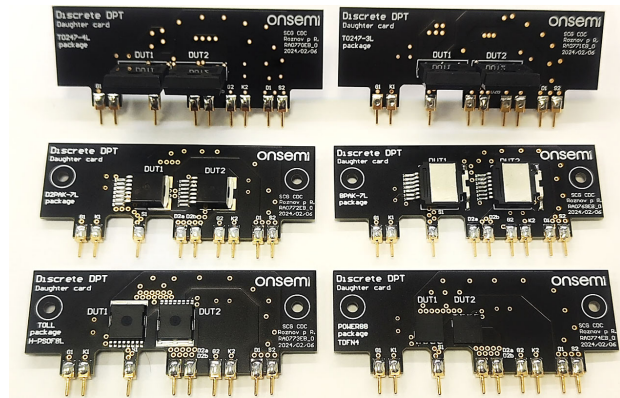

Figure 14. Daughter Cards Various Package

Daughter Card System Installation

Electrical and mechanical connection with the motherboard is realized by soldered terminals located board edge daughter cards and sockets in the motherboard as shown Figure 15. During daughter card mounting it is necessary to press evenly on both sides of the PCB. Pin S1 passes through the center of CT.

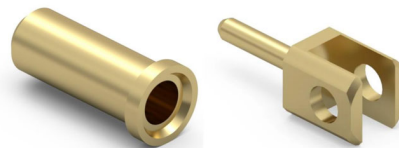

Figure 15. Mill Max Socket and Terminal Pin

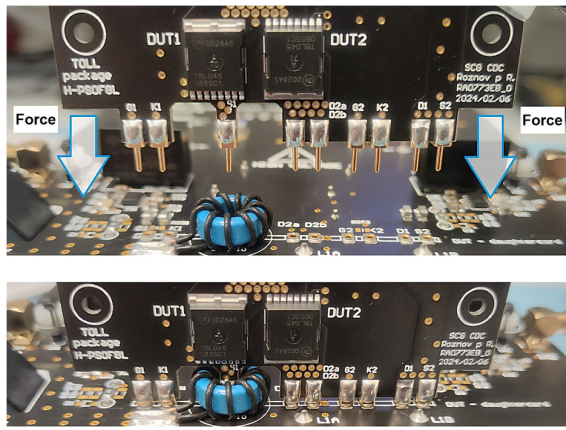

Figure 16. Motherboard and Daughter Card Assembly

Measure Points

Daughter cards allow to measure the voltage V_{DS} and V_{GS} close to the DUT MOSFETs.

For V_{DS} measurement test points:

LS-D – Low side DUT1 Drain

LS-S – Low side DUT1 Source

HS-D – High side DUT2 Drain

HS-S – High side DUT2 Source

V_{GS} measurement with a passive probe is optional. Probes can be connected using spring (part of the oscilloscope accessory) or wire ferrule. Figure 17.

For Lecroy passive probe is suitable type: diam. 3×12 mm

For Tektronix: diam: 4.2×15 mm

CAUTION: High side V_{GS} measurement must be performed only with differential probe or galvanically insulated (floating) oscilloscope setup.

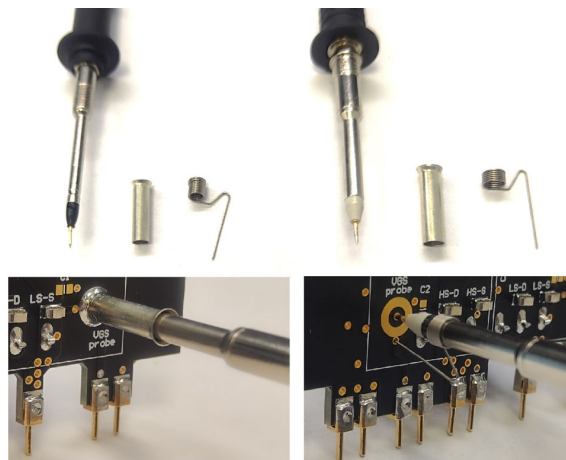

Figure 17. Compatible with Lecroy, Tektronix V_{GS} Passive Probe

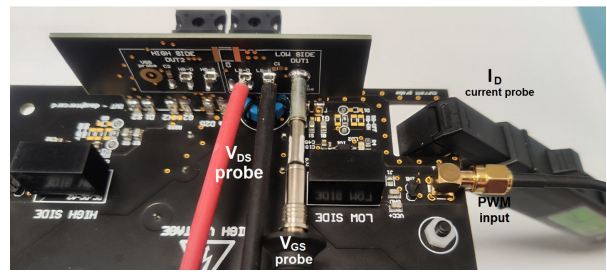
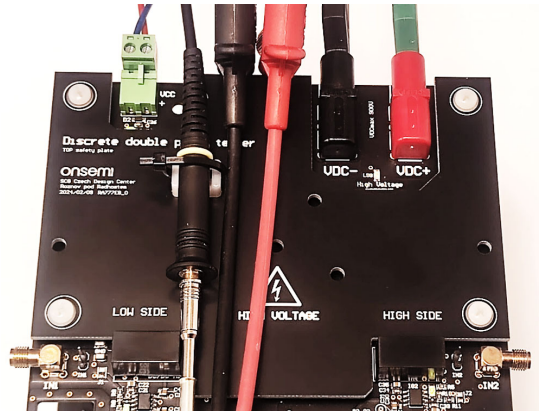

Figure 18. V_{GS} , V_{DS} , I_D Probes Connection



Double Pulse Test

Double pulse test allows for waveform capture of V_{GS} , V_{DS} and current I_D and compare different types of devices.

From the measured waveforms it is possible to extract switching parameters:

Losses – (E_{ON} , E_{OFF} , E_{RR}), Speed – (di/dt , dV/dt)

Switching times – (T_d , T_r , T_f), Overshoot – (V_{DS} , I_D)

DPT was performed with **onsemi** MOSFETs for 1200 V and 650 V small packages.

Equipment for DPT

- Discrete DPT motherboard + daughter card
- Digital 4ch oscilloscope with sufficient bandwidth
- Passive low side V_{GS} probe (Tektronix, Lecroy compatible)
- Differential V_{DS} probe
- Current probe I_D e.g TCP0020 (range 20 A_{RMS})
- POWER supply 5 V 1 A
- High Voltage POWER supply ~ 800 V
- Singla generator with burst function
- SMA – BNC cable
- Optional: **onsemi** extension board – Double pulse generator and hotplate

Measurement Process

Select the daughtercard and install it into the motherboard. Connect V_{GS} , V_{DS} , I_D probe and input BNC cable according Figures 18, 20. Set the signal generator on the manual trigger and pulse signal parameters e.g. ($V_{PWM} = 5\text{ V}$, 10 pulse, 30 kHz/ Pulse width = $0.5\ \mu\text{s}$). Set up the oscilloscope and trigger on the V_{GS} channel. Set channel deskew according to the used voltage and current probes. Connect Power supply $V_{CC} +5\text{ V}$. Current consumption from the 5 V source should be around 100 mA. Trigger the generator and gradually increase Voltage on HV Power source up to the maximum test voltage. The shape of the waveforms should be similar to Figures 21–25.

NOTE: V_{DS} overshoot must not exceed V_{DSS} of the MOSFET. Current I_D can be set by Pulse width on the signal generator. Switching speed can be adjusted by the R_G resistance.

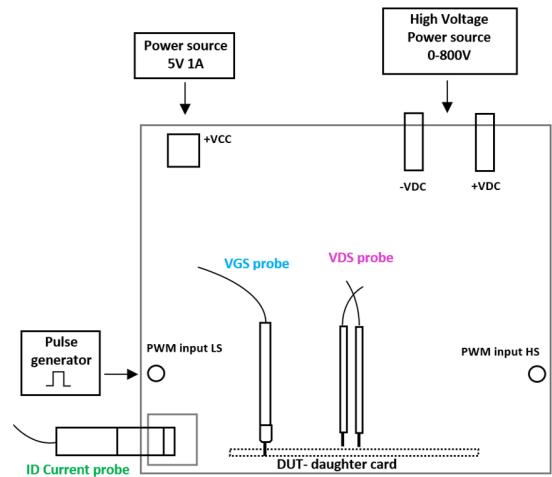

Figure 20. DPT – Motherboard Connection

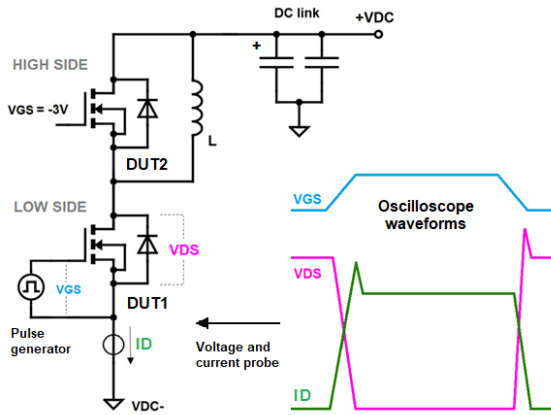

Figure 19. DPT Operation

DPT Measure Results

Table 3. TESTED onsemi DEVICES

Daughtercard Package	onsemi Discrete Product	Description	Waveforms
TO247-3L	NTHL022N120M3S	22 mR 1200 V M3S	Figure 21
TO247-4L	NTH4L022N120M3S	22 mR 1200 V M3S	Figure 22
D2PAK	NTBG022N120M3S	22 mR 1200 V M3S	Figure 23
TOLL	NTBL045N065SC1	33 mR 650 V M2	Figure 24
POWER88	NTMT045N065SC1	33 mR 650 V M2	Figure 25

EVBUM2897G-EVB

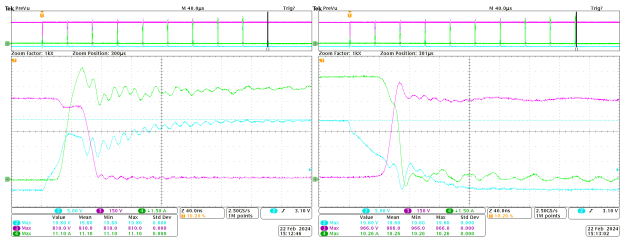

DPT conditions: $V_{DC} = 800\text{ V}$, $I_D = 100\text{ A}$, $R_G = 6R8$, $T_J = 25^\circ\text{C}$, $V_{GS} = 18/-3\text{ V}$, $PW = 1.2\text{ }\mu\text{s}$

Figure 21. TO247-3L – NTHL022N120M3S

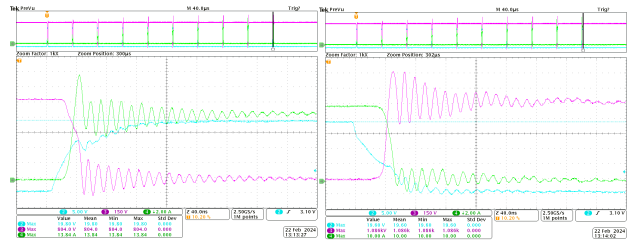

DPT conditions: $V_{DC} = 800\text{ V}$, $I_D = 100\text{ A}$, $R_G = 3R9$, $T_J = 25^\circ\text{C}$, $V_{GS} = 18/-3\text{ V}$, $PW = 1.4\text{ }\mu\text{s}$

Figure 22. TO247-4L – NTH4L022N120M3S

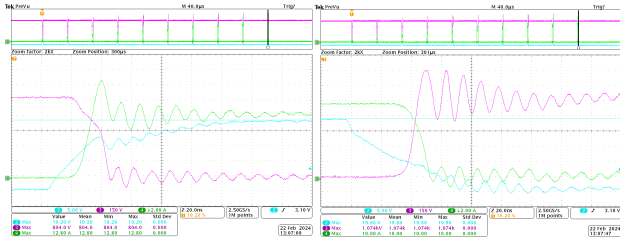

DPT conditions: $V_{DC} = 800\text{ V}$, $I_D = 100\text{ A}$, $R_G = 3R9$, $T_J = 25^\circ\text{C}$, $V_{GS} = 18/-3\text{ V}$, $PW = 1.4\text{ }\mu\text{s}$

Figure 23. D2PAK-7L – NTBGO22N120M3S

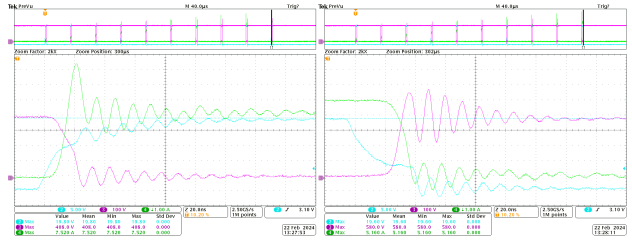

DPT conditions: $V_{DC} = 400\text{ V}$, $I_D = 50\text{ A}$, $R_G = 3R9$, $T_J = 25^\circ\text{C}$, $V_{GS} = 18/-3\text{ V}$, $PW = 1.6\text{ }\mu\text{s}$

Figure 24. TOLL – NTBL045N065SC1

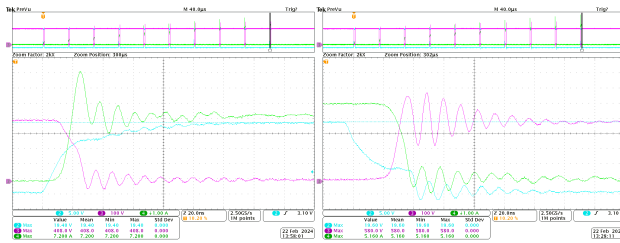

DPT conditions: $V_{DC} = 400\text{ V}$, $I_D = 50\text{ A}$, $R_G = 3R9$, $T_J = 25^\circ\text{C}$, $V_{GS} = 18/-3\text{ V}$, $PW = 1.6\text{ }\mu\text{s}$

Figure 25. POWER88 – NTMT045N065SC1

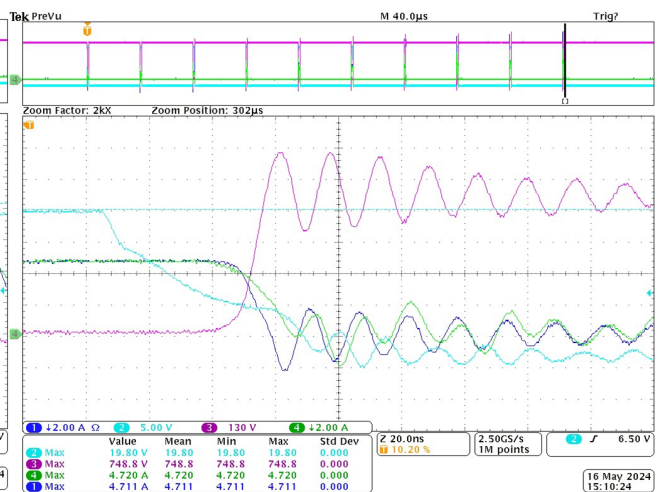
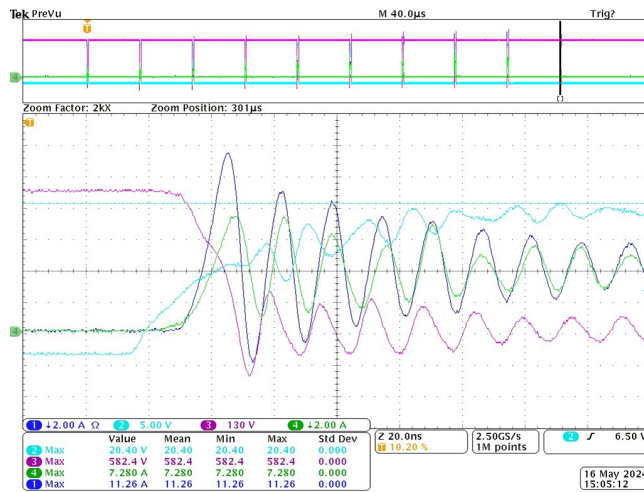

onsemi discrete device: NTHL022N120M3S – TO247-4L
 DPT conditions: $V_{DC} = 600\text{ V}$, $I_D = 50\text{ A}$, $R_G = 3R9$, $T_J = 25^\circ\text{C}$, $V_{GS} = 18/-3\text{ V}$, $PW = 1\text{ }\mu\text{s}$
 Waveforms: red- V_{DS} , light blue- V_{GS} , dark blue- I_D shunt, green- I_D CT

Figure 26. Comparison of the method of current measurement current transformer CT vs. CVR shunt (T&M-SSDN-015)

EVBUM2897G-EVB

Table 4. Comparison di/dt, switching losses E_{ON} , E_{OFF}

	di/dt turn ON	E_{ON}	E_{OFF}	$E_{ON} + E_{OFF}$
Shunt	6580 A/ μ s	431 μ J	141 μ J	572 μ J
CT	4380 A/ μ s	224 μ J	296 μ J	520 μ J

CVR shut method shows a faster di/dt, but $E_{ON} + E_{OFF}$ losses are comparable.

Schematic – Motherboard

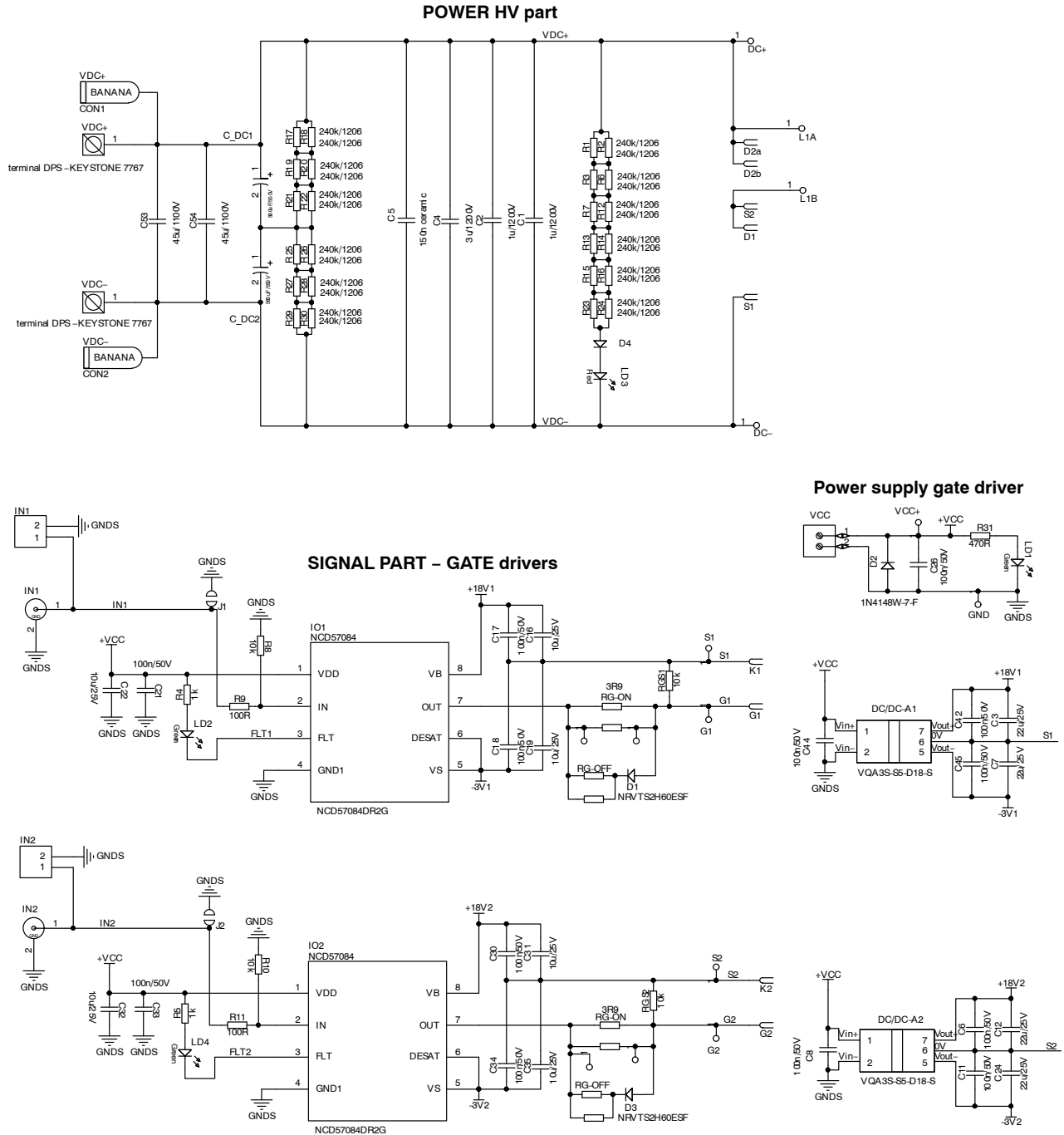

Figure 27. Schematic

EVBUM2897G-EVB

REVISION HISTORY

Revision	Description of Changes	Date
3	BPAK7 changed to T2PAK-7L, Figure 24 BPAK-7L – NTTC040N120M3S removed.	2/13/2026

This document has undergone updates prior to the inclusion of this revision history table. The changes tracked here only reflect updates made on the noted approval dates.

onsemi, **Onsemi**, and other names, marks, and brands are registered and/or common law trademarks of Semiconductor Components Industries, LLC dba "**onsemi**" or its affiliates and/or subsidiaries in the United States and/or other countries. **onsemi** owns the rights to a number of patents, trademarks, copyrights, trade secrets, and other intellectual property. A listing of **onsemi**'s product/patent coverage may be accessed at www.onsemi.com/site/pdf/Patent-Marking.pdf. **onsemi** is an Equal Opportunity/Affirmative Action Employer. This literature is subject to all applicable copyright laws and is not for resale in any manner.

The evaluation board/kit (research and development board/kit) (hereinafter the "board") is not a finished product and is not available for sale to consumers. The board is only intended for research, development, demonstration and evaluation purposes and will only be used in laboratory/development areas by persons with an engineering/technical training and familiar with the risks associated with handling electrical/mechanical components, systems and subsystems. This person assumes full responsibility/liability for proper and safe handling. Any other use, resale or redistribution for any other purpose is strictly prohibited.

THE BOARD IS PROVIDED BY ONSEMI TO YOU "AS IS" AND WITHOUT ANY REPRESENTATIONS OR WARRANTIES WHATSOEVER. WITHOUT LIMITING THE FOREGOING, ONSEMI (AND ITS LICENSORS/SUPPLIERS) HEREBY DISCLAIMS ANY AND ALL REPRESENTATIONS AND WARRANTIES IN RELATION TO THE BOARD, ANY MODIFICATIONS, OR THIS AGREEMENT, WHETHER EXPRESS, IMPLIED, STATUTORY OR OTHERWISE, INCLUDING WITHOUT LIMITATION ANY AND ALL REPRESENTATIONS AND WARRANTIES OF MERCHANTABILITY, FITNESS FOR A PARTICULAR PURPOSE, TITLE, NON-INFRINGEMENT, AND THOSE ARISING FROM A COURSE OF DEALING, TRADE USAGE, TRADE CUSTOM OR TRADE PRACTICE.

onsemi reserves the right to make changes without further notice to any board.

You are responsible for determining whether the board will be suitable for your intended use or application or will achieve your intended results. Prior to using or distributing any systems that have been evaluated, designed or tested using the board, you agree to test and validate your design to confirm the functionality for your application. Any technical, applications or design information or advice, quality characterization, reliability data or other services provided by **onsemi** shall not constitute any representation or warranty by **onsemi**, and no additional obligations or liabilities shall arise from **onsemi** having provided such information or services.

onsemi products including the boards are not designed, intended, or authorized for use in life support systems, or any FDA Class 3 medical devices or medical devices with a similar or equivalent classification in a foreign jurisdiction, or any devices intended for implantation in the human body. You agree to indemnify, defend and hold harmless **onsemi**, its directors, officers, employees, representatives, agents, subsidiaries, affiliates, distributors, and assigns, against any and all liabilities, losses, costs, damages, judgments, and expenses, arising out of any claim, demand, investigation, lawsuit, regulatory action or cause of action arising out of or associated with any unauthorized use, even if such claim alleges that **onsemi** was negligent regarding the design or manufacture of any products and/or the board.

This evaluation board/kit does not fall within the scope of the European Union directives regarding electromagnetic compatibility, restricted substances (RoHS), recycling (WEEE), FCC, CE or UL, and may not meet the technical requirements of these or other related directives.

FCC WARNING – This evaluation board/kit is intended for use for engineering development, demonstration, or evaluation purposes only and is not considered by **onsemi** to be a finished end product fit for general consumer use. It may generate, use, or radiate radio frequency energy and has not been tested for compliance with the limits of computing devices pursuant to part 15 of FCC rules, which are designed to provide reasonable protection against radio frequency interference. Operation of this equipment may cause interference with radio communications, in which case the user shall be responsible, at its expense, to take whatever measures may be required to correct this interference.

onsemi does not convey any license under its patent rights nor the rights of others.

LIMITATIONS OF LIABILITY: **onsemi** shall not be liable for any special, consequential, incidental, indirect or punitive damages, including, but not limited to the costs of requalification, delay, loss of profits or goodwill, arising out of or in connection with the board, even if **onsemi** is advised of the possibility of such damages. In no event shall **onsemi**'s aggregate liability from any obligation arising out of or in connection with the board, under any theory of liability, exceed the purchase price paid for the board, if any.

The board is provided to you subject to the license and other terms per **onsemi**'s standard terms and conditions of sale. For more information and documentation, please visit www.onsemi.com.

ADDITIONAL INFORMATION

TECHNICAL PUBLICATIONS:

Technical Library: www.onsemi.com/design/resources/technical-documentation
onsemi Website: www.onsemi.com

ONLINE SUPPORT: www.onsemi.com/support

For additional information, please contact your local Sales Representative at www.onsemi.com/support/sales