

150 W Lighting Solution with NCL2801, NCL30159, NCL38046 Inside

EVBUM2896/D

SPECIFICATIONS

onsemi's Device	Application	Input Voltage	Output Power	Topology	I/O Isolation
NCL2801 NCL30159 NCL38046	Lighting	90 to 264 Vac	150 W	BOOST PFC, LLC	Isolated

No.	Description	Symbol	Min	Type	Max	Unit	Test Conditions
1	Input Voltage Range	Vin(min/max)	90	115/230	264	Vac	
2	Input Current	Irms			2	A	Full load
3	Rated Input Frequency	f _{in}	50		60	Hz	Isolated
4	Input Frequency Range	F _{in} (min/max)	47		63	Hz	
5	Rated Output Power	P _{out}		150		W	
6	Efficiency At Full Load	η		>94		%	Tested at board end, 230 Vac
				>92			Tested at board end, 115 Vac
7	Output Voltage and Current	V _{out} /I _{out}		50 V / 3 A		V/A	90 Vac–264 Vac
8	No Load Power	P _{standby}			<0.3	W	

SPECIFICATIONS AND FEATURES

- High Efficiency and Low Standby Power
- An Easily Setting SKIP Mode
- Protections
 - ◆ Over Voltage Protection
 - ◆ Over Current Protection
 - ◆ Constant Power Protection by NCL30159 and NCL38046
- High PF and Low THD

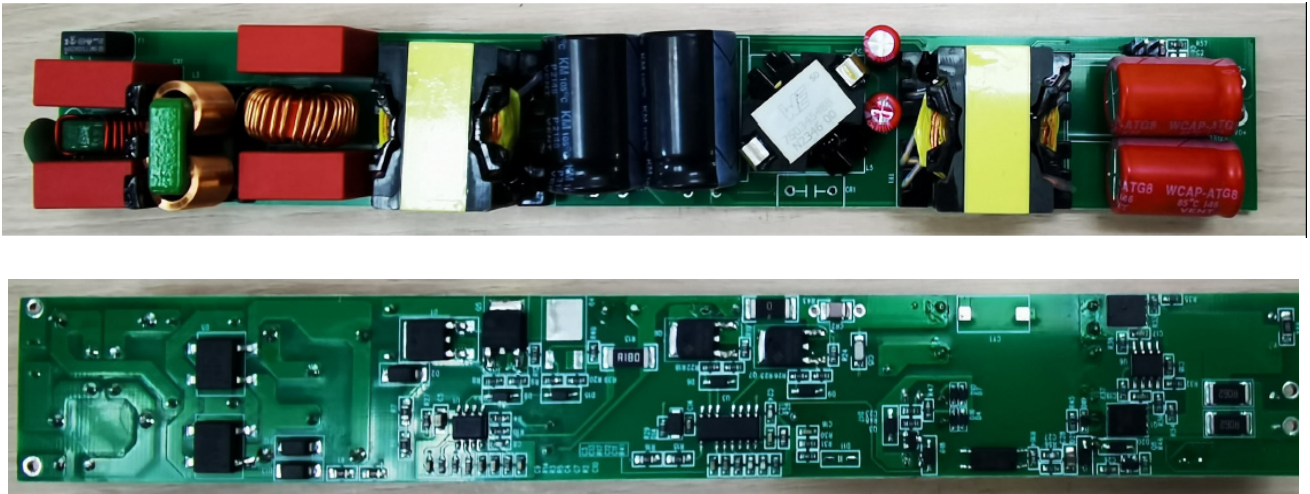

Figure 1. Demo Board Pictures

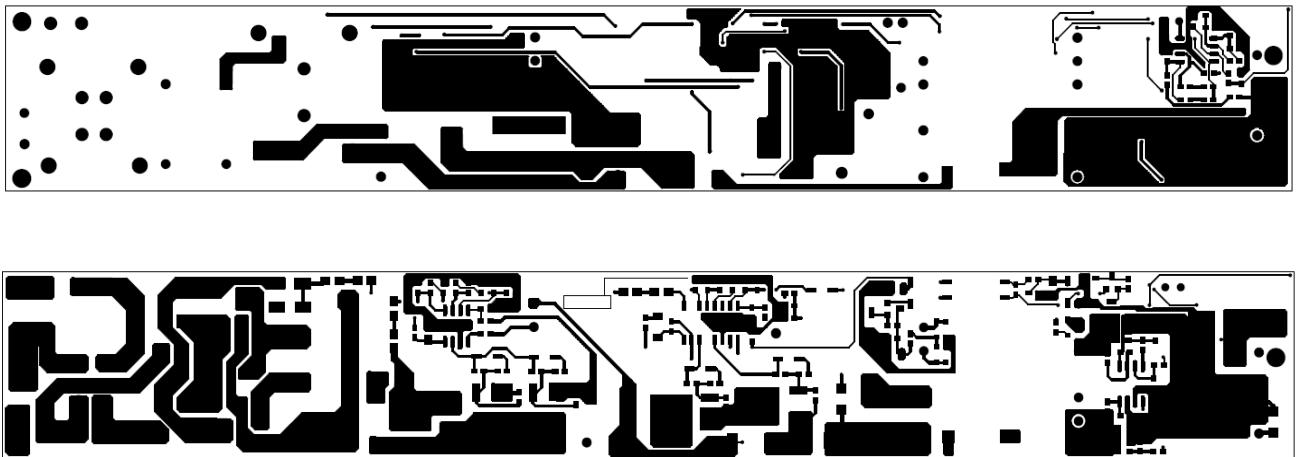

Figure 2. PCB Design

EVBUM2896/D

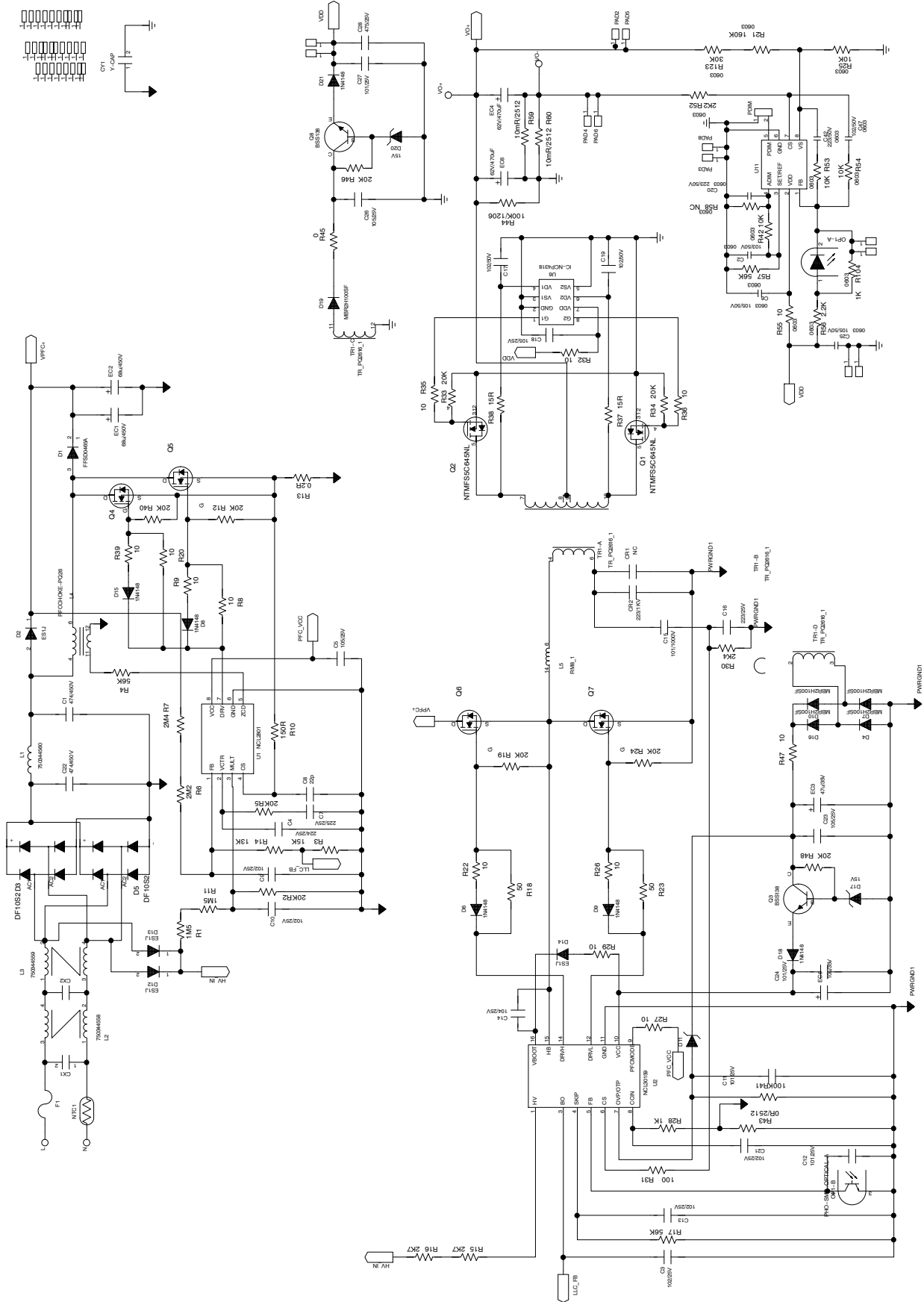

Figure 3. Application Schematic

CIRCUIT DESCRIPTION

This design used **onsemi**'s PFC controller NCL2801CDA, LLC controller NCL30159 and CC/CV mode feedback loop controller NCL38046. Thanks to **onsemi**'s current mode PFC controller NCL2801, the reference design PFC part easy to maintain a High PF value and low THD even in very light load condition.

The NCL30159 is a high performance current mode controller for half bridge resonant converters, which with an easily setting SKIP mode. This controller implements 720 V gate drivers, simplifying layout and reducing external component count.

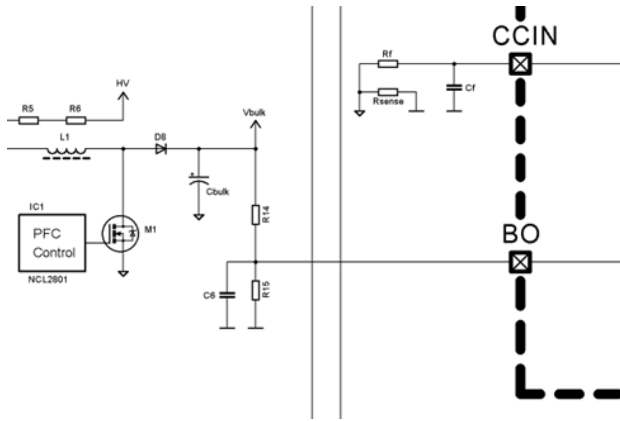

Figure 4. NCL30159 Maximum Power Setting

The NCL30159 implements maximum power limit feature. This simple system ignores the LLC stage efficiency shift at different operating points at high power level, that's why the input bulk voltage and input average current flowing into LLC stage are sensed. It's sometimes called as quasi constant power feature.

The maximum power limit can be calculated easily by Eq.1:

$$P_{\text{limit}} = \frac{R_{14} + R_{15}}{R_{15}} - \frac{V_{\text{osc_max}}}{R_{\text{sense}}} \cdot V_{\text{ref}} \quad (\text{eq. 1})$$

($V_{\text{osc_max}}$ is 3.325, V_{ref} is selectable via different IC version in range 0.500 V to 1.700 V).

As the same LLC controller in ONSEMI family, compare with NCP1399 and NCP13992, NCL30159 have a big improvement at the OCP performance which triggered by CS pin after adding the OCPRC circuit inside.

(CH2 – CS_stop_cmp_inv, CH3 – internal FB with RC, CH4 – Iprimary)

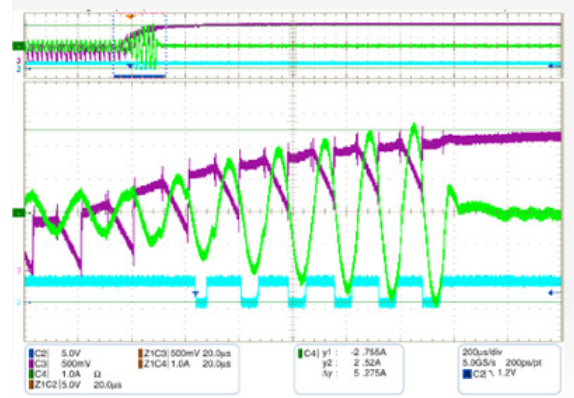

Without OCPRC

Figure 5. Resonant Choke Current when SS without OCPRC

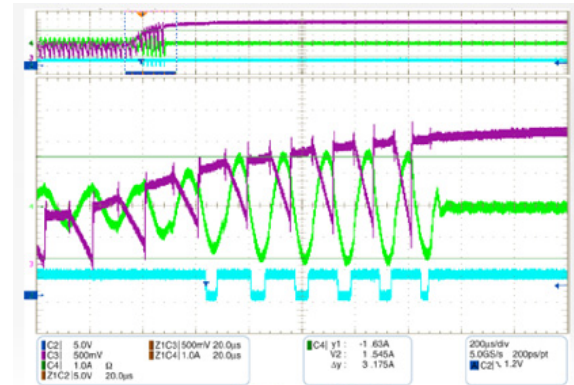

With OCPRC

Figure 6. Resonant Choke Current when SS with OCPRC

Ramp compensation gain adjusted base on over-current event, this help to get a significantly reduced primary and secondary currents under stress conditions.

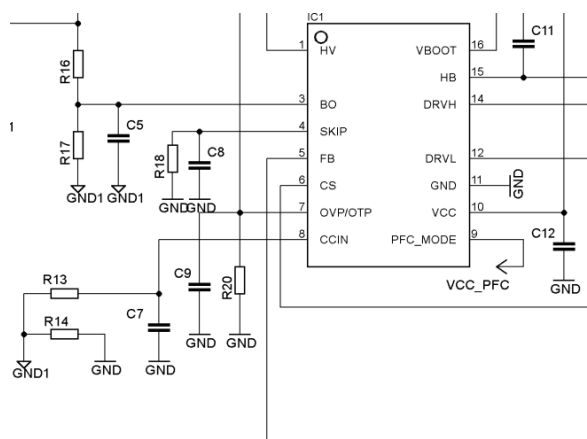

Figure 7. SKIP MODE Setting

NCL30159 implements a simple SKIP MODE setting. The SKIP_OUT level is fixed by IC IPT version (SKIP_OUT level is selectable via different IC IPT version), and there is a constant current source inside SKIP pin which is 50uA, so you can set R18 to set the SKIP_IN level.

$$SKIP_IN\ LEVEL = 50\ \mu A * R18 \quad (eq. 2)$$

SKIP_IN level should be lower than SKIP_OUT level which selected by IC IPT version.

The NCL38046 is a high performance Constant Current and Constant Voltage amplifier with low input offset voltage. It can enable to extend system dimming range under 1%. Also can support programmable constant power regulation to protect LED load and to provide wide output operating range.

NCL38046 have PA and AA version, when analog voltage signal at ADIM is used for the maximum output current setting and PWM duty signal at PDIM is used for dimming, PA version should be used. $V_{CS(REF)}$ is determined by (Eq. 3) which corresponds to Figure 8.

$$V_{CS(REF)} [V] = V_{CS(REF-MAX)} [V] \times adim [\%] \times pdim_{MOD} [\%] \quad (eq. 3)$$

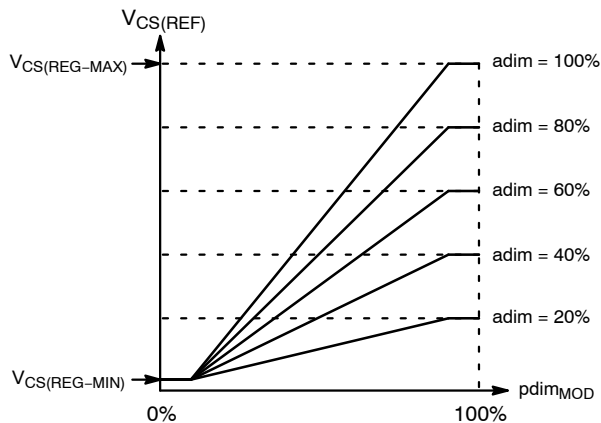

Figure 8. Dimming Curve in PA Version

When adim is used for dimming and pdim is to set the maximum output current, AA version should be used. $V_{CS(REF)}$ is set by (Eq. 4) corresponding to Figure 9.

$$V_{CS(REF)} [V] = V_{CS(REF-MAX)} [V] \times pdim [\%] \times adim_{MOD} [\%] \quad (eq. 4)$$

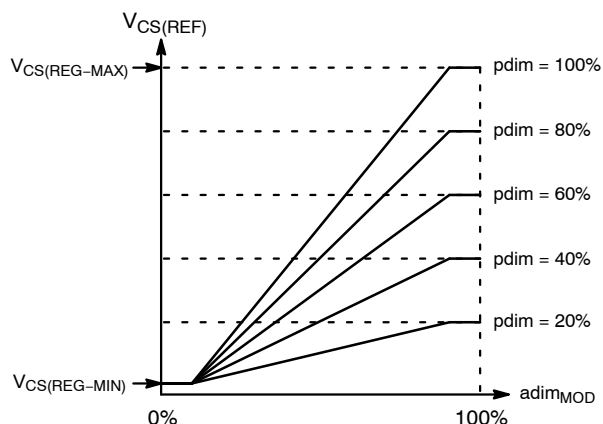

Figure 9. Dimming Curve in AA Version

$V_{CS(REF)}$ dimming voltage range is limited by $V_{CS(REF-MAX)}$ and $V_{CS(REF-MIN)}$.

Vo / Io Sensing

Figure 10 shows how to set the CC and CV feedback loop.

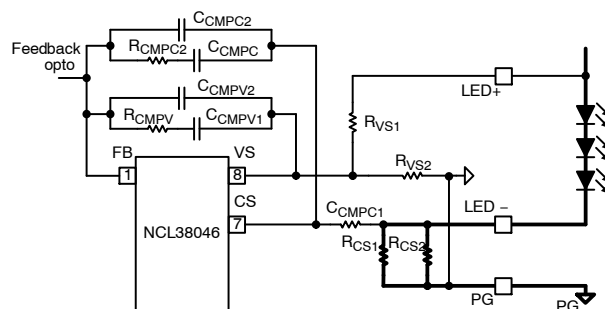

Figure 10. NCL38046 CC and CV Loop Setting

The I_{o_max} can be set by :

$$RCS = 100\ mV / I_{o_max} \quad (eq. 5)$$

Which $RCS (= RCS1 \parallel RCS2)$, and Max. VCS reference = 100 mV.

The V_{o_max} can be set by :

$$RVS1 = RVS2 \times (V_{o_max} - 2.5\ V) / 2.5\ V \quad (eq. 6)$$

Which Max. V_{VS} reference = 2.5 V.

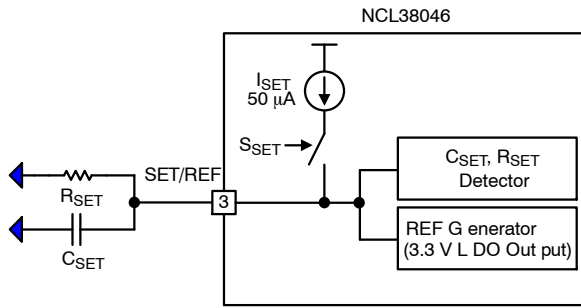

Figure 11. NCL38046 Dimming Curve Setting

At startup, 50 µA ISET sources SET/REF pin and the external RSET and CSET are detected to set the internal parameters. Then, SET sequence is terminated and SET/REF pin out is 3.3 V by internal LDO. The dimming curve will be setting by CSET :

Table 1.

CSET Function	
CSET	Dimming Curve
0 nF	Linear
1.2 nF	Logarithm

For the dimming curve, the modulator input signal, mod_{IN}, have an effective input range between 10% and 90%. When mod_{IN} is 10%, mod_{OUT} clamped to 1% by mod_{OUT}(MIN). When mod_{IN} is lower than 3%, NCL38046 enters STBY mode.

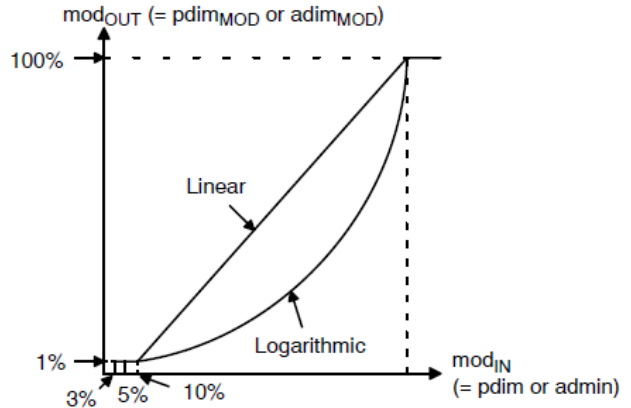

Figure 12. Dimming Curve

LLC TRANSFORMER DESIGN

Table 2. LLC TRANSFORMER

Pos.	Identification	Material	Turns	Turns in Total	Size	Winding Allowance	Tensile Force Required	Speed	Winding Point		Remarks
									Beginning	End	
1	NP1	TIW	11	22	0.4 mm				4	5	Two layers
2	Z1	tape	1	1	11 mm						
3	Vcc	TIW	3	3	0.2 mm				2	3	
4	Z2	tape	1	1	11 mm						
	NS1	TIW	3	3	0.2 mm				12	11	
	Z3	tape	2	2	11 mm						
9	NS2	copper wire	7	7	0.1 × 30 mm				start 7, end 9 start 8 end 10		
10	Z4	tape	1	1	11 mm						
	NP2	TIW	11	11					5	6	
11	Z5	tape	2	2	8 mm						
	Bobbin: PQ2616 Cores:										
	LH = 550 µH Lk = 5 µH										

PFC CHOKE DESIGN

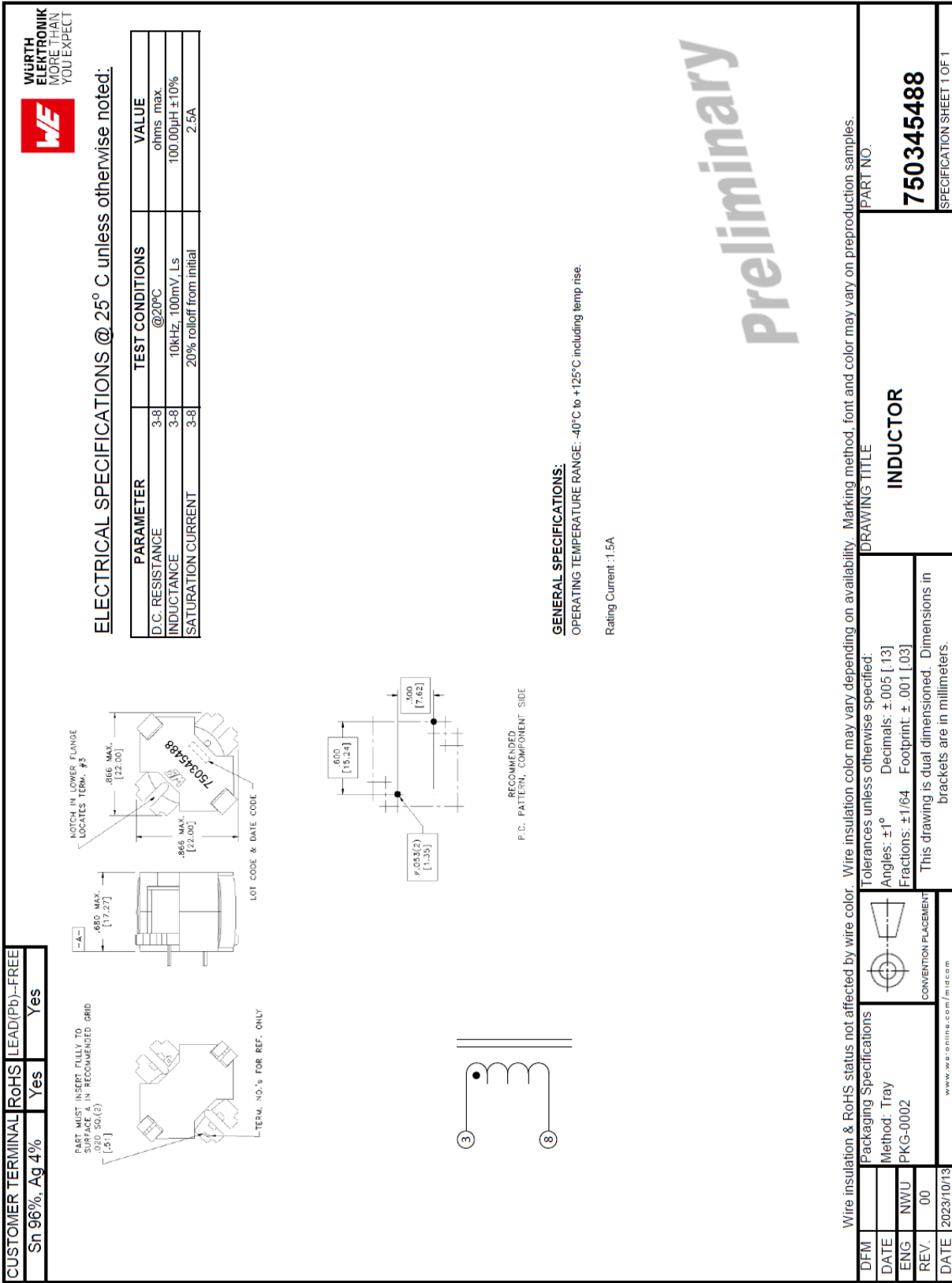

Figure 13. PFC Choke Design

LLC RESONANTCHOKE DESIGN

Table 3. RESONANT CHOKE

Pos.	Identification	Material	Turns	Turns in Total	Size	Winding Allowance	Tensile Force Required	Speed	Winding Point		Remarks
									Beginning	End	
1	NP	litz wire	20	20	0.1 mm × 25				6	14	
2	Z1	tape	1	1	14 mm						
Bobbin: RM8											
Cores:											
LH = 100 μH ±7% (10 kHz)											

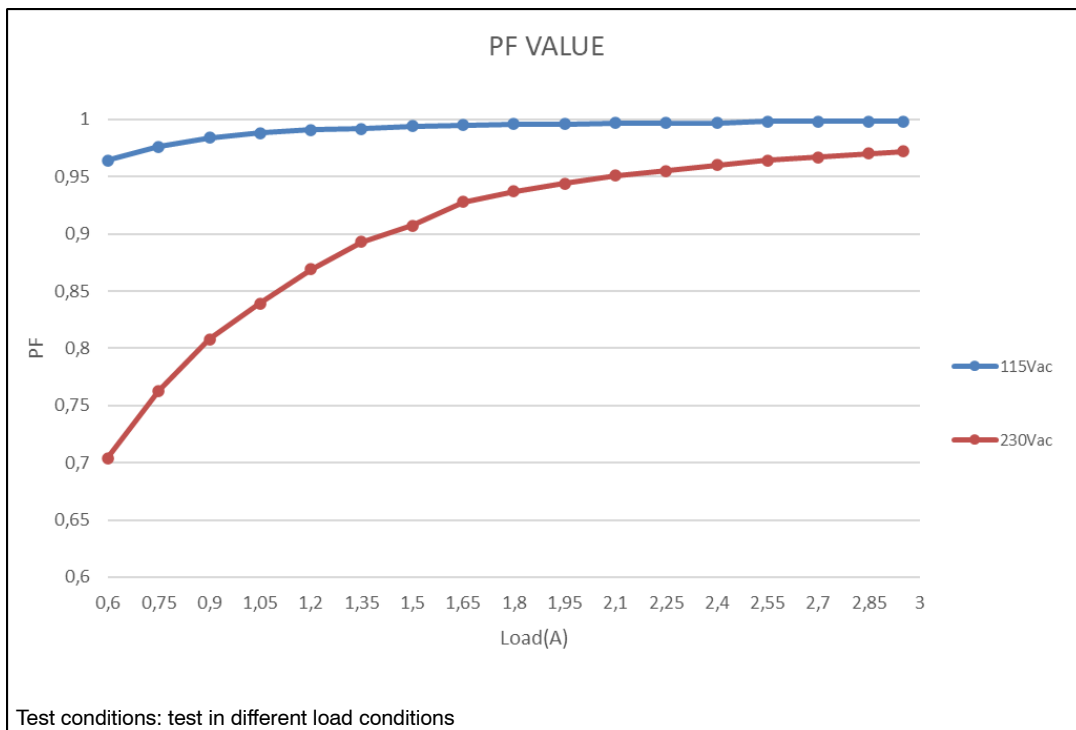

Figure 14. PFC Value in Different Load

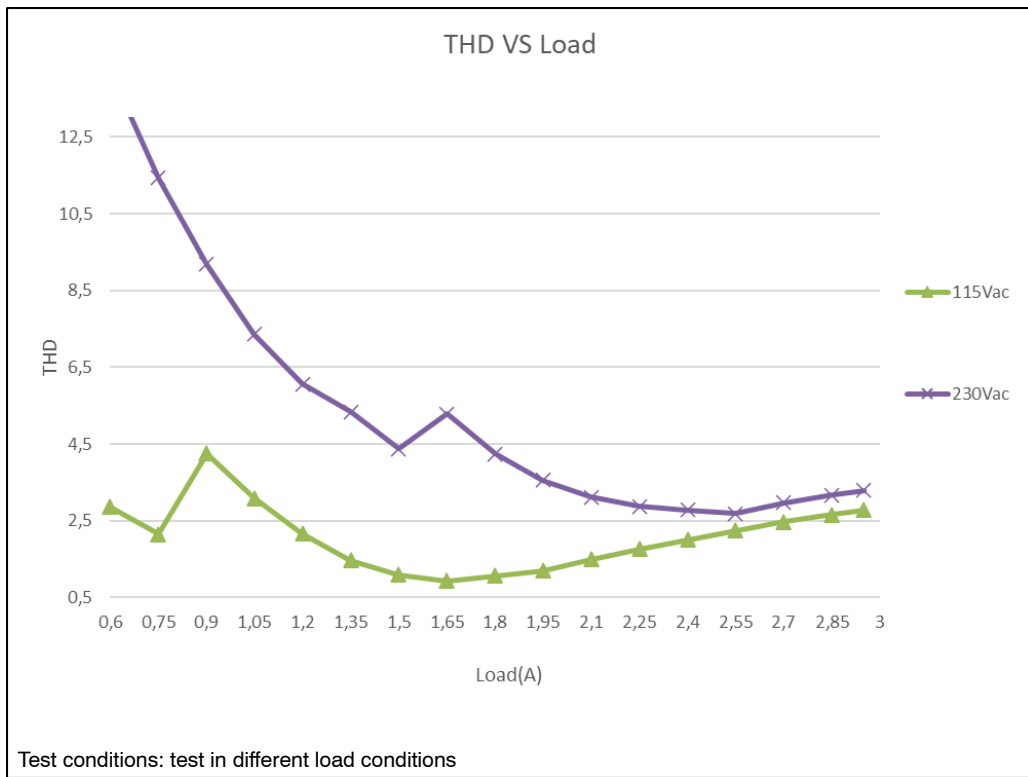

Figure 15. THD in Different Load

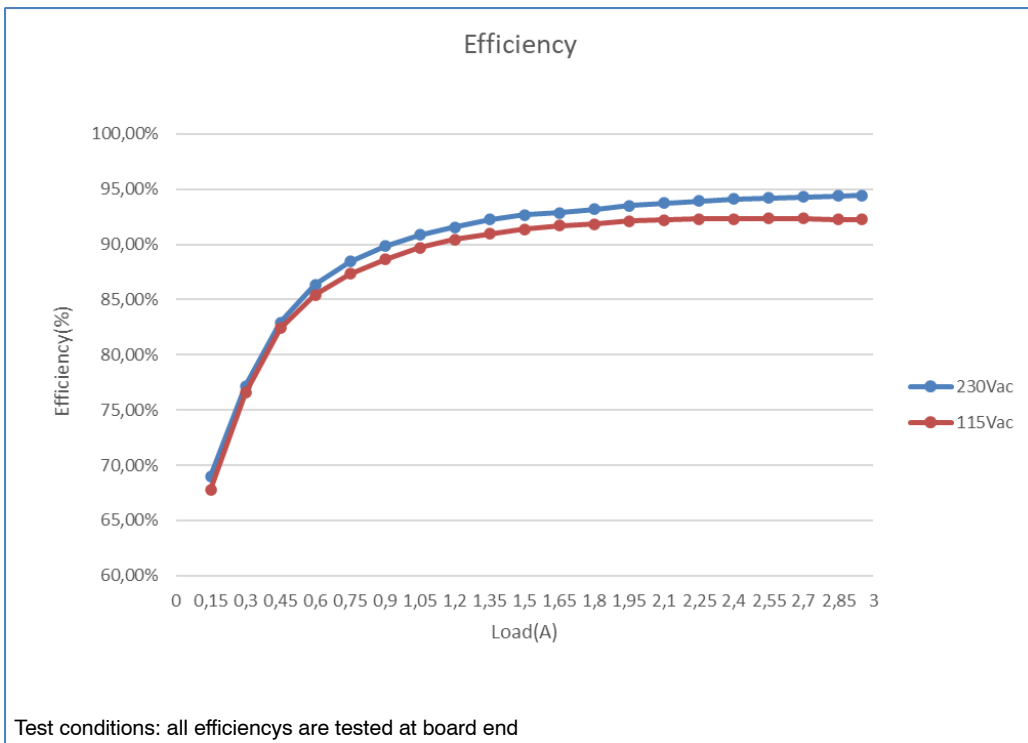

Figure 16. Efficiency Curve

PFC MOSFET D-S Wave-Form:
(CH2: DS, CH3: CS)

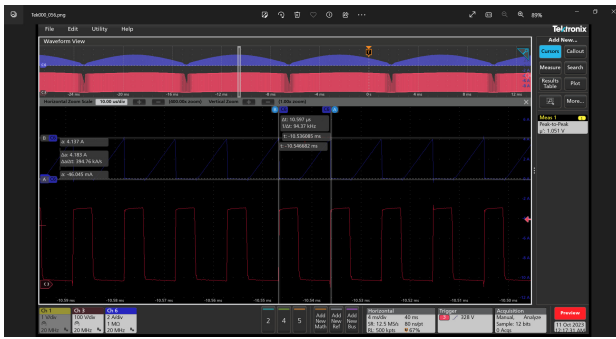

Figure 17. 115 Vac Input & Full Load



Figure 18. 230 Vac Input & Full Load

LLC MOSFET D-S Wave-Form:
(CH3: Mlow D-S, CH6: Resonant Current)

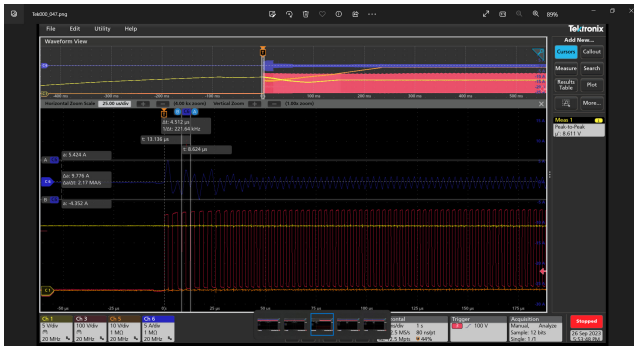

Figure 19. Startup @ 50 V/3 A

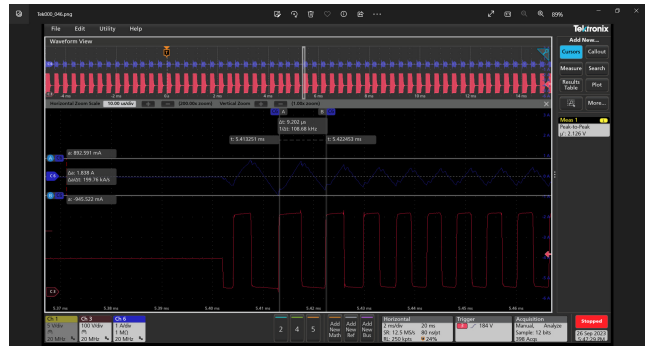

Figure 20. Skip Mode @ 50 V/0.06 A Load

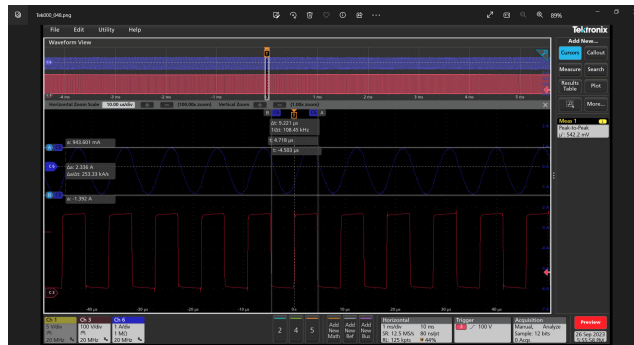

Figure 21. 43 V/3 A Load

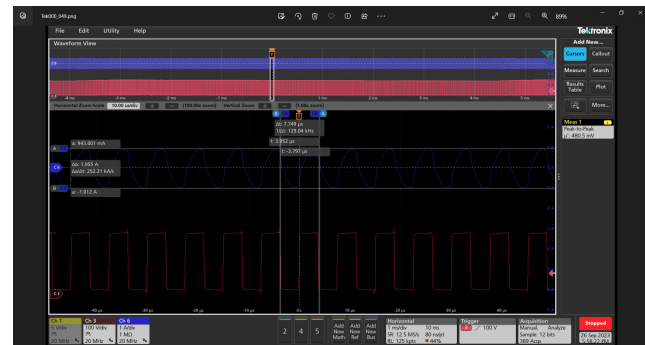

Figure 22. 32 V/3 A Load

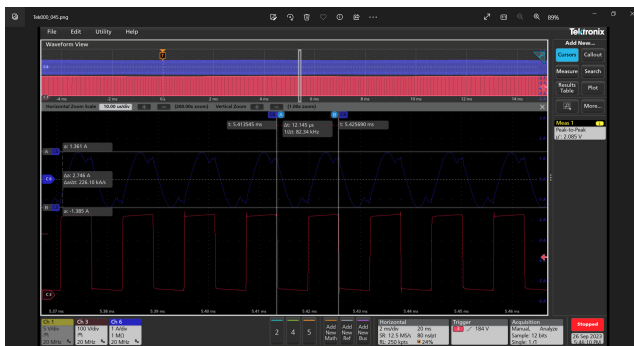

Figure 23. 50 V/3 A

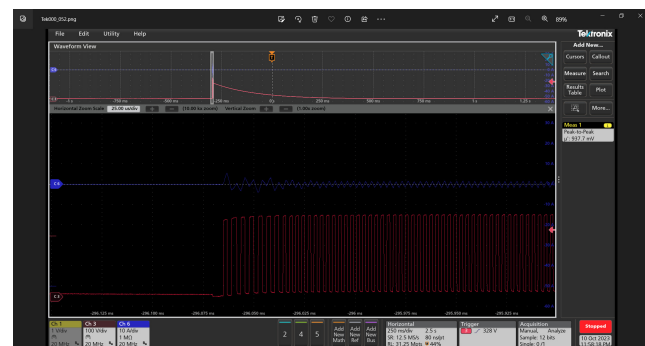

Figure 24. OCP Protection

EVBUM2896/D

Output Voltage Ripple:
(CH1: Output Voltage Ripple)



Figure 25. 50 V/3 A

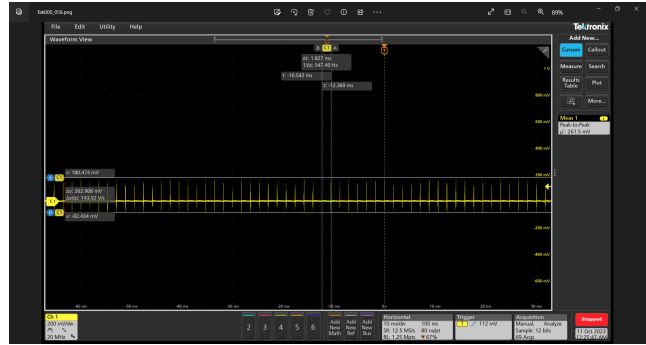

Figure 26. 50 V/0 A

BOM

Designator(Main Board)	Quantity	Description	Value	Tolerance	Footprint	Manufacturer	Manufacturer Part Number	LC PN.	单价/元
NTC1	1	NTC	2.5ohm	1%	7mm	TKS	SCK102R55AMSY	C211174	
F1	1	FUSE	Micro Fuse 3.15A/250VAC	NC	Axial Lead	LANSON(浪胜)	SMT1315A	C182453	
L1	1	Filter	90uH/4A	20%	10mm*20mm	WE	7447013	No	
L4	1	PFC choke	250uH	10%	PQ2616	TDG	750345488	No	
L2	1	filter	2*220uH/3A	20%		WE	750344558	No	
L3	1	filter	10mH/4A	20%	10*13	SANCI	SQ1515/10mH	No	
L5	1	Resonant choke	100uH	7%	RM8	WE	750345488	No	
T1	1	LLC Transformer	550uH	7%	PQ2616	TDG	550uH	No	
CX1,CX2	2	Film Capacitor,X2, Radial	474/275Vac	10%	L'W:18*6cm,Pin distance 1.5cm	WE	890334025039CS	Yes	
R13	1	Resistor	0.2R/2512	1%	2512	FOJAN(富捷)	FRL2512FR180TS	C2934365	
R8,R9,R20,R22,R26,R27,R29,R32,R35,R36,R39,R45,R47,R55	14	Resistor	10/0603	1%	0603	UNI-ROYAL(厚声)	0603WAF100JT5E	C22859	
R31	1	Resistor	100/0603	1%	0603	UNI-ROYAL(厚声)	0603WAF1000T5E	C22775	
R41	1	Resistor	100K/0603	1%	0603	UNI-ROYAL(厚声)	0603WAF1003T5E	C25803	
R52	1	Resistor	2.2K/0603	1%	0603	UNI-ROYAL(厚声)	0603WAF2201T5E	C4190	
R25,R42,R53,R104	4	Resistor	10K/0603	1%	0603	UNI-ROYAL(厚声)	0603WAF1002T5E	C25804	
R59,R60	2	Resistor	66mR/2512	1%	2512	UNI-ROYAL(厚声)	66mR/2512	Yes	
R14	1	Resistor	13K/0603	1%	0603	UNI-ROYAL(厚声)	0603WAF1302T5E	C22797	
R10	1	Resistor	150R/0603	1%	0603	UNI-ROYAL(厚声)	0603WAF1500T5E	C22808	
R3	1	Resistor	15K/0603	1%	0603	UNI-ROYAL(厚声)	0603WAF1502T5E	C22809	
R17	1	Resistor	56K/0603	1%	0603	UNI-ROYAL(厚声)	0603WAF5602T5E	C23206	
R37,R38	2	Resistor	15R/0803	1%	0603	UNI-ROYAL(厚声)	0603WAF150JT5E	C22810	
R21	1	Resistor	160K/0603	1%	0603	UNI-ROYAL(厚声)	0603WAF1603T5E	C22813	
R28,R54	2	Resistor	1K/0603	1%	0603	UNI-ROYAL(厚声)	0603WAF1001T5E	C21190	
R43	1	Resistor	0R/2512	1%	2512	UNI-ROYAL(厚声)	25121WJ0000T4E	C25469	
R44	1	Resistor	100K/1206	1%	1206	UNI-ROYAL(厚声)	1206W4F1003T5E	C17900	
R1,R11	2	Resistor	1M5/0805	1%	0805	UNI-ROYAL(厚声)	0805W8F1504T5E	C26110	
R56	1	Resistor	2.2K/0603	1%	0603	UNI-ROYAL(厚声)	0603WAF2201T5E	C4190	

EVBUM2896/D

BOM (continued)

R2,R5,R12,R19,R24,R33,R34,R40,R46,R48	10	Resistor	20K/0603	1%	0603	UNI-ROYAL(厚声)	0603WAF2002T5E	C4184	
R57	1	Resistor	56K/0603	1%	0603	UNI-ROYAL(厚声)	0603WAF5602T5E	C23206	
R52	1	Resistor	2K2/0805	1%	0603	UNI-ROYAL(厚声)	0805W8F2201T5E	C17520	
R30	1	Resistor	2K4/0603	1%	0603	UNI-ROYAL(厚声)	0603WAF2401T5E	C22940	
R15,R16	2	Resistor	2K7/0805	1%	0805	UNI-ROYAL(厚声)	0805W8F2701T5E	C17530	
R6	1	Resistor	2M2/0805	1%	0805	UNI-ROYAL(厚声)	0805W8F2204T5E	C26113	
R7	1	Resistor	2M4/0805	1%	0805	UNI-ROYAL(厚声)	0805W8F2404T5E	C17527	
R123	1	Resistor	30K/0603	1%	0603	UNI-ROYAL(厚声)	0603WAF3002T5E	C22984	
R18,R23	2	Resistor	10/0603	1%	0603	UNI-ROYAL(厚声)	0603WAF1001T5E	C22859	
R4	1	Resistor	56K/0603	1%	0603	UNI-ROYAL(厚声)	0603WAF5602T5E	C23206	
C15	1	Ceramic Capacitor,NPO,SMD	100pF ±5% 1kV	5%	1206	YAGEO(国巨)	CC1206JKNPOCBN101	C107173	
C11,C12,C24,C27	4	Ceramic Capacitor,NPO,SMD	100pF ±5% 50V	5%	603	YAGEO(国巨)	CC0603JRNPO98B101	C14665	
C3,C9,C10,C13,C21	5	Ceramic Capacitor,NPO,SMD	1nF ±10% 50V	10%	0603	YAGEO(国巨)	CC0603KRX7R98B102	C100040	
C17,C19	2	Ceramic Capacitor,NPO,SMD	1nF ±10% 50V	10%	0603	YAGEO(国巨)	CC0603KRX7R98B102	C100040	
C14	1	Ceramic Capacitor,NPO,SMD	100nF ±10% 50V	10%	0603	YAGEO(国巨)	CC0603KRX7R98B104	C14663	
C5	1	Ceramic Capacitor,NPO,SMD	1uF ±10% 25V	10%	0805	YAGEO(国巨)	CC0603KRX5R88B105	C14664	
C18,C23,C26	3	Ceramic Capacitor,NPO,SMD	1uF ±10% 25V	10%	0805	YAGEO(国巨)	CC0603KRX5R88B105	C14664	
C16	1	Ceramic Capacitor,NPO,SMD	10nF ±10% 50V	10%	0603	YAGEO(国巨)	CC0603KRX7R98B103	C100042	
C4	1	Ceramic Capacitor,NPO,SMD	220nF ±10% 50V	10%	0603	YAGEO(国巨)	CC0603KRX7R98B224	C107083	
C7	5	Ceramic Capacitor,NPO,SMD	2.2uF ±10% 25V	10%	0603	FH(风华)	0603B225K250NT	C99228	
C8	1	Ceramic Capacitor,NPO,SMD	22pF ±5% 50V	10%	0603	YAGEO(国巨)	CC0603JRNPO98B220	C105620	
C28	1	Ceramic Capacitor,NPO,SMD	4.7uF 50V	10%	0805	FH(风华)	0805B475K500NT	C2991173	
C2	1	Ceramic Capacitor,NPO,SMD	10nF ±10% 50V	10%	0603	YAGEO(国巨)	CC0603KRX7R98B103	C100042	
C42	1	Ceramic Capacitor,NPO,SMD	100nF ±10% 50V	10%	0603	YAGEO(国巨)	CC0603KRX7R98B104	C14663	
C6,C25	2	Ceramic Capacitor,NPO,SMD	1uF ±10% 25V	10%	0603	FH(风华)	0603B105K250NT	C59302	
C20,C47	2	Ceramic Capacitor,NPO,SMD	22nF ±10% 50V	10%	0603	FH(风华)	0603B223K500NT	C77571	
EC1,EC2	2	Aluminum Electrolytic Capacitor	56uF ±20% 450V	20%	E-cap	Ymin(永铭)	LKMI2502W560MF	C443362	
C1,C22	2	X-CAP	474/450V	10%	X-CAP	WE	890334025039CS	Yes	
EC3	1	Aluminum Electrolytic Capacitor	68u/50V	20%	E-cap	WE	860010573006	No	
EC5	1	Aluminum Electrolytic Capacitor	100u/35V	20%	E-cap	WE	860010573007	No	
EC4,EC6	2	Aluminum Electrolytic Capacitor	62V/470uF	20%	E-cap	WE	860010778020	No	
D3,D5	2	Diode bridge	DF1052	NC	DFN26	ON	DF1052	No	
CR2	1	Film Capacitor	22nF ±5% 630V	5%	1210	TDK	C3225C0G2J223JT000N	C338114	
D4,D7,D10,D16,D19	4	Diode	电压:100V 电流:150mA T4	NC	SOD323	Ci(江苏长电/长晶)	1N4148WS	C2128	
D2,D12,D13,D14	4	Diode	ES1J	NC	SMA	ON	ES1J	C232830	
D6,D8,D9,D15,D18,D21	6	Diode	1N4148	NC	SOD123	ON	1N4148W	C2099	
D1	1	SiC Diode	STPSC4H065B-TR	NC	TO252	ST	STPSC4H065B-TR	C191032	
D17,D20	2	Diode	BZT52C15	NC	SOD-123	Ci(江苏长电/长晶)	BZT52C15	C2104	
Q1,Q2	2	N-MOSFET	FDMS8D8N15C	NC	DFN5*6	ON	FDMS8D8N15C	No	
Q3,Q8	2	BJT	BSS138	NC	SOT23	Ci(江苏长电/长晶)	BSS138	C78284	
Q5,Q6,Q7	3	N-MOSFET	FCD260N65	NC	TO252	ON	FCD260N65	No	
U11	1	Feedback loop controller	NCL38046	NC	SOIC-8	ON	NCL38046AP	No	
U1	1	PFC controller	NCL2801	NC	SOIC-8	ON	NCL2801CDA	No	
U3	1	LLC controller	NCL30159	NC	SOIC-16	ON	NCL30159AP	No	
U6	1	SR Controller	NCP4318	NC	SOIC-8	ON	NCP4318ALC	No	
CY1	1	Y CAP	Y1/2.2nF	NC		WMCC(万明)	CKF222M2GA80AARC	C7430023	
OPT1	1	Optical coupler	FODM1007	NC	LSOP4	ON	FODM1007	No	

REFERENCES

onsemi datasheet for [NCL30159](#), [NCL38046](#), [NCL2801](#).

onsemi, **Onsemi**, and other names, marks, and brands are registered and/or common law trademarks of Semiconductor Components Industries, LLC dba "**onsemi**" or its affiliates and/or subsidiaries in the United States and/or other countries. **onsemi** owns the rights to a number of patents, trademarks, copyrights, trade secrets, and other intellectual property. A listing of **onsemi**'s product/patent coverage may be accessed at www.onsemi.com/site/pdf/Patent-Marking.pdf. **onsemi** is an Equal Opportunity/Affirmative Action Employer. This literature is subject to all applicable copyright laws and is not for resale in any manner.

The evaluation board/kit (research and development board/kit) (hereinafter the "board") is not a finished product and is not available for sale to consumers. The board is only intended for research, development, demonstration and evaluation purposes and will only be used in laboratory/development areas by persons with an engineering/technical training and familiar with the risks associated with handling electrical/mechanical components, systems and subsystems. This person assumes full responsibility/liability for proper and safe handling. Any other use, resale or redistribution for any other purpose is strictly prohibited.

THE BOARD IS PROVIDED BY ONSEMI TO YOU "AS IS" AND WITHOUT ANY REPRESENTATIONS OR WARRANTIES WHATSOEVER. WITHOUT LIMITING THE FOREGOING, ONSEMI (AND ITS LICENSORS/SUPPLIERS) HEREBY DISCLAIMS ANY AND ALL REPRESENTATIONS AND WARRANTIES IN RELATION TO THE BOARD, ANY MODIFICATIONS, OR THIS AGREEMENT, WHETHER EXPRESS, IMPLIED, STATUTORY OR OTHERWISE, INCLUDING WITHOUT LIMITATION ANY AND ALL REPRESENTATIONS AND WARRANTIES OF MERCHANTABILITY, FITNESS FOR A PARTICULAR PURPOSE, TITLE, NON-INFRINGEMENT, AND THOSE ARISING FROM A COURSE OF DEALING, TRADE USAGE, TRADE CUSTOM OR TRADE PRACTICE.

onsemi reserves the right to make changes without further notice to any board.

You are responsible for determining whether the board will be suitable for your intended use or application or will achieve your intended results. Prior to using or distributing any systems that have been evaluated, designed or tested using the board, you agree to test and validate your design to confirm the functionality for your application. Any technical, applications or design information or advice, quality characterization, reliability data or other services provided by **onsemi** shall not constitute any representation or warranty by **onsemi**, and no additional obligations or liabilities shall arise from **onsemi** having provided such information or services.

onsemi products including the boards are not designed, intended, or authorized for use in life support systems, or any FDA Class 3 medical devices or medical devices with a similar or equivalent classification in a foreign jurisdiction, or any devices intended for implantation in the human body. You agree to indemnify, defend and hold harmless **onsemi**, its directors, officers, employees, representatives, agents, subsidiaries, affiliates, distributors, and assigns, against any and all liabilities, losses, costs, damages, judgments, and expenses, arising out of any claim, demand, investigation, lawsuit, regulatory action or cause of action arising out of or associated with any unauthorized use, even if such claim alleges that **onsemi** was negligent regarding the design or manufacture of any products and/or the board.

This evaluation board/kit does not fall within the scope of the European Union directives regarding electromagnetic compatibility, restricted substances (RoHS), recycling (WEEE), FCC, CE or UL, and may not meet the technical requirements of these or other related directives.

FCC WARNING – This evaluation board/kit is intended for use for engineering development, demonstration, or evaluation purposes only and is not considered by **onsemi** to be a finished end product fit for general consumer use. It may generate, use, or radiate radio frequency energy and has not been tested for compliance with the limits of computing devices pursuant to part 15 of FCC rules, which are designed to provide reasonable protection against radio frequency interference. Operation of this equipment may cause interference with radio communications, in which case the user shall be responsible, at its expense, to take whatever measures may be required to correct this interference.

onsemi does not convey any license under its patent rights nor the rights of others.

LIMITATIONS OF LIABILITY: **onsemi** shall not be liable for any special, consequential, incidental, indirect or punitive damages, including, but not limited to the costs of requalification, delay, loss of profits or goodwill, arising out of or in connection with the board, even if **onsemi** is advised of the possibility of such damages. In no event shall **onsemi**'s aggregate liability from any obligation arising out of or in connection with the board, under any theory of liability, exceed the purchase price paid for the board, if any.

The board is provided to you subject to the license and other terms per **onsemi**'s standard terms and conditions of sale. For more information and documentation, please visit www.onsemi.com.

ADDITIONAL INFORMATION

TECHNICAL PUBLICATIONS:

Technical Library: www.onsemi.com/design/resources/technical-documentation
onsemi Website: www.onsemi.com

ONLINE SUPPORT: www.onsemi.com/support

For additional information, please contact your local Sales Representative at www.onsemi.com/support/sales