

NCV75215R1GEVK – Ultrasonic Parking Assist Kit

EVBUM2895/D

NCV75215R1GEVK is Ultrasonic Parking Assist Kit to present full performance of the chip. User-friendly Graphical User Interface (GUI) makes it possible to operate the evaluation kit in an easy way. Easy access to several signals makes debugging very easy and gives you the possibility to understand full set of features of the chip.

Features

- Measurement Distance Range from 0.25 m to 4.5 m (Depends on External Parts)
- Acoustic Noise Monitoring
- Diagnosis of Transducer Performance
- Junction Temperature Monitoring and Thermal Shutdown
- Transducer Center Frequency Range from 35 to 90 kHz
- Direct and Indirect Measurement Modes
- EEPROM Memory for Configuration Setting and User Data
- Rx Gain Adjustable in 0.5 dB Steps in the Range from 50 to 110 dB
- Time-dependent Threshold Values for the Sensitivity Control
- Dynamic (Time-dependent) Gain Control
- Tx Current Range Adjustable from 50 mA to 350 mA
- Programmable Ultrasonic Burst Length
- On-chip Bidirectional I/O Line

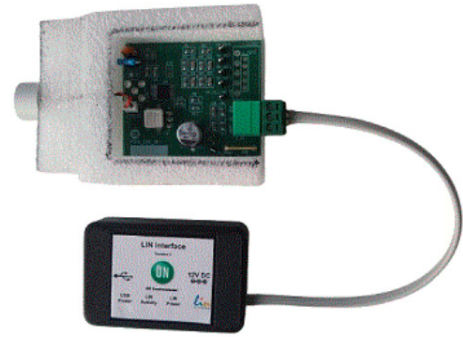

Figure 1. Ultrasonic Parking Assist Kit

Table 1. RECOMMENDED OPERATING CONDITIONS

Symbol	Parameter	Min	Typ	Max	Unit
VSUP	DC supply voltage	6	12	18	V
IO	I/O line voltage	0		VSUP	V
DRVA	Transmitter phase A output voltage	0		2xVSUP	V
DRVB	Transmitter phase B output voltage	0		2XVSUP	V
DRVC	Transmitter common output voltage	0		VSUP	V
TA	Ambient temperature under bias	-40		85	°C

Functional operation above the stresses listed in the Recommended Operating Ranges is not implied. Extended exposure to stresses beyond the Recommended Operating Ranges limits may affect device reliability.

NCV75215GEVK works together with USB-LIN Interface.

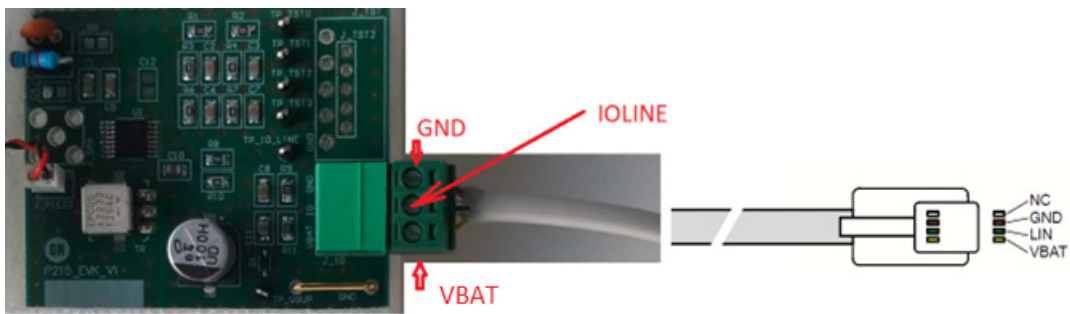

Figure 2. Connection of NCV75215GEVK to USB-LIN Interface

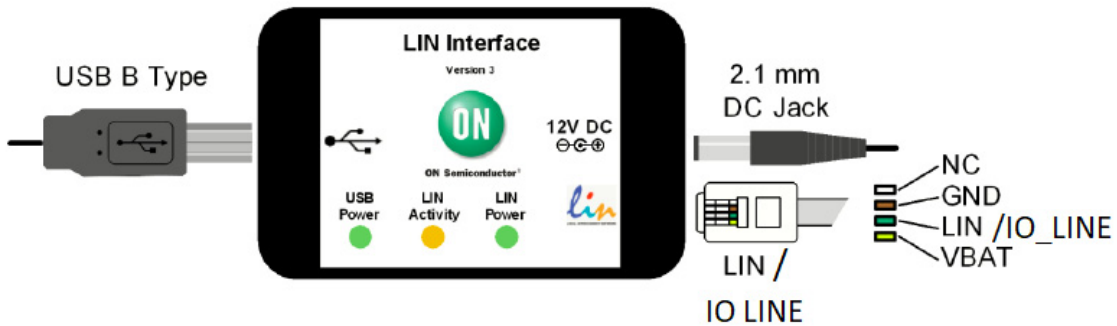

Figure 3. Connection of the USB-LIN to Power and PC

Getting Started

This section contains instructions for the NCV7430 setup configuration and first connection. Only a few steps need be proceeded to get fully working setup with NCV75215.

Please take the following steps to get a functional setup:

1. Install the NCV75215 Evaluation Software (see the NCV75215 Evaluation Software section for details). The USB drivers are included in the installation package. This installation requires administrator rights.

2. Connect LIN Interface to USB and wait until the device is installed. This step requires administrator rights.

3. Connect the boards according to figure below and run Evaluation software.

After running the file P215.exe, you will get following window – Figure 4:



Figure 4.

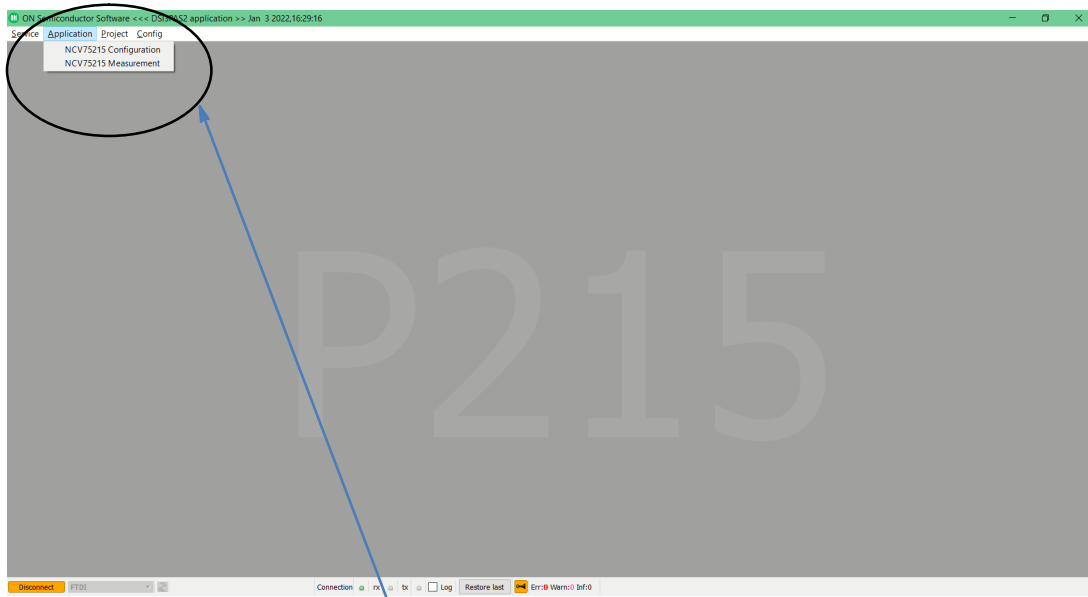

Open both these windows (NCV75215 Configuration Window as well as NCV75512 Measurement Window)

Figure 5.

You can use Configuration File provided together with this GUI – file name is P215_conf_v5.bench – Figure 6.

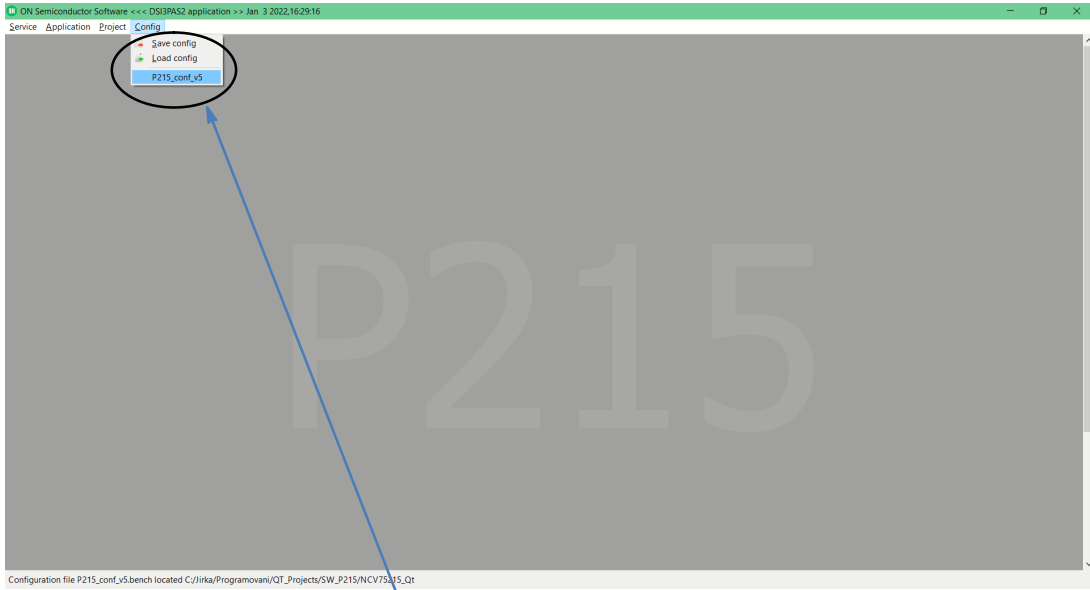

Open provided configuration file P215_conf_v5.bench by clicking Load config

Figure 6.

Now you can configure NCV75215 GUI by opening NCV75215 Configuration window: – Figure 7.

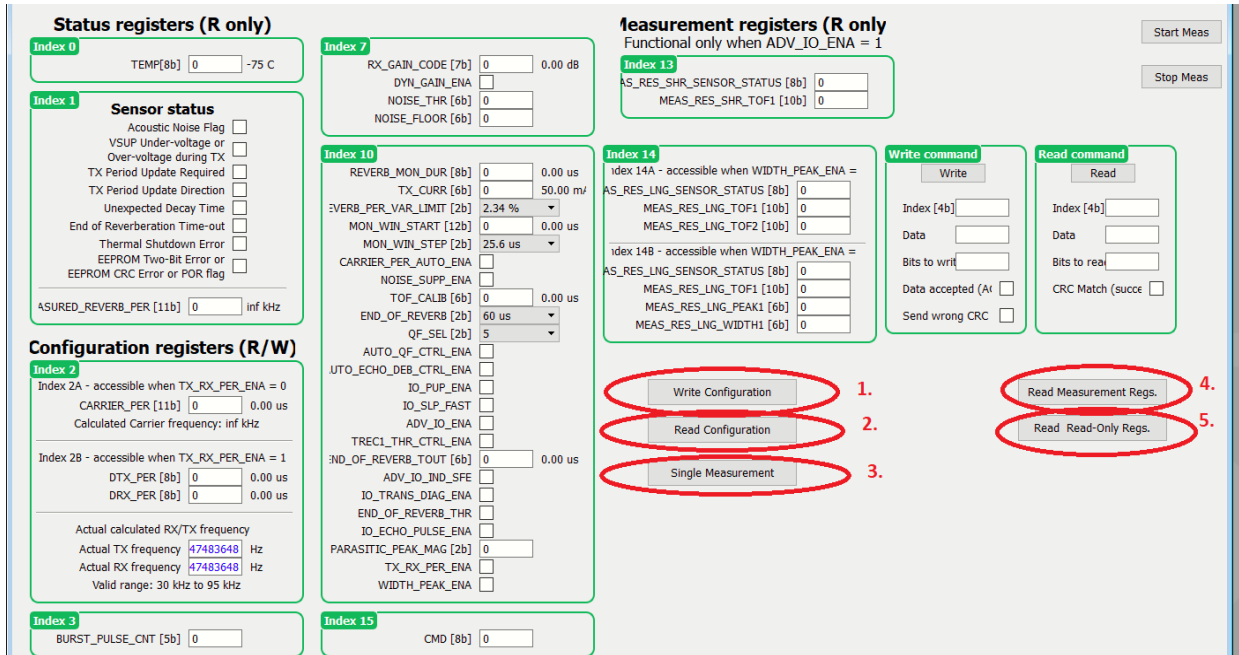

Figure 7.

In this window, you have access to all configuration registers. You can configure NCV75215 by clicking on button Write Configuration (item 1 on the picture). You can

read back configuration registers of NCV75215 by clicking on button Read Configuration (item 2). Then you can already start measurement by clicking on button Single

EVBUM2895/D

Measurement (*item 3*). When a measurement was performed, you can read Measurement registers (index 13 and 14) – by clicking on Read Measurement regs (*item 4*).

By clicking on Read Read-only regs (*item 5*), you can get chip's junction temperature.

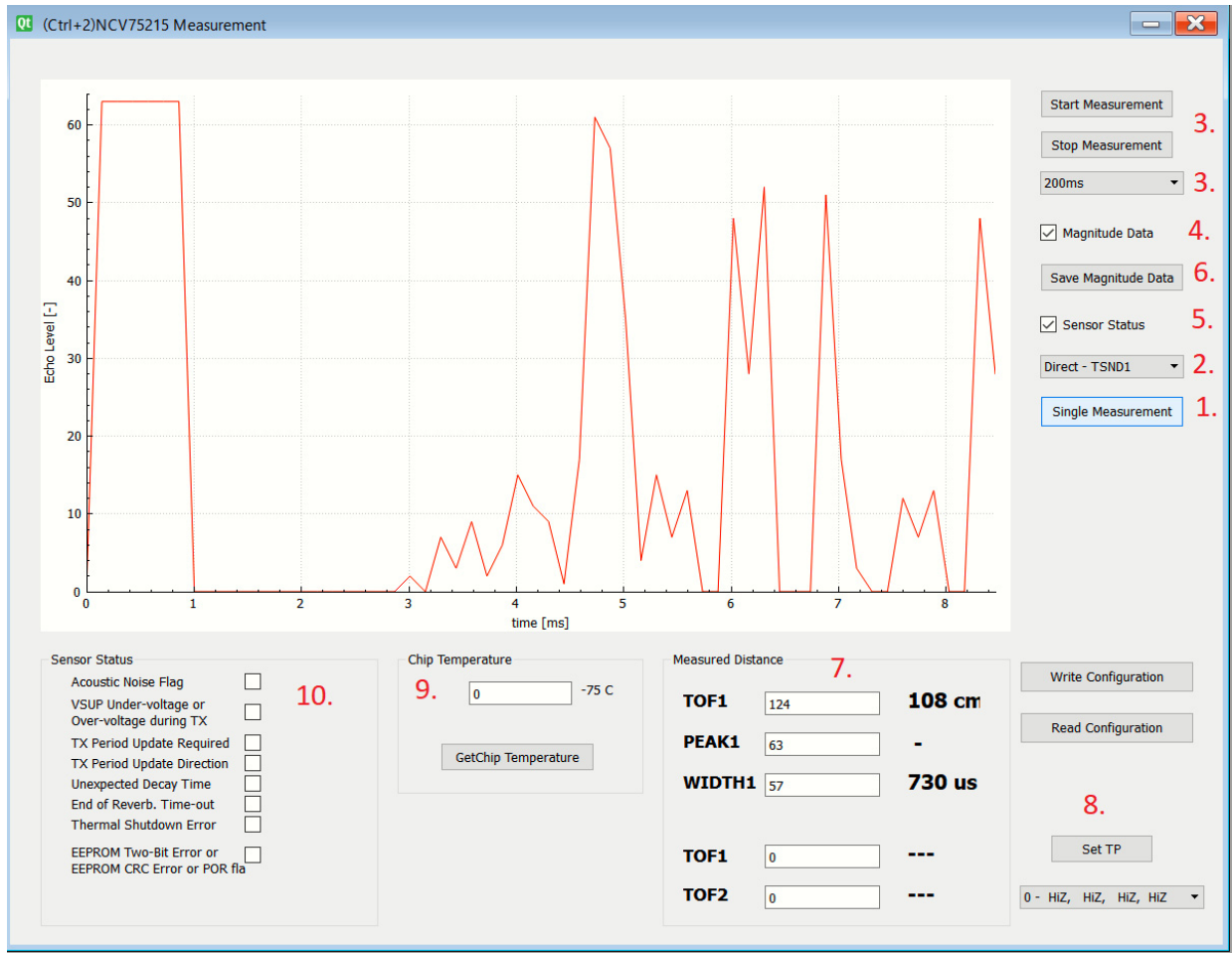

Figure 8.

Main Measurement window is present in Figure 8. You can perform single measurement by clicking on *Item 1*. *Item 2* selects the direct / indirect measurement. *Item 3* starts periodic measurements with period 200, 500 or 1000 ms. *Item 4* enables Magnitude data at each measurement *Item 5*

updates Sensor status at each measurement *Item 6* saves magnitude data into the csv file *Item 7* contains Measured distance *Item 8* selects Debugging output on TST0 to TST3 In *Item 9* you can read back chip's temperature *Item 10* shows sensor status.

External ULS Components Basics

Key factor to get good ultrasonic performance is to select transducer, transformer and other components.

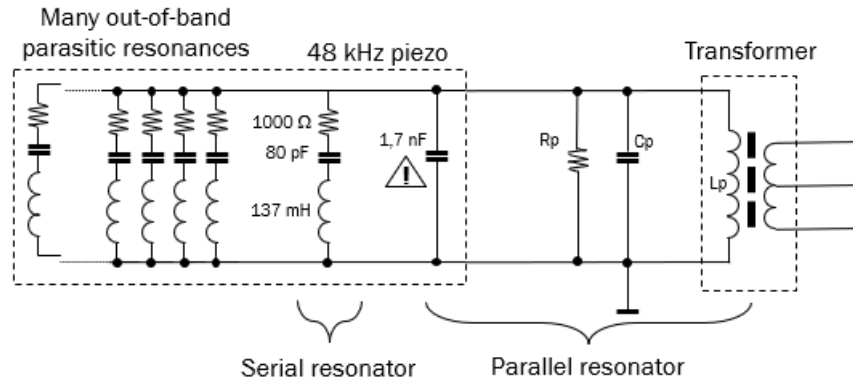

Figure 9.

You can find external components related to ultrasonic transducer in Figure 9. It is a coupled structure of 2 resonators. Parallel and serial resonators are tuned to the same frequency. The goal is to find Rp and Cp value to get optimal tuning. It is discussed below.

There is replacement circuit in dashed rectangle – there is visible main serial resonator with frequency 48 kHz and many out of band parasitic resonances. There is also visible capacitor of the transducer – 1.7 nF.

How to Tune Parallel Resonator

In previous chapter we checked the external coupling structure (components around ultrasonic transducer) – transformer, Rp and Cp. Typically we select transducer, transformer and calculate Rp and Cp. Cp value affects the resonant frequency of the parallel resonator – it can be calculated by Thomson formula:

$$f_R = \frac{1}{2\pi\sqrt{LC}} \quad [\text{Hz, H, F}] \quad (\text{eq. 1})$$

Where

- L is the inductance of the secondary side of the transformer,
- C is sum of transducer capacity and value of external capacitor Cp.

Example:

Let's take the transducer from Figure 9, we know that it has capacity of 1.7 nF and resonant frequency 48 kHz. Let's assume that our inductance of the secondary side of the transformer is 4 mH.

Then we calculate the value of the Cp as 1 nF to get close to the 48 kHz (in this case 48.4 kHz, using formula above) which is sufficient.

Rp selects coupling between serial and parallel resonator. Typically this resistor is 5.6 kΩ.

Properly tuned coupling structure is reflected in shortest reverberation time and therefore minimum achievable distance detected by ultrasonic measurements.

It is recommended to check reverberation on the TP_TST0 pin on NCV75215EVK.

• **Single Ended Analog RX Output on TST0 pin**

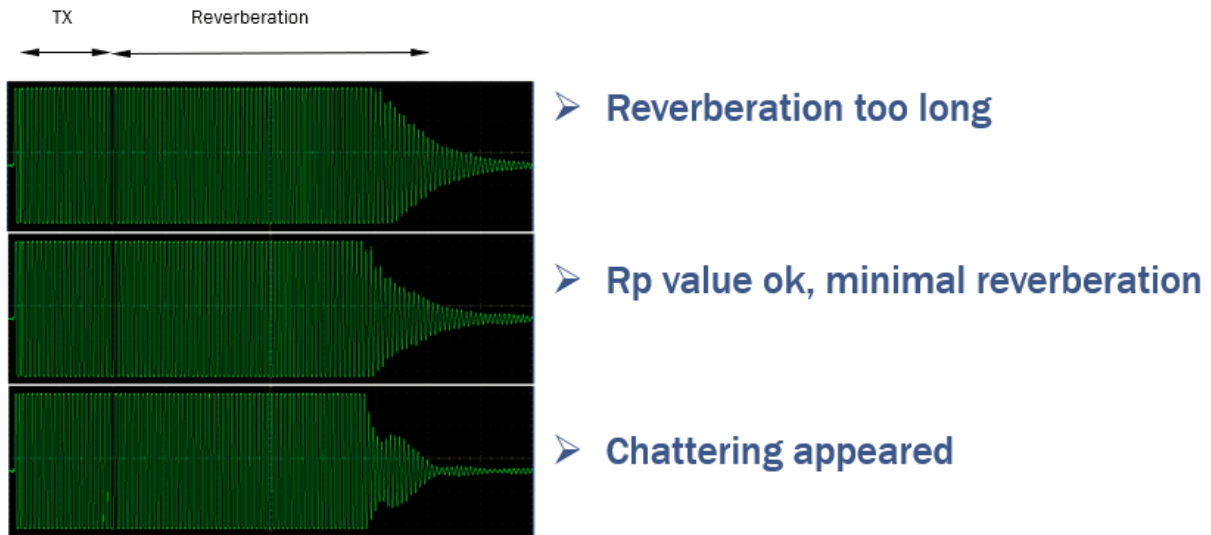

Figure 10.

Single ended Analog RX Output can be seen on TP_TST0 on NCV75215EVK.

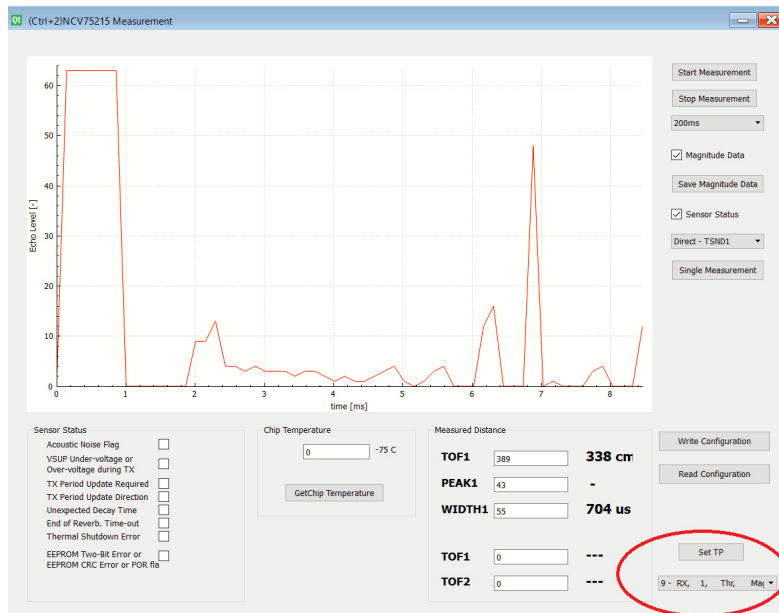

Figure 11.

Setting up Threshold Curve

Thresholds define a magnitude level of detectable echoes => Echo is ignored if it is below threshold. Main goal of the threshold curve is to detect the obstacle reliably and filter out noise .

Threshold curve consists of 12 sections. You can set threshold level and duration for each section. Thresholds are linearly interpolated – you can find the example of the threshold curve in Figure 12.

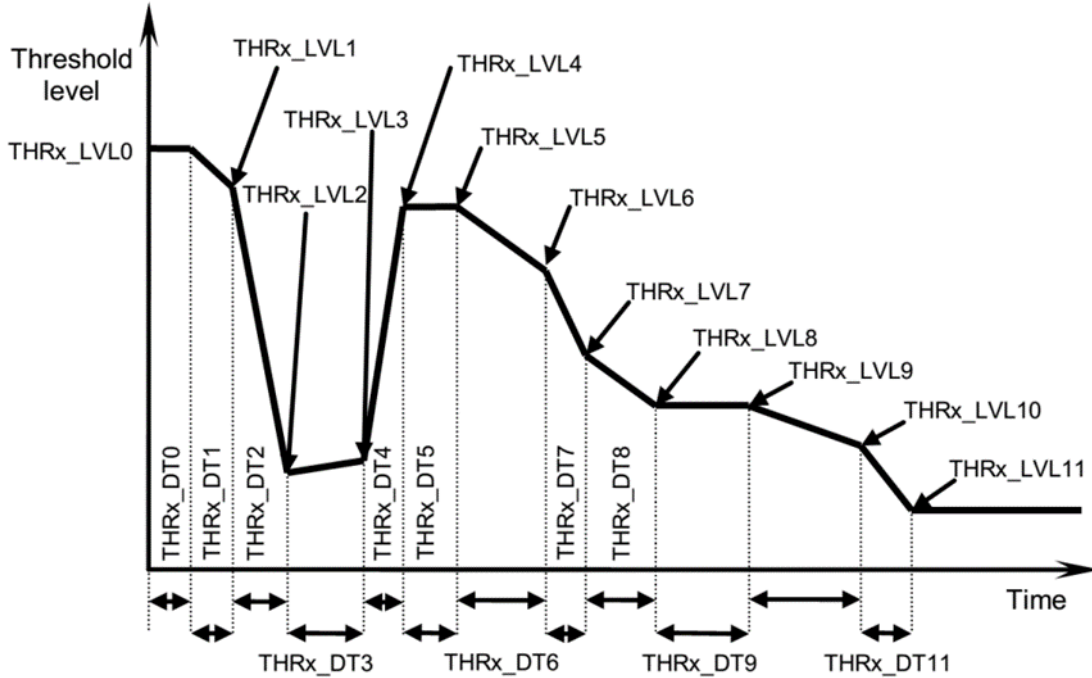

Figure 12.

y	0	1	2	3	4	5	6	7	8	9	10	11
THR_x_LVLy	33	33	33	33	33	32	28	20	15	12	8	4
THR_x_DTy	9	9	9	9	9	9	9	9	9	10	12	14

Figure 13. Example (1) of Setting the Threshold Curve

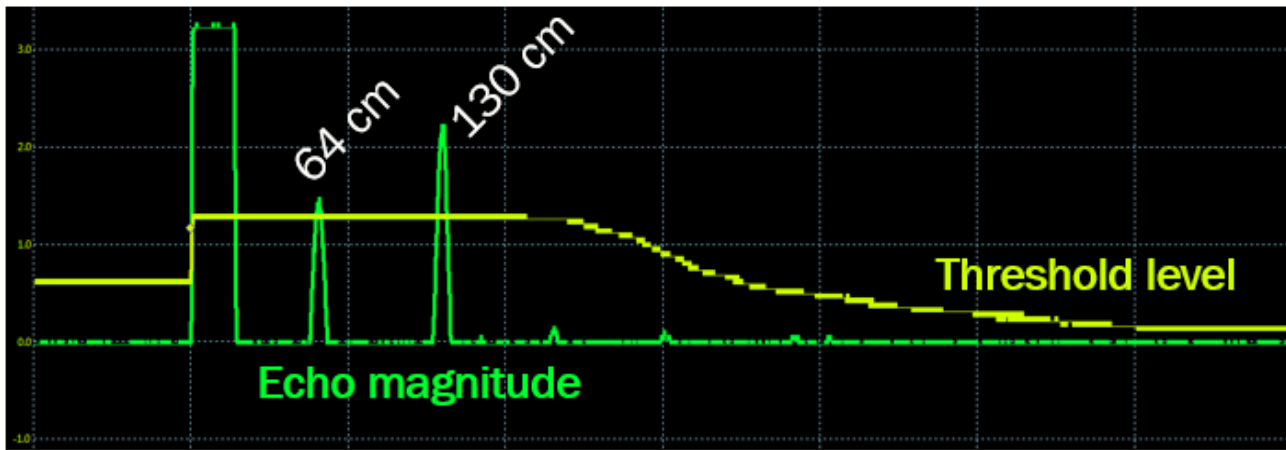

Figure 14.

In Figure 13 you can find example of setting the threshold curve (or level) and inf Figure 14 there is already a real measurement with 2 detected echoes – at 64 and 130 cm.

y	0	1	2	3	4	5	6	7	8	9	10	11
THR _x _LV _L y	33	45	45	33	33	10	28	20	15	12	8	4
THR _x _DT _y	10	6	6	6	6	9	9	9	9	10	12	14

Figure 15. Example (2) of Setting the Threshold Curve

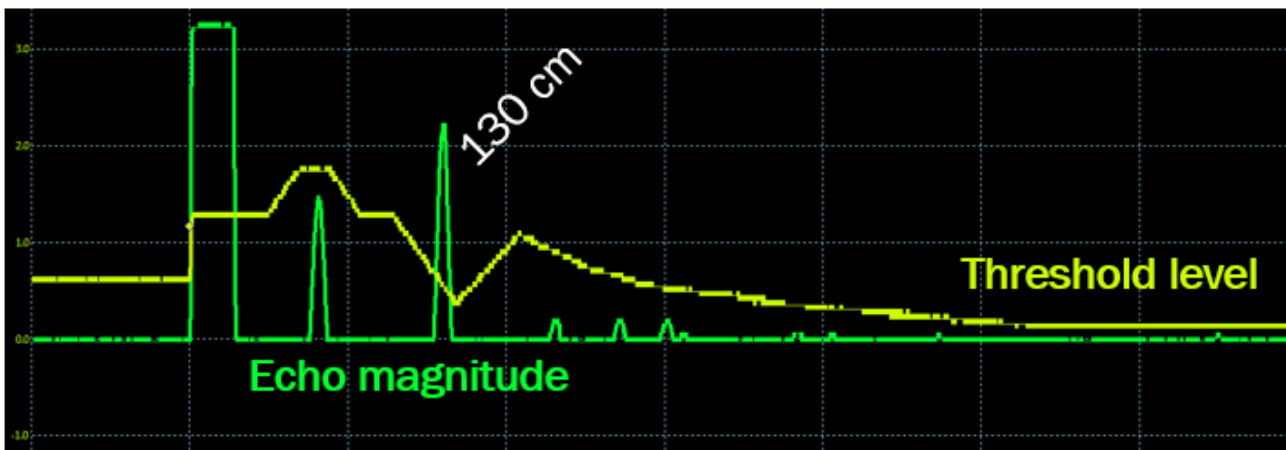

Figure 16.

In Figure 15 you can find example of setting the threshold curve (or level) and inf Figure 16 there is already a real measurement with just one detected echo – at 130 cm.

Dynamic gain is used to keep echo analog signal within dynamic range of digital processing. Main goal is to

compensate for attenuation of the sound waves in the air. Dynamic gain consists of 5 sections. You can set the starting gain, gain delta and duration for each section as it is visible in the examples below.

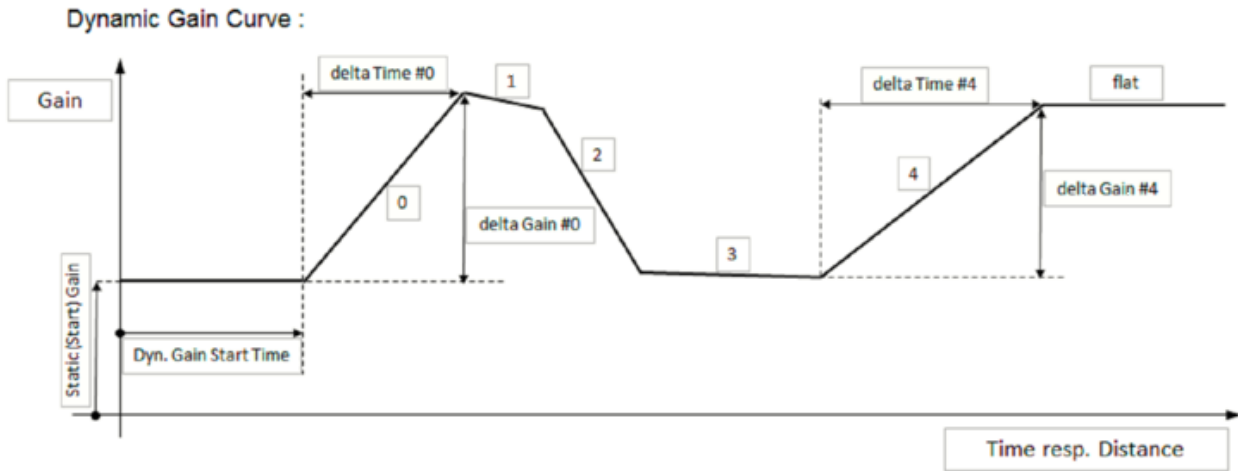

Figure 17.

	value	X	0	1	2	3	4
Static RX_GAIN_code	33	DELTA_GAIN_x	33	45	45	33	33
DYN_GAIN_start	10	DTx	8	8	8	8	12

Figure 18. Example (1) of Setting the Gain Curve

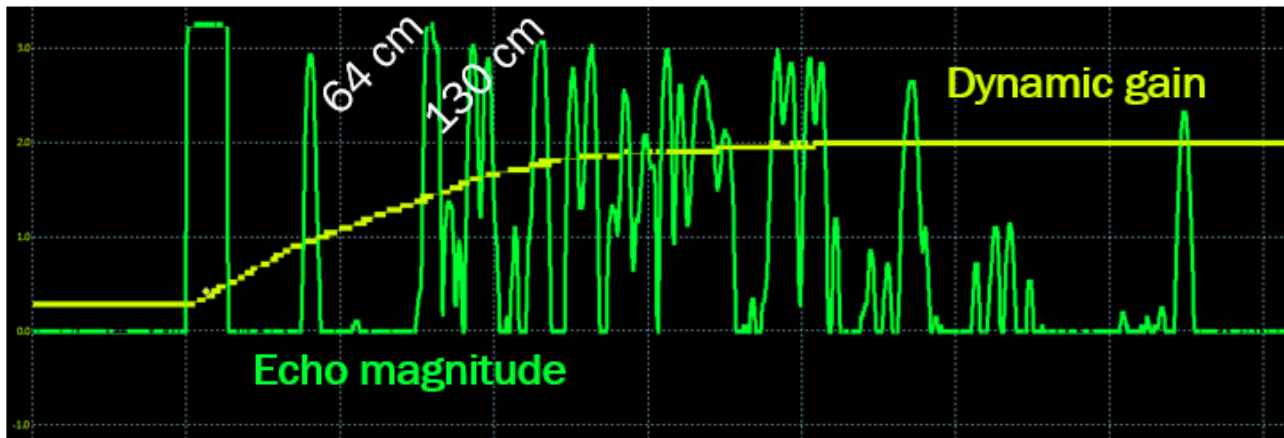

Figure 19.

In Figure 18 you can find example of setting the gain curve and in Figure 19 there is already a measurement with 2 detected echoes – at 64 and 130 cm.

	value	X	0	1	2	3	4
Static RX_GAIN_code	33	DELTA_GAIN_x	30	-50	0	60	40
DYN_GAIN_start	10	DTx	8	8	10	8	12

Figure 20. Example (2) of Setting the Threshold Curve

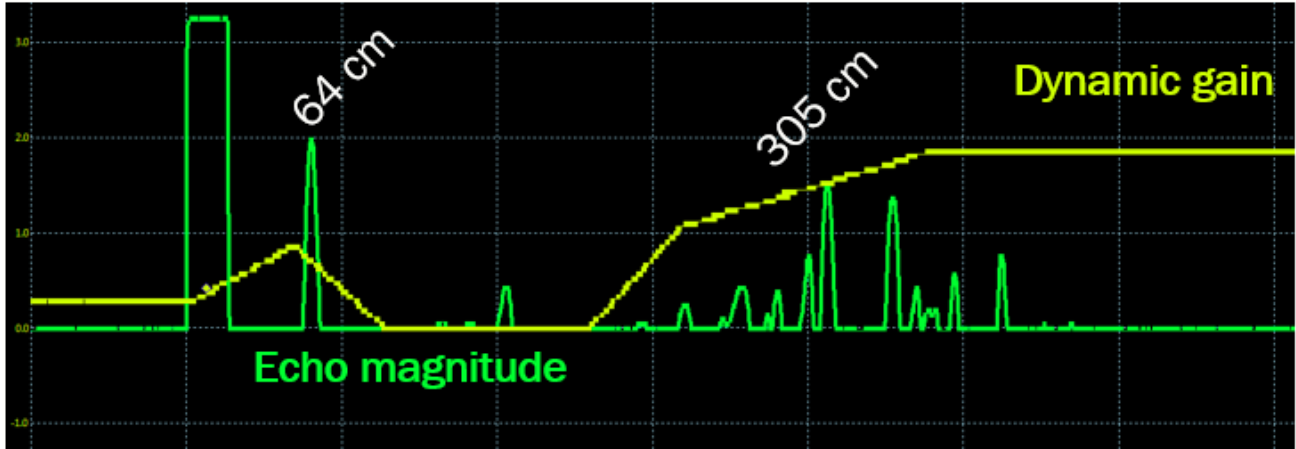

Figure 21.

In Figure 20 you can find example of setting the gain curve and in Figure 21 there is already a real measurement with only 1 detected echo – at 64 cm. Echo at 305 cm is below the threshold.

If you compare real measurements in Figures 19 and 21, you can find how much the signals differ – if the gain curve

is set to low values (Figure 21), then you may miss the real obstacle. On the other hand if the gain curve is set to rather high values (Figure 19), then you may also get the noise (for instance gravel) as the valid echo. Remember that signal should be set within dynamic range of digital processing.

onsemi, **Onsemi**, and other names, marks, and brands are registered and/or common law trademarks of Semiconductor Components Industries, LLC dba "**onsemi**" or its affiliates and/or subsidiaries in the United States and/or other countries. **onsemi** owns the rights to a number of patents, trademarks, copyrights, trade secrets, and other intellectual property. A listing of **onsemi**'s product/patent coverage may be accessed at www.onsemi.com/site/pdf/Patent-Marking.pdf. **onsemi** is an Equal Opportunity/Affirmative Action Employer. This literature is subject to all applicable copyright laws and is not for resale in any manner.

The evaluation board/kit (research and development board/kit) (hereinafter the "board") is not a finished product and is not available for sale to consumers. The board is only intended for research, development, demonstration and evaluation purposes and will only be used in laboratory/development areas by persons with an engineering/technical training and familiar with the risks associated with handling electrical/mechanical components, systems and subsystems. This person assumes full responsibility/liability for proper and safe handling. Any other use, resale or redistribution for any other purpose is strictly prohibited.

THE BOARD IS PROVIDED BY ONSEMI TO YOU "AS IS" AND WITHOUT ANY REPRESENTATIONS OR WARRANTIES WHATSOEVER. WITHOUT LIMITING THE FOREGOING, ONSEMI (AND ITS LICENSORS/SUPPLIERS) HEREBY DISCLAIMS ANY AND ALL REPRESENTATIONS AND WARRANTIES IN RELATION TO THE BOARD, ANY MODIFICATIONS, OR THIS AGREEMENT, WHETHER EXPRESS, IMPLIED, STATUTORY OR OTHERWISE, INCLUDING WITHOUT LIMITATION ANY AND ALL REPRESENTATIONS AND WARRANTIES OF MERCHANTABILITY, FITNESS FOR A PARTICULAR PURPOSE, TITLE, NON-INFRINGEMENT, AND THOSE ARISING FROM A COURSE OF DEALING, TRADE USAGE, TRADE CUSTOM OR TRADE PRACTICE.

onsemi reserves the right to make changes without further notice to any board.

You are responsible for determining whether the board will be suitable for your intended use or application or will achieve your intended results. Prior to using or distributing any systems that have been evaluated, designed or tested using the board, you agree to test and validate your design to confirm the functionality for your application. Any technical, applications or design information or advice, quality characterization, reliability data or other services provided by **onsemi** shall not constitute any representation or warranty by **onsemi**, and no additional obligations or liabilities shall arise from **onsemi** having provided such information or services.

onsemi products including the boards are not designed, intended, or authorized for use in life support systems, or any FDA Class 3 medical devices or medical devices with a similar or equivalent classification in a foreign jurisdiction, or any devices intended for implantation in the human body. You agree to indemnify, defend and hold harmless **onsemi**, its directors, officers, employees, representatives, agents, subsidiaries, affiliates, distributors, and assigns, against any and all liabilities, losses, costs, damages, judgments, and expenses, arising out of any claim, demand, investigation, lawsuit, regulatory action or cause of action arising out of or associated with any unauthorized use, even if such claim alleges that **onsemi** was negligent regarding the design or manufacture of any products and/or the board.

This evaluation board/kit does not fall within the scope of the European Union directives regarding electromagnetic compatibility, restricted substances (RoHS), recycling (WEEE), FCC, CE or UL, and may not meet the technical requirements of these or other related directives.

FCC WARNING – This evaluation board/kit is intended for use for engineering development, demonstration, or evaluation purposes only and is not considered by **onsemi** to be a finished end product fit for general consumer use. It may generate, use, or radiate radio frequency energy and has not been tested for compliance with the limits of computing devices pursuant to part 15 of FCC rules, which are designed to provide reasonable protection against radio frequency interference. Operation of this equipment may cause interference with radio communications, in which case the user shall be responsible, at its expense, to take whatever measures may be required to correct this interference.

onsemi does not convey any license under its patent rights nor the rights of others.

LIMITATIONS OF LIABILITY: **onsemi** shall not be liable for any special, consequential, incidental, indirect or punitive damages, including, but not limited to the costs of requalification, delay, loss of profits or goodwill, arising out of or in connection with the board, even if **onsemi** is advised of the possibility of such damages. In no event shall **onsemi**'s aggregate liability from any obligation arising out of or in connection with the board, under any theory of liability, exceed the purchase price paid for the board, if any.

The board is provided to you subject to the license and other terms per **onsemi**'s standard terms and conditions of sale. For more information and documentation, please visit www.onsemi.com.

ADDITIONAL INFORMATION

TECHNICAL PUBLICATIONS:

Technical Library: www.onsemi.com/design/resources/technical-documentation
onsemi Website: www.onsemi.com

ONLINE SUPPORT: www.onsemi.com/support

For additional information, please contact your local Sales Representative at www.onsemi.com/support/sales