

Ultra High Density and Efficiency 300 W Totempole PFC and HF CM LLC HB Design with 650 V Integrated GaN HEMT

EVBUM2886

Description

The evaluation board user's manual provides basic information about the NCP5892x 650 V Integrated Driver GaN based 300 W Notebook Adapter. It is designed as universal power supply for wide range AC while its PFC front stage utilizes NCP1680, the industry first CrM Totem-Pole PFC mixed signal controller. NCP1680 is providing PWM signals to efficiently drive PFC stage while ensures high power factor and low THD. Totem-Pole PFC Power Stage is based on the NCP58921 which operates in so-called fast-leg portion of the power stage. The NCP58921 is a powerful combination of the Si driver and power GaN HEMT switch provides superior performance compared to monolithic GaN power modules. The NCP5892x integrated implementation significantly reduces circuit and package parasitics while enables more compact design. The NCP58921 integrates a high-performance, high frequency, driver and a 650 V, 50 mΩ Gallium-Nitride (GaN) High Electron Mobility Transistors (HEMT) in a single switch structure while NCP58920 is very similar device that integrates 650 V, 150 mΩ GaN HEMT. Adapter also consist of DC/DC insulate stage that provide safety insulation and regulation of output voltage DC/DC or LLC stage operates at 500 kHz switching frequency while nominal load is applied. Power stage is managed by the NCP13994 high performance current mode LLC controller. Secondary side of LLC Stage utilizes Synchronous rectifier Driver NCP4306. SR Stage is composed of two units of NCP4306 and two paralleled 60 V power MOSFETs for each branch. SR MOSFETs and controllers are implemented on the dedicated SR MODULE daughter card to ease main power board PCB design and to achieve maximum efficiency. To gather more information about particular devices, please refer literature section where useful links for following devices can be found NCP58921, NCP58920, NCP1680, NCP13994, NCP4306, NCP51530 and NC5183.

Basic Parameters

- Compact low-profile design: 134 mm x 62 mm x 18 mm
- Ultra High Density: >36 W/ inch³ including line socket
- Max output power: over 330 W
- Modular design allows flexibility for power scaling or enhancing
- True bridge-less Totem-pole PFC stage operating in CrM
- Implements Single Channel Driver GaN Switches
- Multiple protection features
- Small size with compact design based on simple 2-layers PCBs
- Robust production ready reference design

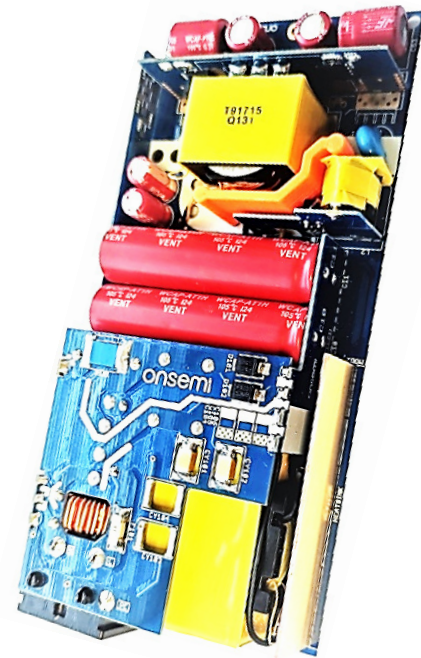

Board Photo

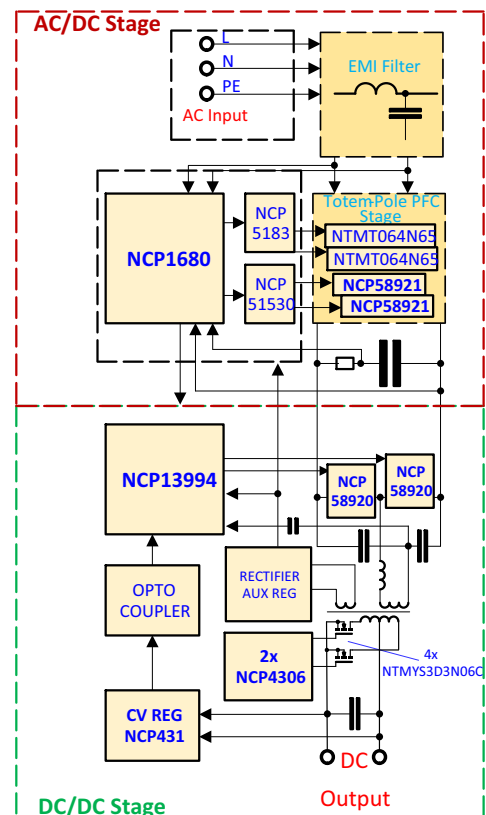

Figure 1. Principle Block Diagram

Modular Conceptions

The demo-board is constructed using a modular system that composes from the MAIN BOARD and several daughter-card modules. Refer to Figure 2 for better understanding of assembly approach. Following daughter-cards are inserted into MAIN BOARD:

- EMI Filter (6)
- CBULK Module (1)
- IMS HB Module (5)
- And SR Module (3)

Modular concept brings several advantages as versatility, possibility to test own daughter cards, easy design update,

opportunity for checking functionality separated module and spare room for additional features. These allow the user to enhance experimenting with daughter-cards. Used type of construction helps to reduce PCB area, thus increases power density, and allows reducing number of PCB layers needed. Almost all PCBs (except to IMS HB Module) are designed as 2-layers with 70 μm copper plating for better thermal management. Also, the 70 μm copper helps to reduce conduction losses especially at secondary side which carries relatively high output current.

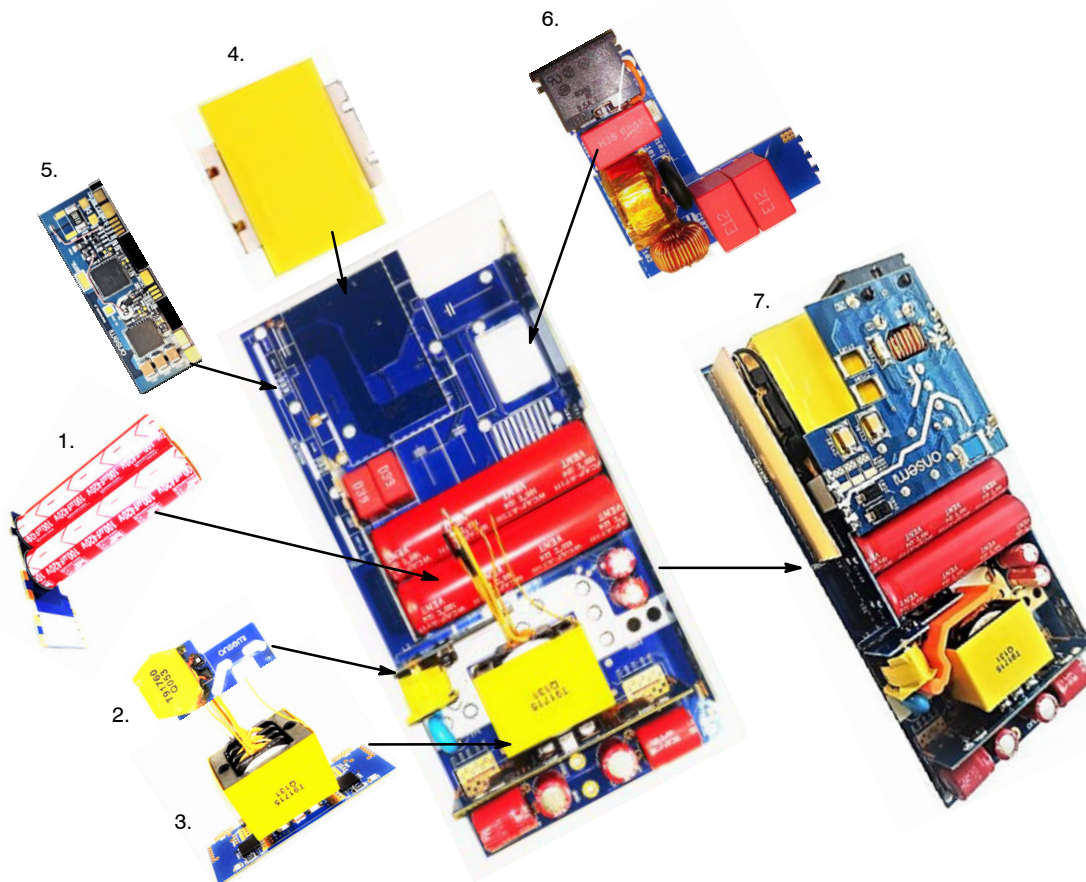

Figure 2. Demo-Board Assembly Principle

SCHEMATIC DIAGRAM DESCRIPTION

The EMI Filter Module

This module consists of several components which are described further. Refer to schematic diagram in Figure 3. First component that's guarding system against high over-current events is fuse F101. The common-mode power line choke L101 reduce common mode noise in low-middle frequency band and higher frequency band is implemented differential inductor. L102. L101 has implemented shielding to avoid noise coupling from PFC stage. The differential EMI noise in lower frequency region

is limited by differential capacitor built from C101, C102 and C103. Two Y-capacitors CY101 and CY102 are intended to minimize the common-mode noise. Additional common mode ceramic capacitor CY1 is located on Mainboard and usually closes power leakage loop between primary and secondary side. The input terminal PE is connected to output ground terminal, however, there is an option to disconnect it. EMI Filter Module is implementing varistor that protect power stage against surge events. Additionally, EMI Filter Module was embedded with inrush bypass diodes that protects fast-leg devices against high inrush current related losses or overheating.

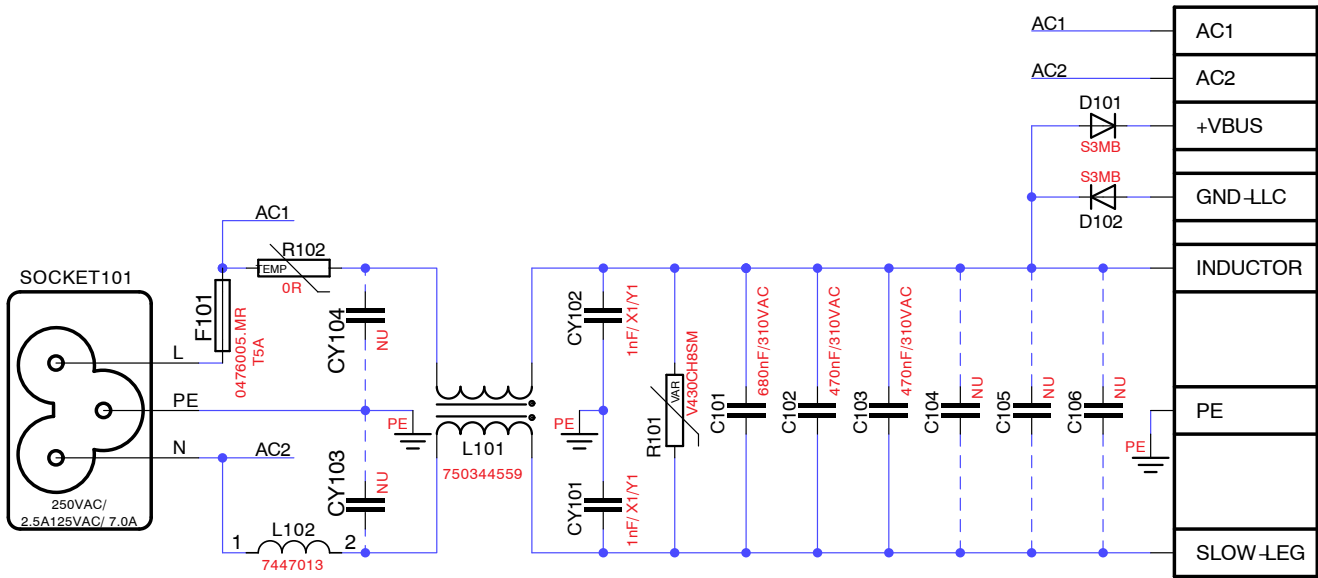

Figure 3. Input EMI Filter Module Schematic Diagram

Totem-Pole PFC Stage

The Totem-pole PFC Front Stage is schematically depicted in following figures: Figure 4, Figure 5, Figure 6 and Figure 7. Figure 4 shows schematic diagram of NCP1680 and surrounding circuitries. NCP1680 the TP PFC Controller operates in Discontinuous Conduction Mode (DCM) and Critical conduction Mode (CrM) and modulated PWM Signals according to Input Line Voltage and load conditions. Controller generates signals for Slow-Leg portion which is depicted on Figure 5. Slow-leg is driven with NCP5183 which standard HV HB Driver and power switches which replaces diodes in traditional approach are

64 mΩ / 650 V Super-junction MOSFETs NTMT064N65S3. Another very important portion of Totem-Pole PFC power stage circuit is Fast-leg Module with level shifter, these both are portrayed in Figure 6 and Figure 7. Fast-leg Module contains two Integrated Driver GaN switches NCP58921. PWM signal that is generated by NCP1680 is referred to ground which means that level shifter is required. For that purpose is used NCP51530, 650 V HB Driver with 60 ns matched delays for both channels. Low latency is essential to enable proper valley switching operation in DCM mode.

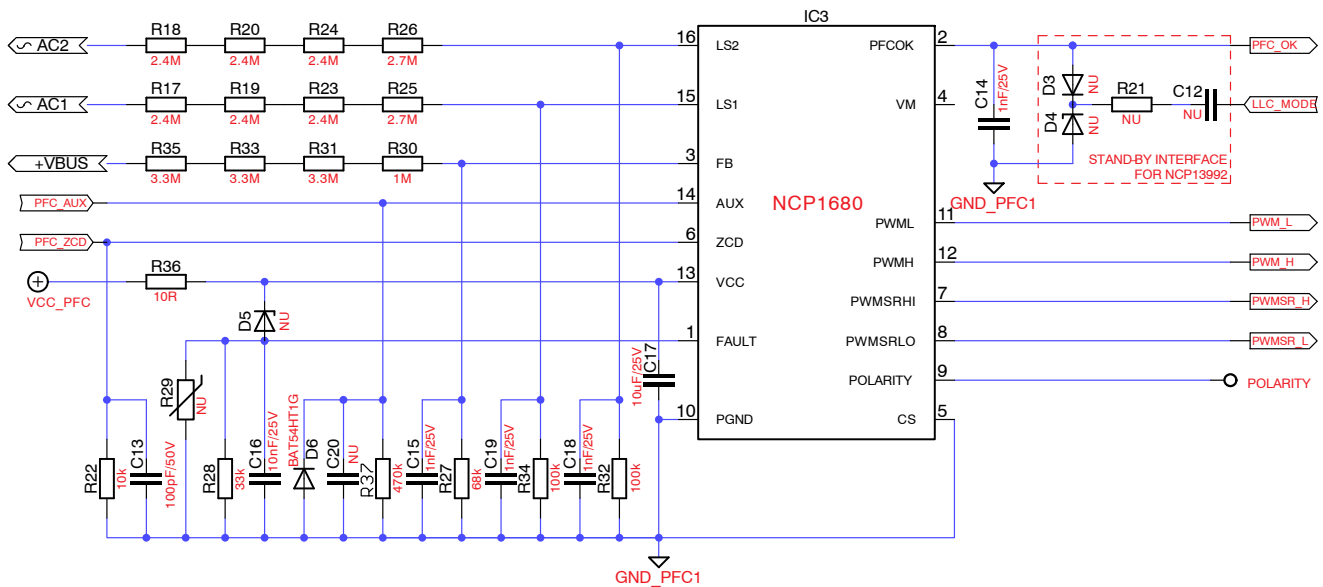

Figure 4. NCP1680 TP PFC Controller Schematic Diagram

EVBUM2886

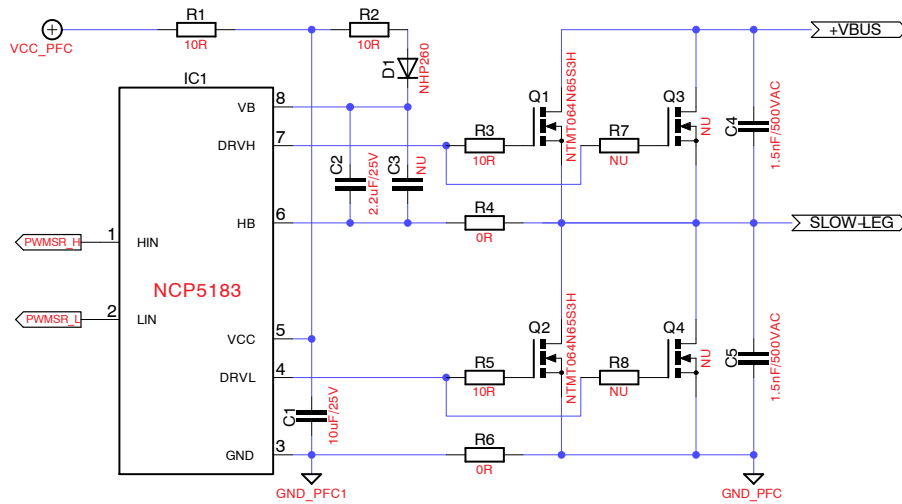

Figure 5. Slow-leg Using NCP5183 HB Driver

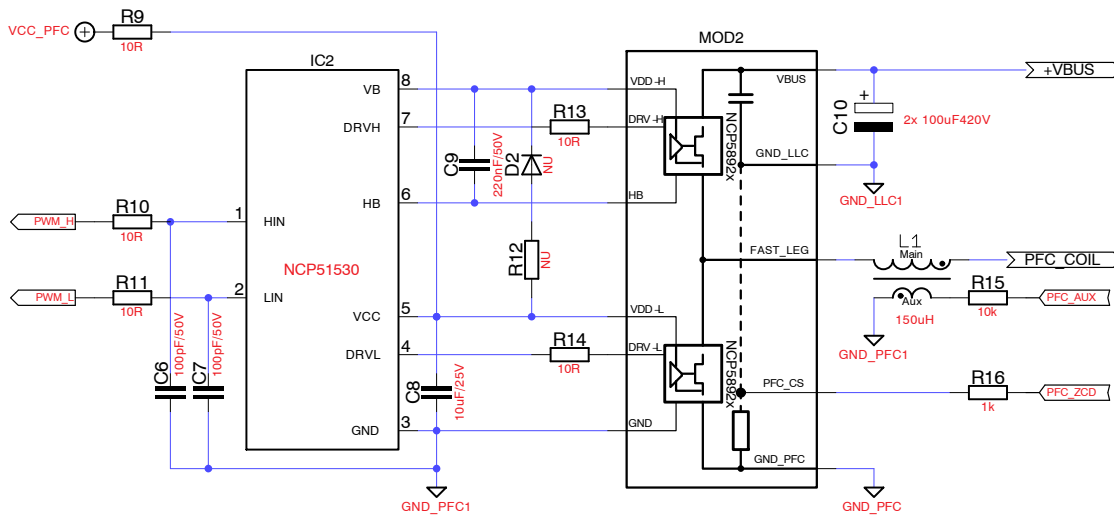

Figure 6. Fast-leg Module with NCP51530 Used as Level Shifter

IMS HB Module

This section refers to schematic diagram depicted in Figure 7 and describes purpose of selected components. IC201 and IC201 are NCP5892x stacked in HB stage. The high-voltage ceramic capacitors C210, C211 & C212 serves as HB stage decoupling and in some sense work as snubber thanks to covering current spikes during transition events. Capacitor C201 is an independent voltage source for bootstrap circuit that helps to reduce impact on C205 and thus minimizes supply noise that might be injected to VDD supply pin of IC202 during bootstrapping of high-side device. R201, R203 R204 and R208 insert impedance that forms low pass filter together with the VDD decoupling capacitors C206 and C207. This limits current spikes in between supply rails of multiple ICs that may occur during transition as result PCB impedance distribution given by PCB layout design. R203, R206, R207 and D201 compose bootstrap path for easier supplying of high-side device. Capacitors C204 and C205 are required for 5 V LDO

regulator decoupling so these are needed for NC58921 despite that regulator output is not loaded. Mentioned capacitors ensure that regulators stay stable and won't oscillate and device consumption remain low. C204 and C205 are not needed for NCP58920. The low pass filters made of RC couples R202–C202 and R205–C203 filter out glitches or noise. C202–203 range may be from 220pF up to 3.3 nF and higher values are required for hard-switched application to attenuate noise that may easier enter inputs as ISM board suffer from higher parasitic capacitance. C208–209 are driver regulator decoupling capacitors that are essential and recommended material is X7R. Resistors R213–R216 impact driver turn-on resistance and this way can adjust device turn-on dv/dt. R211 and R212 are pull-up resistors that keep device in enabled state. R209–R210 are mandatory for NCP58920, and these resistors set high level of Gate Drive Strength (GDS) that is needed for normal operation. For more information about GDS feature refer to NCP58920 datasheet. R215–R218 are 0 Ω and interconnect

EVBUM2886

device ground and power R214–217 are optional resistors that might be used for changing of device grounding especially for higher power. Once R214–217 are assembled (recommended value 0Ω) then the couple R215–R218 must be removed.

Jumper Board

In Figure 8 is depicted jumper board schematic diagram and purpose of this board is very simple, it provides option for connecting output ground to PE terminal using various components in order to offer EMI tweaking options.

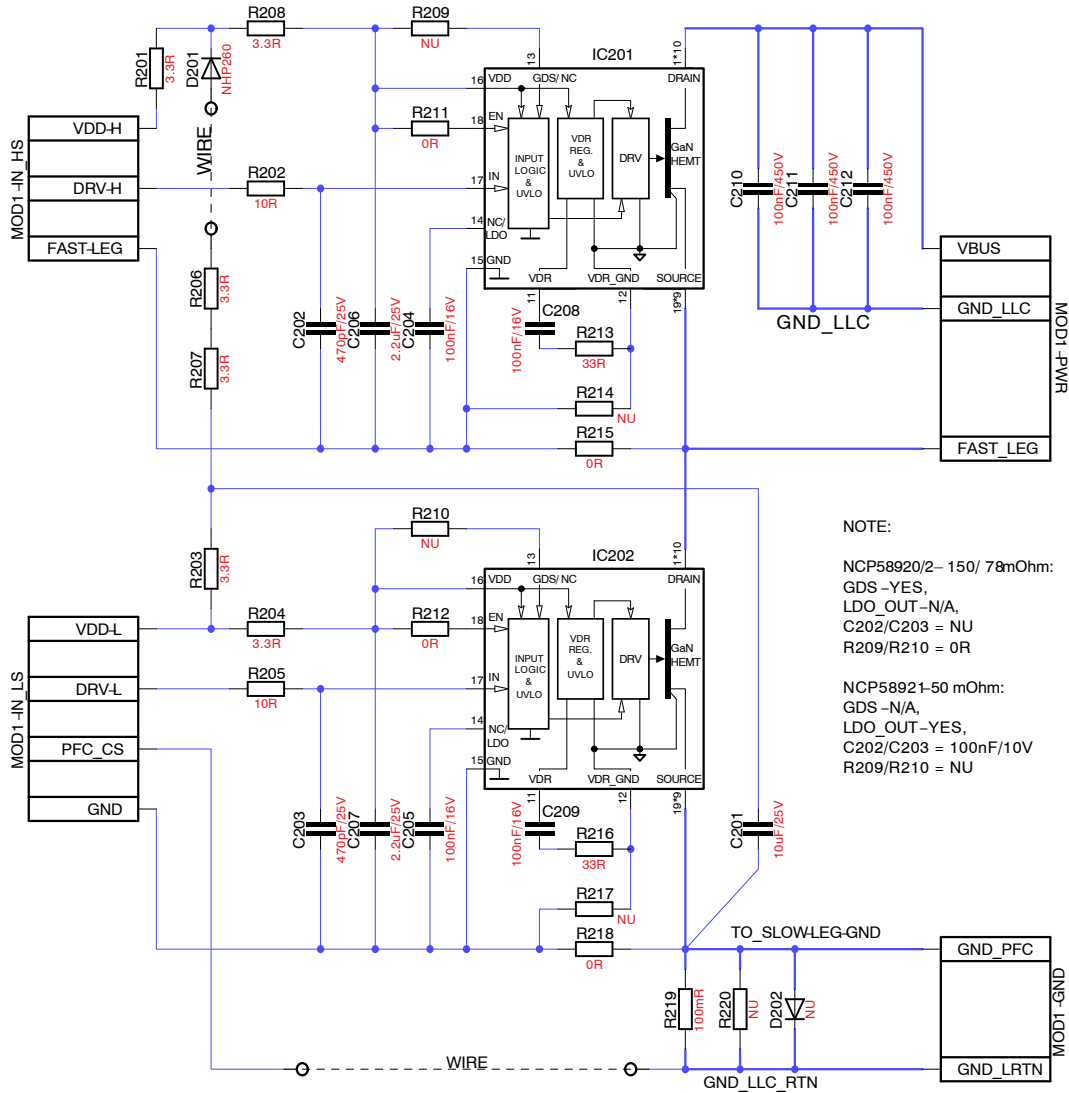

Figure 7. IMS HB Module Schematic Diagram

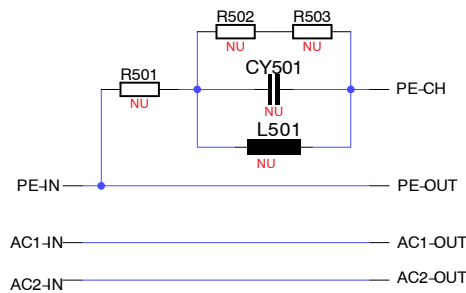

Figure 8. Jumper Board Schematic Diagram

LLC Stage Implementation

In Figure 9, Figure 10 and Figure 11 is displayed schematic diagram of LLC Stage control circuitry, LLC Half-Bridge Power Stage and Secondary Side SR Stage respectively. LLC Stage control circuit is based NCP13994 high performance current mode LLC controller for half bridge resonant converters. The controller implements 600 V gate drivers, simplifying layout and reducing external

component count. NCP13994 senses output voltage via Feedback pin and resonant capacitor voltage and according to load modulates and output PFM signals. NCP13994 directly drives LLC HB Power Stage based on NCP58920 while for high side device utilizes internal level shifter/driver. NCP13994 and LLC stage operates approximately at 460 kHz when full load is applied, this is given by resonant

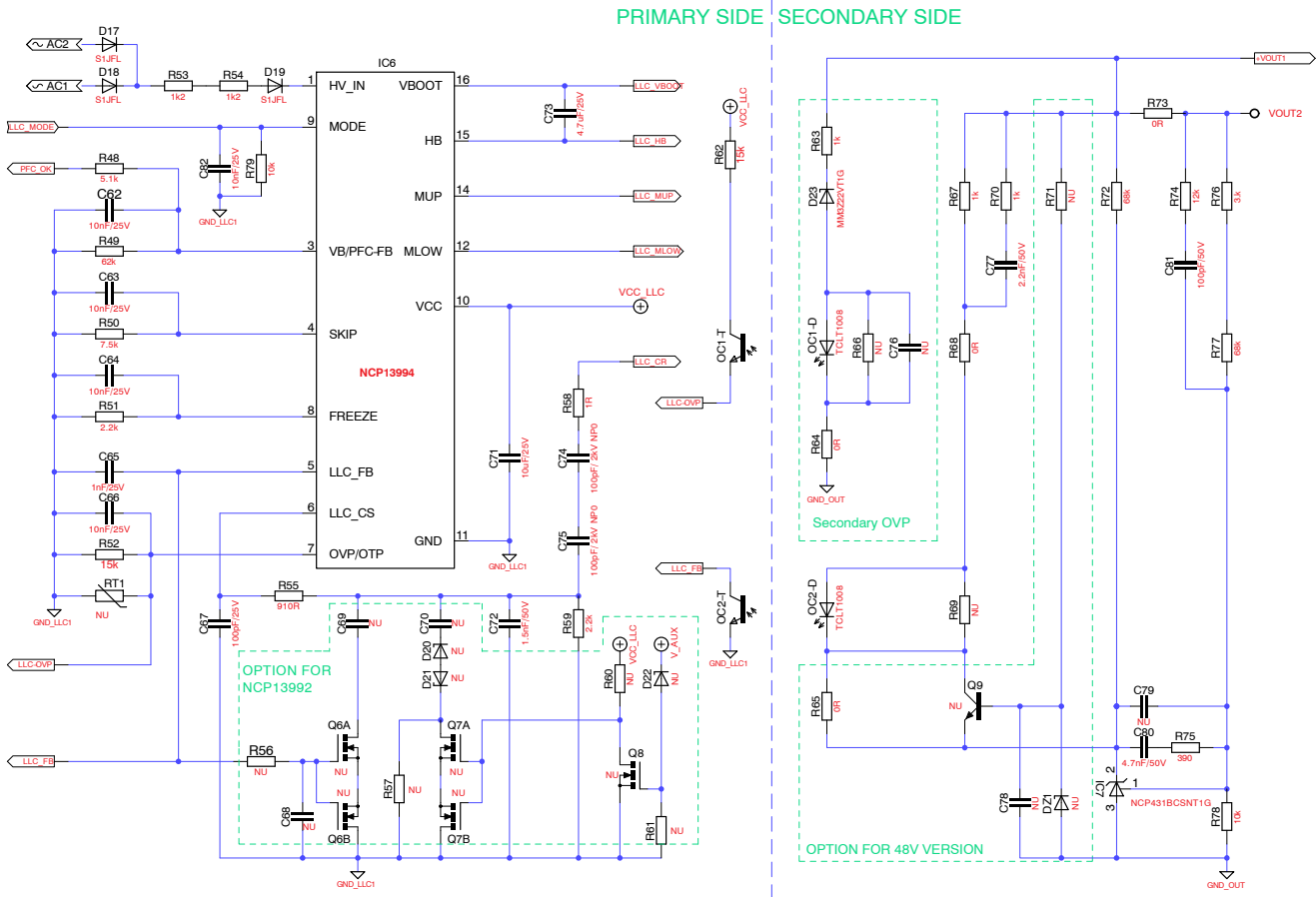
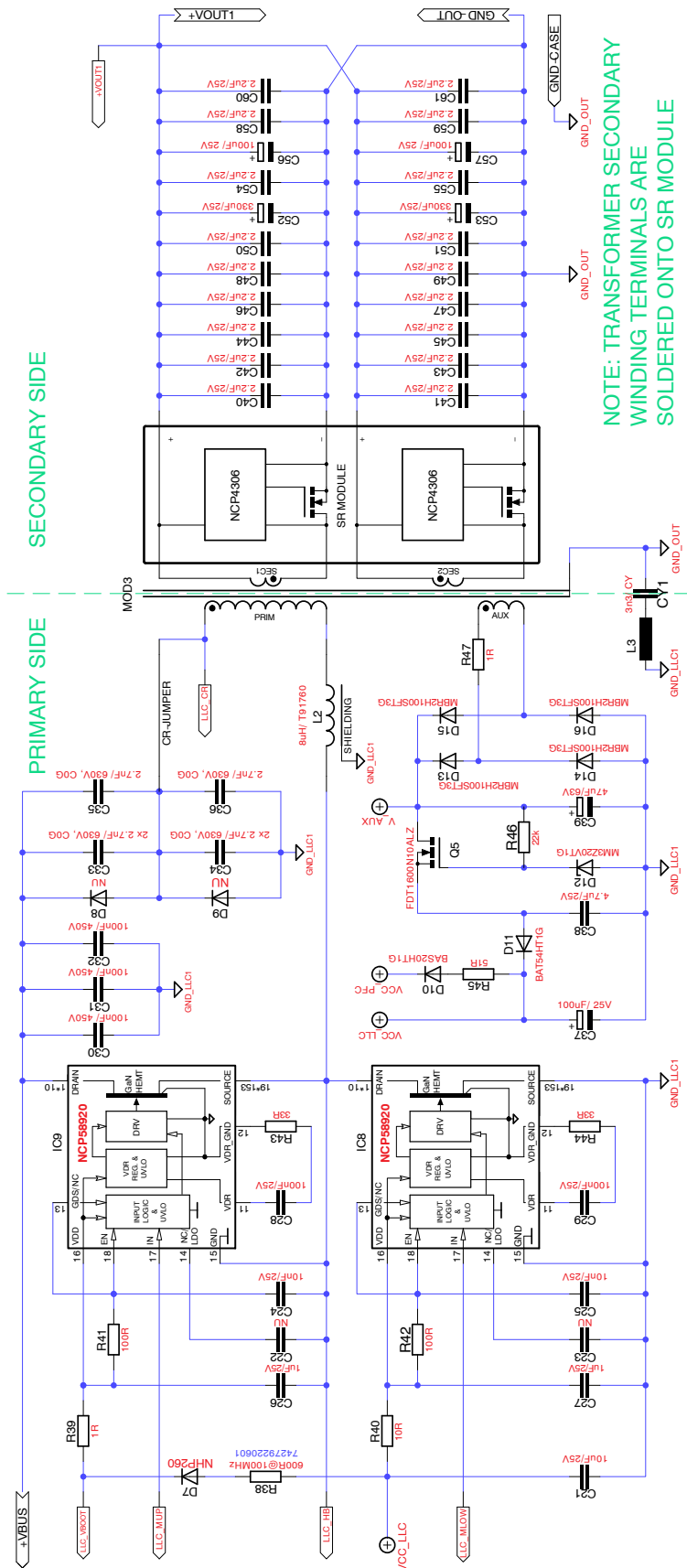

Figure 9. LLC Stage Control Circuitry Based on NCP13994

EVBUM2886



NOTE: TRANSFORMER SECONDARY WINDING TERMINALS ARE SOLDERED ONTO SR MODULE

Figure 10. LLC Half-Bridge Power Stage based on NCP58920

SR Module is portrayed Figure 11. This module is built based on four NTMYS3D3N06CLTWG single channel MOSFETs and two synchronous rectification drivers NCP4306. MOSFETs Q301–304 are packaged in SO–8FL to support high power density. Two MOSFETs are arranged in two branches of center tapped rectifier. Each MOSFET branch is protected against voltage spikes by the RC snubbers which are connected across the FETs drains and sources. RC snubber circuits are composed of C301–R301 and C302–R302. The synchronous rectifier drivers IC301–302 NCP4306 drive MOSFETs based on drain voltage information. Each NCP4306 uses external adjusting and decoupling elements. Module requires high frequency decoupling, which is done with ceramic capacitors C303 and

C304. R304/R305 and R309/R308 set minimum ON–time and minimum OFF–time period respectively. Minimum ON–time is set to ≈ 110 ns and minimum OFF–time was adjusted to ≈ 680 ns. Automatic Light Load detection (LLD) timer can be tuned by R303–R310. The LLD pins must be decoupled with C305–C306. LLD timer was tweaked to 68 μ s which is suitable value for most LLC converters and improves no–load consumption. For more information about LLD feature refer to datasheet of NC4306. Above mentioned timing values well cover SR setup for this reference design in whole operating range. NCP4306 with 5 V driver clamp option is recommended for this design to reduce driving losses.

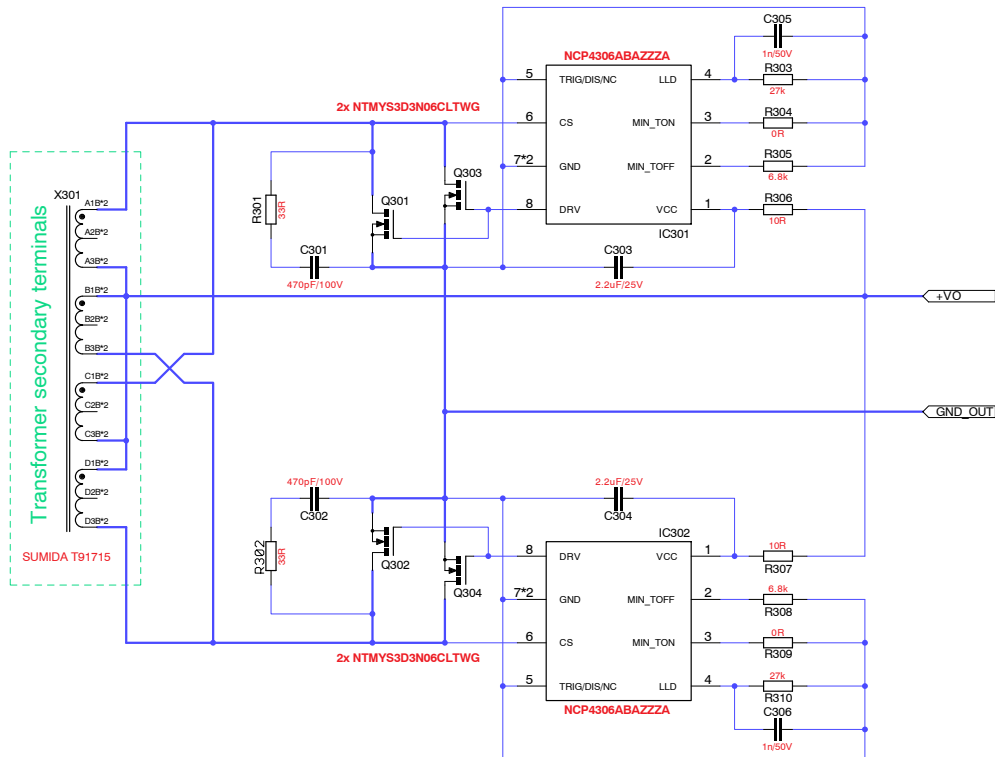

Figure 11. Secondary Side SR Stage Based on NCP4306

DEMO-BOARD POWER-UP AND TEST PROCEDURE

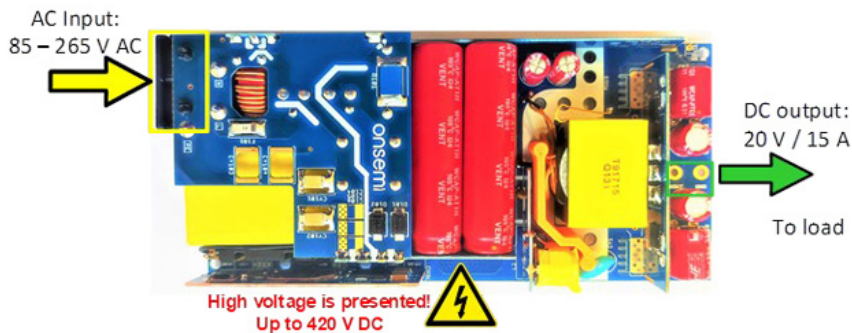

Figure 12. Demo-board Connection to AC Power Supply and DC Load

Important notes:

- Do not apply extreme voltage to the input terminals!
- Be careful, high DC voltage is present!
- Do not apply DC voltage to the input terminals!
- The demo is not optimized for surge, lightning, etc.
- This reference board requires thermal management especially at very low line voltage.
- Use fan for excessive heat spreading.
- Follow up power-up and power-down sequences.
- Second case achieved lower temperature rise and

8. Modify electronic load current to desired level while output voltage is monitored.

Power-down Sequence:

1. Turn AC Supply off.
2. Discharge bulk capacitor for manipulating further.

Measurements section

Table 1 provides summary information about system no-load power consumption measured at several input voltage levels. Figure 13 provides efficiency curves versus output load and two input line voltage levels. Figure 14 shows thermal images whilst full load was applied at 90 V AV at input. Pictures from Figure 15 to Figure 23 are demonstrating operating waveforms, which were captured at specified condition. It should be noted that operating waveforms can vary depending on actual demo-board as well as components values are altering due to their tolerance. PFC Stage waveforms are displayed in Figure 15 and Figure 16. LLC Stage operating waveforms show Figure 17 up to Figure 23. Step load response and output voltage ripple showed from Figure 21 to Figure 22 were measured directly at output terminals without any additional decoupling or filtering. If lower ripple is required simple additional post filter can be implemented to reduce ripple to desired level.

Power-up sequence in debugging mode:

1. Connect AC Supply to the demo-board AC input (Refer to figure above).
2. Connect Electronic Load at the output terminals with proper polarity – see figure below.
3. Set AC Supply voltage to 30 Vrms, set current limit to 5 Arms
4. Turn AC Supply on and check consumption should be very low.
5. Change to AC voltage level to 60 Vrms and then 85 Vrms/ always check input current.
6. Adapter starts approximately at 85 Vrms, check output voltage, approximately 20 V.
7. Change to AC voltage level desired value within range of 85 – 265 Vrms

Table 1. NO-LOAD POWER CONSUMPTION VS. INPUT LINE VOLTAGE LEVEL

Demo-board No-Load Consumption vs. Line				
Line [V rms]	90	110	230	265
Consumption [mW]	131	133	158	164

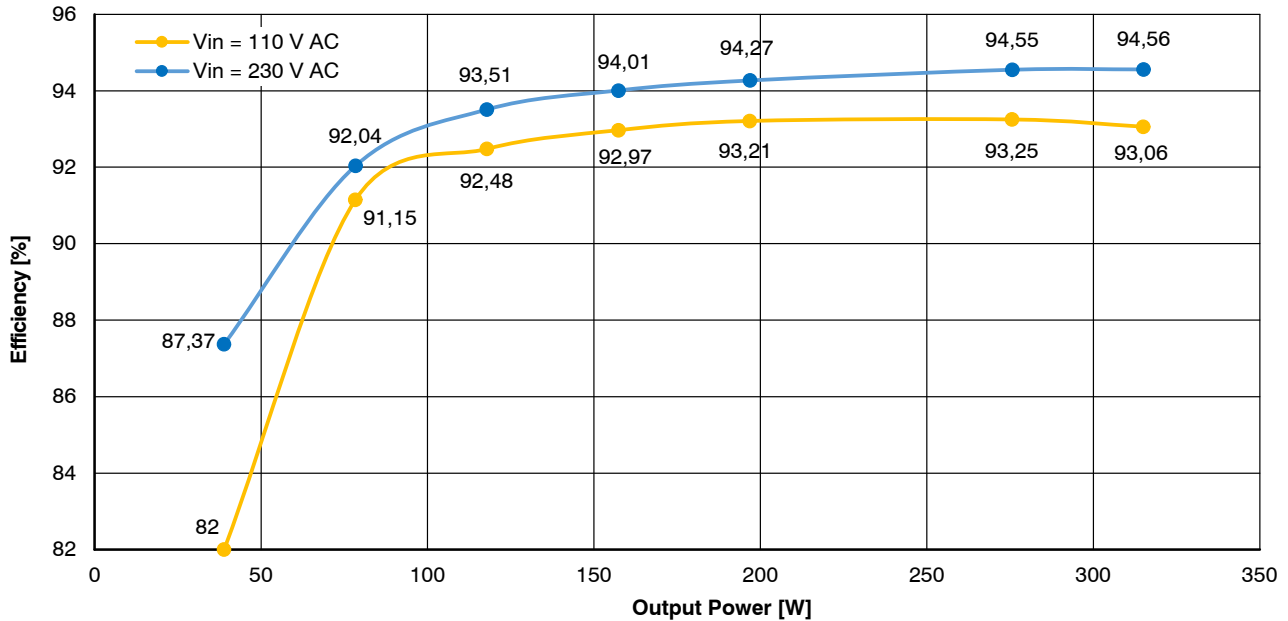
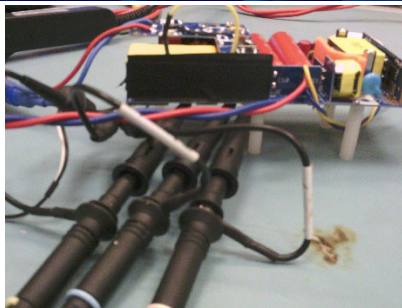
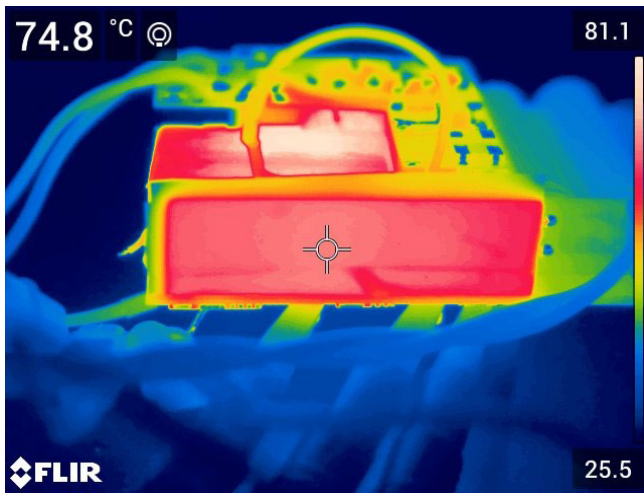
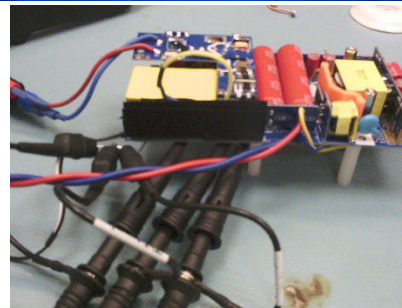
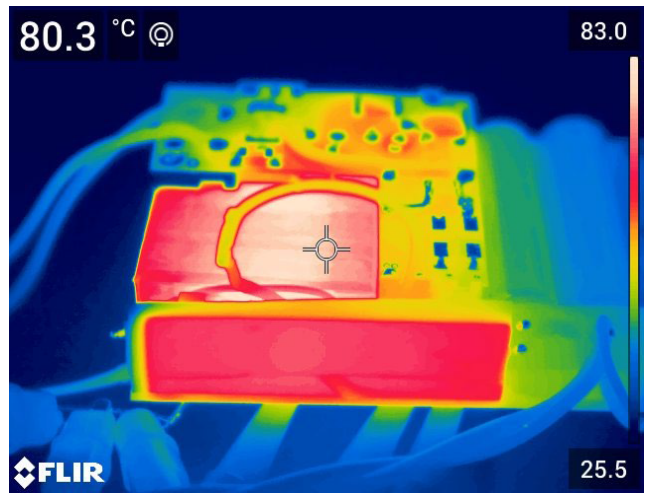

Figure 13. Demo-board Efficiency vs. Load



TP-PFC IMS HB Module Back-side Thermal Image



TP-PFC Inductor magnetic core Thermal Image

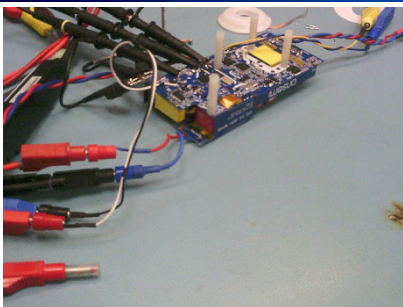
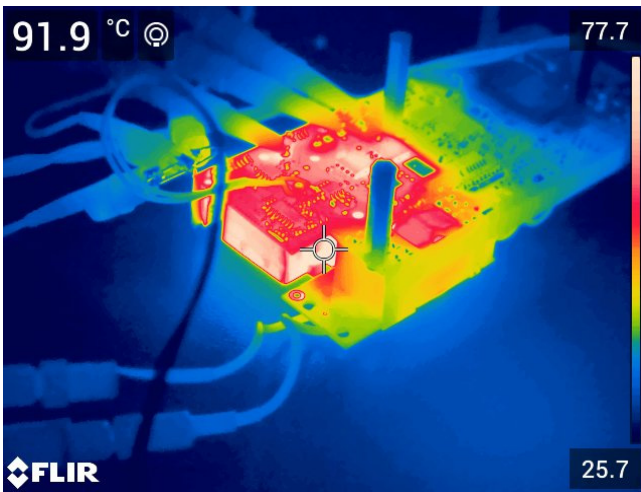

TP-PFC Inductor winding Thermal Image

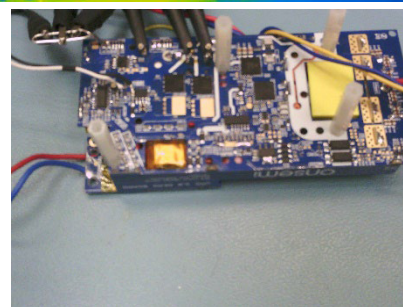

Thermal Image of TP-PFC Slow-leg MOSFET

Figure 14. Demo-board Thermal Images of PFC Stage at 90 V AC and Full-load

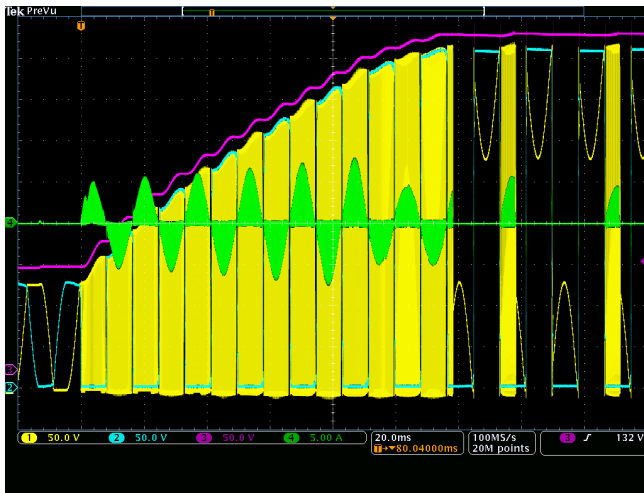

TP PFC Start-up sequence waveform at 90 V RMS and No-Load

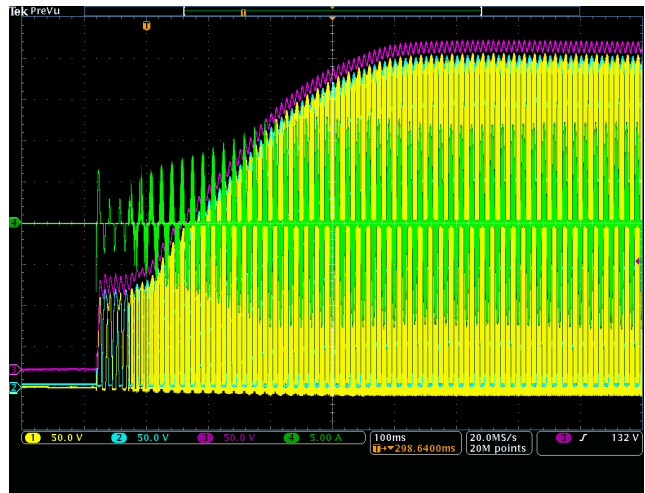

TP PFC Start-up sequence waveform at 90 V RMS and 320 W Load

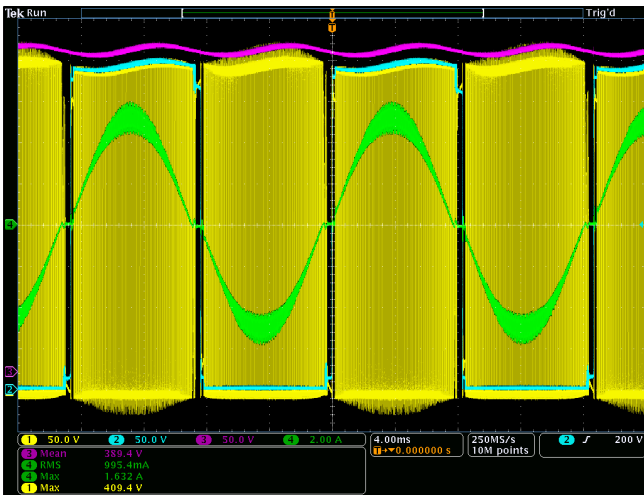

Waveform at 90 V RMS and 300 W Load

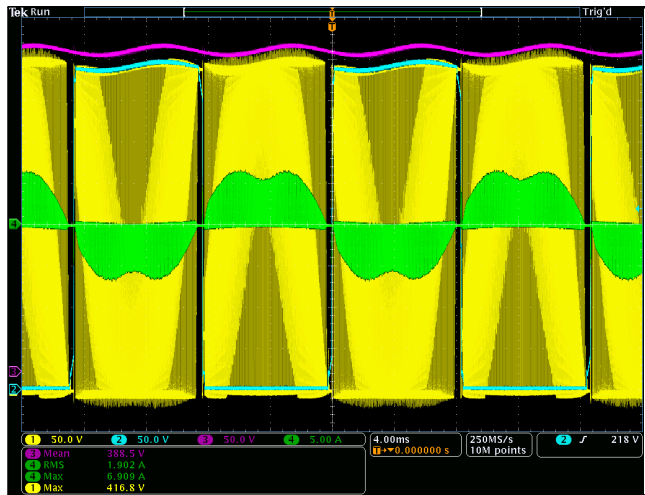

Waveform at 230 V RMS and 300 W Load

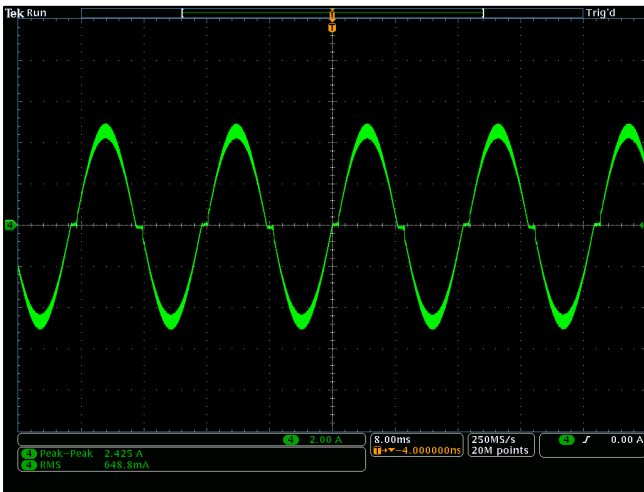

Input current Waveform at 90 V RMS and 320 W Load

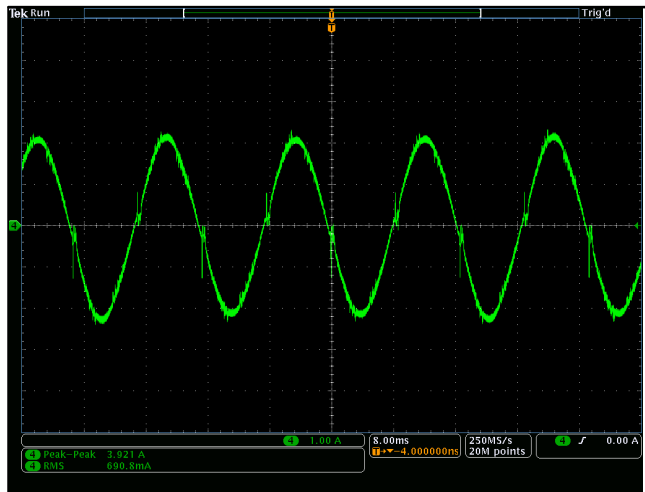

Input current Waveform at 230 V RMS and 320 W Load

— CH1 – HB Fast-leg — CH2 – HB Slow-leg — CH3 – V_{BUS} — CH4 – Input current

Figure 15. Demo-board PFC Stage Application Waveforms

EVBUM2886

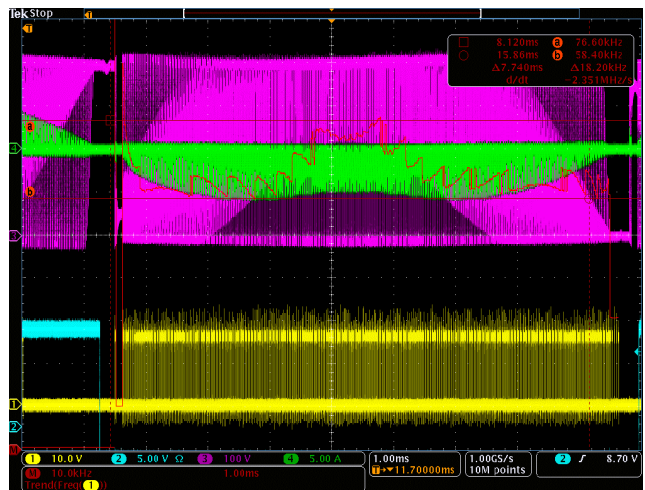
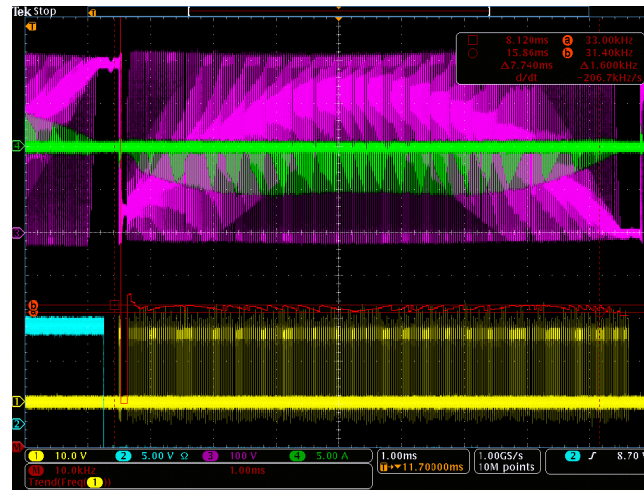
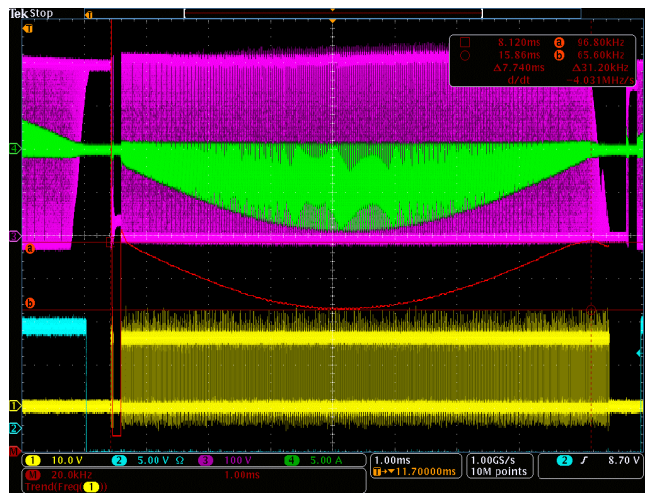
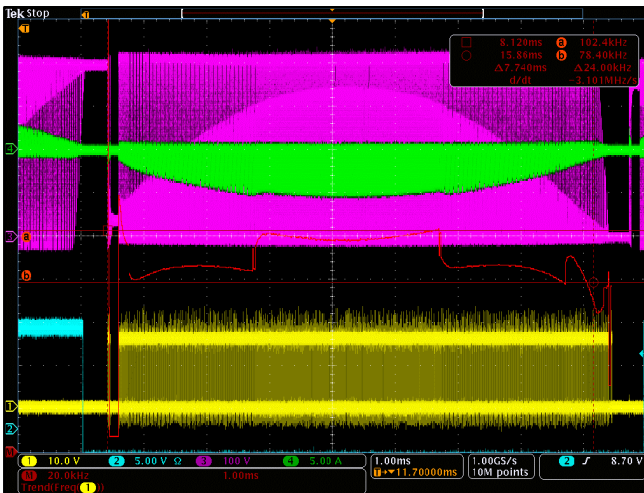
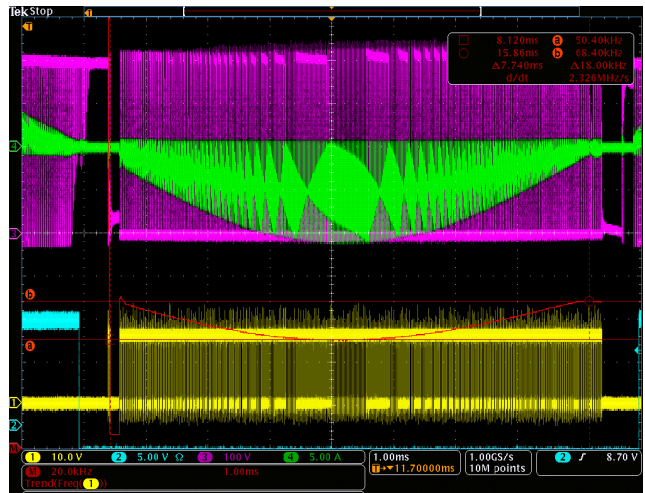
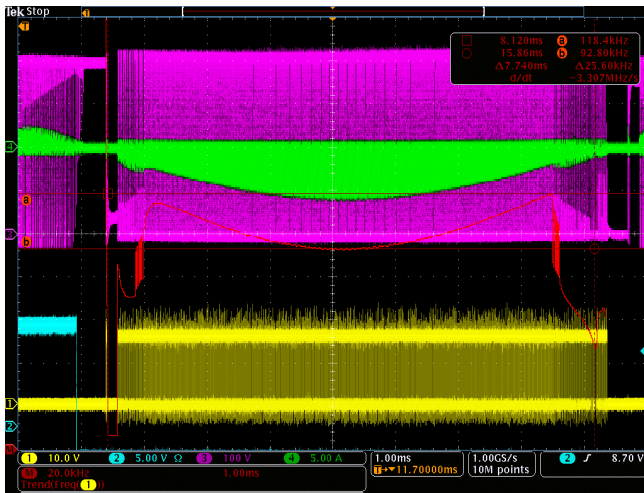

— CH1 - HB Fast-leg — CH2 - HB Slow-leg — CH3 - V_{BUS} — CH4 - Input current — M - Switching Frequency

Figure 16. Demo-board PFC Stage Application Waveforms – Operating Frequency

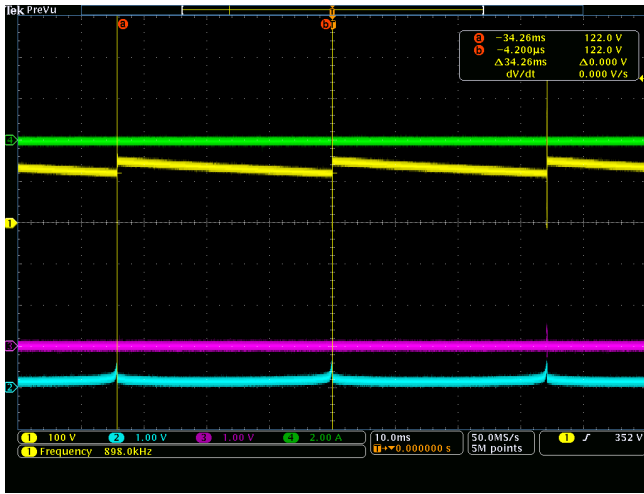

LLC Waveform at No-load – Bursts period

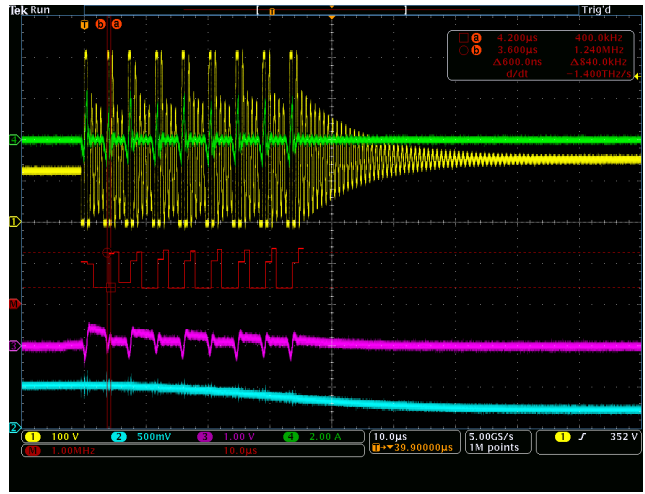

LLC Waveform at No-load – Bursts detail



LLC Waveform at Light-load Mode 2 A Load – Packaging

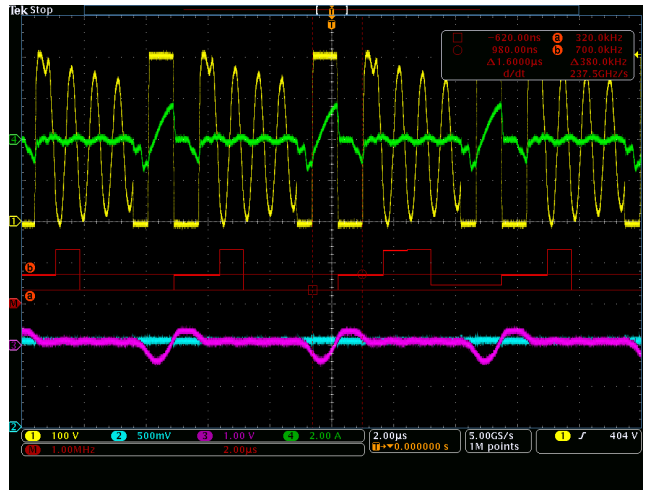

LLC Waveform at Light-load Mode 2 A Load – Package detail

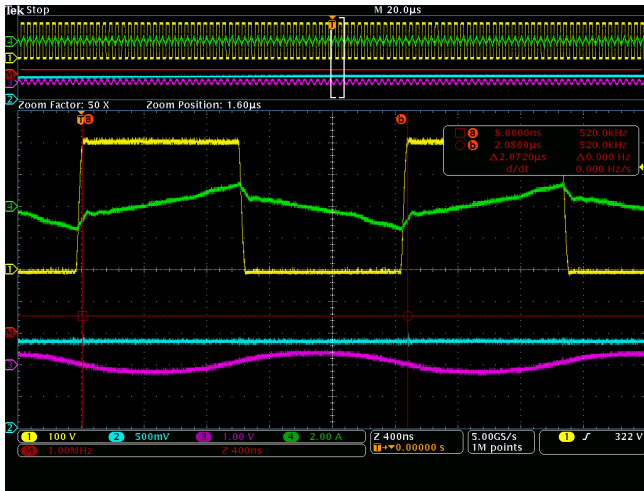

LLC Waveform at Normal Mode 2.5 A Load

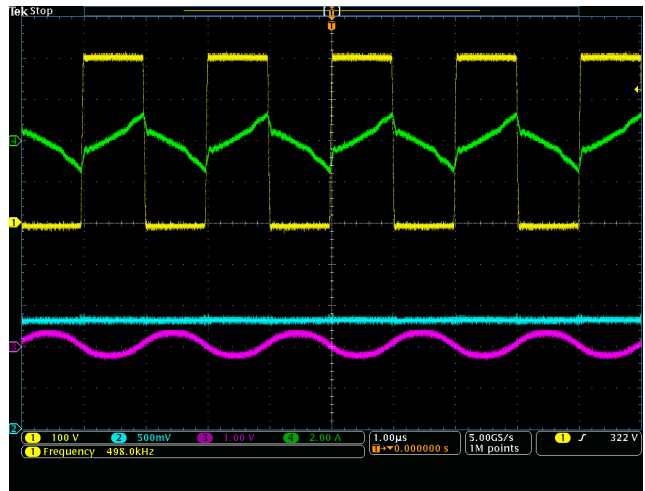

LLC Waveform at Normal Mode 2.5 A Load

— CH1 – HB Fast-leg — CH2 – HB Slow-leg — CH3 – V_{BUS} — CH4 – Input current — M – Switching Frequency

Figure 17. Demo-board LLC Stage Application Waveforms

EVBUM2886

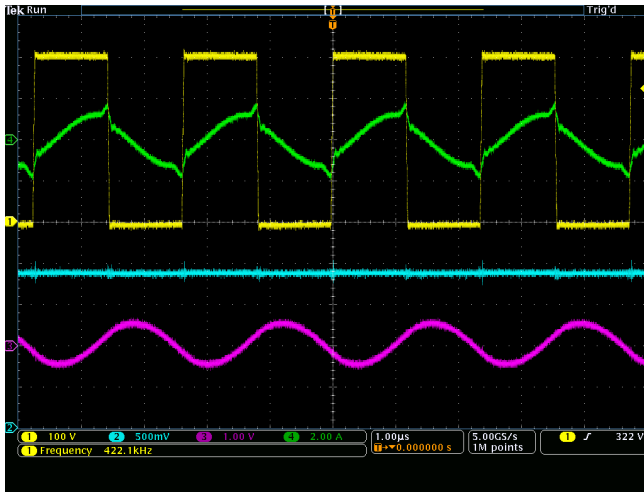

LLC Waveform at Normal Mode 5 A Load

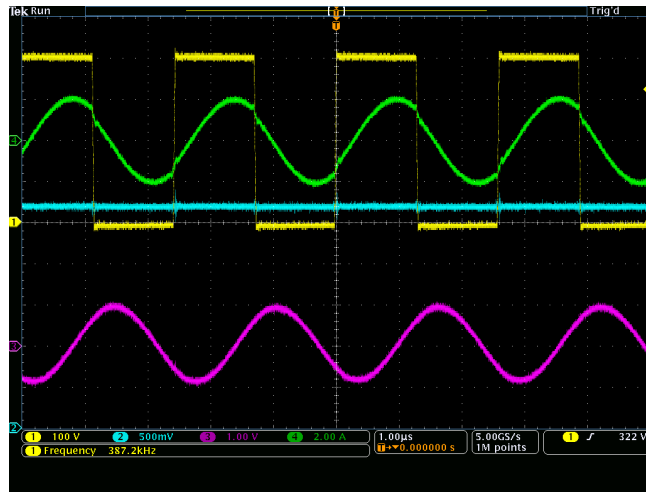

LLC Waveform at Normal Mode 10 A Load

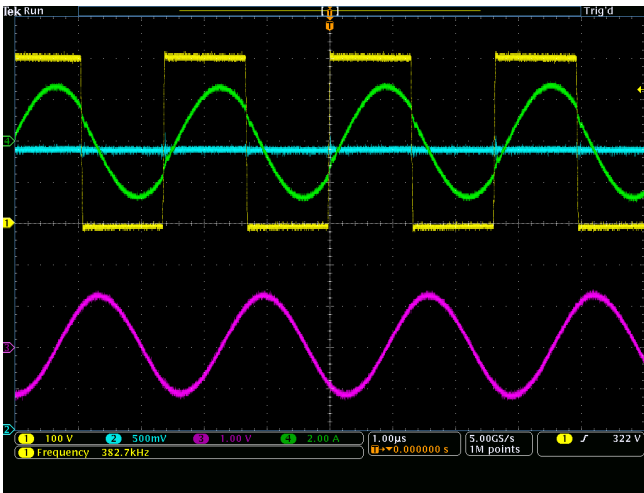

LLC Waveform at Normal Mode 15 A Load

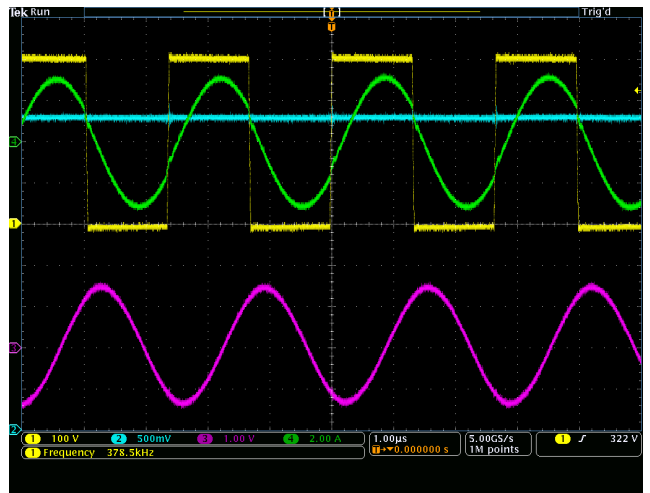

LLC Waveform at Normal Mode 18 A Load

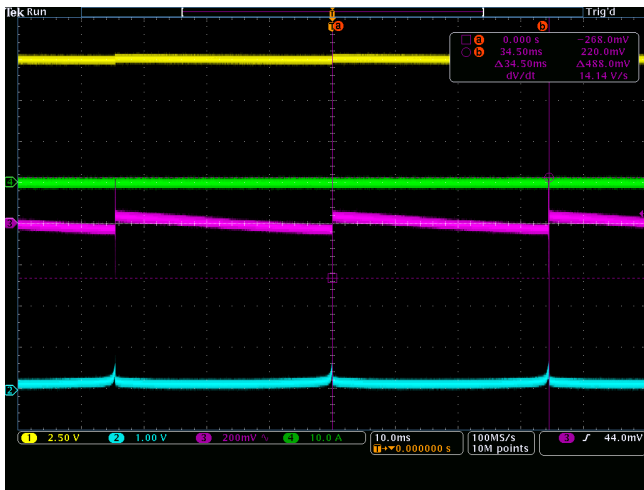

LLC Waveform V_{out} ripple at No-load

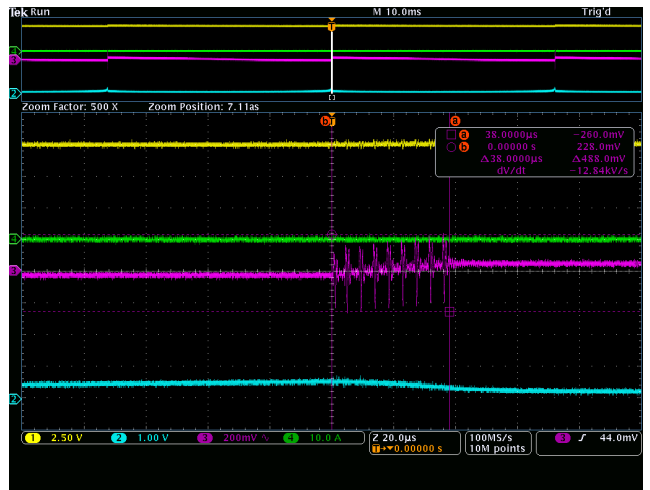

LLC Waveform V_{out} ripple at No-load – Bursts detail

— CH1 – V_{out} DC

— CH2 – LLC FB

— CH3 – V_{out} AC

— CH4 – Output current

Figure 18. Demo-board LLC Stage Application Waveforms

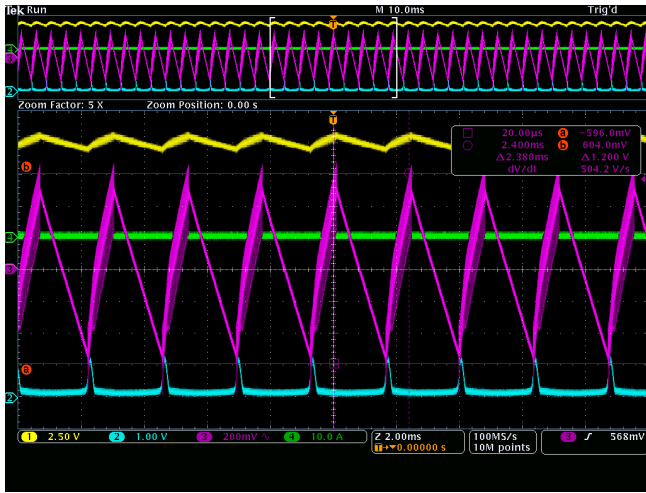

LLC Waveform V_{out} ripple at 0.6 A – worse case ripple

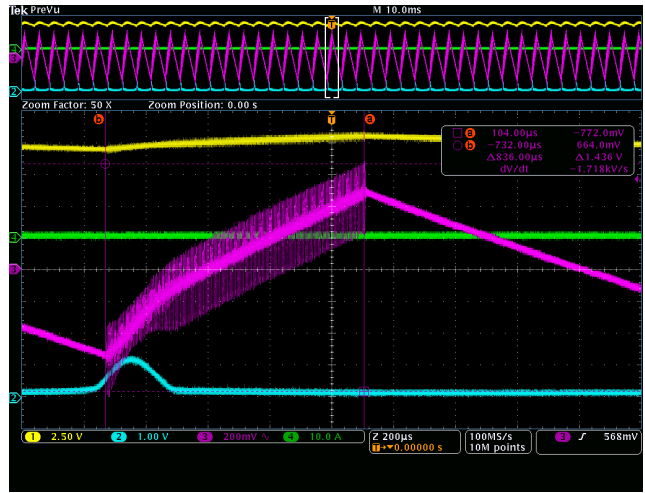

LLC Waveform V_{out} ripple at 0.6 A – burst detail

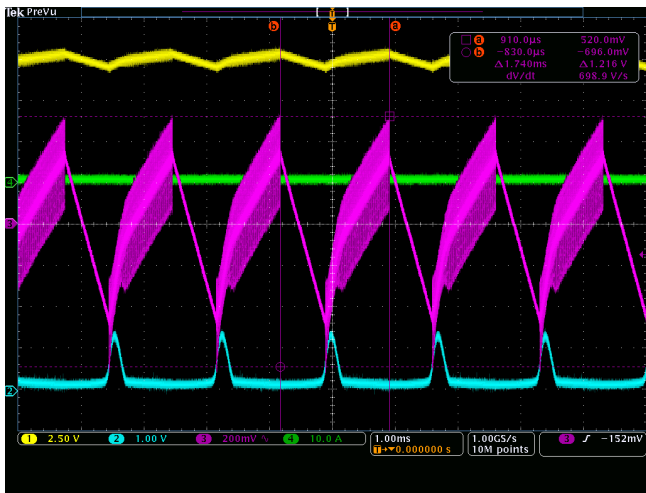

LLC Waveform V_{out} ripple at 1 A

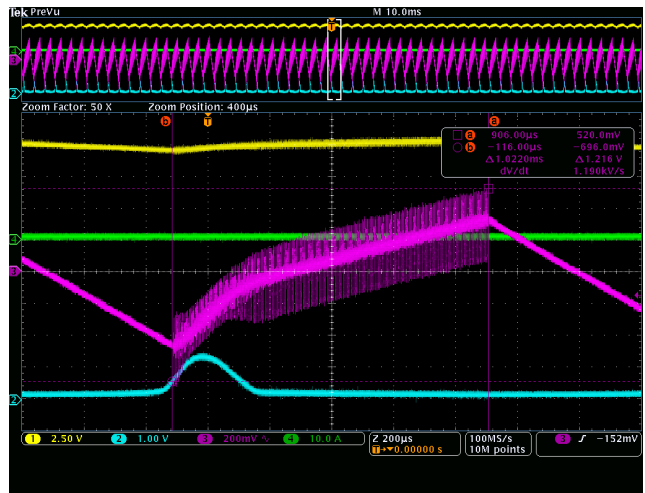

LLC Waveform V_{out} ripple at 1 A – burst detail

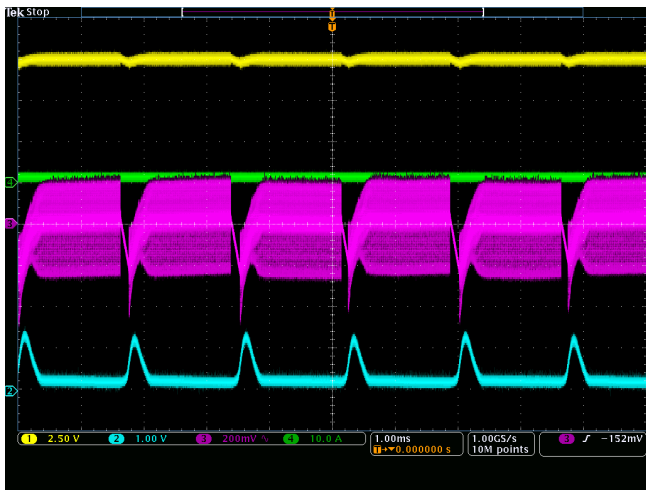

Waveform V_{out} ripple at 1.5 A

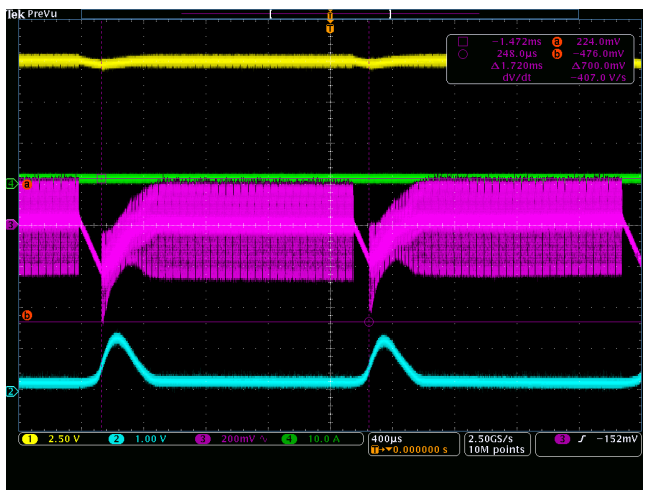

LLC Waveform V_{out} ripple at No-load – bursts detail

— CH1 – V_{out} DC — CH2 – LLC FB — CH3 – V_{out} AC — CH4 – Output current

Figure 19. Demo-board LLC Stage Application Waveforms – Output Ripple

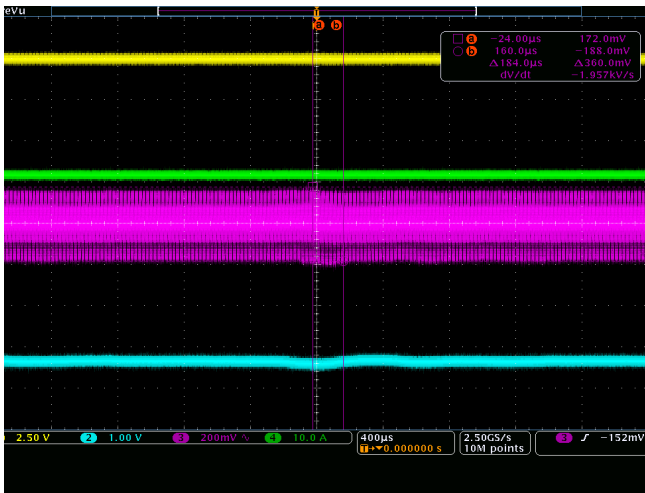

LLC Waveform V_{out} ripple at 1.85 A



LLC Waveform V_{out} ripple at 1.85 A – detail

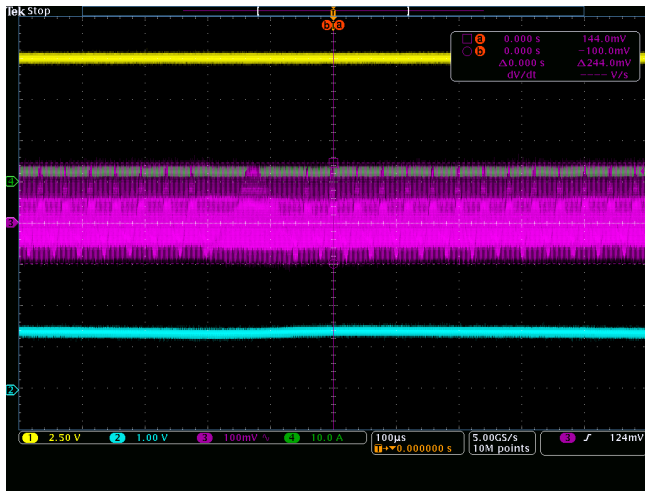

LLC Waveform V_{out} ripple at 2.5 A

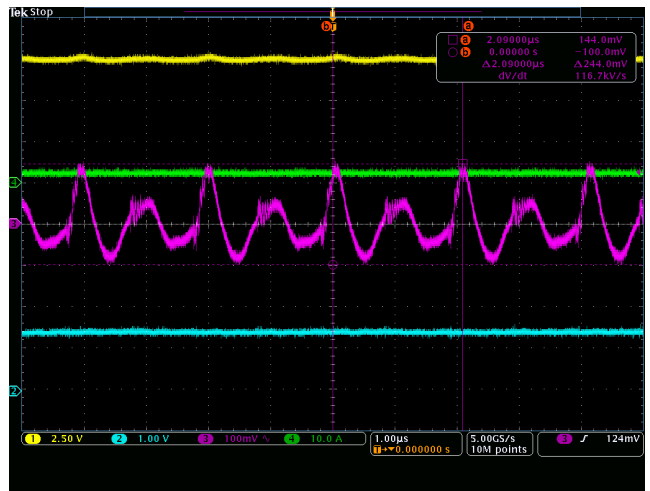

LLC Waveform V_{out} ripple at 2.5 A – detail

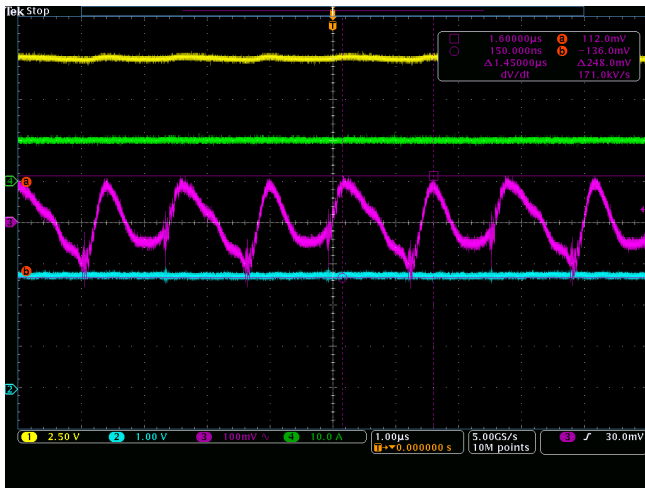

LLC Waveform V_{out} ripple at 10 A

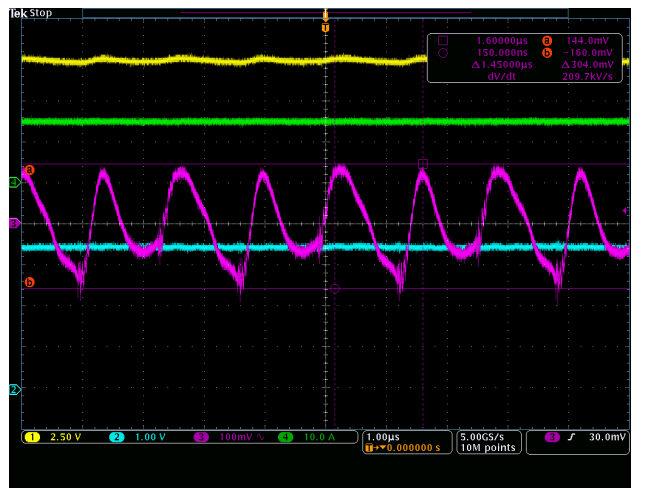

LLC Waveform V_{out} ripple at 15 A

— CH1 – V_{out} DC — CH2 – LLC FB — CH3 – V_{out} AC — CH4 – Output current

Figure 20. Demo-board LLC Stage Application Waveforms – Output Ripple

EVBUM2886

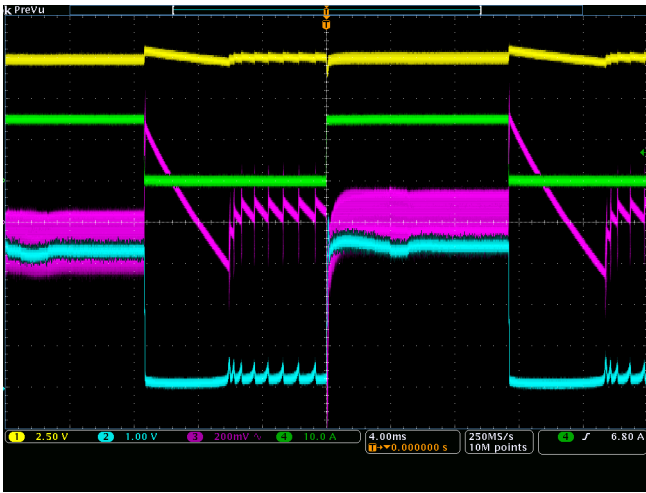

LLC Waveform – Step response 0 → 15 A

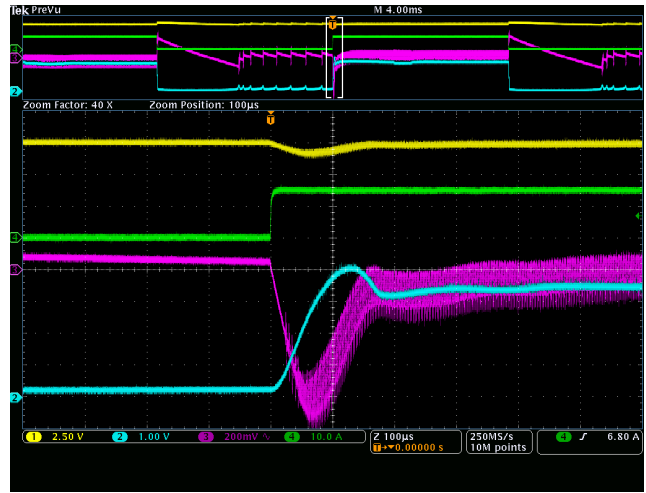

LLC Waveform – Step response 0 → 15 A – detail

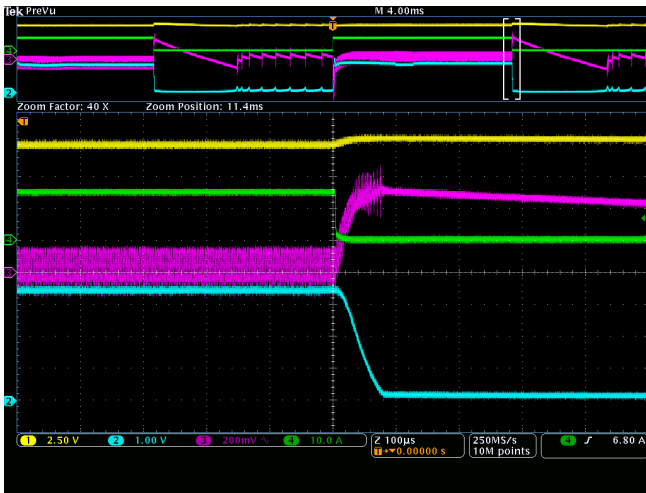

LLC Waveform – Step response 15 → 0 A – detail

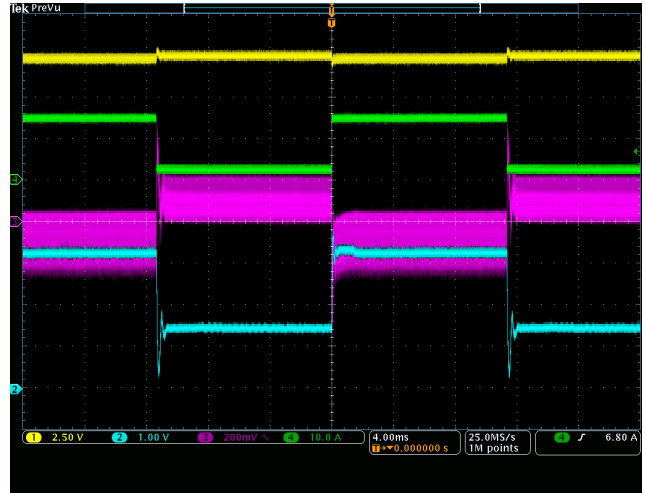

LLC Waveform – Step response 2 A → 15 A

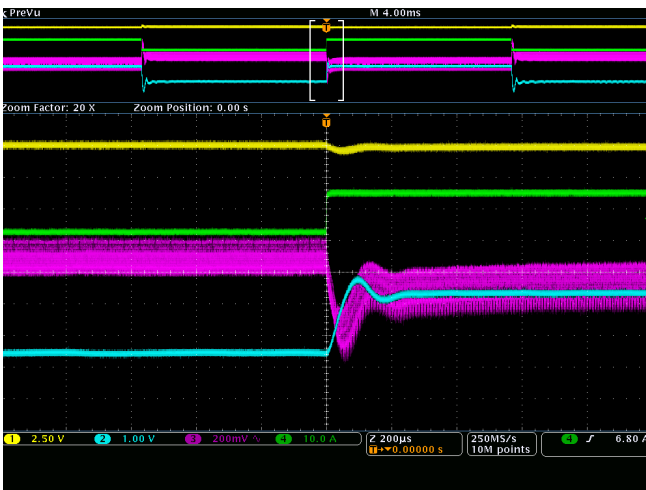

LLC Waveform – Step response 2 A → 15 A – detail

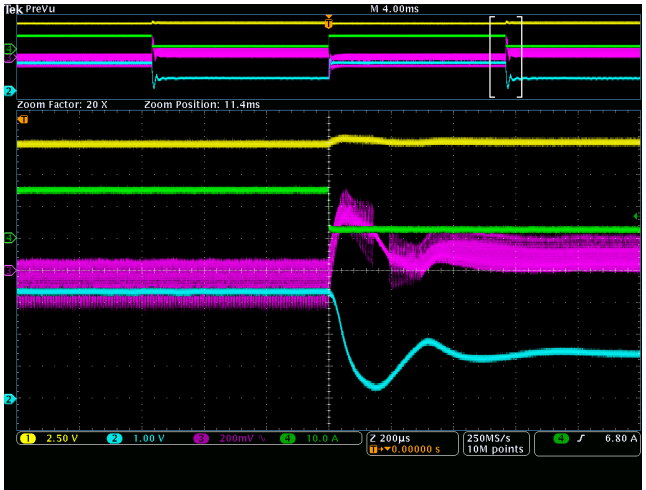

LLC Waveform – Step response 15 A → 2 A – detail

— CH1 – V_{out} DC — CH2 – LLC FB — CH3 – V_{out} AC — CH4 – Output current

Figure 21. Demo-board LLC Stage Application Waveforms – Step Response

EVBUM2886

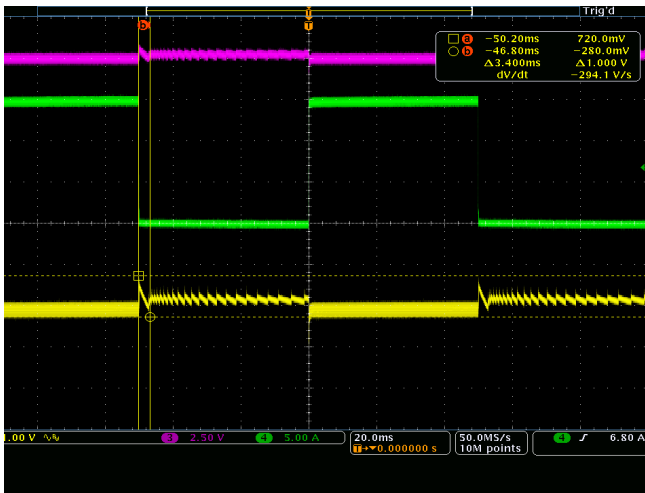

LLC Waveform – Step response 0 → 15 A at 10 Hz

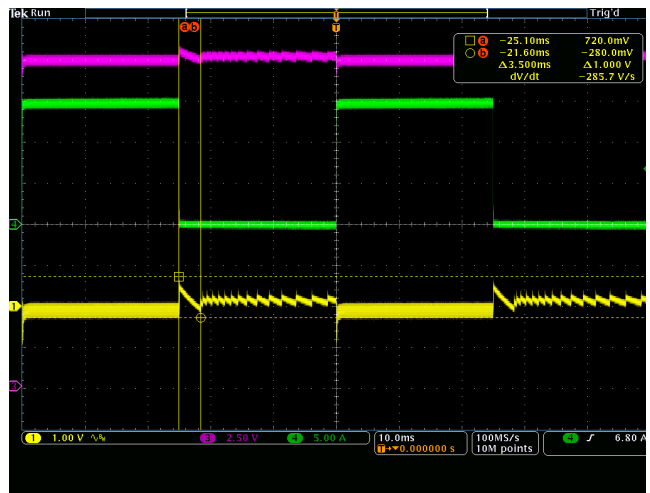

LLC Waveform – Step response 0 → 15 A at 20 Hz

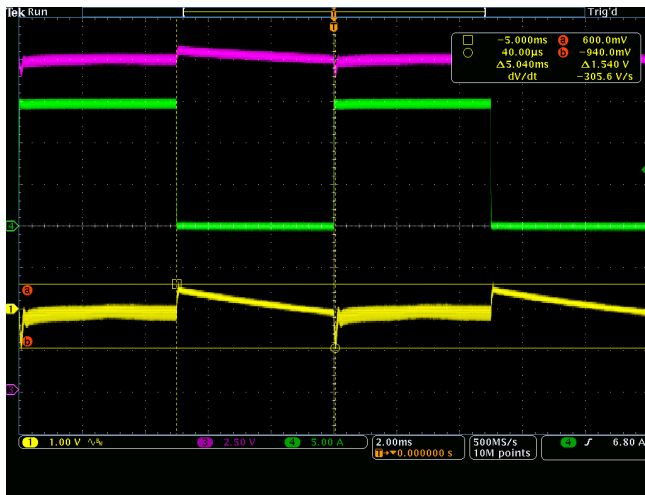

LLC Waveform – Step response 0 → 15 A at 100 Hz

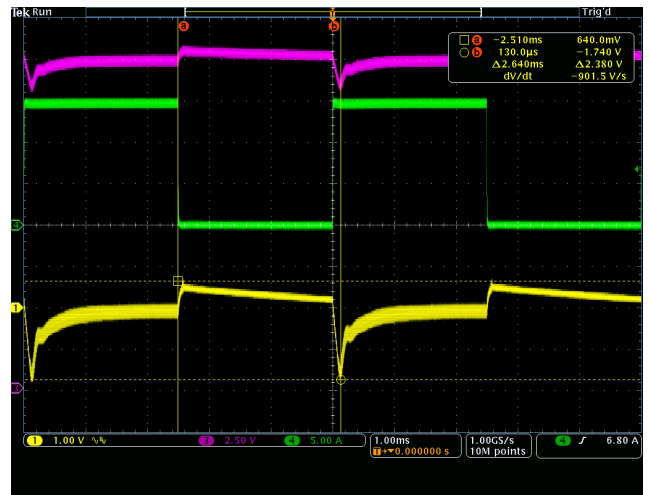

LLC Waveform – Step response 0 → 15 A at 200 Hz

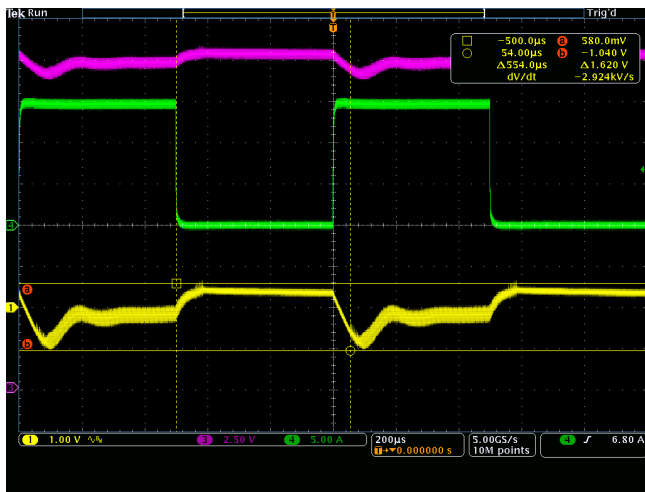

LLC Waveform – Step response 0 → 15 A at 1 kHz

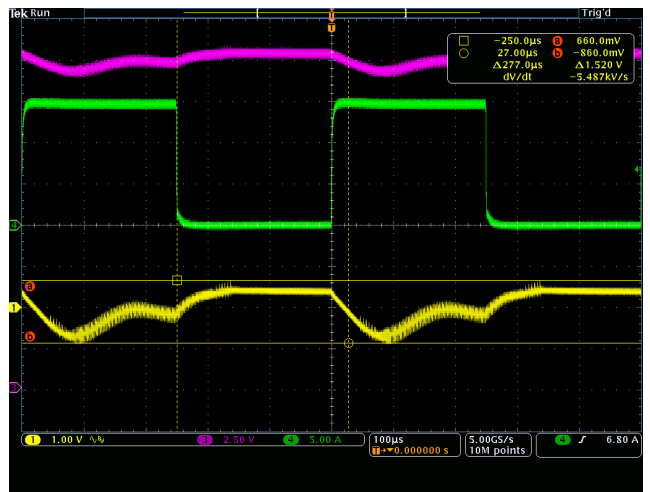

LLC Waveform – Step response 0 → 15 A at 2 kHz

— CH1 – $V_{out DC}$ — CH2 – LLC FB — CH3 – $V_{out AC}$ — CH4 – Output current

Figure 22. Demo-board LLC Stage Application Waveforms – Step Response for Various Loading Frequencies

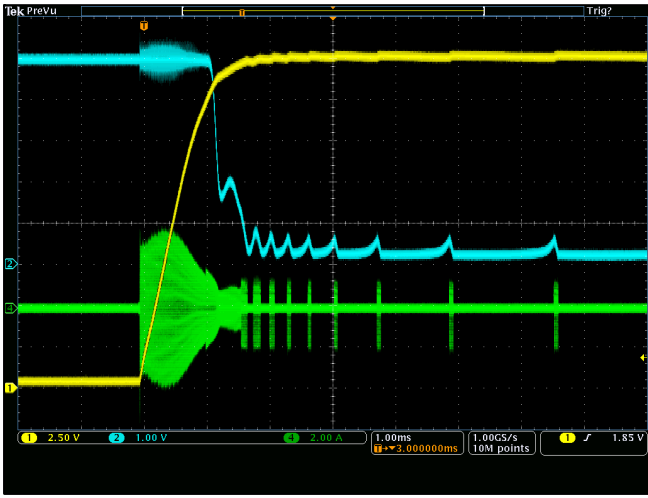

LLC Waveform – Start-up at 0 A

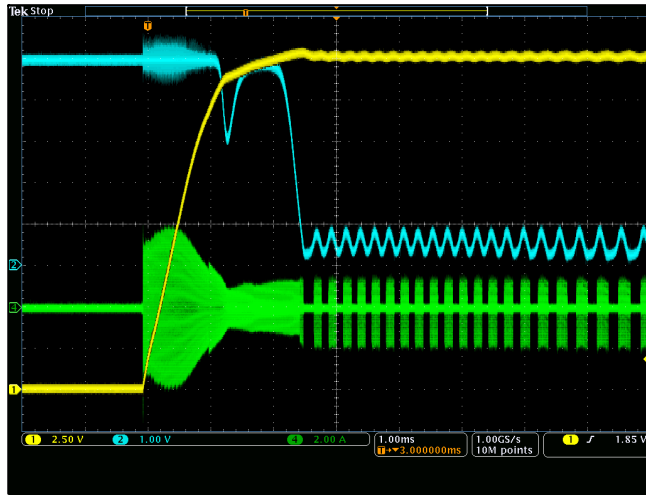

LLC Waveform – Start-up at 1 A CC

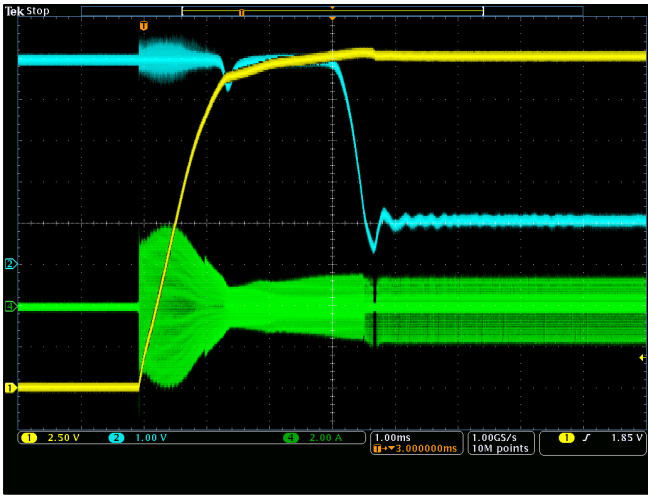

LLC Waveform – Start-up at 2 A CC

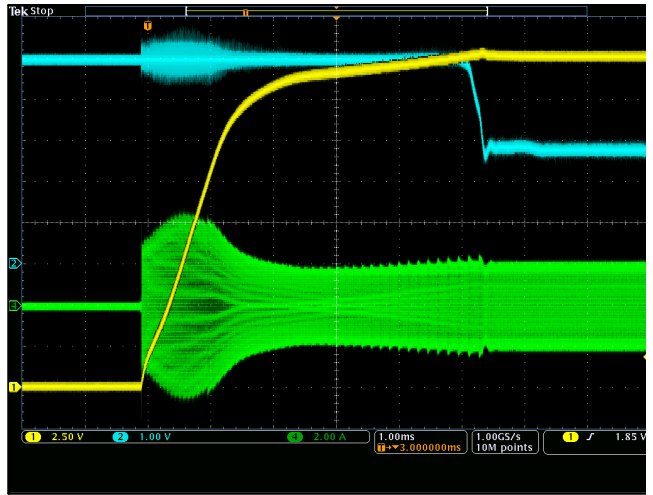

LLC Waveform – Start-up at 10 A CC

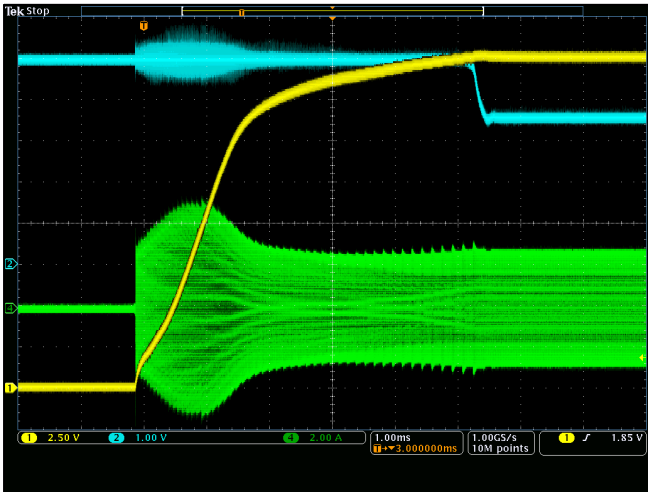

LLC Waveform – Start-up at 15 A CC

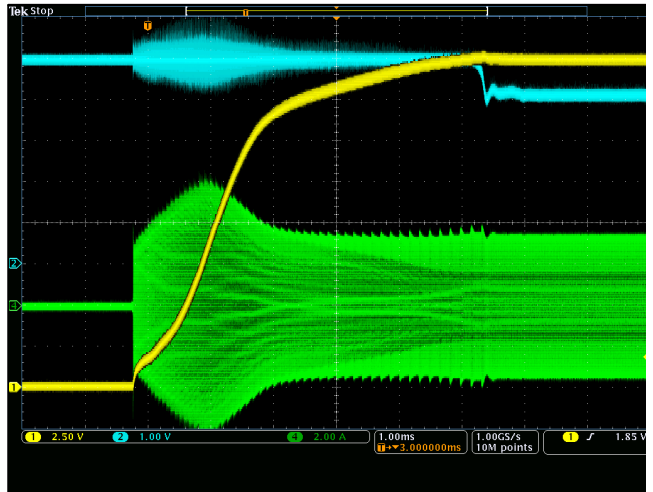

LLC Waveform – Start-up at overload 20 A CC

— CH1 – V_{out} DC — CH2 – LLC FB — CH3 – N/A — CH4 – Output current

Figure 23. Demo-board LLC Stage Application Waveforms – Start-up Sequence at Various Loads

DEMO-BOARD PHOTOGRAPHS

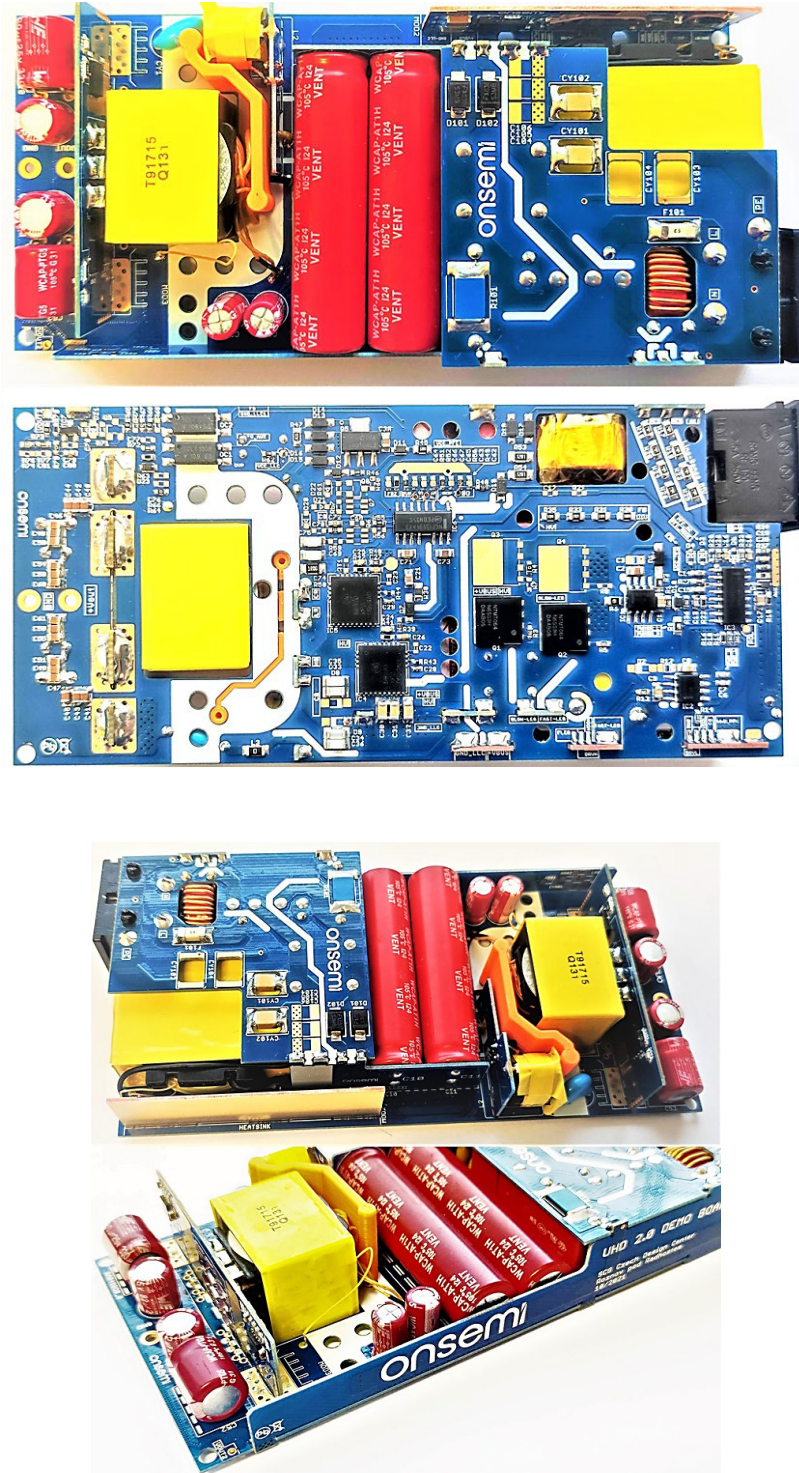
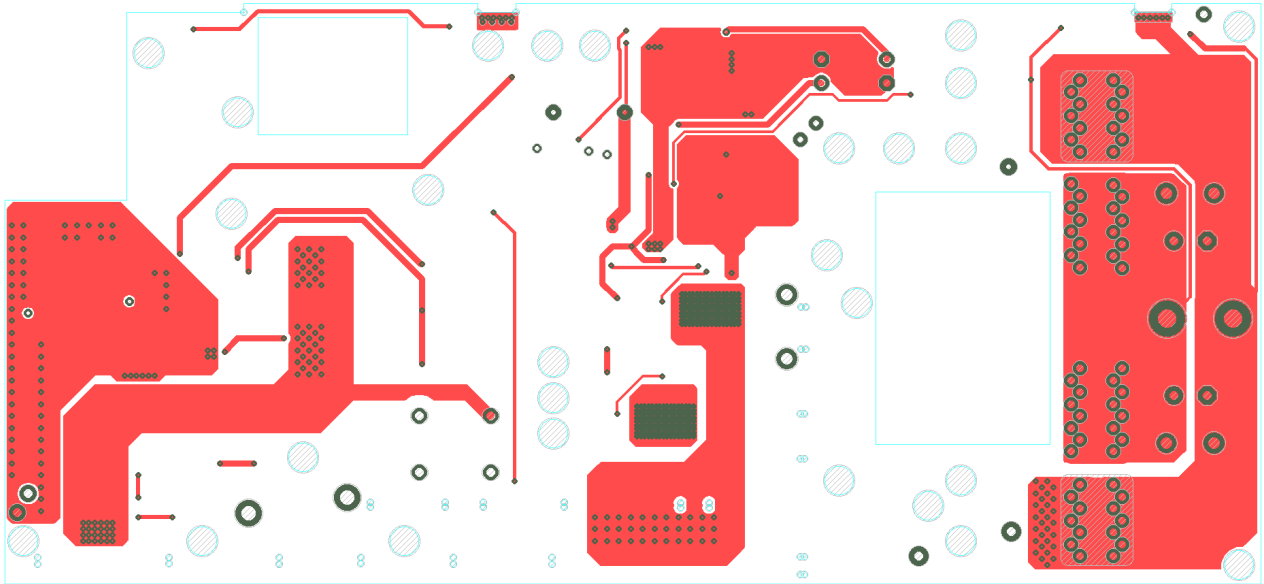

Figure 24. Ultra High Density and Efficiency 300 W Board Photographs

PCB Layout design

Following section depicts PCB layout design of boards that are needed to build whole demo-board.



Main board – Top copper

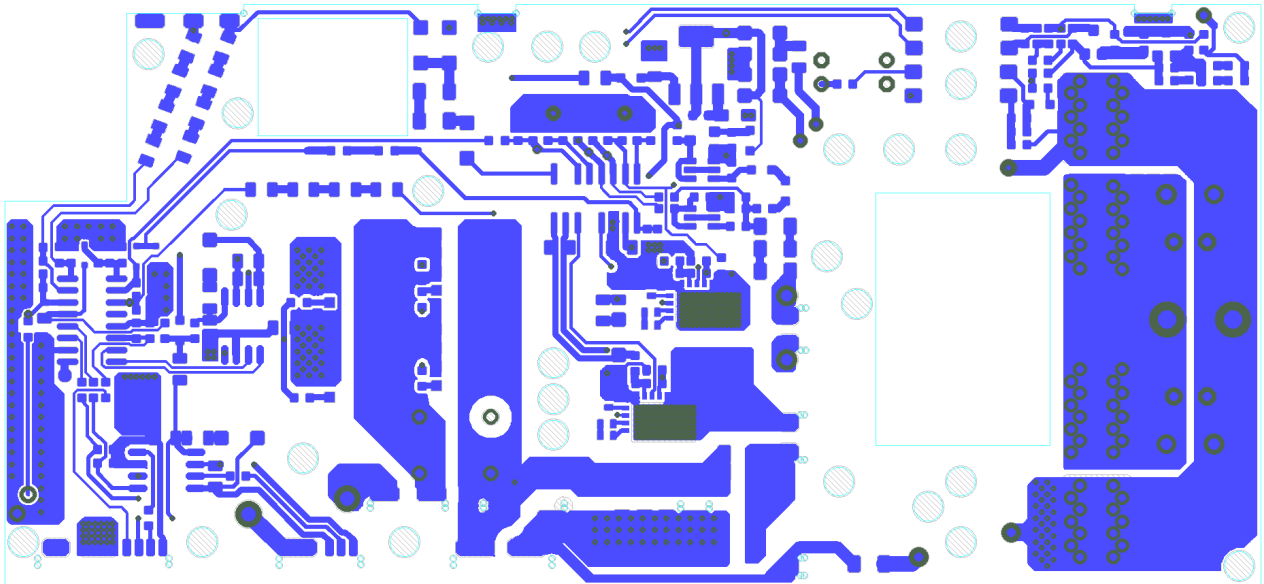

Main board – Bottom copper

Figure 25.

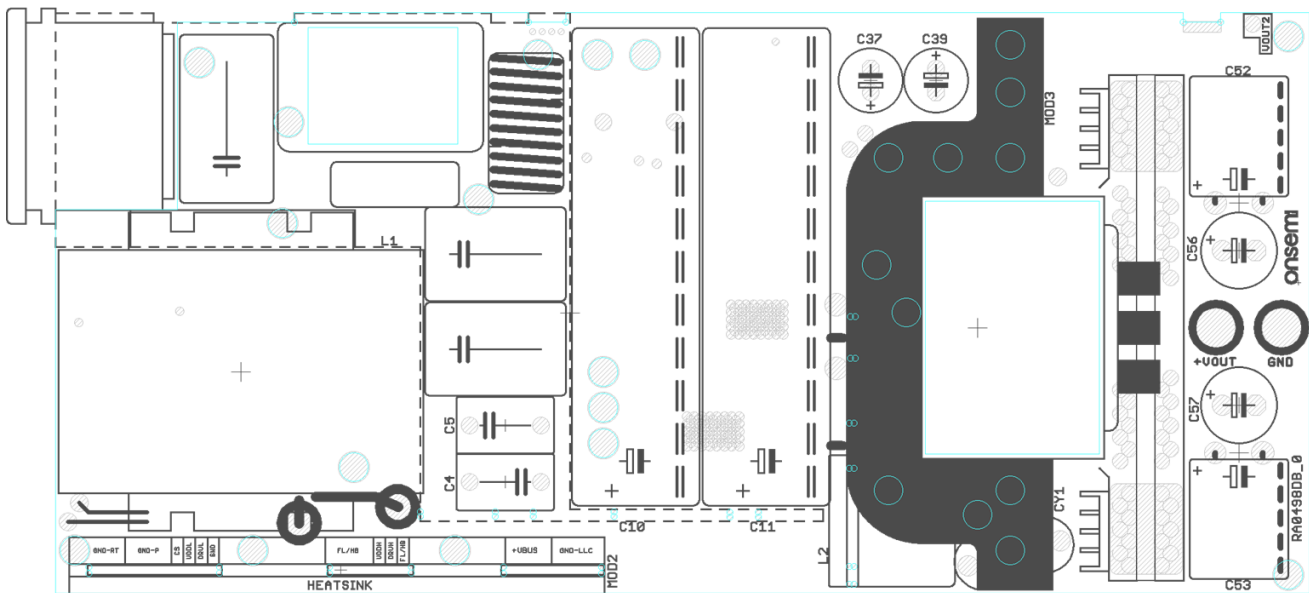

Main board – Top assembly

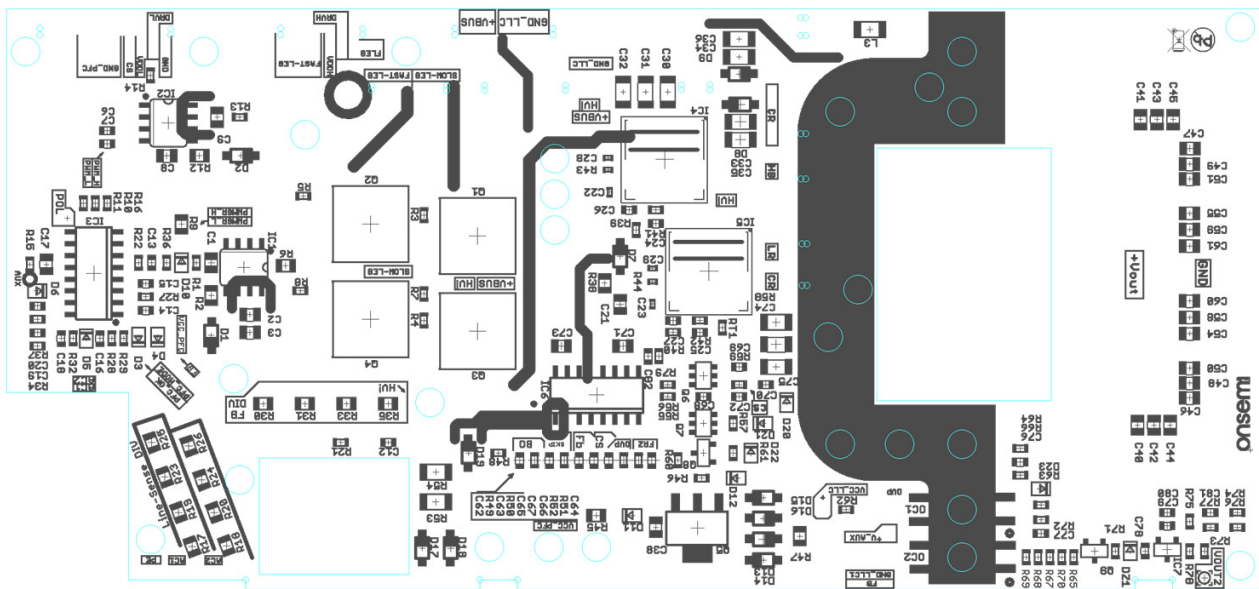

Main board – Bottom assembly

Figure 26.

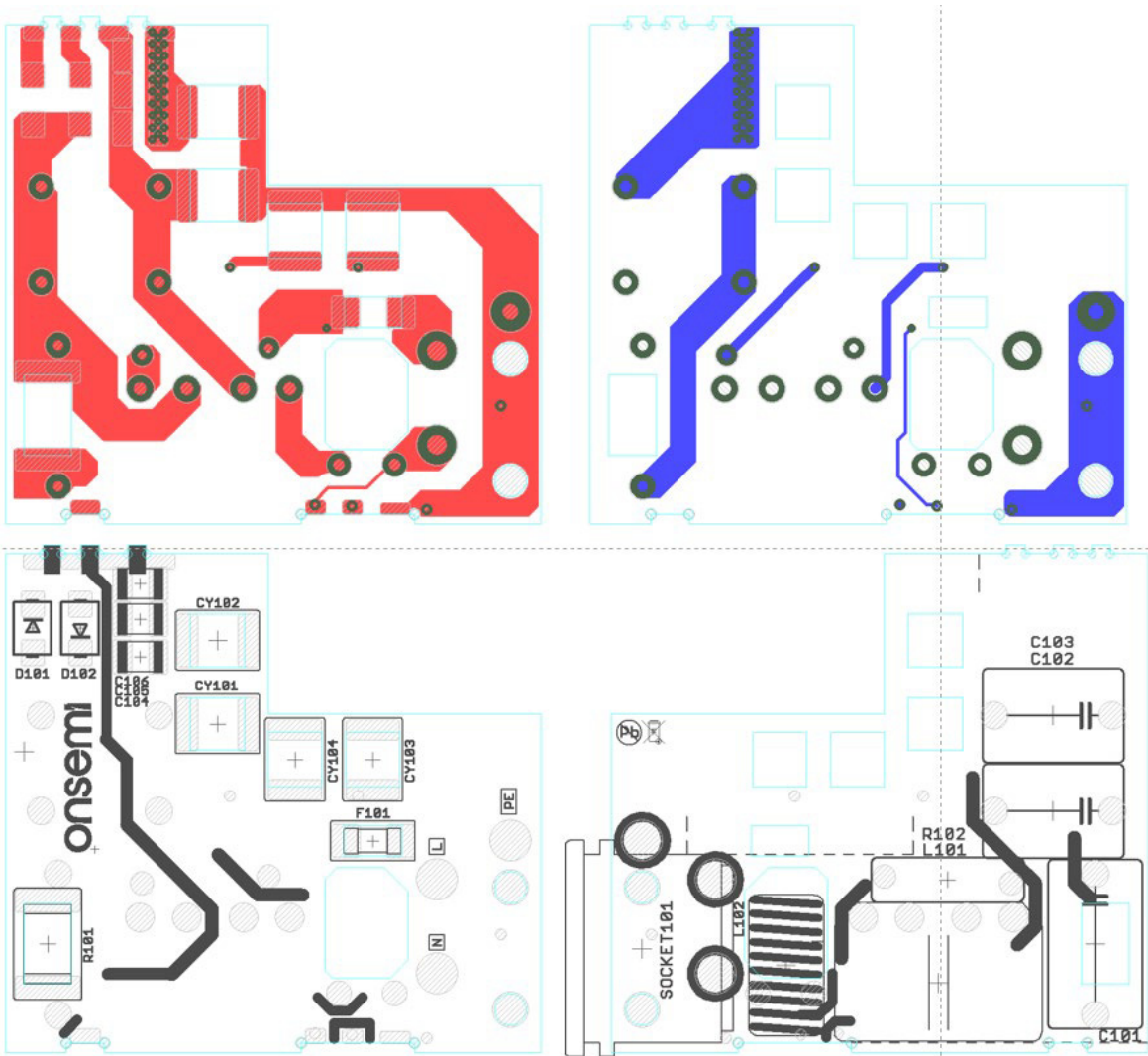

EMI Filter – Layout and Assembly

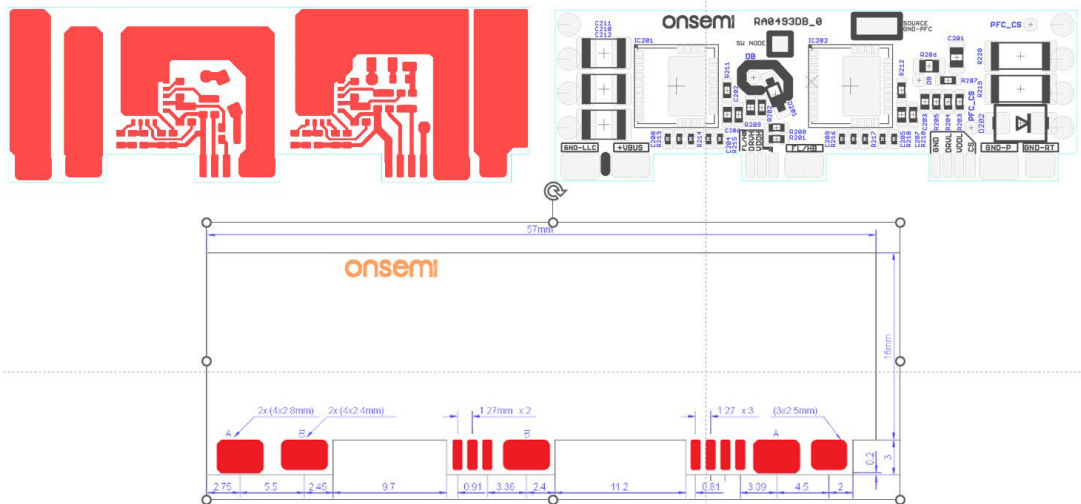

Figure 27. NCP58921 Based IMS HB Module – Top Copper Layer, Assembling Layer and PCB Dimensions

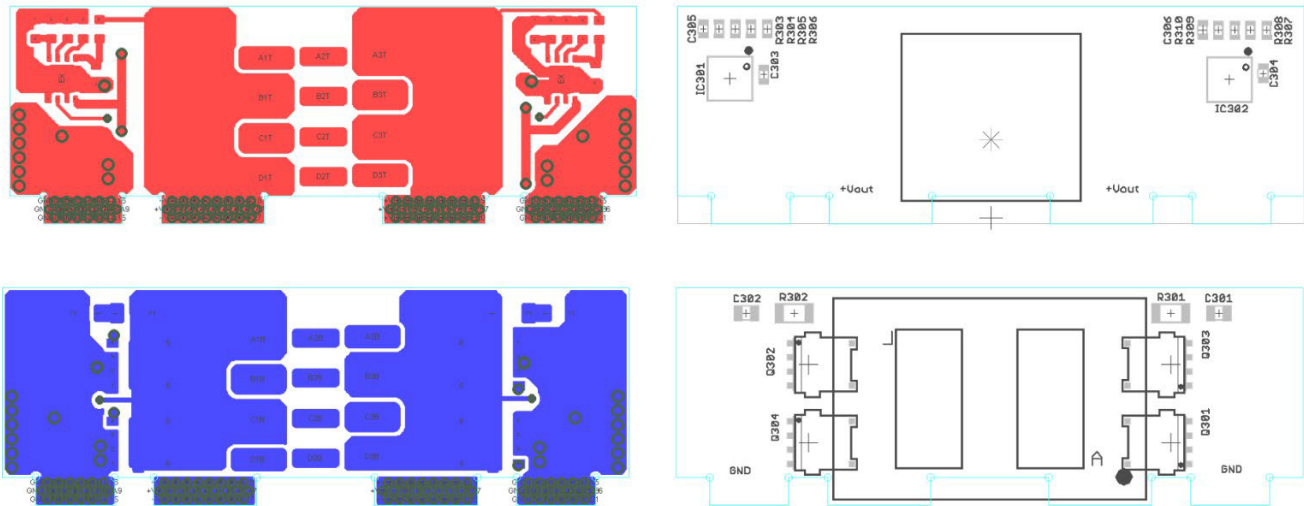

Figure 28. SR Module – Layout and Assembly

Literature and useful links

[1] NCP58920, Integrated Driver GaN Power Switch

<https://www.onsemi.com/download/> – TBD

[2] NCP58921, Integrated Driver GaN Power Switch

<https://www.onsemi.com/download/> – TBD

[3] NCP13994, Current Mode Resonant Controller with Integrated High Voltage Drivers, High Performance, Active X2

<https://www.onsemi.com/download/data-sheet/pdf/ncp13994-d.pdf>

[4] NCP1680, Totem Pole Critical Conduction Mode (CrM) Power Factor Correction Controller

<https://www.onsemi.com/support/sales>

[5] NCP51530 High Performance, 700 V– 3.5/3.0 A High and Low Side MOSFET Driver

<https://www.onsemi.com/download/data-sheet/pdf/ncp51530-d.pdf>

[6] NTMT064N65S3H, MOSFET – Power, N-Channel, SUPERFET III, FAST 650 V, 64 m, 40 A

<https://www.onsemi.com/download/data-sheet/pdf/ntmt064n65s3h-d.pdf>

[7] High Voltage 4.3 A High and Low Side Driver, HB MOSFET Driver

<https://www.onsemi.com/download/data-sheet/pdf/ncp5183-d.pdf>

[8] NHP160SF/ NHP260SF, Planar Ultrafast Rectifier, 600 V, 1/ 2 A

<https://www.onsemi.com/download/data-sheet/pdf/nhp160sf-d.pdf>

<https://www.onsemi.com/download/data-sheet/pdf/nhp260sf-d.pdf>

[9] Insulated Metal Substrate Half-Bridge Module based on NCP5892x 650V Integrated Driver GaN,

Evaluation Board User’s Manuals EVBUMxxxx – TBD

<https://www.onsemi.com/download/> – TBD

EVBUM2886

BILL OF MATERIALS

BRD	Parts	Qty	Value	Part number	Package	Tolerance	Replacement	MANUFACTURER
EMI FILTER	C101	1	680 nF / 310 VAC	890334027006	C-EUC150-100x180	±10%	NOT ALLOWED	WURTH
	C102, C103	2	470 nF / 310 VAC	890334024005	C-EUC125X100x150	±10%	NOT ALLOWED	WURTH
	C104, C105, C106	3	NU	N/A	C-EUC4532	-	N/A	N/A
	CY101, CY102	2	1000 pF 250 VAC	8853522130111	C2211	±10%	NOT ALLOWED	WURTH
	CY103, CY104	2	NU	N/A	C-EUWE-EMI_SMD	-	N/A	N/A
	D101, D102	2	S3MB	S3MB	DO214AA	-	ALLOWED	ONSEMI
	F101	1	T5 A, SLOW FUSE	T5 A, 0476005.MR	TE5M	-	ALLOWED	LITTELFUSE
	L101	1	750344559	WURTH, 750344559 Sumida, 04291T319	THT	±20%	NOT ALLOWED	WURTH Sumida
	L102	1	90 µH	7447013	THT	±20%	NOT ALLOWED	WURTH
	R101	1	VAR 275 V AC, 250 A, 80 pF	V430CH8	SMD 3220	-	ALLOWED	LITTELFUSE
	R102	1	WIRED STRAP	N/A	Thermistor 15 mm	-	N/A	N/A
	SOCKET101	1	SOCKET771W-BX2/01	771W-BX2/01	771W-BX2/01	-	ALLOWED	Qualtek
MAIN BOARD	C1, C8, C17, C21, C71	5	1 0 µF / 25 V	VARIOUS	C0805	±20%	ALLOWED	VARIOUS
	C14, C15, C18, C19, C65	5	1 nF / 25 V	885012006044	C0603	±5%	ALLOWED	WURTH
	C16, C24, C25, C62, C63, C64, C66	7	10 nF / 25 V	885012206065	C0603	±10%	ALLOWED	WURTH
	C2, C40, C41, C42, C43, C44, C45, C46, C47, C48, C49, C50, C51, C54, C55, C58, C59, C60, C61	19	2.2 µF / 25 V	885012107016	C0805	±20%	ALLOWED	WURTH
	C22, C23	2	NU	N/A	C0402	-	N/A	N/A
	C26, C27	2	1 µF / 25 V	885012206076	C0603	±10%	ALLOWED	WURTH
	C28, C29	2	100 nF / 25 V	885012205085	C0402	±10%	ALLOWED	WURTH
	C3	1	NU	N/A	C0805	-	N/A	N/A
	C30, C31, C32	3	100 nF / 450V	VARIOUS	C1206	±10%	ALLOWED	VARIOUS
	C33, C34, C35, C36	6	2. 2 nF / 630 V, NPO (2 PCS ADDED)	885342008007	C1206	±5%	ALLOWED	WURTH
	C37	1	100 µF / 25 V	860130474004	TH E2,5-7	-	ALLOWED	WURTH
	C38, C73	2	4.7 µF / 25 V	885012208068	C0805	±10%	ALLOWED	WURTH
	C39	1	4 7 µF / 63 V	860020773013	E2,5-7	-	ALLOWED	WURTH
	C4, C5	2	1. 5 nF / 500 VAC	VARIOUS	TH C075-063X106	±20%	ALLOWED	VARIOUS
	C52, C53	2	330 µF / 25 V	870025575009	TH E5-10,5	-	NOT ALLOWED	WURTH
	C56, C57	2	100 µF / 25 V	870025574005	TH E3,5-8	-	NOT ALLOWED	WURTH
	C6, C7, C13	3	100 pF / 50 V/ NPO	885012006057	C0603	±5%	ALLOWED	WURTH
	C67	1	33 pF / 50 V	885012006054	C0603	±5%	ALLOWED	WURTH

EVBUM2886

BILL OF MATERIALS

BRD	Parts	Qty	Value	Part number	Package	Tolerance	Replacement	MANUFACTURER
	C72, C80	2	2.2 nF / 50 V	885012007065	C0603	±5%	ALLOWED	WURTH
	C74, C75	2	100 pF / 2 kV NP0	885342008011	C1206	±5%	ALLOWED	WURTH
	C9	1	220 nF / 50 V	885012207074	C0805	±10%	ALLOWED	WURTH
	C10 (2 PCS)	2	100 µF / 420 V	860241978002 – AVAILABLE ON REQUEST!	TH E5-13	±20%	NOT ALLOWED	WURTH
	CY1	1	3n3 / CY	WKP332MCPJE0KR	YC10B5	±20%	ALLOWED	Vishay
	C12, C20, C68, C69, C70, C76, C77, C78, C79, C81	10	NU	N/A	C0603	N/A	N/A	N/A
	D1, D7	2	NHP260	NHP260	SOD123	-	NOT ALLOWED	Onsemi
	D10	1	BAS20H	BAS20HT1G	SOD323	-	NOT ALLOWED	Onsemi
	D11	1	BAT54H	BAT54HT1G	SOD323	-	NOT ALLOWED	Onsemi
	D12	1	MM3Z18V	MM3Z18VT1G	SOD323	-	NOT ALLOWED	Onsemi
	D13, D14, D15, D16	4	MBR2H100S	MBR2H100SFT3G	SOD123	-	NOT ALLOWED	Onsemi
	D17, D18, D19	3	S1JFL	SOD123	SOD123	-	NOT ALLOWED	Onsemi
	D2	1	NU	N/A	SOD123	-	N/A	N/A
	D20, D21, D22, DZ1	4	NU	N/A	SOD323	-	N/A	N/A
	D23	1	MM3Z20V	SOD323	SOD323	-	NOT ALLOWED	Onsemi
	D3	1	NU	N/A	SOD323	-	N/A	N/A
	D4, D5	2	NU	N/A	SOD323	-	N/A	N/A
	D6	1	BAT54HT1G	BAT54HT1G	SOD323	-	NOT ALLOWED	Onsemi
	D8, D9	2	NU	N/A	SOD123	-	N/A	N/A
	IC1	1	NCP5183	NCP5183DR2G	SO08-HVDRV	-	NOT ALLOWED	Onsemi
	IC2	1	NCP51530	NCP51530ADR2G	SO08-HVDRV	-	NOT ALLOWED	Onsemi
	IC3	1	NCP1680	NCP1680AAD1R2G	SO16	-	NOT ALLOWED	Onsemi
	IC4, IC5	2	NCP58920-PROTOTYPE	NOT AVAILABLE YET	TQFN26	-	NOT ALLOWED	Onsemi
	IC6	1	NCP13994-PROTOTYPE	NOT AVAILABLE YET	SO16	-	NOT ALLOWED	Onsemi
	IC7	1	NCP431BCSNT1G	NCP431BCSNT1G	SO16	-	NOT ALLOWED	Onsemi
	L1	1	150 µH	T91905	ER38	±20%	NOT ALLOWED	Sumida
	L2	1	8 µH	T91760	RM5	±20%	NOT ALLOWED	Sumida
	L3	1	0R	(0 Ω jumper)	SMD 1206	-	ALLOWED	VARIOUS
	OC1, OC2	2	TCLT1008, or 140100146000	TCLT1008, 140100146000	SMD SOP-4	-	ALLOWED	Vishay, WURTH
	Q1, Q2	2	NTMT064N65S3H	NTMT064N65S3H	TDFN4 8x8	-	NOT ALLOWED	Onsemi
	Q3, Q4	2	NU	N/A	TDFN4 8x8	-	N/A	N/A
	Q5	1	FDT1600N10ALZ	FDT1600N10ALZ	SOT223	-	NOT ALLOWED	Onsemi
	Q6, Q7	2	NU	N/A	SOT23-6	-	N/A	N/A
	Q8	1	NU	N/A	SOT23	-	N/A	N/A
	Q9	1	NU	N/A	SOT23	-	N/A	N/A

EVBUM2886

BILL OF MATERIALS

BRD	Parts	Qty	Value	Part number	Package	Tolerance	Replacement	MANUFACTURER
	R1, R3, R5, R10, R11, R13, R14, R36, R40	9	10 R	VARIOUS	R0603	± 1%	ALLOWED	VARIOUS
	R15, R22, R78	3	10 k	VARIOUS	R0603	± 1%	ALLOWED	VARIOUS
	R16, R41, R42, R51, R63	5	1 k	VARIOUS	R0603	±1%	ALLOWED	VARIOUS
	R17, R18, R19, R20, R23, R24	6	2.4 M	VARIOUS	R0805	±1%	ALLOWED	VARIOUS
	R2, R9, R45	3	10 R	VARIOUS	R0805	±1%	ALLOWED	VARIOUS
	R25, R26	2	2.7 M	VARIOUS	R0805	±1%	ALLOWED	VARIOUS
	R27, R72, R77	3	68 k	VARIOUS	R0603	±1%	ALLOWED	VARIOUS
	R28	1	33 k	VARIOUS	R0603	±1%	ALLOWED	VARIOUS
	R30	1	1 M	VARIOUS	R0805	±1%	ALLOWED	VARIOUS
	R31, R33, R35	3	3.3 M	VARIOUS	R0805	±1%	ALLOWED	VARIOUS
	R32, R34	2	100 k	VARIOUS	R0603	±1%	ALLOWED	VARIOUS
	R37	1	470 k	VARIOUS	R0603	±1%	ALLOWED	VARIOUS
	R38	1	600 R / 100 MHz	74279220601	SMD 805	-	NOT ALLOWED	WURTH
	R39	1	1 R	VARIOUS	R0603	±1%	ALLOWED	VARIOUS
	R4, R64, R65, R68, R73	5	0 R	VARIOUS	R0603	±5%	ALLOWED	VARIOUS
	R43, R44	2	33 R	VARIOUS	R0402	±1%	ALLOWED	VARIOUS
	R46	1	22 k	VARIOUS	R0603	±1%	ALLOWED	VARIOUS
	R47	1	2.2 R	VARIOUS	R0805	±1%	ALLOWED	VARIOUS
	R48	1	5.1 k	VARIOUS	R0603	±1%	ALLOWED	VARIOUS
	R49	1	62 k	VARIOUS	R0603	±1%	ALLOWED	VARIOUS
	R50	1	4.3 k	VARIOUS	R0603	±1%	ALLOWED	VARIOUS
	R52, R62	2	15k	VARIOUS	R0603	±1%	ALLOWED	VARIOUS
	R53, R54	2	1.2k	VARIOUS	R1206	±1%	ALLOWED	VARIOUS
	R55	1	100R	VARIOUS	R0603	±1%	ALLOWED	VARIOUS
	R58	1	1R	VARIOUS	R1206	±1%	ALLOWED	VARIOUS
	R59	1	2.2k	VARIOUS	R0603	±1%	ALLOWED	VARIOUS
	R6	1	0R	VARIOUS	R0805	±5%	ALLOWED	VARIOUS
	R67	1	820R	VARIOUS	R0603	±1%	ALLOWED	VARIOUS
	R75	1	47k	VARIOUS	R0603	±1%	ALLOWED	VARIOUS
	R76	1	3.6k	VARIOUS	R0603	±1%	ALLOWED	VARIOUS
	R7, R8, R21, R56, R57, R60, R61, R66, R69, R70, R71, R74	12	NU	N/A	R0603	-	N/A	N/A
	R12	1	NU	N/A	R0805	-	N/A	N/A
	R29	1	NU	N/A	R0603	-	N/A	N/A
	RT1	1	NU	N/A	R0603	-	N/A	N/A

EVBUM2886

BILL OF MATERIALS

BRD	Parts	Qty	Value	Part number	Package	Tolerance	Replacement	MANUFACTURER
FAST LEG MODULE	D202	1	NU	N/A	DO214AA	-	N/A	N/A
	C201	1	10 μ F / 25 V	VARIOUS	C0805	\pm 20%	ALLOWED	VARIOUS
	C202, C203	2	470 pF / 50 V	885012006061	C0603	\pm 5%	ALLOWED	WURTH
	C204, C205, C208, C209	4	100 nF / 25 V	885012205085	C0402	\pm 10%	ALLOWED	WURTH
	C206, C207	2	2.2 μ F / 25 V	VARIOUS	C0805	\pm 20%	ALLOWED	VARIOUS
	C210, C211, C212	3	100 nF / 450 V	VARIOUS	R6332	\pm 10%	ALLOWED	VARIOUS
	D201	1	NHP260	NHP260	SOD123	-	NOT ALLOWED	Onsemi
	IC201, IC202	2	NCP58921-PROTOTYPE	NOT AVAILABLE YET	TQFN26	-	NOT ALLOWED	Onsemi
	R201, R203, R204, R207, R208	5	3.3 R	VARIOUS	R0603	\pm 1%	ALLOWED	VARIOUS
	R202, R205	2	0 R	VARIOUS	R0603	\pm 5%	ALLOWED	VARIOUS
	R206	1	3.3 R	VARIOUS	R0805	\pm 1%	ALLOWED	VARIOUS
	R209, R210, R211, R212	4	1 k	VARIOUS	R0603	\pm 1%	ALLOWED	VARIOUS
	R213, R216	2	33 R	VARIOUS	R0603	\pm 1%	ALLOWED	VARIOUS
	R214, R217	2	NU	N/A	R0402	-	N/A	N/A
	R215, R218	2	0 R	VARIOUS	R0402	\pm 5%	ALLOWED	VARIOUS
	R219	1	100 mR	VARIOUS	R6332	\pm 1%	ALLOWED	VARIOUS
	R220	1	NU	N/A	R6332	-	N/A	N/A
SR MOULE	R306, R307	2	10 R	VARIOUS	R0603	\pm 1%	ALLOWED	VARIOUS
	C301, C302	2	470 pF / 200 V	885342207002	C0805	\pm 10%	ALLOWED	WURTH
	C303, C304	2	2.2 μ F / 25 V	VARIOUS	C0805	\pm 20%	ALLOWED	VARIOUS
	C305, C306	2	1 nF / 25 V	885012006044	C0603	\pm 10%	ALLOWED	WURTH
	IC301, IC302	2	NCP4306	NCP4306ABAZZZA (P/N not released)	DFN-8	-	NOT ALLOWED	onsemi
	Q301, Q302, Q303, Q304	4	NTMYS3D3N06	NTMYS3D3N06CLTWG	SO8FL	-	NOT ALLOWED	onsemi
	R301, R302	2	33 R	VARIOUS	R1206	\pm 1%	ALLOWED	VARIOUS
	R303, R310	2	27 k	VARIOUS	R0603	\pm 1%	ALLOWED	VARIOUS
	R304, R309	2	1.5 k	VARIOUS	R0603	\pm 1%	ALLOWED	VARIOUS
	R305, R308	2	6.8 k	VARIOUS	R0603	\pm 1%	ALLOWED	VARIOUS
	X301	1	N = 10:1	T91715	-	-	NOT ALLOWED	SUMIDA

onsemi, **Onsemi**, and other names, marks, and brands are registered and/or common law trademarks of Semiconductor Components Industries, LLC dba "**onsemi**" or its affiliates and/or subsidiaries in the United States and/or other countries. **onsemi** owns the rights to a number of patents, trademarks, copyrights, trade secrets, and other intellectual property. A listing of **onsemi**'s product/patent coverage may be accessed at www.onsemi.com/site/pdf/Patent-Marking.pdf. **onsemi** is an Equal Opportunity/Affirmative Action Employer. This literature is subject to all applicable copyright laws and is not for resale in any manner.

The evaluation board/kit (research and development board/kit) (hereinafter the "board") is not a finished product and is not available for sale to consumers. The board is only intended for research, development, demonstration and evaluation purposes and will only be used in laboratory/development areas by persons with an engineering/technical training and familiar with the risks associated with handling electrical/mechanical components, systems and subsystems. This person assumes full responsibility/liability for proper and safe handling. Any other use, resale or redistribution for any other purpose is strictly prohibited.

THE BOARD IS PROVIDED BY ONSEMI TO YOU "AS IS" AND WITHOUT ANY REPRESENTATIONS OR WARRANTIES WHATSOEVER. WITHOUT LIMITING THE FOREGOING, ONSEMI (AND ITS LICENSORS/SUPPLIERS) HEREBY DISCLAIMS ANY AND ALL REPRESENTATIONS AND WARRANTIES IN RELATION TO THE BOARD, ANY MODIFICATIONS, OR THIS AGREEMENT, WHETHER EXPRESS, IMPLIED, STATUTORY OR OTHERWISE, INCLUDING WITHOUT LIMITATION ANY AND ALL REPRESENTATIONS AND WARRANTIES OF MERCHANTABILITY, FITNESS FOR A PARTICULAR PURPOSE, TITLE, NON-INFRINGEMENT, AND THOSE ARISING FROM A COURSE OF DEALING, TRADE USAGE, TRADE CUSTOM OR TRADE PRACTICE.

onsemi reserves the right to make changes without further notice to any board.

You are responsible for determining whether the board will be suitable for your intended use or application or will achieve your intended results. Prior to using or distributing any systems that have been evaluated, designed or tested using the board, you agree to test and validate your design to confirm the functionality for your application. Any technical, applications or design information or advice, quality characterization, reliability data or other services provided by **onsemi** shall not constitute any representation or warranty by **onsemi**, and no additional obligations or liabilities shall arise from **onsemi** having provided such information or services.

onsemi products including the boards are not designed, intended, or authorized for use in life support systems, or any FDA Class 3 medical devices or medical devices with a similar or equivalent classification in a foreign jurisdiction, or any devices intended for implantation in the human body. You agree to indemnify, defend and hold harmless **onsemi**, its directors, officers, employees, representatives, agents, subsidiaries, affiliates, distributors, and assigns, against any and all liabilities, losses, costs, damages, judgments, and expenses, arising out of any claim, demand, investigation, lawsuit, regulatory action or cause of action arising out of or associated with any unauthorized use, even if such claim alleges that **onsemi** was negligent regarding the design or manufacture of any products and/or the board.

This evaluation board/kit does not fall within the scope of the European Union directives regarding electromagnetic compatibility, restricted substances (RoHS), recycling (WEEE), FCC, CE or UL, and may not meet the technical requirements of these or other related directives.

FCC WARNING – This evaluation board/kit is intended for use for engineering development, demonstration, or evaluation purposes only and is not considered by **onsemi** to be a finished end product fit for general consumer use. It may generate, use, or radiate radio frequency energy and has not been tested for compliance with the limits of computing devices pursuant to part 15 of FCC rules, which are designed to provide reasonable protection against radio frequency interference. Operation of this equipment may cause interference with radio communications, in which case the user shall be responsible, at its expense, to take whatever measures may be required to correct this interference.

onsemi does not convey any license under its patent rights nor the rights of others.

LIMITATIONS OF LIABILITY: **onsemi** shall not be liable for any special, consequential, incidental, indirect or punitive damages, including, but not limited to the costs of requalification, delay, loss of profits or goodwill, arising out of or in connection with the board, even if **onsemi** is advised of the possibility of such damages. In no event shall **onsemi**'s aggregate liability from any obligation arising out of or in connection with the board, under any theory of liability, exceed the purchase price paid for the board, if any.

The board is provided to you subject to the license and other terms per **onsemi**'s standard terms and conditions of sale. For more information and documentation, please visit www.onsemi.com.

ADDITIONAL INFORMATION

TECHNICAL PUBLICATIONS:

Technical Library: www.onsemi.com/design/resources/technical-documentation
onsemi Website: www.onsemi.com

ONLINE SUPPORT: www.onsemi.com/support

For additional information, please contact your local Sales Representative at www.onsemi.com/support/sales