

Evaluation Board for 1200 V M3S 4-PACK SiC MOSFET Module User's Manual

EVBUM2878G-EVB

Evaluation Boards Description

Evaluation board is designed for evaluations **onsemi** 1200 V M3S (Full bridge) 4PACK modules in F2 package.

These products are used in energy infrastructure applications such as PV inverters, UPS, or EV chargers to improve efficiency and power density compared with IGBT or super junction MOSFET solutions. This manual describes the board function, board layout and application test description. It includes details of layout, schematics, and bill of materials.

Purpose of the evaluation board is double pulse switching test and open loop power test of **onsemi** full bridge modules.

Evaluation board supports **onsemi** modules:

- NXH011F120M3F2PTHG
- NXH007F120M3F2PTHG
(module is not included in BOM)

4 PACK module is controlled by isolated single gate drivers.

The driver provides 2.5 kV RMS insulation between primary and secondary side. The gate drive voltage is supplied through an isolated DC/DC Source. The board includes an integrated DC-link with the option of assembling different types of film capacitors.

The evaluation board can be connected to an external controller providing PWM inputs and handling fault signals.

Evaluation Board Operation

The board is designed as RoHS compliant. Design of the board was not qualified for manufacturing. No tests were made on whole operating temperature range. No lifetime tests were performed. The board must be used in lab environment only and must be operated by skilled personal trained on all safety standards. Further details of used components are in their respective datasheets.

Features

- 4 Layer FR4 PCB with 70 μ m Copper Thickness
- High Thermal Emissivity – Black PCB Color
- 4 Isolated Single Gate Drivers with 2.5 kV Insulation
- Connector Base for Input and Output Signals
- Integrated Film DC-link
- Mounting Holes for Connection Rogowski Coil and Measurement Probes
- Low Inductance PCB Layout

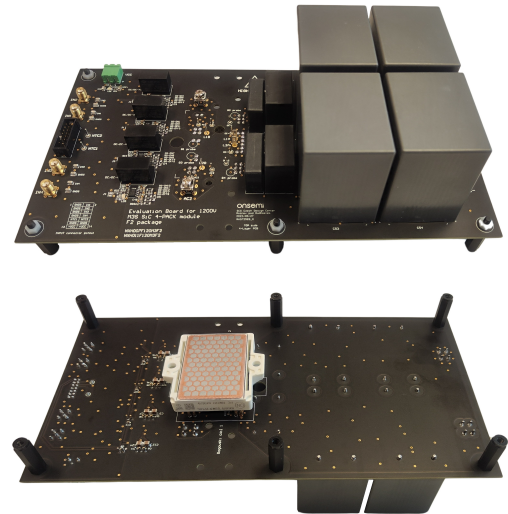

Figure 1. Evaluation Board for 4PACK Modules

APPLICATIONS INFORMATION

Evaluation Board

The evaluation board contains the 4x single gate driver stage with NCD57084. Secondary side of gate drivers is supplied through an isolated 2 W DC/DC Source. Primary side +5 V, secondary side +18 V/-3 V (recommended for M3S option to replace with another voltage see BOM).

The power terminals AC1 and AC2 are center of the 4PACK for connecting the load. VDC+ and VDC- are used for external High Voltage Power source. The recommended capacity for the DC link is 180 µF (see BOM below).

For filtering high frequency, it is possible assembling snubber capacitors C1-C4 for filtering high frequency oscillations.

For AC double pulse test (DPT) is connect to inductor terminals COIL1A and COIL1B. The temperature inside the module is measured using the NTC1 and NTC2 pins. Multimeter with resistance measurement is suitable.

PCB Mechanical Dimension

PCB board outline dimensions are 275 mm x 141 mm, thickness PCB is 2mm. The board outline is shown in Figure 2. Thickness of the main board is 2.0 mm.

Holes for mechanical mounting of the heatsink are 6 x 4.2 mm. The PCB mask is black due to high thermal emissivity for measurement with thermal camera.

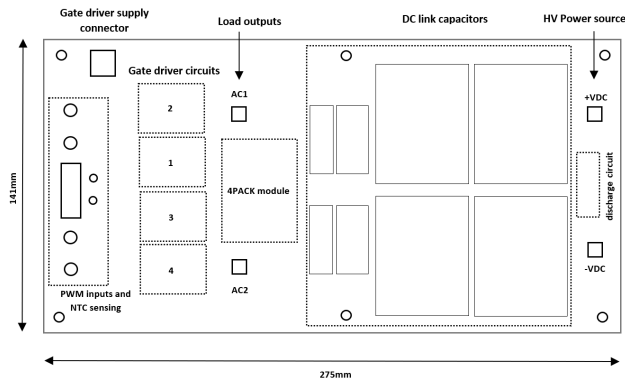

Figure 2. Simplify PCB Block Diagram

Gate Drivers – Fault Outputs

The NCD57084 gate driver has two protection functions, READY function “RDY” and DESAT. The RDY fault is triggered by UVLO at the secondary side of the driver. RDY is active LOW. RDY fault is cleared with rising edge of input PWM signal is high and secondary UVLO condition. is not present. At the first power up of the evaluation board the drivers will be in fault condition. Fault signal will be cleared with first PWM pulse. The second protection function of the gate driver desaturation protection “DESAT” is not used on this board.

Link to datasheet: [NCD57084/D](https://www.onsemi.com/pdf/datasheet/NCD57084/D)

Input PWM Signals

Input signals are connected to SMA connectors IN1– IN4 or to relevant PIN header marked INPUTS.

Pin layout is on Figure 3.

For input signals can be used external signal generator or microprocessor development board.

Input voltage level PWM according to datasheet:

V_{IL} Low Input Voltage 0–1.5 V

V_{IH} High Input Voltage 3.5–5 V

(V_{CC} voltage is +5 V)

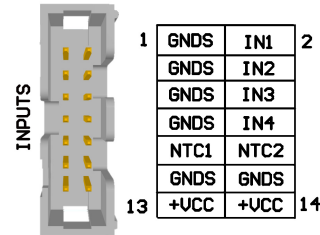

Figure 3. Connector INPUT Pin Layout

Electrical Rating

The board is rated to DC voltage input 800 Vdc. Maximum voltage in the DC link is 1000 V. There is no protection for exceeding maximum.

DC link voltage or for reverse polarity. No inrush current limitation is present on the board.

Be especially careful when working under high voltage during measurement. The DC link remains under Voltage several minutes after disconnecting the HV source. Discharge is provided by resistors R1–R24.

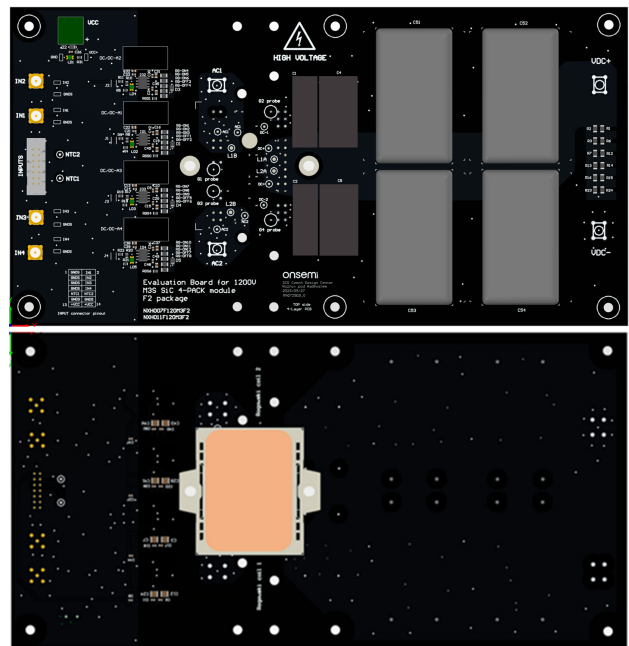

Figure 4. TOP and BOTTOM View Eval. Board

NTC Thermistor Sensing

The built-in NTC resistor monitors temperature inside module. Eval. board marked connectors NTC1 and NTC2. The resistance value corresponds 5 kΩ at 25°C.

Table 1. VALUE OF RESISTANCES AT DIFFERENT TEMPERATURE

Temp (°C)	Typ. Resistance (kΩ)	Temp (°C)	Typ. Resistance (kΩ)
-40	99.09	75	0.968
-25	44.44	100	0.493
0	13.72	125	0.271
25	5	150	0.159
50	2.083	175	0.099

Isolated DC-DC Driver Converter

Eval. board contains four separate DC-DC converters for supply secondary side of the drivers.

For driving **onsemi** 4PACK M3S modules is recommended gate driving -3 V/18 V.

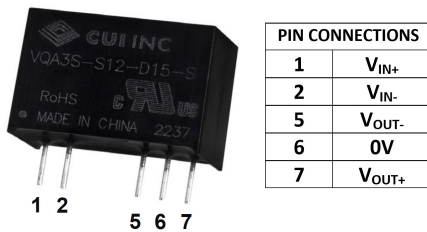

Figure 5. Pin Out DC-DC Converter CUI VQA3S-S5-D18-S

Gate Resistance - R_G

The choice of optimal value gate resistor is compromise between switching losses and VDS overshoot.

Low R_G value - high switching speed, low losses, higher VDS overshoot

High R_G value - low switching speed, higher losses, lower VDS overshoot

Recommended value:

NXH007F120M3F2PTHG - R_{GON} = 2R2

NXH011F120M3F2PTHG - R_{GON} = 3R9

(Assembled with R_{GON} = 3R9, R_{GOFF} - not populate)

Resistor type is for pulse withstanding in SMD 1206 package. Eval. board allows assembled more pieces in parallel for better heat distribution.

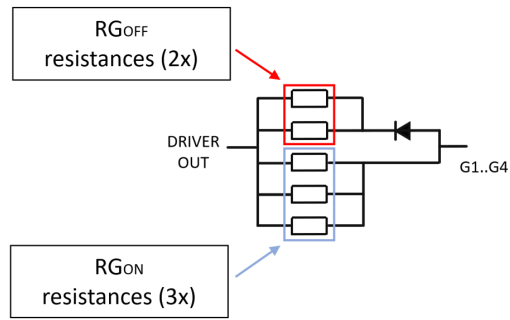

Figure 6. Gate Resistances Schematic

1200 V M3S 4PACK SIC MOSFET Module

Full bridge power modules containing 1200 V SiC MOSFET and NTC thermistor with HPS DBC.

onsemi offers in F2 package two R_{DS-ON} variants with same pinout.

1200 V 7 mΩ variant: NXH007F120M3F2PTHG

1200 V 11 mΩ variant: NXH011F120M3F2PTHG

Link to datasheets: [datasheets](#)

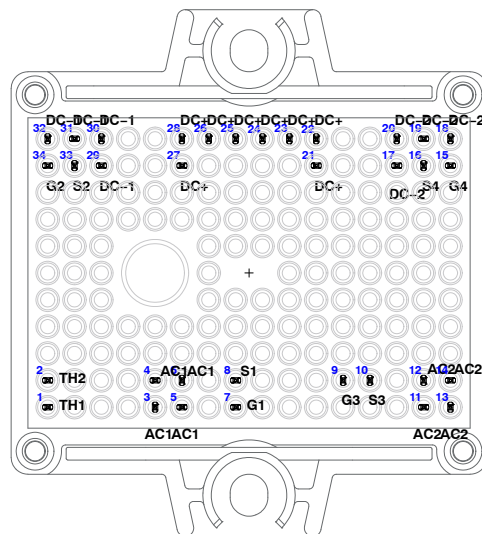
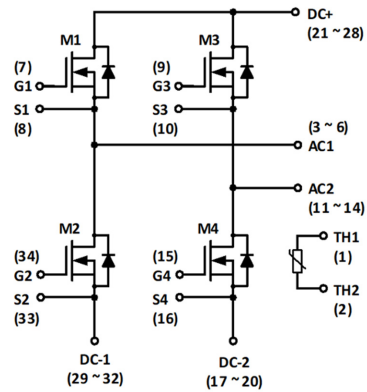

Figure 7. 4PACK Module Schematic and Pinout

EVALUATION TESTING

1) AC – Double Pulse Test

Switching AC test was performed with module NXH011F120M3F2PTHG.

Tested was half bridge LEG1 with M1, M2 switch. LEG2 half bridge is closed.

LOW side M2 MOSFET commuting with M1 high side body diode. Input pulse signal is connected to connector IN2 for LOW side switch M2. The IN1 connector for HIGH side switch is not connected (Gate Voltage M1 switch is -3 V). For better oscillation immunity is recommended short jumper J3 and J4.

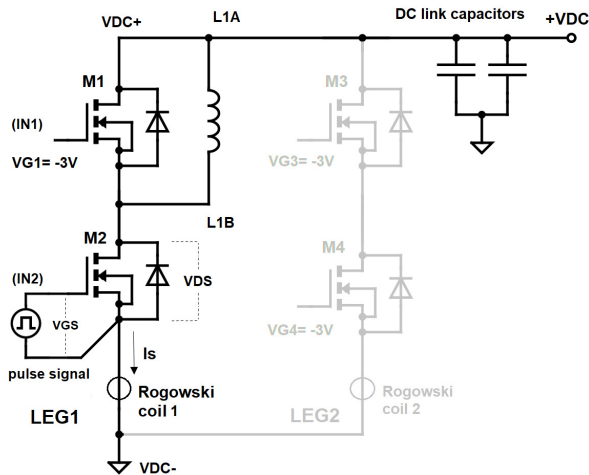

Figure 8. Double Pulse Test Schematic

Current was captured by Rogowski coil attached through the DC-1 pins. Mounting details of fixing the Rogowski coil to PCB, see Figure 11. probe type CWT MINI HF3R – picture on the left, iwatsu SS-685 – on the right. For high measurement accuracy is recommended probe with a high bandwidth.

Measurement Process

Connect the V_{GS} , V_{DS} probes and the Rogowski coil according to the picture. In the next step, connect the Load inductor to terminals L1A and L1B. Signal pulse generator to connector IN2. Plug +5V to terminal VCC and HV source to terminal VDC+ and VDC-.

Turn on the 5V power supply and start PWM operation. Increase the voltage of the HV source and monitor the V_{GS} , V_{DS} and I_D waveforms on the Oscilloscope.

For measurement in temperature $>25^{\circ}\text{C}$ is used hotplate. Temperature inside the module is monitored on the pins NTC1 and NTC2.

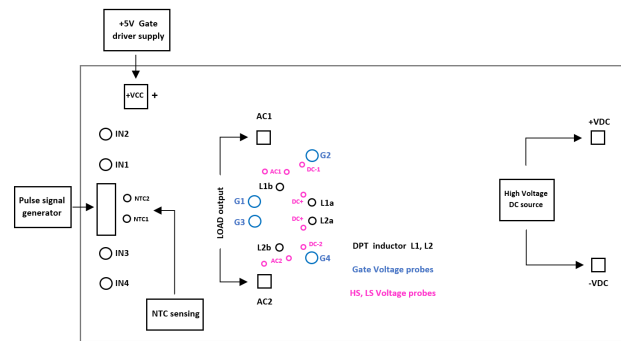

Figure 9. Board Connection

Table 2. DOUBLE PULSE TEST CONDITION

Voltage Supply V_{DC}	800 V
Drain Current I_D	> 180 A
Hotplate Temperature	$T_j = 25^{\circ}\text{C}, 125^{\circ}\text{C}, 150^{\circ}\text{C}$
Gate Voltage	$V_{GS} = 18/-3$ V
Signal Generator	10 pulse, 30 kHz, PW = 4 μs
DPT – Load Inductor	105 μH @ 30 kHz
Gate Resistor	$R_G = 3.9 \Omega$

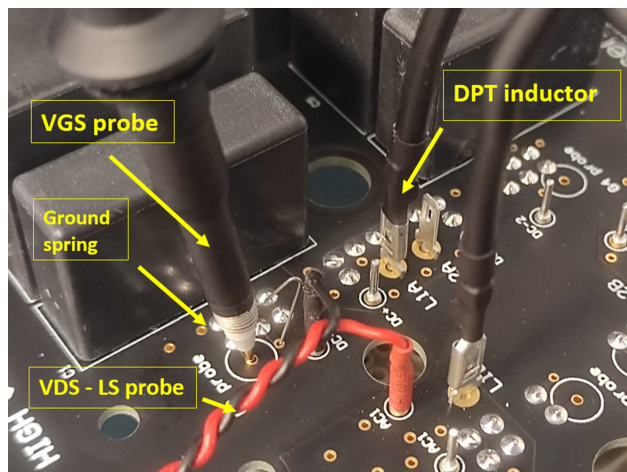

Figure 10. Double Pulse Test Probes



Figure 11. Mounting Detail Rogowski Coil to PCB

EVBUM2878G-EVB

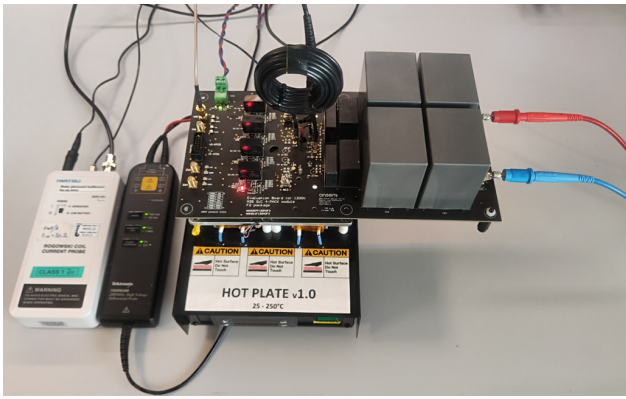

Figure 12. Double Pulse Test SETUP

Switching Waveforms, Losses

DPT test was performed with $R_G = 3R9$. The waveform does not show any large oscillations during switching. Voltage overshoot during turn is ≈ 177 V, current is ≈ 185 A.

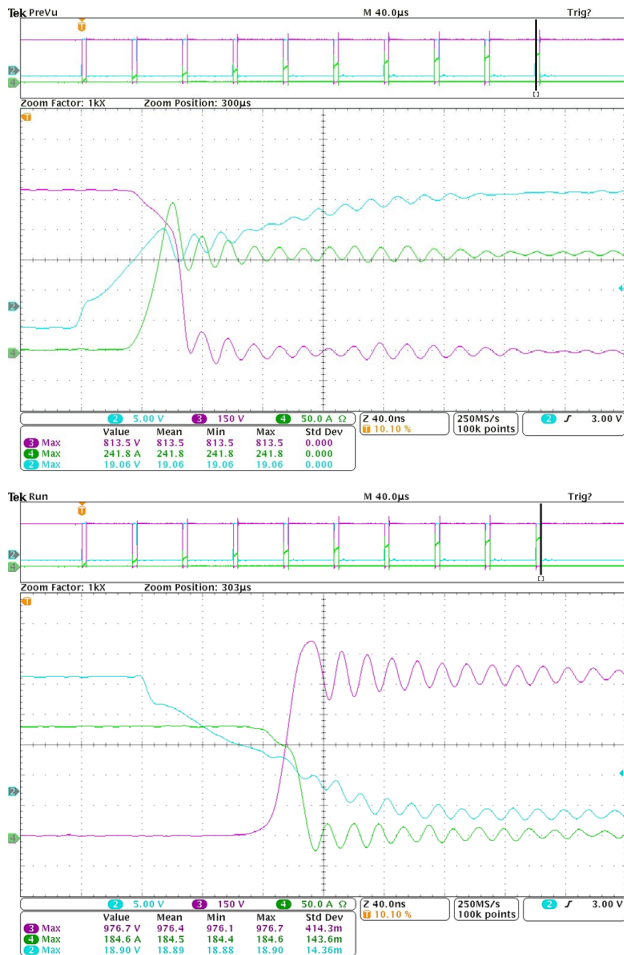

Figure 13. Turn ON, Turn OFF Typical Waveforms.

$T_j = 25^\circ\text{C}$ (Green I_D , Red V_{DS} , Blue V_{GS})

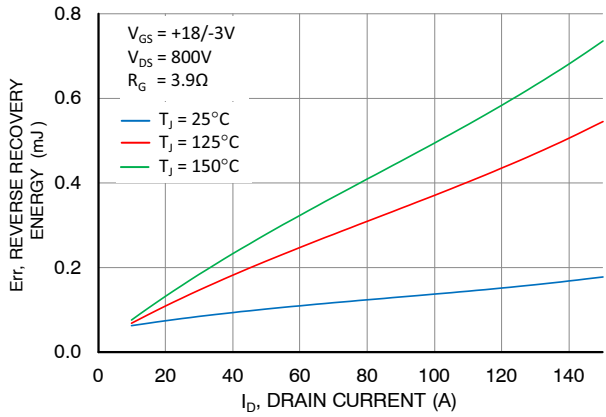
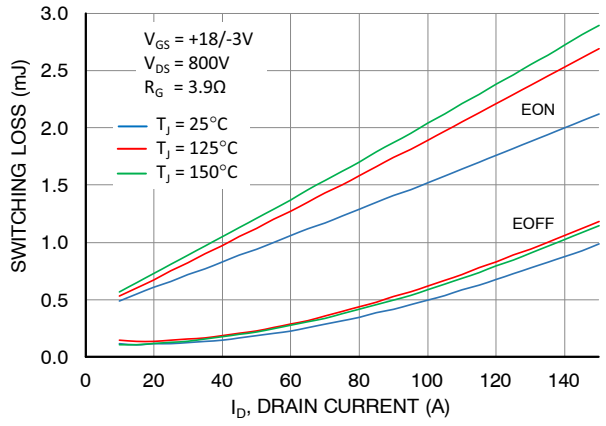

Figure 14. EON, EOFF, EERR SWITCHING LOSS for NXH011F120M3F2PTHG

2) Load Continuous Test

Load test was performed with module NXH011F120M3F2PTHG.

The module is mounted on the aluminum heatsink 25 x 20 x 5 cm, $R_{TH} = 0.2$ K/W with active cooling.

Load inductor is connected to output terminals AC1 and AC2. PWM signals were generated from a MCU board. Output was a rippled current generated by a hard switching using 30 kHz switching frequency. Evaluation Board delivered 52 A at 600 V condition, reaching NTC condition 121°C in Power Integrated Module.

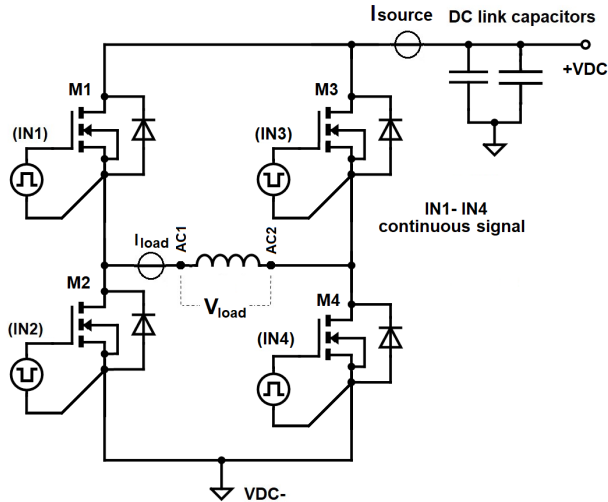

Figure 15. Load Test Schematic

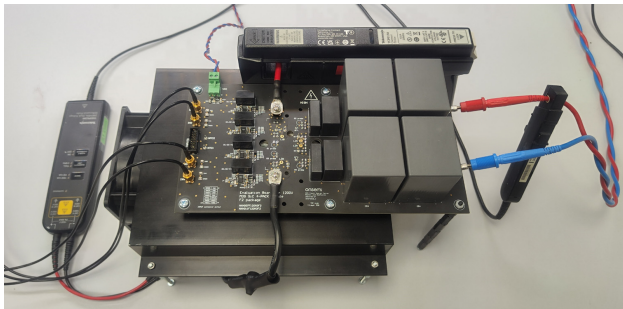

Figure 16. Load Test SETUP

Table 3. OPERATION CONDITION FOR 4PACK TEST

V_{DC} Link	600 V
I_S Current Source	685 mA
Load Current	52.3 A
POWER	31.3 kW
NTC Temperature	$\approx 121^\circ\text{C}$ (Steady State)

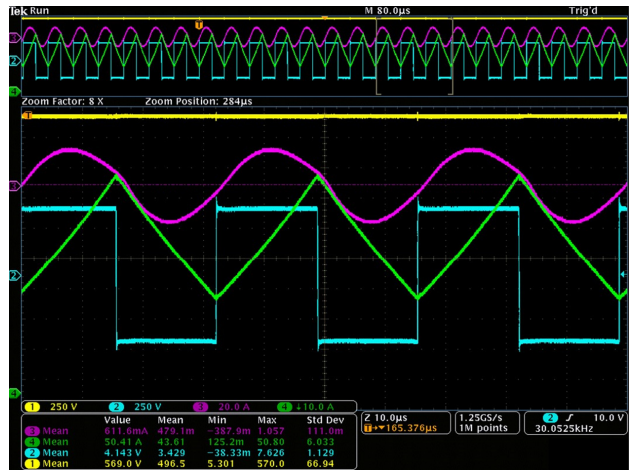

Figure 17. Oscilloscope Waveforms
(Yellow V_{DC} link, Red I_C current source, Green I_{Load} , blue V_{Load})

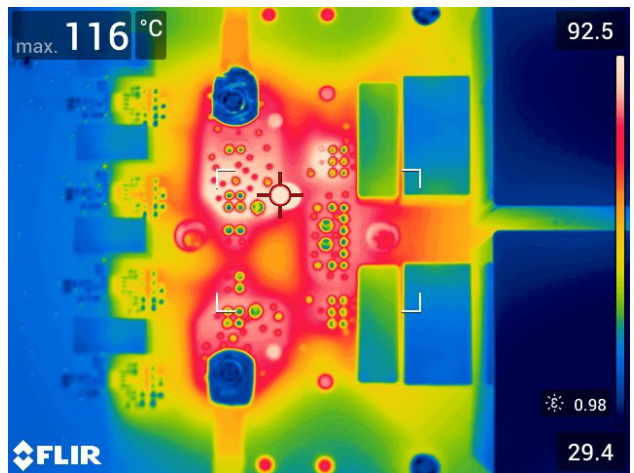

Figure 18. PCB Temperature during Operation

EVBUM2878G-EVB

SCHEMATIC

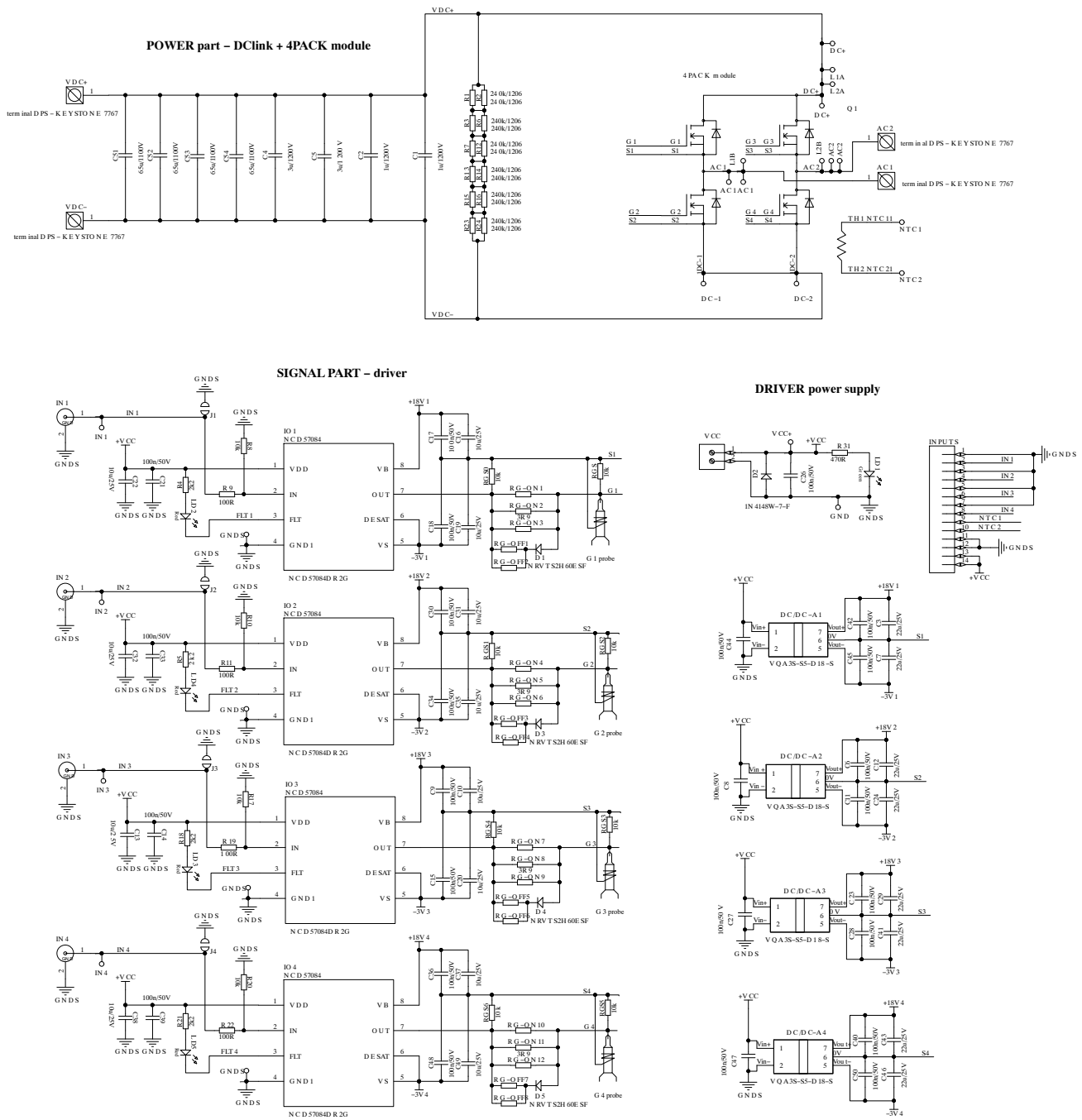

Figure 19. Complete Schematics

EVBUM2878G-EVB

LAYOUT OF EVALUATION BOARD

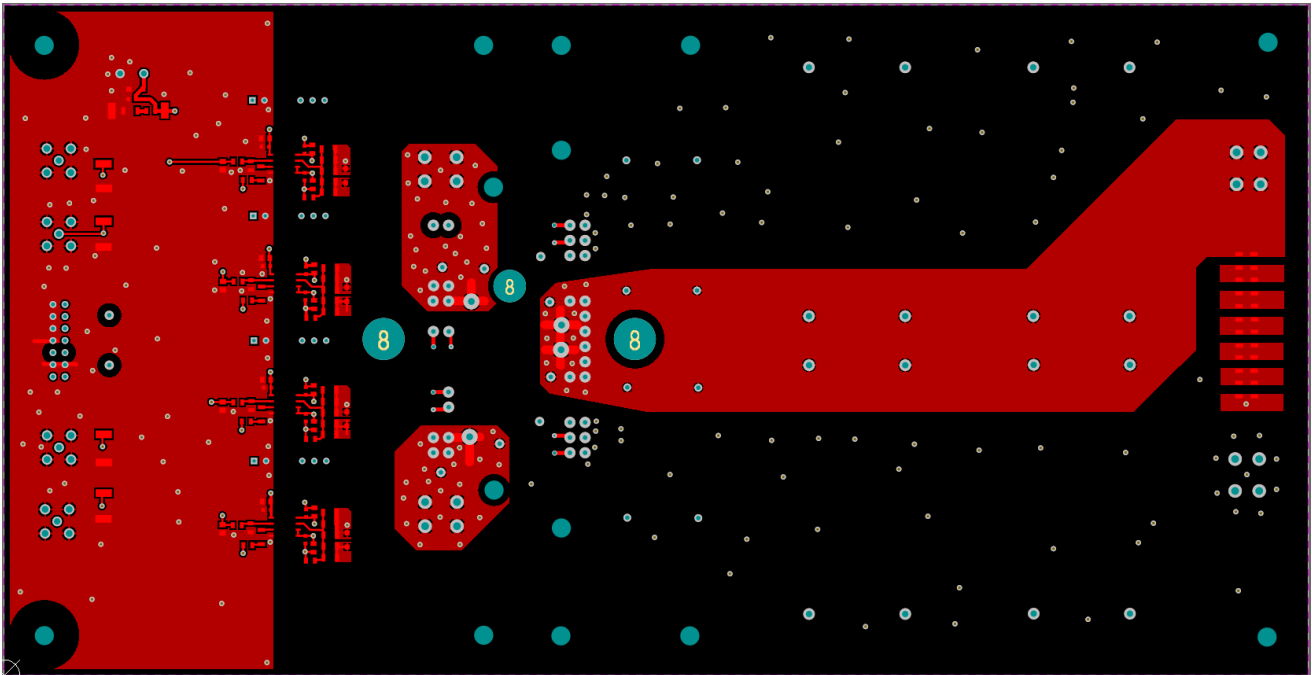

Figure 20. TOP Layer

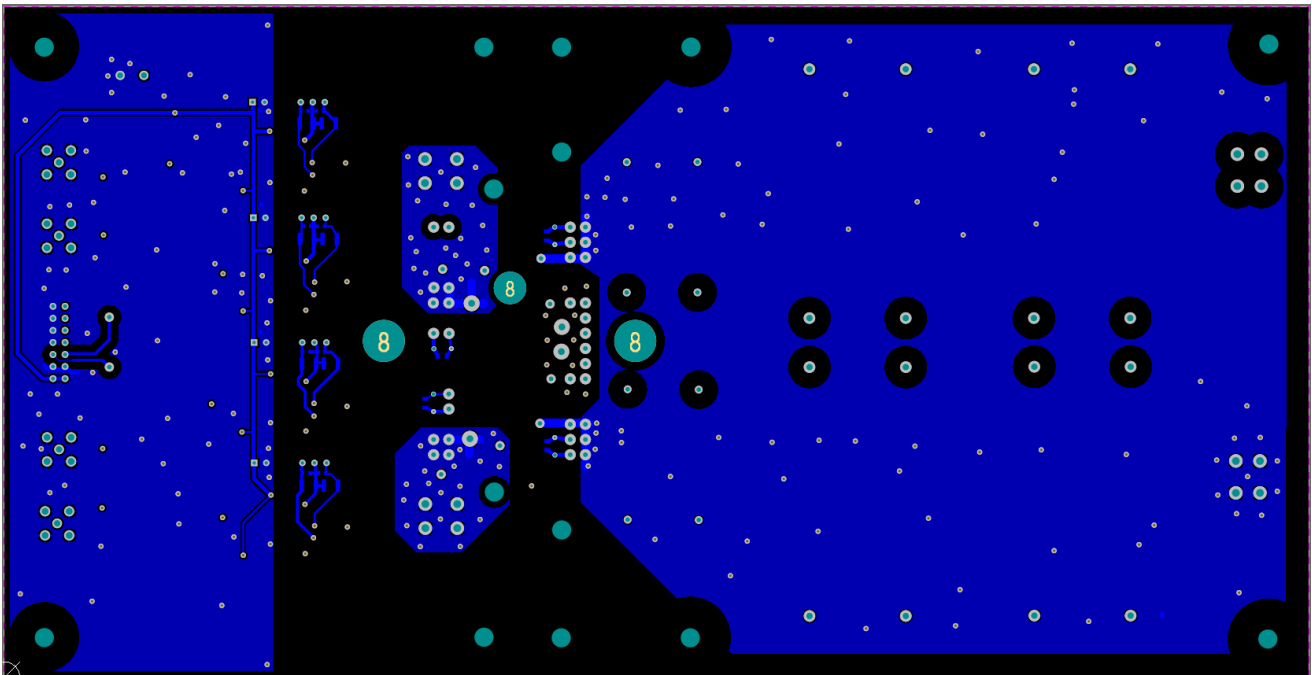

Figure 21. BOTTOM Layer

EVBUM2878G-EVB

LAYOUT OF EVALUATION BOARD (CONTINUED)

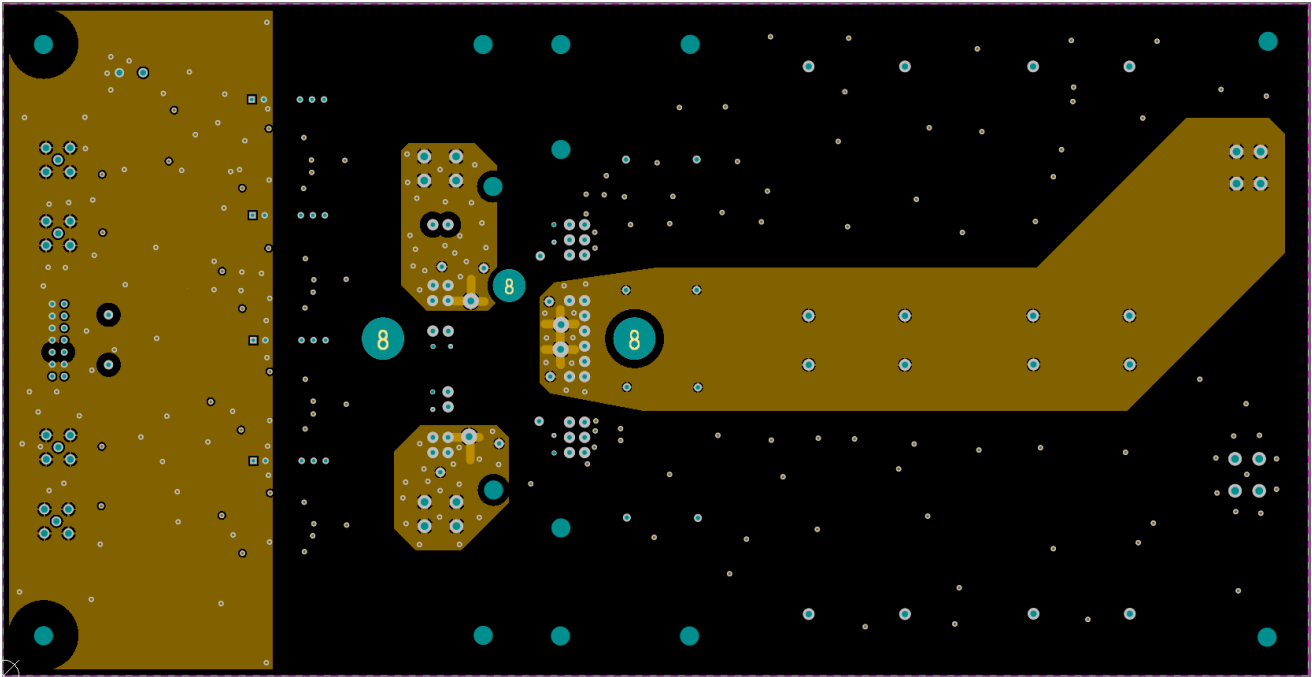

Figure 22. Signal Layer 1

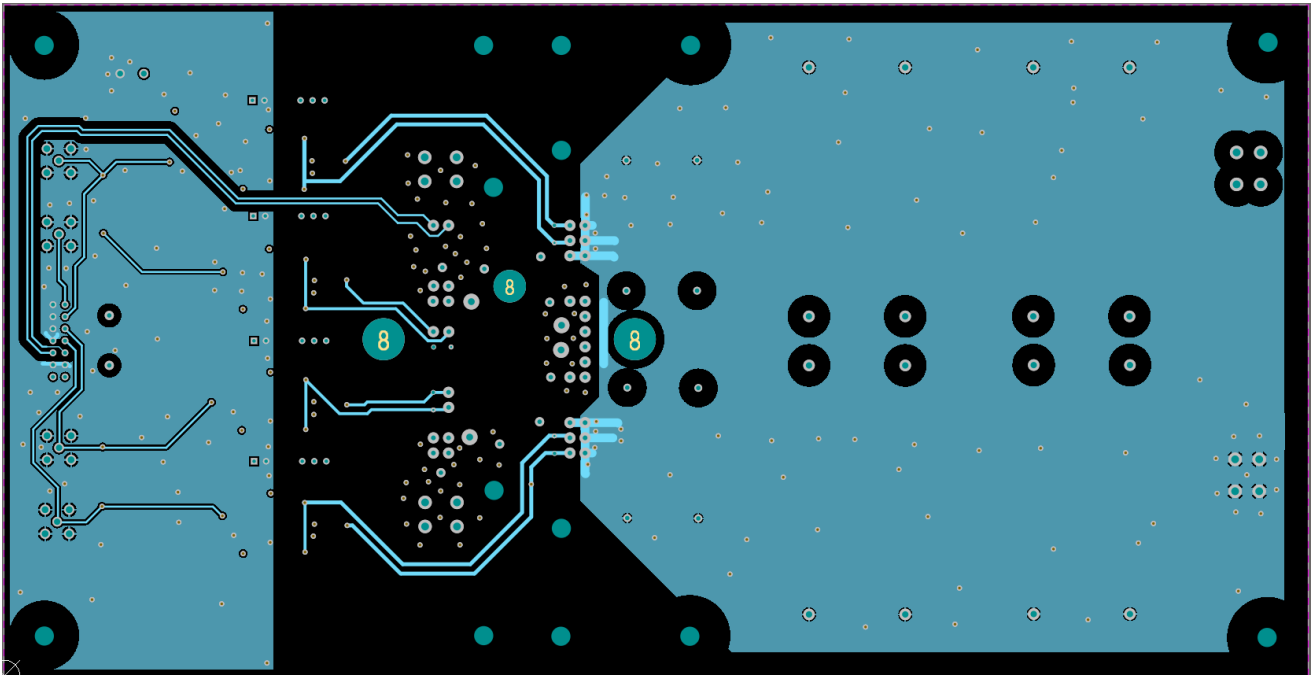

Figure 23. Signal Layer 2

EVBUM2878G-EVB

BILL OF MATERIALS

Table 4. BILL OF MATERIALS

Designator	#	Description	Value	Manufacturer Part Number
R1, R2, R3, R6, R7, R12, R13, R14, R15, R16, R23, R24	12	SMD Chip Resistor, Thick Film, AEC-Q200 WCR Series, 240 k Ω , 200 V, 250 mW	240 k Ω	TT ELECTRONICS / WELWYN WCR1206-240KFI
R4, R5, R18, R21	4	SMD Chip Resistor, 2.2 k Ω , \pm 5%, 125 mW, Thick Film	2.2 k Ω	TE CONNECTIVITY CRGCQ0805J2K2
R8, R10, R17, R20, RGS, RGS0, RGS1, RGS2, RGS3, RGS4, RGS5, RGS6	12	SMD Chip Resistor, 10 k Ω , \pm 5%, 125 mW, Thick Film	10 k Ω	MULTICOMP PRO MCHVR05JTEW1002
R9, R11, R19, R22	4	SMD Chip Resistor, 100 Ω , \pm 5%, 125 mW, Thick Film	100 Ω	MULTICOMP PRO MCSR08X101 JTL
R31	1	SMD Chip Resistor, 470 Ω , \pm 5%, 125 mW, Thick Film	470 Ω	MULTICOMP PRO MCSR08X471 JTL
RG-OFF1, RG-OFF2, RG-OFF3, RG-OFF4, RG-OFF5, RG-OFF6, RG-OFF7, RG-OFF8, RG-ON1, RG-ON3, RG-ON4, RG-ON6, RG-ON7, RG-ON9, RG-ON10, RG-ON12	16	SMD Chip Resistor with Pulse Withstanding		NOT POPULATE
RG-ON2, RG-ON5, RG-ON8, RG-ON11	4	SMD Chip Resistor, 3.9 Ω , \pm 5%, 333.3 mW, Thick Film, Pulse Withstanding	3.9 Ω	PANASONIC ERJT08J3R9V
C1, C2	2	Power Film Capacitor, Metallized PP, Radial Box - 2 Pin Through Hole	1 μ F/1200 V	VISHAY MKP1848C51012JK2
C3, C7, C12, C24, C24, C29, C41, C43, C46	8	SMD Multilayer Ceramic Capacitor, 22 μ F, 25 V, \pm 20%, X7R	22 μ F/25 V	KEMET C1210C226M3RACTU
C4, C5	2	Power Film Capacitor, Metallized PP, Radial Box - 2 Pin, Through Hole	3 μ F/1200 V	VISHAY MKP1848C53012JK2
C6, C8, C9, C11, C14, C15, C17, C18, C21, C23, C26, C27, C28, C30, C33, C34, C36, C39, C40, C42, C44, C45, C47, C48, C50	25	SMD Multilayer Ceramic Capacitor, 0.1 μ F, 50 V, \pm 10%, X7R	100 nF/50 V	WURTH ELEKTRONIK 885012206095
C10, C13, C16, C19, C20, C22, C31, C32, C35, C37, C38, C49	12	SMD Multilayer Ceramic Capacitor, 10 μ F, 25 V, \pm 10%, X7S	10 μ F/25 V	TDK C2012X7S1E106K125AC
C51, C52, C53, C54	4	Power Film Capacitor, Metallized PP, Radial Box - 4 Pin, Through Hole	45 μ F/1200 V	C4AQPEW5450M3BJ
D1, D3, D4, D5	4	Trench Schottky Rectifier, Very Low Leakage 2 A, 60 V	-	onsemi NRVTS2H60ESF
D2	1	Small Signal Diode, Single, 100 V, 300 mA, 1.25 V, 4 ns, 2 A	-	DIODES INC. 1N4148W-7-F
DC/DC-A1, DC/DC-A2, DC/DC-A3, DC/DC-A4	4	Isolated Through Hole DC/DC Converter, ITE, 1:1, 2 Output, 18 V, 80 mA	-	CUI VQA3S-S5-D18-S
IO1, IO2, IO3, IO4	4	Isolated Compact IGBT/SiC Gate Driver	-	onsemi NCD57084DR2G
LD2, LD3, LD4, LD5	4	LED, Red, SMD 1206, 20 mA, 2.1 V, 633 nm	-	DIALIGHT 599-0210-007F
LD1	1	LED, Yellow Green, SMD 1206, 20 mA, 2.1 V, 569 nm	-	DIALIGHT 599-0260-007F

EVBUM2878G-EVB

Table 4. BILL OF MATERIALS (continued)

Designator	#	Description	Value	Manufacturer Part Number
VCC CON	1	Terminal Block, Header, Plug, 5 mm, 2 Ways, 20 A, 320 V, Through Hole Right Angle	-	CAMDENBOSS CTB9350/2A
IN1, IN2, IN3, IN4	4	RF / Coaxial Connector, SMA Coaxial, Straight Jack, Solder, 50 Ω, RG174	-	LPRS SMA CONNECTOR
INPUTS CON	1	Pin Header, Board-to-Board, 2.54 mm, 2 Rows, 14 Contacts, Through Hole Straight	-	3M 30314-6002HB
AC1, AC2, DC+, NTC1, NTC2, DC-1, DC-2	10	Terminal PIN 1mm 13.14.119	-	ETTINGER 013.14.119
L1A, L1B, L2A, L2B	4	PCB Terminal, 2.8mm x 0.51mm, 0.11" x 0.02", Brass, 1.4 mm, Tin	-	AMP TE CONNECTIVITY 0-0735187-2
AC1, AC2, VDC-, VDC+	4	Screw terminal PCB, M3.5, Sn, 69843	-	DEGSON K14-00A
GND, GNDS, IN1, IN2, IN3, IN4, VCC+	10	PCB Test Point, S1751 Series, Surface Mount, Brass, Tin Plated Contacts	-	HARWIN S1751-46
4-PACK module	1	Full SiC onsemi 4PACK module	-	NXH007F120M3F2 NXH011F120M3F2
Socket pin – DC/DC Converter	20	PCB spring Socket, dimension 1.27 mm, Gold Plated Contacts	-	AMP TE CONNECTIVITY 5050462-2
Socket pin – onsemi Module	34	2 mm socket, solder connection, to 1 mm pressfit	-	Stäubli 41.0001
PCB	1	FR4 Tg 135°C (ISOLA De104), thickness 2 mm, Copper 70/70/70/70 μm, TOP/BOT mask BLACK, TOP/BOT labels WHITE, Final Surface HAL PbSn	-	RA0725EB_0
Plastic fasteners	6	Plastic Fasteners – Standoff, Nylon 6.6 (Polyamide 6.6), M4, Hex Male-Female, 25 mm, 33 mm	-	WURTH ELEKTRONIK 971250485
Plastic nuts	6	Plastic nuts – Nylon 6.6, M4 Thread Size, 7 mm Width, 2.40 mm Thickness, WA-SNTE Series	-	WURTH ELEKTRONIK 709940400

onsemi, **Onsemi**, and other names, marks, and brands are registered and/or common law trademarks of Semiconductor Components Industries, LLC dba "**onsemi**" or its affiliates and/or subsidiaries in the United States and/or other countries. **onsemi** owns the rights to a number of patents, trademarks, copyrights, trade secrets, and other intellectual property. A listing of **onsemi**'s product/patent coverage may be accessed at www.onsemi.com/site/pdf/Patent-Marking.pdf. **onsemi** is an Equal Opportunity/Affirmative Action Employer. This literature is subject to all applicable copyright laws and is not for resale in any manner.

The evaluation board/kit (research and development board/kit) (hereinafter the "board") is not a finished product and is not available for sale to consumers. The board is only intended for research, development, demonstration and evaluation purposes and will only be used in laboratory/development areas by persons with an engineering/technical training and familiar with the risks associated with handling electrical/mechanical components, systems and subsystems. This person assumes full responsibility/liability for proper and safe handling. Any other use, resale or redistribution for any other purpose is strictly prohibited.

THE BOARD IS PROVIDED BY ONSEMI TO YOU "AS IS" AND WITHOUT ANY REPRESENTATIONS OR WARRANTIES WHATSOEVER. WITHOUT LIMITING THE FOREGOING, ONSEMI (AND ITS LICENSORS/SUPPLIERS) HEREBY DISCLAIMS ANY AND ALL REPRESENTATIONS AND WARRANTIES IN RELATION TO THE BOARD, ANY MODIFICATIONS, OR THIS AGREEMENT, WHETHER EXPRESS, IMPLIED, STATUTORY OR OTHERWISE, INCLUDING WITHOUT LIMITATION ANY AND ALL REPRESENTATIONS AND WARRANTIES OF MERCHANTABILITY, FITNESS FOR A PARTICULAR PURPOSE, TITLE, NON-INFRINGEMENT, AND THOSE ARISING FROM A COURSE OF DEALING, TRADE USAGE, TRADE CUSTOM OR TRADE PRACTICE.

onsemi reserves the right to make changes without further notice to any board.

You are responsible for determining whether the board will be suitable for your intended use or application or will achieve your intended results. Prior to using or distributing any systems that have been evaluated, designed or tested using the board, you agree to test and validate your design to confirm the functionality for your application. Any technical, applications or design information or advice, quality characterization, reliability data or other services provided by **onsemi** shall not constitute any representation or warranty by **onsemi**, and no additional obligations or liabilities shall arise from **onsemi** having provided such information or services.

onsemi products including the boards are not designed, intended, or authorized for use in life support systems, or any FDA Class 3 medical devices or medical devices with a similar or equivalent classification in a foreign jurisdiction, or any devices intended for implantation in the human body. You agree to indemnify, defend and hold harmless **onsemi**, its directors, officers, employees, representatives, agents, subsidiaries, affiliates, distributors, and assigns, against any and all liabilities, losses, costs, damages, judgments, and expenses, arising out of any claim, demand, investigation, lawsuit, regulatory action or cause of action arising out of or associated with any unauthorized use, even if such claim alleges that **onsemi** was negligent regarding the design or manufacture of any products and/or the board.

This evaluation board/kit does not fall within the scope of the European Union directives regarding electromagnetic compatibility, restricted substances (RoHS), recycling (WEEE), FCC, CE or UL, and may not meet the technical requirements of these or other related directives.

FCC WARNING – This evaluation board/kit is intended for use for engineering development, demonstration, or evaluation purposes only and is not considered by **onsemi** to be a finished end product fit for general consumer use. It may generate, use, or radiate radio frequency energy and has not been tested for compliance with the limits of computing devices pursuant to part 15 of FCC rules, which are designed to provide reasonable protection against radio frequency interference. Operation of this equipment may cause interference with radio communications, in which case the user shall be responsible, at its expense, to take whatever measures may be required to correct this interference.

onsemi does not convey any license under its patent rights nor the rights of others.

LIMITATIONS OF LIABILITY: **onsemi** shall not be liable for any special, consequential, incidental, indirect or punitive damages, including, but not limited to the costs of requalification, delay, loss of profits or goodwill, arising out of or in connection with the board, even if **onsemi** is advised of the possibility of such damages. In no event shall **onsemi**'s aggregate liability from any obligation arising out of or in connection with the board, under any theory of liability, exceed the purchase price paid for the board, if any.

The board is provided to you subject to the license and other terms per **onsemi**'s standard terms and conditions of sale. For more information and documentation, please visit www.onsemi.com.

ADDITIONAL INFORMATION

TECHNICAL PUBLICATIONS:

Technical Library: www.onsemi.com/design/resources/technical-documentation
onsemi Website: www.onsemi.com

ONLINE SUPPORT: www.onsemi.com/support

For additional information, please contact your local Sales Representative at www.onsemi.com/support/sales