

# Silicon Carbide (SiC) Combo JFET – EliteSiC, Power N-Channel, H-PDSO-F8, 750 V, 5.4 mohm

## UG4SC075005L8S

### Description

onsemi's UG4SC075005L8S "Combo-FET" integrates both a 750 V SiC JFET and a Low Voltage Si MOSFET into a single H-PDSO-F8 package. This innovative approach allows users to create circuitry that would enable a normally-off switch while leveraging the benefits of a normally-on SiC JFET. These benefits include ultra-low on-resistance ( $R_{DS(on)}$ ) to minimize conduction losses and the exceptional robustness characteristic of a simplified JFET device structure, making it capable of handling the high-energy switching required in circuit protection applications. For switch-mode power conversion application, this device provides separate access to the JFET and MOSFET gates for improved speed control and ease of paralleling multiple devices.

### Features

- Single Digit  $R_{DS(on)}$
- Normally-off Capability
- Improved Speed Control
- Improved Parallel Device Operation (3+ FETs)
- Operating Temperature: 175 °C (Max)
- High Pulse Current Capability
- Excellent Device Robustness
- Silver-Sintered Die Attach for Excellent Thermal Resistance
- Short Circuit Rated
- This Device is Pb-Free, Halogen Free and is RoHS Compliant

### Typical Applications

- Solid State / Semiconductor Circuit Breaker
- Solid State / Semiconductor Relay
- Battery Disconnects
- Surge Protection
- Inrush Current Control
- High Power Switch Mode Converters (>25 kW)

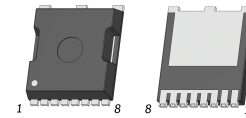

H-PDSO-F8  
CASE 740AA

### MARKING DIAGRAM

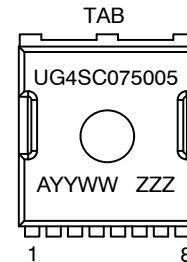

UG4SC075005	= Specific Device Number
A	= Assembly Location
YY	= Year
WW	= Work Week
ZZZ	= Lot ID

### PIN CONNECTIONS

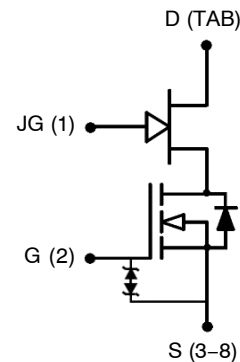

### ORDERING INFORMATION

See detailed ordering and shipping information on page 8 of this data sheet.

# UG4SC075005L8S

## MAXIMUM RATINGS

Symbol	Parameter	Test Conditions	Value	Unit
$V_{DS}$	Drain-Source Voltage		750	V
$V_{JGS}$	JFET Gate (JG) to Source Voltage	DC	-30 to +3	V
		AC (Note 1)	-30 to +30	V
$V_{GS}$	MOSFET Gate (G) to Source Voltage	DC	-20 to +20	V
		AC (f > 1 Hz)	-25 to +25	V
$I_D$	Continuous Drain Current (Note 2)	$T_C < 144\text{ }^\circ\text{C}$	120	A
$I_{DM}$	Pulsed Drain Current (Note 3)	$T_C = 25\text{ }^\circ\text{C}$	588	A
$E_{AS}$	Single Pulsed Avalanche Energy (Note 4)	L = 15 mH, $I_{AS} = 6.5\text{ A}$	316	mJ
$t_{SC}$	Short Circuit Withstand Time	$V_{DS} = 400\text{ V}$ , $T_{J(START)} = 175\text{ }^\circ\text{C}$	5	$\mu\text{S}$
dv/dt	SiC FET dv/dt Ruggedness	$V_{DS} < 500\text{ V}$	100	V/ns
$P_{tot}$	Power Dissipation	$T_C = 25\text{ }^\circ\text{C}$	1153	W
$T_{J,max}$	Maximum Junction Temperature		175	$^\circ\text{C}$
$T_J$ , $T_{STG}$	Operating and Storage Temperature		-55 to 175	$^\circ\text{C}$
$T_{solder}$	Reflow Soldering Temperature	Reflow MSL 1	260	$^\circ\text{C}$

Stresses exceeding those listed in the Maximum Ratings table may damage the device. If any of these limits are exceeded, device functionality should not be assumed, damage may occur and reliability may be affected.

- +30 V AC rating applies for turn-on pulses < 200 ns applied with external  $R_G > 1\ \Omega$ .
- Limited by Bondwires
- Pulse width  $t_p$  limited by  $T_{J,max}$ .
- Starting  $T_J = 25\text{ }^\circ\text{C}$

## THERMAL CHARACTERISTICS

Symbol	Parameter	Test Conditions	Min	Typ	Max	Unit
$R_{\theta JC}$	Thermal Resistance, Junction-to-Case		-	0.10	0.13	$^\circ\text{C/W}$

## ELECTRICAL CHARACTERISTICS ( $T_J = +25\text{ }^\circ\text{C}$ and $V_{JGS} = 0\text{ V}$ unless otherwise specified)

Symbol	Parameter	Test Conditions	Min	Typ	Max	Unit
--------	-----------	-----------------	-----	-----	-----	------

### TYPICAL PERFORMANCE - STATIC

$BV_{DS}$	Drain-Source Breakdown Voltage	$V_{GS} = 0\text{ V}$ , $I_D = 1\text{ mA}$	750	-	-	V
$I_{DSS}$	Total Drain Leakage Current	$V_{DS} = 750\text{ V}$ , $V_{GS} = 0\text{ V}$ , $T_J = 25\text{ }^\circ\text{C}$	-	6	130	$\mu\text{A}$
		$V_{DS} = 750\text{ V}$ , $V_{GS} = 0\text{ V}$ , $T_J = 175\text{ }^\circ\text{C}$	-	45	-	
$I_{JGSS}$	Total JFET Gate Leakage Current	$V_{GS} = -20\text{ V}$ , $V_{GS} = 12\text{ V}$	-	0.1	100	$\mu\text{A}$
$I_{GSS}$	Total MOSFET Gate Leakage Current	$V_{GS} = -20\text{ V} / +20\text{ V}$	-	6	20	$\mu\text{A}$
$R_{DS(on)}$	Drain-Source On-resistance	$V_{GS} = 15\text{ V}$ , $V_{JGS} = 2\text{ V}$ , $I_D = 80\text{ A}$ , $T_J = 25\text{ }^\circ\text{C}$	-	5.0	-	m $\Omega$
		$V_{GS} = 15\text{ V}$ , $V_{JGS} = 0\text{ V}$ , $I_D = 80\text{ A}$ , $T_J = 25\text{ }^\circ\text{C}$	-	5.4	7.2	
		$V_{GS} = 15\text{ V}$ , $V_{JGS} = 0\text{ V}$ , $I_D = 80\text{ A}$ , $T_J = 125\text{ }^\circ\text{C}$	-	9.3	-	
		$V_{GS} = 15\text{ V}$ , $V_{JGS} = 0\text{ V}$ , $I_D = 80\text{ A}$ , $T_J = 175\text{ }^\circ\text{C}$	-	12.2	-	
$V_{JG(th)}$	JFET Gate Threshold Voltage	$V_{DS} = 5\text{ V}$ , $V_{GS} = 12\text{ V}$ , $I_D = 180\text{ mA}$	-8.3	-6.0	-3.7	V
$V_{G(th)}$	MOSFET Gate Threshold Voltage	$V_{DS} = 5\text{ V}$ , $I_D = 10\text{ mA}$	4	4.7	6	V
$R_{JG}$	JFET Gate Resistance	f = 1 MHz, open drain	-	0.8	-	$\Omega$
$R_G$	MOSFET Gate Resistance	f = 1 MHz, open drain	-	0.8	-	$\Omega$

# UG4SC075005L8S

## ELECTRICAL CHARACTERISTICS ( $T_J = +25\text{ }^\circ\text{C}$ and $V_{JGS} = 0\text{ V}$ unless otherwise specified) (continued)

Symbol	Parameter	Test Conditions	Min	Typ	Max	Unit
--------	-----------	-----------------	-----	-----	-----	------

### TYPICAL PERFORMANCE - REVERSE DIODE

$I_S$	Diode Continuous Forward Current (Note 1)	$T_C < 144\text{ }^\circ\text{C}$	-	-	120	A
$I_{S,pulse}$	Diode Pulse Current (Note 2)	$T_C = 25\text{ }^\circ\text{C}$	-	-	588	A
$V_{FSD}$	Forward Voltage	$V_{DS} = 0\text{ V}, I_S = 50\text{ A}, T_J = 25\text{ }^\circ\text{C}$	-	1.03	1.16	V
		$V_{DS} = 0\text{ V}, I_S = 50\text{ A}, T_J = 175\text{ }^\circ\text{C}$	-	1.06	-	
$Q_{rr}$	Reverse Recovery Charge	$V_{DS} = 400\text{ V}, I_S = 80\text{ A},$ $V_{GS} = 0\text{ V}, V_{JGS} = 0\text{ V},$ $R_{JG} = 0.7\ \Omega,$ $di/dt = 2400\text{ A}/\mu\text{s}, T_J = 25\text{ }^\circ\text{C}$	-	377	-	nC
$t_{rr}$	Reverse Recovery Time	$V_{DS} = 400\text{ V}, I_S = 80\text{ A},$ $V_{GS} = 0\text{ V}, V_{JGS} = 0\text{ V},$ $R_{JG} = 0.7\ \Omega,$ $di/dt = 2400\text{ A}/\mu\text{s}, T_J = 25\text{ }^\circ\text{C}$	-	70	-	ns
$Q_{rr}$	Reverse Recovery Charge	$V_{DS} = 400\text{ V}, I_S = 80\text{ A},$ $V_{GS} = 0\text{ V}, V_{JGS} = 0\text{ V},$ $R_{JG} = 0.7\ \Omega,$ $di/dt = 2400\text{ A}/\mu\text{s}, T_J = 150\text{ }^\circ\text{C}$	-	427	-	nC
$t_{rr}$	Reverse Recovery Time	$V_{DS} = 400\text{ V}, I_S = 80\text{ A},$ $V_{GS} = 0\text{ V}, V_{JGS} = 0\text{ V},$ $R_{JG} = 0.7\ \Omega,$ $di/dt = 2400\text{ A}/\mu\text{s}, T_J = 150\text{ }^\circ\text{C}$	-	78	-	ns

### TYPICAL PERFORMANCE - DYNAMIC WITH MOSFET GATE AS CONTROL TERMINAL AND $V_{JGS} = 0\text{ V}$

$C_{iss}$	MOSFET Input Capacitance	$V_{DS} = 400\text{ V}, V_{GS} = 0\text{ V},$ $f = 100\text{ kHz}$	-	8374	-	pF
$C_{oss}$	Output Capacitance		-	362	-	
$C_{riss}$	Reverse Transfer Capacitance		-	4	-	
$C_{oss(er)}$	Effective Output Capacitance, Energy Related	$V_{DS} = 0\text{ V to } 400\text{ V}, V_{GS} = 0\text{ V}$	-	475	-	pF
$C_{oss(tr)}$	Effective Output Capacitance, Time Related		-	950	-	pF
$Q_G$	Total Gate Charge	$V_{DS} = 400\text{ V}, I_D = 80\text{ A},$ $V_{GS} = 0\text{ V to } 15\text{ V}$	-	164	-	nC
$Q_{GD}$	Gate-Drain Charge		-	24	-	
$Q_{GS}$	Gate-Source Charge		-	46	-	

### TYPICAL PERFORMANCE - DYNAMIC WITH JFET GATE AS CONTROL TERMINAL AND $V_{GS} = +12\text{ V}$

$C_{Jiss}$	JFET Input Capacitance	$V_{DS} = 400\text{ V}, V_{JGS} = -20\text{ V},$ $f = 100\text{ kHz}$	-	3028	-	pF
$C_{Joss}$	JFET Output Capacitance		-	364	-	
$C_{Jriss}$	JFET Reverse Transfer Capacitance		-	360	-	
$Q_{JG}$	JFET Total Gate Charge	$V_{DS} = 400\text{ V}, I_D = 80\text{ A},$ $V_{JGS} = -18\text{ V to } 0\text{ V}$	-	400	-	nC
$Q_{JGD}$	JFET Gate-drain Charge		-	270	-	
$Q_{JGS}$	JFET Gate-source Charge		-	60	-	

Product parametric performance is indicated in the Electrical Characteristics for the listed test conditions, unless otherwise noted. Product performance may not be indicated by the Electrical Characteristics if operated under different conditions.

TYPICAL PERFORMANCE DIAGRAMS - MOSFET GATE AS CONTROL TERMINAL AND  $V_{JGS} = 0\text{ V}$

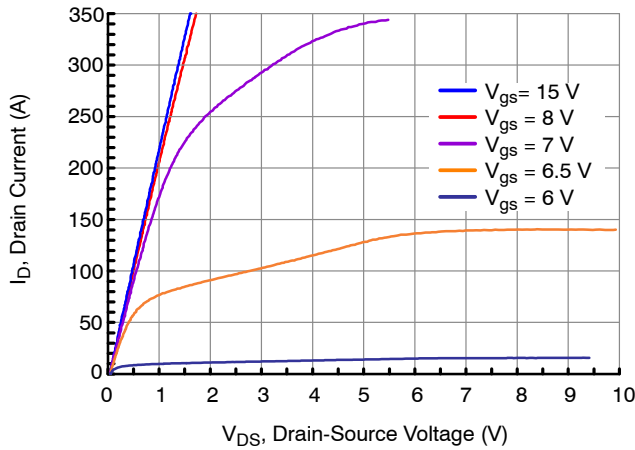

Figure 1. Typical Output Characteristics at  $T_J = -55\text{ }^\circ\text{C}$ ,  $t_p < 250\text{ }\mu\text{s}$

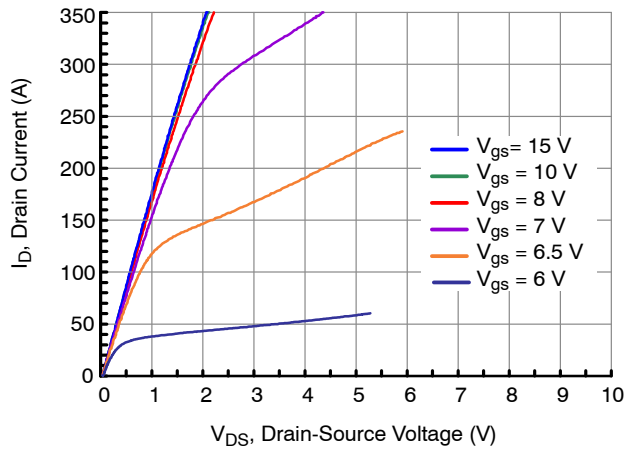

Figure 2. Typical Output Characteristics at  $T_J = 25\text{ }^\circ\text{C}$ ,  $t_p < 250\text{ }\mu\text{s}$

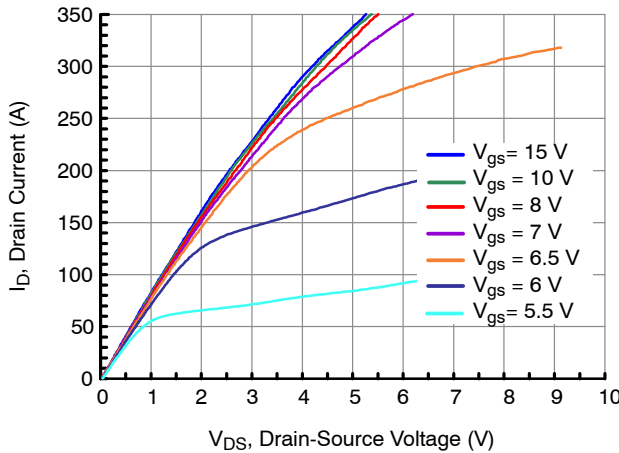

Figure 3. Typical Output Characteristics at  $T_J = 175\text{ }^\circ\text{C}$ ,  $t_p < 250\text{ }\mu\text{s}$

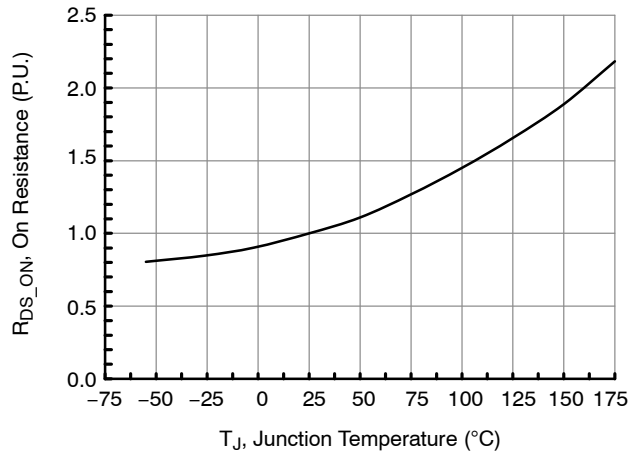

Figure 4. Normalized On-Resistance vs. Temperature at  $V_{GS} = 12\text{ V}$  and  $I_D = 80\text{ A}$

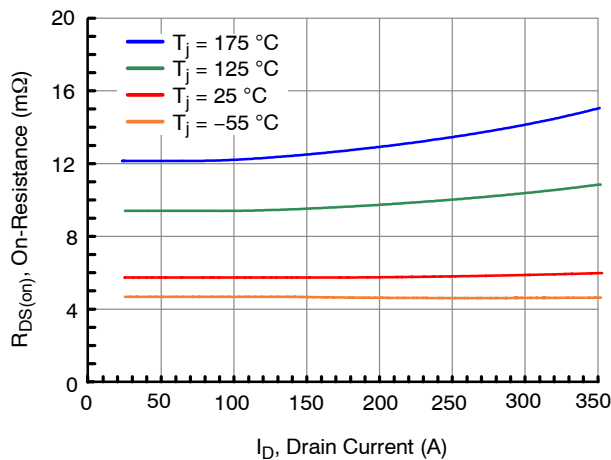

Figure 5. Typical Drain-Source On-Resistances at  $V_{GS} = 12\text{ V}$

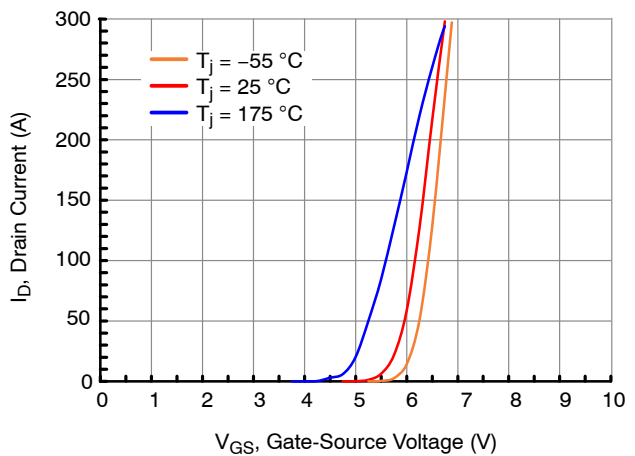

Figure 6. Typical Transfer Characteristics at  $V_{DS} = 5\text{ V}$

TYPICAL PERFORMANCE DIAGRAMS - MOSFET GATE AS CONTROL TERMINAL AND  $V_{JGS} = 0\text{ V}$

(continued)

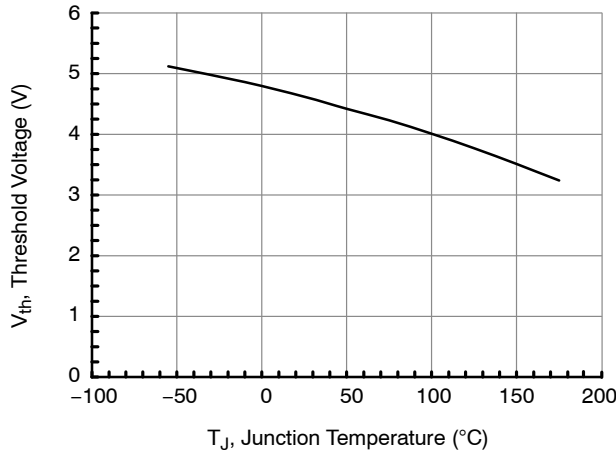

Figure 7. Threshold Voltage vs Junction Temperature at  $V_{DS} = 5\text{ V}$  and  $I_D = 10\text{ mA}$

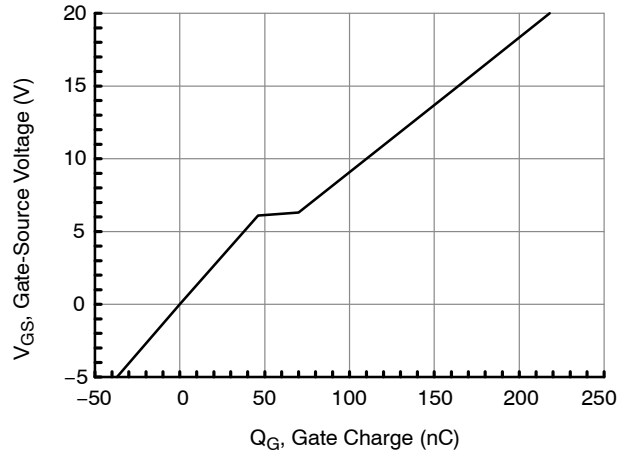

Figure 8. Typical Gate Charge at  $V_{DS} = 400\text{ V}$  and  $I_D = 80\text{ A}$

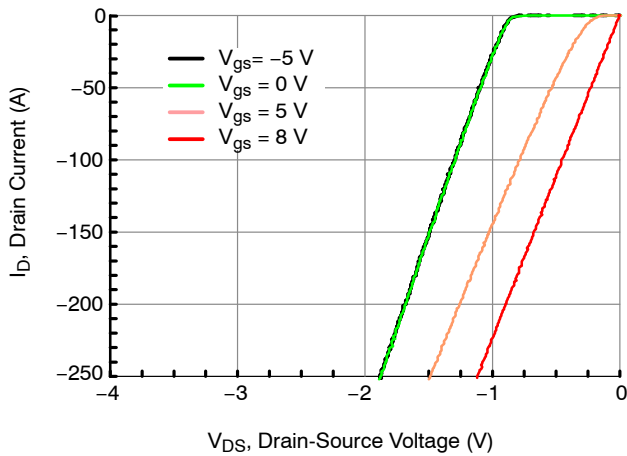

Figure 9. 3<sup>rd</sup> Quadrant Characteristics at  $T_J = -55\text{ °C}$

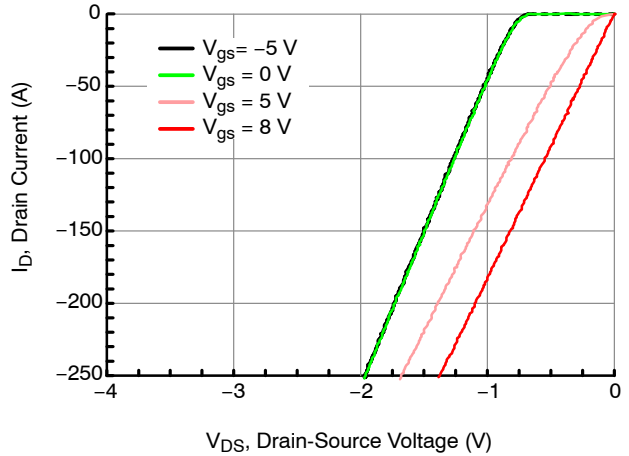

Figure 10. 3<sup>rd</sup> Quadrant Characteristics at  $T_J = 25\text{ °C}$

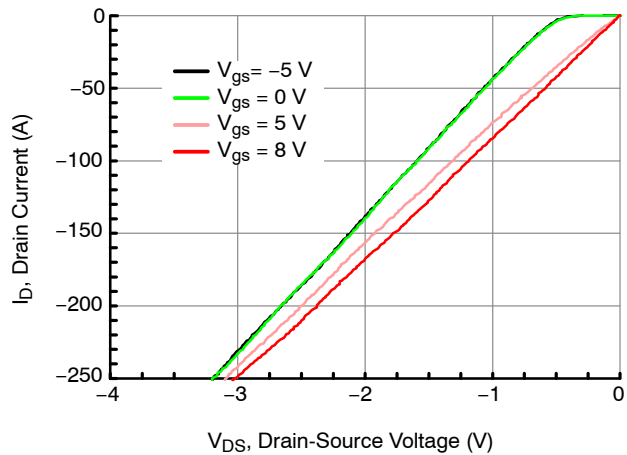

Figure 11. 3<sup>rd</sup> Quadrant Characteristics at  $T_J = 175\text{ °C}$

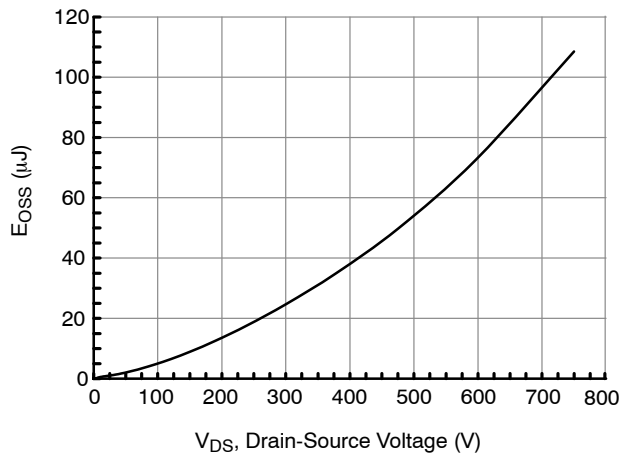
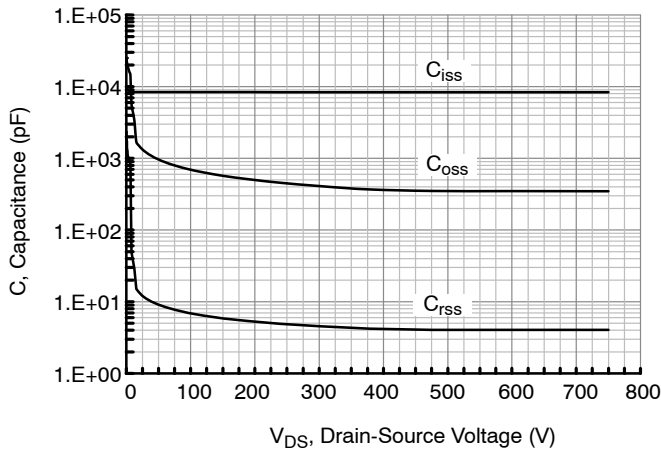

Figure 12. Typical Stored Energy in  $C_{OSS}$  at  $V_{GS} = 0\text{ V}$

# UG4SC075005L8S

## TYPICAL PERFORMANCE DIAGRAMS - MOSFET GATE AS CONTROL TERMINAL AND $V_{JGS} = 0\text{ V}$

(continued)



**Figure 13. Typical Capacitances at  $f = 100\text{ kHz}$  and  $V_{GS} = 0\text{ V}$**

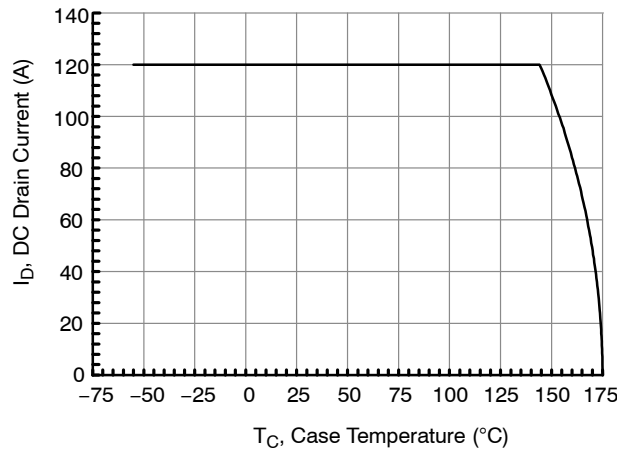

**Figure 14. DC Drain Current Derating**

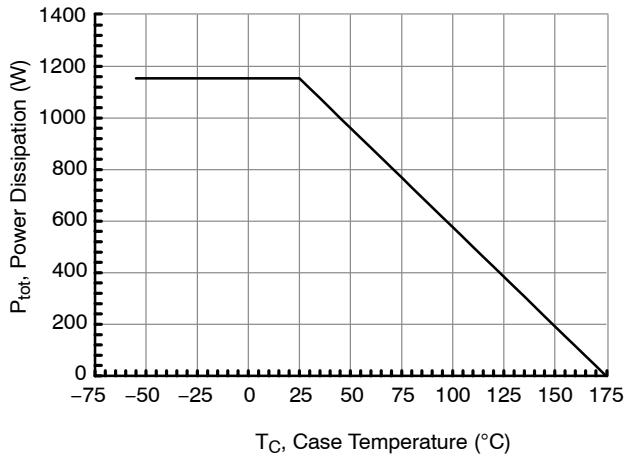

**Figure 15. Total Power Dissipation**

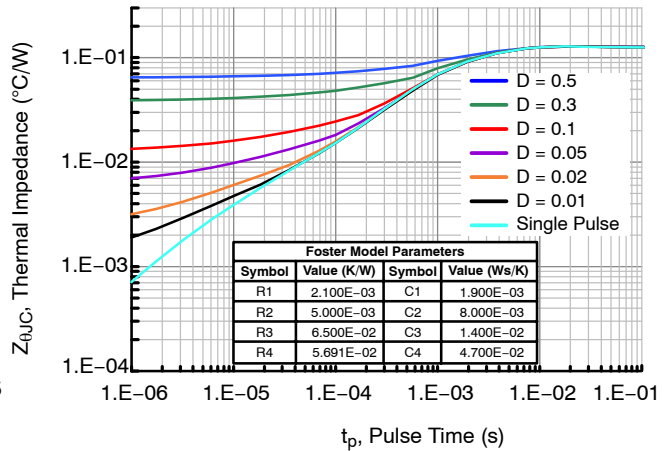

**Figure 16. Maximum Transient Thermal Impedance**

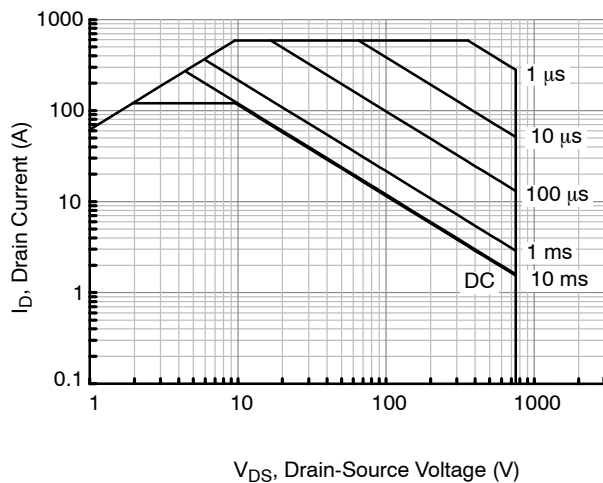

**Figure 17. Safe Operation Area at  $T_C = 25\text{ °C}$ ,  $D = 0$ , Parameter  $t_p$**

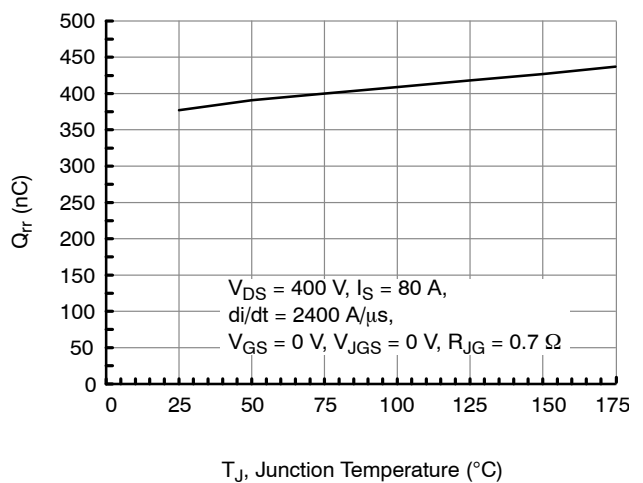

**Figure 18. Reverse Recovery Charge  $Q_{rr}$  vs. Junction Temperature**

TYPICAL PERFORMANCE DIAGRAMS - JFET GATE AS CONTROL TERMINAL AND  $V_{GS} = +12\text{ V}$

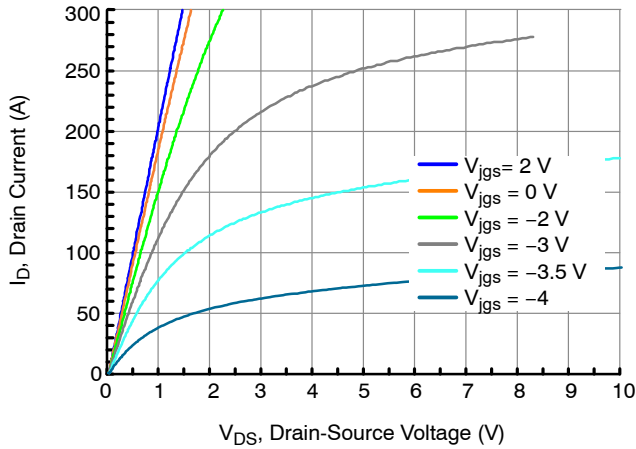

Figure 19. Typical Output Characteristics with JFET Gate as Control at  $T_J = -55\text{ }^\circ\text{C}$ ,  $t_p < 250\text{ }\mu\text{s}$

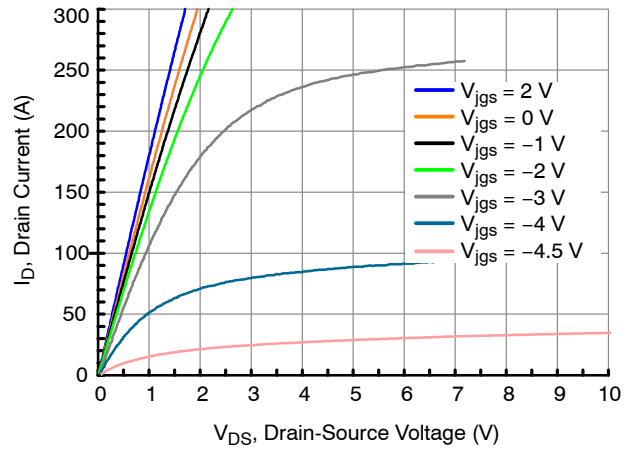

Figure 20. Typical Output Characteristics with JFET Gate as Control at  $T_J = 25\text{ }^\circ\text{C}$ ,  $t_p < 250\text{ }\mu\text{s}$

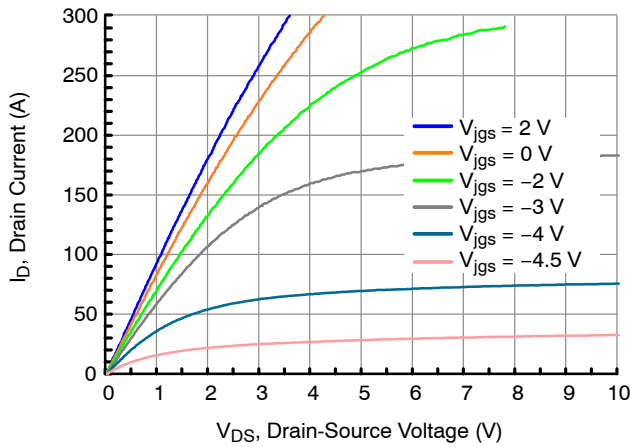

Figure 21. Typical Output Characteristics with JFET Gate as Control at  $T_J = 175\text{ }^\circ\text{C}$ ,  $t_p < 250\text{ }\mu\text{s}$

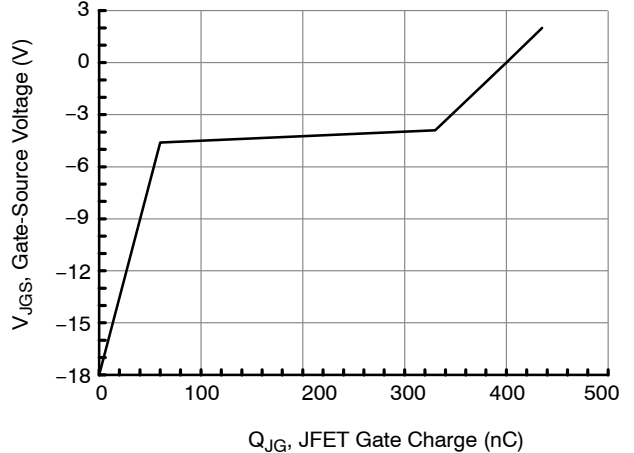

Figure 22. Typical JFET Gate Charge at  $V_{DS} = 400\text{ V}$  and  $I_D = 80\text{ A}$

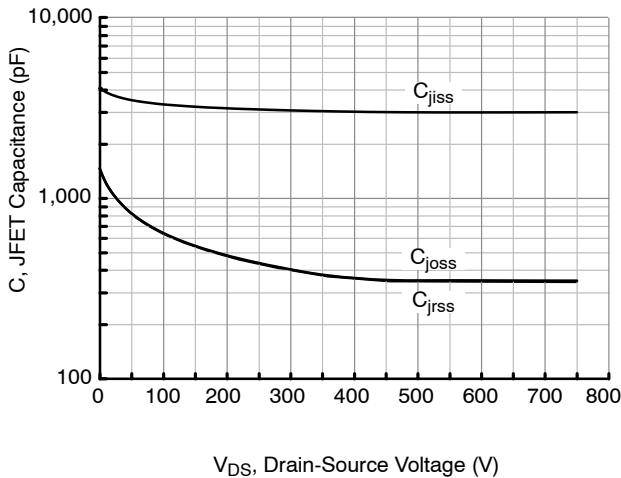

Figure 23. Typical JFET Capacitances at  $f = 100\text{ kHz}$  and  $V_{JGS} = -20\text{ V}$

# UG4SC075005L8S

## ORDERING INFORMATION

Part Number	Marking	Package	Shipping <sup>†</sup>
UG4SC075005L8S	UG4SC075005	H-PDSO-F8 (Pb-Free, Halogen Free)	2,000 / Tape and Reel

† For information on tape and reel specifications, including part orientation and tape sizes, please refer to our Tape and Reel Packaging Specifications Brochure, [BRD8011/D](#).

## REVISION HISTORY

Revision	Description of Changes	Date
B	Acquired the original Qorvo JFET Division Data Sheet and updated the main document title to comply with onsemi standards for SiC products.	1/15/2025
2	Converted the Data Sheet to <b>onsemi</b> format.	5/26/2025

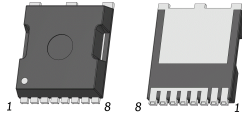

H-PDSO-F8 9.90x10.38x2.30, 1.20P  
CASE 740AA  
ISSUE B

DATE 24 JUN 2025

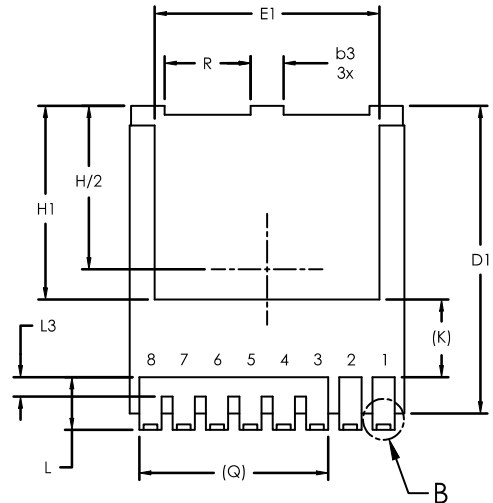
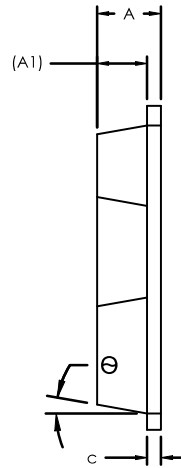
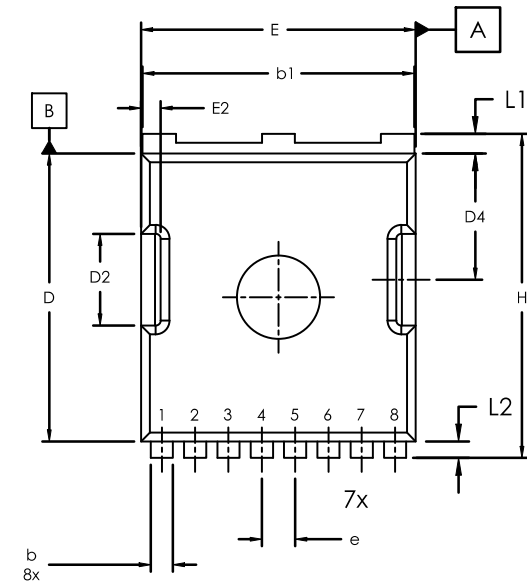

⊕	0.25(M)	C	A	B
---	---------	---	---	---

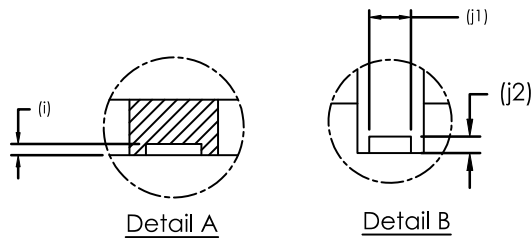
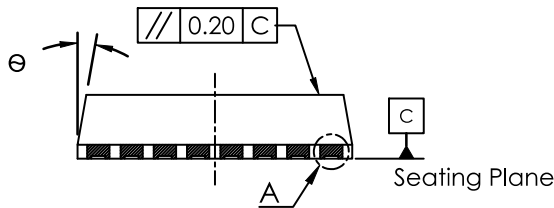

Note:

1. Dimensioning and tolerancing as per ASME Y14.5 - 2018
2. Controlling dimension : millimeters
3. Dimensions does not include Burrs and Mold Flashes

SYMBOL	Value		
	Min	Nom	Max
A	2.15	2.30	2.45
A1	1.80 REF		
b	0.65	0.80	0.90
b1	9.65	9.80	9.95
b3	1.10	1.20	1.30
c	0.40	0.50	0.60
D	10.18	10.38	10.58
D1	10.88	11.08	11.28
D2	3.15	3.30	3.45
D4	4.40	4.55	4.70
E	9.70	9.90	10.10
E1	7.95	8.10	8.25
E2	0.60	0.70	0.80
e	1.20 BSC		
H	11.48	11.68	11.88
H1	6.80	6.95	7.10
i	0.10 REF		
j1	0.46 REF		
j2	0.20 REF		
K	2.80 REF		
L	1.40	1.90	2.10
L1	0.50	0.70	0.90
L2	0.48	0.60	0.72
L3	0.30	0.70	0.80
Q	6.80 REF		
R	3.00	3.10	3.20
θ	10°		

DOCUMENT NUMBER:	98AON26704H	Electronic versions are uncontrolled except when accessed directly from the Document Repository. Printed versions are uncontrolled except when stamped "CONTROLLED COPY" in red.
DESCRIPTION:	H-PDSO-F8 9.90x10.38x2.30, 1.20P	PAGE 1 OF 2

onsemi and ONSEMI are trademarks of Semiconductor Components Industries, LLC dba onsemi or its subsidiaries in the United States and/or other countries. onsemi reserves the right to make changes without further notice to any products herein. onsemi makes no warranty, representation or guarantee regarding the suitability of its products for any particular purpose, nor does onsemi assume any liability arising out of the application or use of any product or circuit, and specifically disclaims any and all liability, including without limitation special, consequential or incidental damages. onsemi does not convey any license under its patent rights nor the rights of others.

RECOMMENDED PCB LAND PATTERN

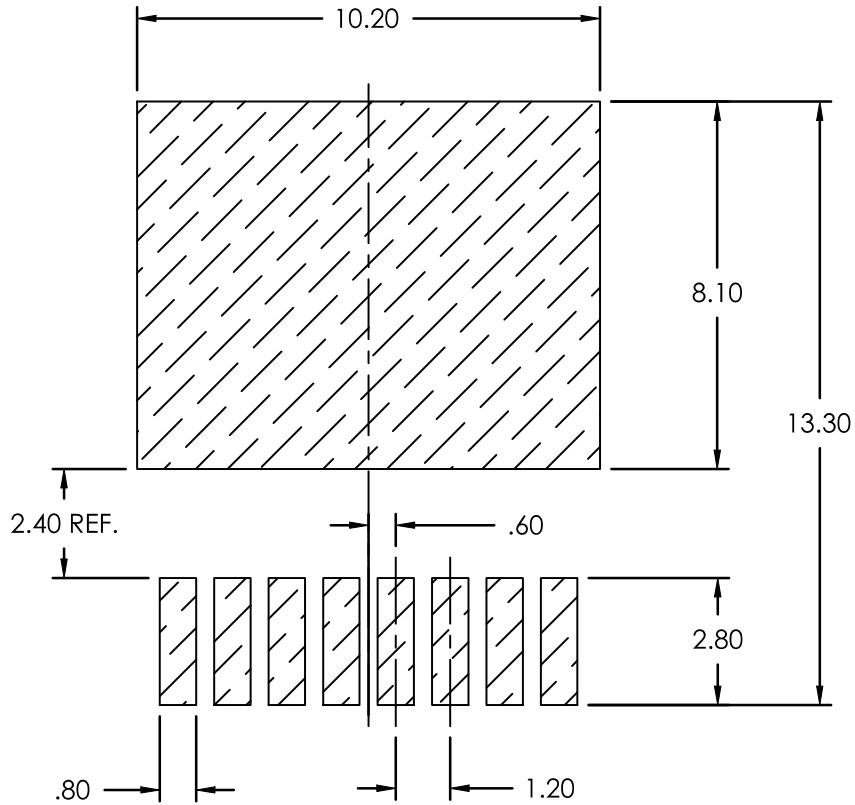

NOTE: LAND PATTERN AND THROUGH HOLE DIMENSIONS SERVE ONLY AS AN INITIAL GUIDE.  
END-USER PCB DESIGN RULES AND TOLERANCES SHOULD ALWAYS PREVAIL.

<b>DOCUMENT NUMBER:</b>	<b>98AON26704H</b>	Electronic versions are uncontrolled except when accessed directly from the Document Repository. Printed versions are uncontrolled except when stamped "CONTROLLED COPY" in red.
<b>DESCRIPTION:</b>	<b>H-PDSO-F8 9.90x10.38x2.30, 1.20P</b>	<b>PAGE 2 OF 2</b>

**onsemi** and **ONSEMI** are trademarks of Semiconductor Components Industries, LLC dba **onsemi** or its subsidiaries in the United States and/or other countries. **onsemi** reserves the right to make changes without further notice to any products herein. **onsemi** makes no warranty, representation or guarantee regarding the suitability of its products for any particular purpose, nor does **onsemi** assume any liability arising out of the application or use of any product or circuit, and specifically disclaims any and all liability, including without limitation special, consequential or incidental damages. **onsemi** does not convey any license under its patent rights nor the rights of others.

**onsemi**, **Onsemi**, and other names, marks, and brands are registered and/or common law trademarks of Semiconductor Components Industries, LLC dba "**onsemi**" or its affiliates and/or subsidiaries in the United States and/or other countries. **onsemi** owns the rights to a number of patents, trademarks, copyrights, trade secrets, and other intellectual property. A listing of **onsemi**'s product/patent coverage may be accessed at [www.onsemi.com/site/pdf/Patent-Marking.pdf](http://www.onsemi.com/site/pdf/Patent-Marking.pdf). **onsemi** reserves the right to make changes at any time to any products or information herein, without notice. The information herein is provided "as-is" and **onsemi** makes no warranty, representation or guarantee regarding the accuracy of the information, product features, availability, functionality, or suitability of its products for any particular purpose, nor does **onsemi** assume any liability arising out of the application or use of any product or circuit, and specifically disclaims any and all liability, including without limitation special, consequential or incidental damages. Buyer is responsible for its products and applications using **onsemi** products, including compliance with all laws, regulations and safety requirements or standards, regardless of any support or applications information provided by **onsemi**. "Typical" parameters which may be provided in **onsemi** data sheets and/or specifications can and do vary in different applications and actual performance may vary over time. All operating parameters, including "Typicals" must be validated for each customer application by customer's technical experts. **onsemi** does not convey any license under any of its intellectual property rights nor the rights of others. **onsemi** products are not designed, intended, or authorized for use as a critical component in life support systems or any FDA Class 3 medical devices or medical devices with a same or similar classification in a foreign jurisdiction or any devices intended for implantation in the human body. Should Buyer purchase or use **onsemi** products for any such unintended or unauthorized application, Buyer shall indemnify and hold **onsemi** and its officers, employees, subsidiaries, affiliates, and distributors harmless against all claims, costs, damages, and expenses, and reasonable attorney fees arising out of, directly or indirectly, any claim of personal injury or death associated with such unintended or unauthorized use, even if such claim alleges that **onsemi** was negligent regarding the design or manufacture of the part. **onsemi** is an Equal Opportunity/Affirmative Action Employer. This literature is subject to all applicable copyright laws and is not for resale in any manner.

## ADDITIONAL INFORMATION

### TECHNICAL PUBLICATIONS:

Technical Library: [www.onsemi.com/design/resources/technical-documentation](http://www.onsemi.com/design/resources/technical-documentation)  
onsemi Website: [www.onsemi.com](http://www.onsemi.com)

### ONLINE SUPPORT: [www.onsemi.com/support](http://www.onsemi.com/support)

For additional information, please contact your local Sales Representative at [www.onsemi.com/support/sales](http://www.onsemi.com/support/sales)

