

# Linear Regulator – 300 mA, Market Leading Transient Response Time and Ultra-Low Dropout

## T30LMPSR165

The T30LMPSR165 is an ultra-fast linear regulator capable of supplying 300 mA output current from 1.4 V input voltage. The device provides a best-in-class transient response time (0.8  $\mu$ s, typ.) suitable for applications with fast sampling rate. The device features an ultra-low dropout voltage (26 mV at 300 mA) enabling higher efficiency while offering wide output voltage range (1.0 V up to 3.2 V), very low noise and high PSRR for noise sensitive applications. Due to its low quiescent current, the T30LMPSR165 is suitable for battery powered devices such as smartphones and tablets. The device is designed to work with a 1  $\mu$ F input and 1  $\mu$ F output ceramic capacitor. It is available in ultra-small 0.35P, 0.64 mm x 0.64 mm Chip Scale Package (CSP).

### Features

- Market Leading Load Transient Response: 0 to 300 mA in 100 ns
  - ◆ Voltage Undershoot: 30 mV
  - ◆ Settling Time: 0.8  $\mu$ s
- $\pm 1\%$  Accuracy Over Load/Temperature
- Very Low Dropout: 26 mV for 2.85 V @ 300 mA
- High PSRR: Typ. 50 dB at 20 mA, f = 100 kHz
- Operating Input Voltage Range: 1.4 V to 3.6 V
- Available in Fixed Voltage Option: 1.0 V to 3.2 V
- Ultra Low Noise: 16  $\mu$ V<sub>RMS</sub>
- Stable with a 1  $\mu$ F eff. Output Capacitance
- Available in WLCSP4 0.64 mm x 0.64 mm x 0.33 mm Package
- These Devices are Pb-Free, Halogen Free and are RoHS Compliant

### Typical Applications

- Battery-powered Equipment
- Wireless LAN Devices
- Smartphone, Tablets
- Cameras, DVRs, STB and Camcorders



WLCSP4  
CASE 567VS

X = Specific Device Code  
M = Date Code

### MARKING DIAGRAM



### PIN CONNECTIONS

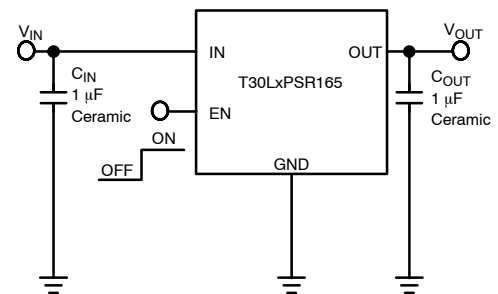
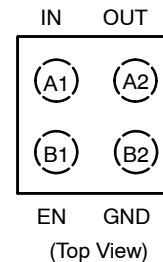

Figure 1. Typical Application Schematic

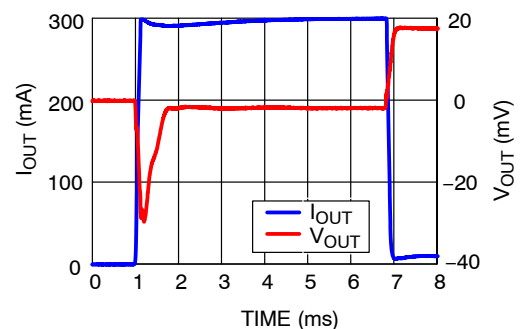

Figure 2. Load Transient Response for C<sub>OUT</sub> 1  $\mu$ F and Load Step 100  $\mu$ A to 300 mA with Rise Time 0.1  $\mu$ s

### ORDERING INFORMATION

See detailed ordering, marking and shipping information on page 13 of this data sheet.

## T30LMPSR165

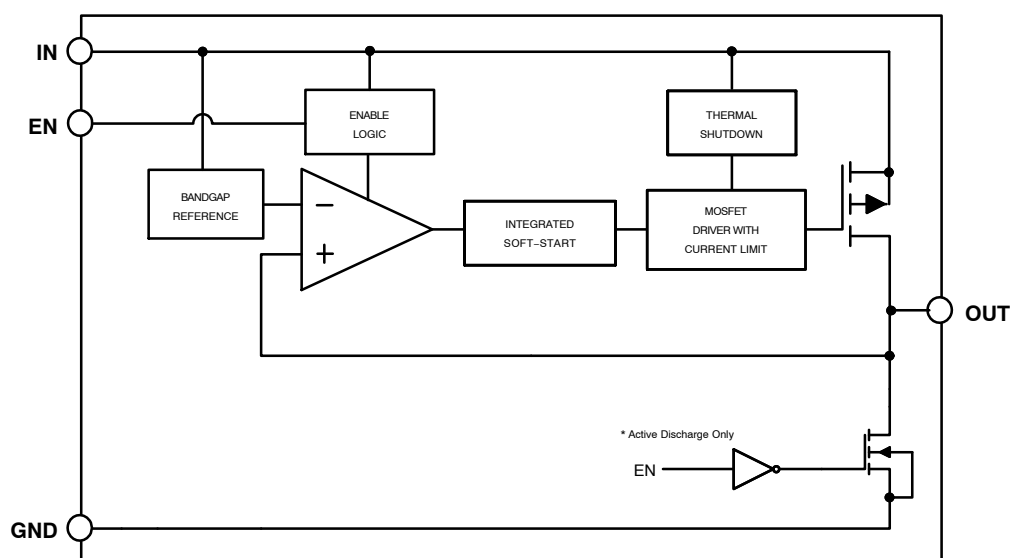

Figure 3. Simplified Schematic Block Diagram

### PIN FUNCTION DESCRIPTION

Pin No. WLCSP4	Pin Name	Description
A1	IN	Input voltage supply pin
A2	OUT	Regulated output voltage. The output should be bypassed with small 1 $\mu$ F ceramic capacitor.
B1	EN	Chip enable: Applying $V_{EN} < 0.3$ V disables the regulator, Pulling $V_{EN} > 0.825$ V enables the LDO.
B2	GND	Common ground connection

### ABSOLUTE MAXIMUM RATINGS

Rating	Symbol	Value	Unit
Input Voltage (Note 1)	$V_{IN}$	-0.3 to 4	V
Output Voltage	$V_{OUT}$	-0.3 to $(V_{IN} + 0.3) \leq 4$ , whichever is lower	V
Enable Voltage	$V_{EN}$	-0.3 to 4	V
Maximum Junction Temperature	$T_{J(max)}$	150	$^{\circ}$ C
Storage Temperature Range	$T_{STG}$	-65 to 150	$^{\circ}$ C
ESD Capability, Human Body Model (Note 2)	ESD <sub>HBM</sub>	2	kV
ESD Capability, Charged Device Model (Note 2)	ESD <sub>CDM</sub>	1	kV

Stresses exceeding those listed in the Maximum Ratings table may damage the device. If any of these limits are exceeded, device functionality should not be assumed, damage may occur and reliability may be affected.

1. Refer to ELECTRICAL CHARACTERISTICS, RECOMMENDED OPERATING RANGES and APPLICATION INFORMATION for Safe Operating Area.
2. This device series incorporates ESD protection and is tested by the following methods:  
 ESD Human Body Model tested per AEC-Q100-002 (EIA/JESD22-A114)  
 ESD Machine Model tested per AEC-Q100-003 (EIA/JESD22-A115)  
 Latchup Current Maximum Rating:  $\leq 150$  mA per JEDEC standard: JESD78

### THERMAL CHARACTERISTICS

Rating	Symbol	Value	Unit
Thermal Characteristics, WLCSP4 (Note 3), Thermal Resistance, Junction-to-Air	$R_{\theta JA}$	101	$^{\circ}$ C/W

3. This junction-to-ambient thermal resistance under natural convection was derived by thermal simulations based on the JEDEC JESD51 series standards methodology. Only a single device mounted at the center of a high\_K (2s2p) 80 mm x 80 mm multilayer board with 1-ounce internal planes and 2-ounce copper on top and bottom. Top copper layer has a dedicated 1.6 mm<sup>2</sup> copper area.

# T30LMPSR165

## RECOMMENDED OPERATING CONDITIONS

Parameter	Symbol	Min	Max	Unit
Input Voltage (Note 4)	$V_{IN}$	1.4	3.6	V
Enable Voltage	$V_{EN}$	0	3.6	V
Input Capacitance (Note 5)	$C_{IN}$	1		$\mu\text{F}$
Output Capacitance (Note 5)	$C_{OUT}$	1	47	$\mu\text{F}$
Junction Temperature	$T_J$	-40	125	$^{\circ}\text{C}$

Functional operation above the stresses listed in the Recommended Operating Ranges is not implied. Extended exposure to stresses beyond the Recommended Operating Ranges limits may affect device reliability.

4. Minimum  $V_{IN} = 1.4\text{ V}$  or  $(V_{OUT} + V_{DO})$ , whichever is higher.

5. The specified value refers to the effective capacitance, accounting for all relevant derating factors, including DC bias, temperature, and capacitor tolerance.

## ELECTRICAL CHARACTERISTICS

( $-40\text{ }^{\circ}\text{C} \leq T_J \leq 125\text{ }^{\circ}\text{C}$ ;  $V_{IN} = V_{OUT(NOM)} + 0.1\text{ V}$  or **1.4 V**, whichever is greater;  $I_{OUT} = 1\text{ mA}$ ;  $C_{IN} = C_{OUT} = 1\text{ }\mu\text{F}$  eff., unless otherwise noted.  $V_{EN} = 1\text{ V}$ . Typical values are at  $T_J = +25\text{ }^{\circ}\text{C}$  (Note 6))

Parameter	Test Conditions	Symbol	Min	Typ	Max	Unit	
Operating Input Voltage		$V_{IN}$	1.4		3.6	V	
Output Voltage Accuracy	$I_{OUT} = 1\text{ mA to }300\text{ mA}$	$V_{OUT(NOM)} \leq 1.4\text{ V}$	$V_{OUT}$		+15	mV	
					-1	+1	%
Line Regulation	$V_{OUT(NOM)} + 0.5\text{ V} \leq V_{IN} \leq 3.6\text{ V}$ , ( $V_{IN} \geq 1.4\text{ V}$ )	LineReg		0.02		%/V	
Load Regulation	$I_{OUT} = 1\text{ mA to }300\text{ mA}$	LoadReg		0.001		%/mA	
Dropout Voltage (Note 7)	$V_{OUT(NOM)} = 2.85\text{ V}$ $I_{OUT} = 300\text{ mA}$	$V_{DO}$		26	70	mV	
Current Limit	$V_{OUT} = 90\% \times V_{OUT(NOM)}$	$I_{CL}$	325	570		mA	
Quiescent Current	$I_{OUT} = 0\text{ mA}$	$I_Q$		240	300	$\mu\text{A}$	
Shutdown Current	$V_{EN} \leq 0.285\text{ V}$	$T_J \leq 85\text{ }^{\circ}\text{C}$	$I_{SHUT}$		0.01	1	$\mu\text{A}$
						3.5	
EN Pin Threshold Voltage	EN Input Voltage "H"	$V_{ENH}$	0.77			V	
	EN Input Voltage "L"	$T_J \leq 85\text{ }^{\circ}\text{C}$			0.325		
					0.285		
EN Pull Down Current	$V_{EN} = 3.6\text{ V}$	$I_{EN}$		0.1	0.5	$\mu\text{A}$	
Power Supply Rejection Ratio	$I_{OUT} = 20\text{ mA}$	PSRR		f = 100 Hz	70	dB	
				f = 1 kHz	70		
				f = 10 kHz	65		
				f = 100 kHz	50		
Output Voltage Noise	f = 10 Hz to 100 kHz	$V_N$		16		$\mu\text{V}_{RMS}$	
Thermal Shutdown Threshold	Temperature rising	$T_{SDH}$		160		$^{\circ}\text{C}$	
	Temperature falling	$T_{SDL}$		140		$^{\circ}\text{C}$	
Active Output Discharge Resistance	$V_{EN} < 0.285\text{ V}$	$R_{DIS}$		280		$\Omega$	

Product parametric performance is indicated in the Electrical Characteristics for the listed test conditions, unless otherwise noted. Product performance may not be indicated by the Electrical Characteristics if operated under different conditions.

## T30LMPSR165

### T30LxPSR165CFCT120T2G CHARACTERISTICS

$-40\text{ }^{\circ}\text{C} \leq T_J \leq 125\text{ }^{\circ}\text{C}$ ;  $V_{IN} = 1.4\text{ V}$ ,  $V_{OUT(NOM)} = 1.2\text{ V}$ , whichever is greater;  $I_{OUT} = 1\text{ mA}$ ;  $C_{IN} = C_{OUT} = 1\text{ }\mu\text{F}$  eff., unless otherwise noted.  $V_{EN} = 1\text{ V}$ . Typical values are at  $T_J = +25\text{ }^{\circ}\text{C}$  (Note 6)

Parameter	Test Conditions	Symbol	Min	Typ	Max	Unit
Delay Time	From assertion of $V_{EN}$ to output voltage increase	$t_{DELAY}$		120		$\mu\text{s}$
Rise Time	$V_{OUT}$ rise from 5% to 95% $V_{OUT(NOM)}$	$t_{RISE}$		340		
Turn-on Time	From assertion of $V_{EN}$ to $V_{OUT} = 95\%$ $V_{OUT(NOM)}$	$t_{ON}$		500		

### T30LxPSR165CFCT200T2G CHARACTERISTICS

$-40\text{ }^{\circ}\text{C} \leq T_J \leq 125\text{ }^{\circ}\text{C}$ ;  $V_{IN} = 2.1\text{ V}$ ,  $V_{OUT(NOM)} = 2.0\text{ V}$ , whichever is greater;  $I_{OUT} = 1\text{ mA}$ ;  $C_{IN} = C_{OUT} = 1\text{ }\mu\text{F}$  eff., unless otherwise noted.  $V_{EN} = 1\text{ V}$ . Typical values are at  $T_J = +25\text{ }^{\circ}\text{C}$  (Note 6)

Parameter	Test Conditions	Symbol	Min	Typ	Max	Unit
Delay Time	From assertion of $V_{EN}$ to output voltage increase	$t_{DELAY}$		120		$\mu\text{s}$
Rise Time	$V_{OUT}$ rise from 5% to 95% $V_{OUT(NOM)}$	$t_{RISE}$		610		
Turn-on Time	From assertion of $V_{EN}$ to $V_{OUT} = 95\%$ $V_{OUT(NOM)}$	$t_{ON}$		790		

### T30LxPSR165CFCT285T2G CHARACTERISTICS

$-40\text{ }^{\circ}\text{C} \leq T_J \leq 125\text{ }^{\circ}\text{C}$ ;  $V_{IN} = 2.95\text{ V}$ ,  $V_{OUT(NOM)} = 2.85\text{ V}$ , whichever is greater;  $I_{OUT} = 1\text{ mA}$ ;  $C_{IN} = C_{OUT} = 1\text{ }\mu\text{F}$  eff., unless otherwise noted.  $V_{EN} = 1\text{ V}$ . Typical values are at  $T_J = +25\text{ }^{\circ}\text{C}$  (Note 6)

Parameter	Test Conditions	Symbol	Min	Typ	Max	Unit
Delay Time	From assertion of $V_{EN}$ to output voltage increase	$t_{DELAY}$		120		$\mu\text{s}$
Rise Time	$V_{OUT}$ rise from 5% to 95% $V_{OUT(NOM)}$	$t_{RISE}$		820		
Turn-on Time	From assertion of $V_{EN}$ to $V_{OUT} = 95\%$ $V_{OUT(NOM)}$	$t_{ON}$		1000		

Product parametric performance is indicated in the Electrical Characteristics for the listed test conditions, unless otherwise noted. Product performance may not be indicated by the Electrical Characteristics if operated under different conditions.

- Performance guaranteed over the indicated operating temperature range by design and/or characterization. Production tested at  $T_A = 25\text{ }^{\circ}\text{C}$ . Low duty cycle pulse techniques are used during the testing to maintain the junction temperature as close to ambient as possible.
- Dropout voltage is characterized when  $V_{OUT}$  falls about 3% below  $V_{OUT(NOM)}$ .

# T30LMPSR165

## TYPICAL CHARACTERISTICS

$T_J = 25\text{ }^\circ\text{C}$ ;  $V_{IN} = V_{OUT(NOM)} + 0.1\text{ V}$ , whichever is greater,  $I_{OUT} = 1\text{ mA}$ ,  $C_{IN} = C_{OUT} = 1\text{ }\mu\text{F}$  eff., unless otherwise noted.  $V_{EN} = 1.0\text{ V}$

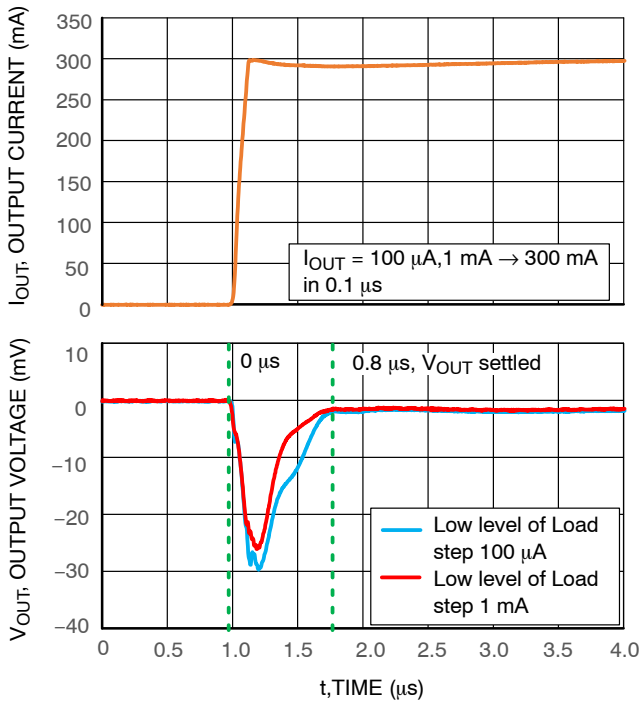

**Figure 4. Load Transient Response for 0.1  $\mu\text{s}$  Edge and Different Low Level of Load Step**

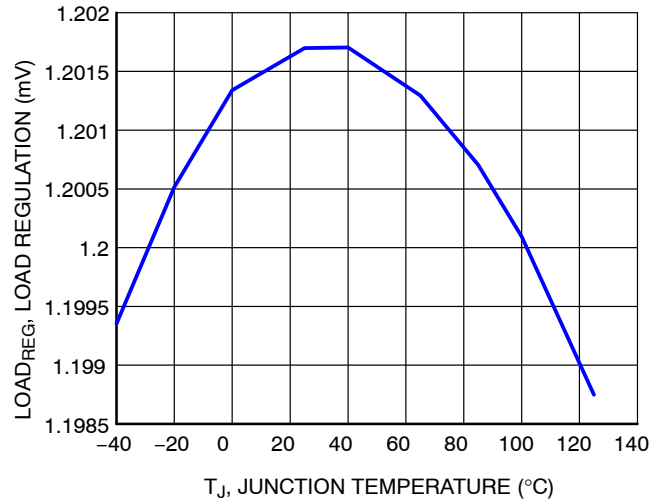

**Figure 5. Output Voltage vs. Temperature -  $V_{OUT(NOM)} = 1.2\text{ V}$**

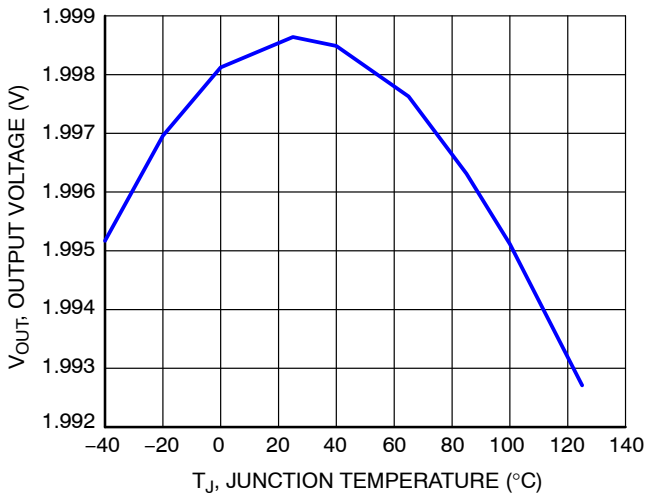

**Figure 6. Output Voltage vs. Temperature -  $V_{OUT(NOM)} = 2.0\text{ V}$**

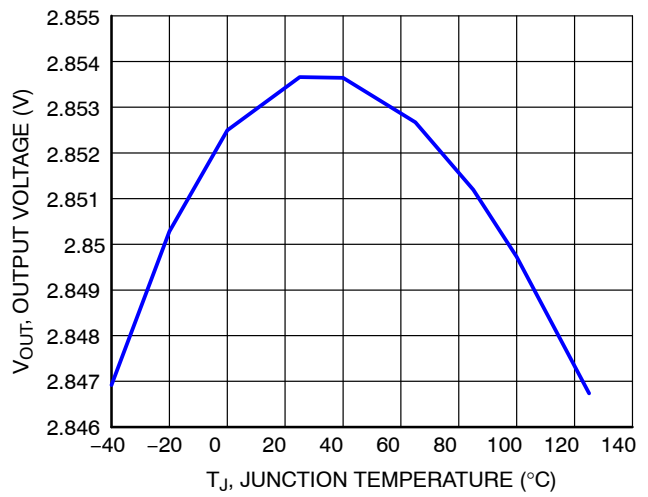

**Figure 7. Output Voltage vs. Temperature -  $V_{OUT(NOM)} = 2.85\text{ V}$**

# T30LMPSR165

## TYPICAL CHARACTERISTICS

$T_J = 25\text{ }^\circ\text{C}$ ;  $V_{IN} = V_{OUT(NOM)} + 0.1\text{ V}$ , whichever is greater,  $I_{OUT} = 1\text{ mA}$ ,  $C_{IN} = C_{OUT} = 1\text{ }\mu\text{F}$  eff., unless otherwise noted.  $V_{EN} = 1.0\text{ V}$

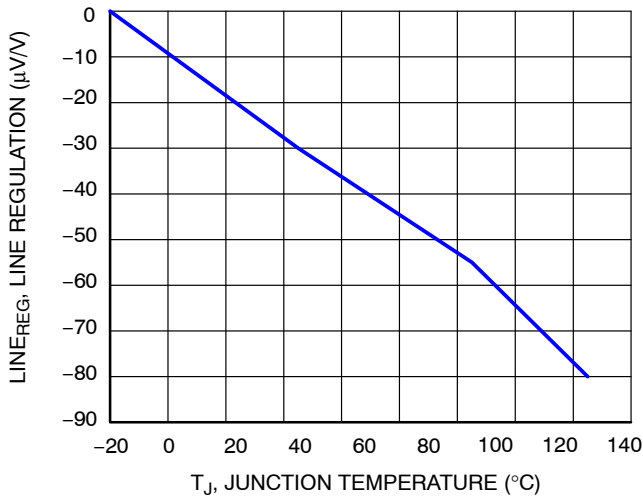

Figure 8. Line Regulation vs. Temperature

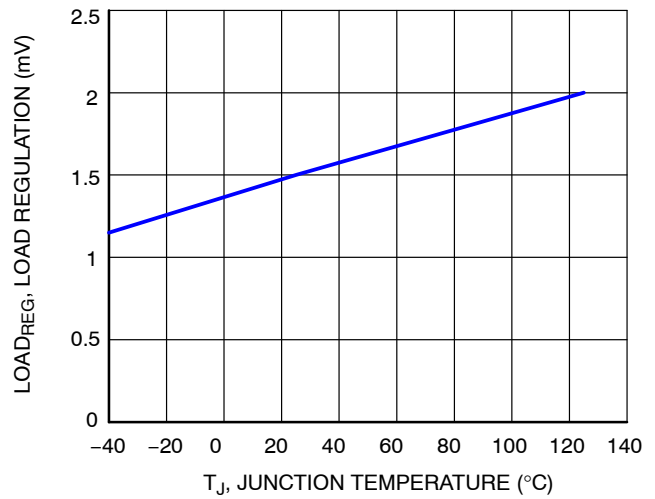

Figure 9. Load Regulation vs. Temperature

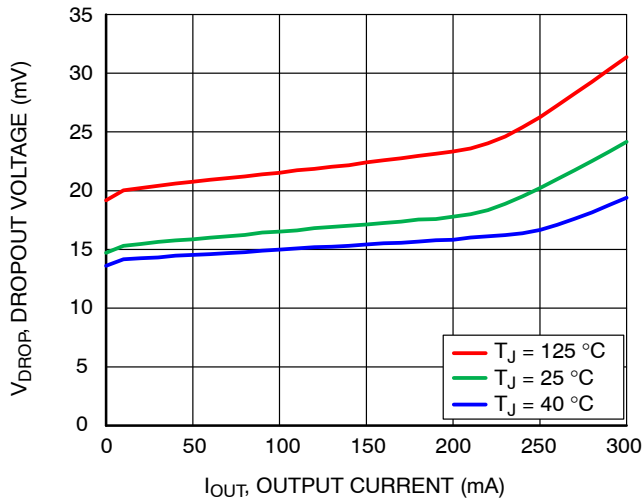

Figure 10. Dropout Voltage vs. Output Current –  $V_{OUT(NOM)} = 2.0\text{ V}$

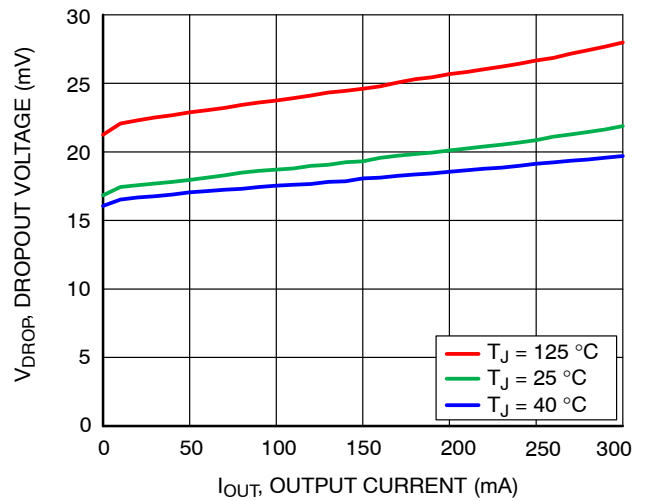

Figure 11. Dropout Voltage vs. Output Current –  $V_{OUT(NOM)} = 2.85\text{ V}$

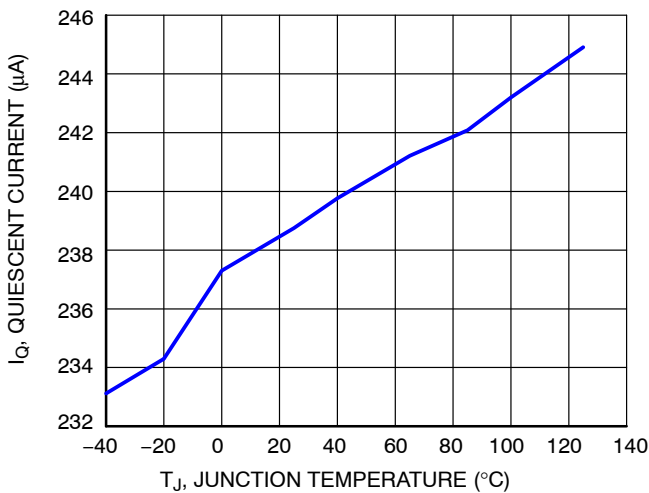

Figure 12. Quiescent Current vs. Temperature

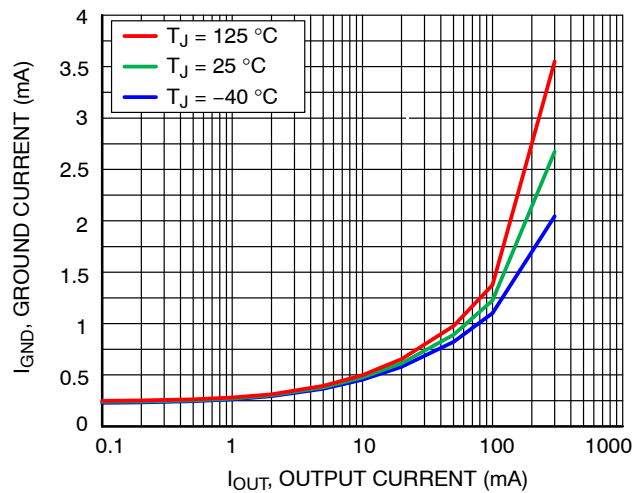
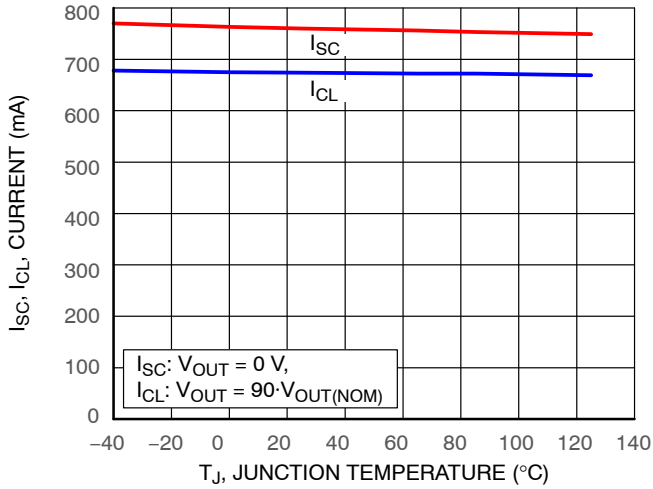

Figure 13. Current Limit and Short-Circuit Current vs. Temperature

# T30LMPSR165

## TYPICAL CHARACTERISTICS

$T_J = 25\text{ }^\circ\text{C}$ ;  $V_{IN} = V_{OUT(NOM)} + 0.1\text{ V}$ , whichever is greater,  $I_{OUT} = 1\text{ mA}$ ,  $C_{IN} = C_{OUT} = 1\text{ }\mu\text{F}$  eff., unless otherwise noted.  $V_{EN} = 1.0\text{ V}$



**Figure 14. Limit Current and Short-Circuit Current vs. Temperature**

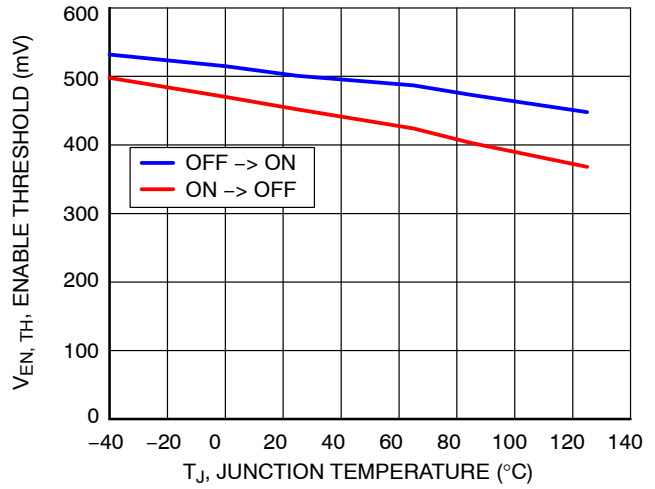

**Figure 15. Enable Threshold vs. Temperature**

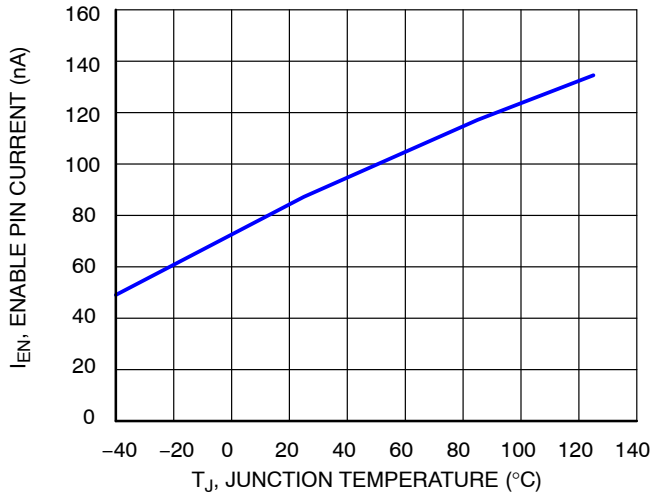

**Figure 16. Enable Pin current vs. Temperature**

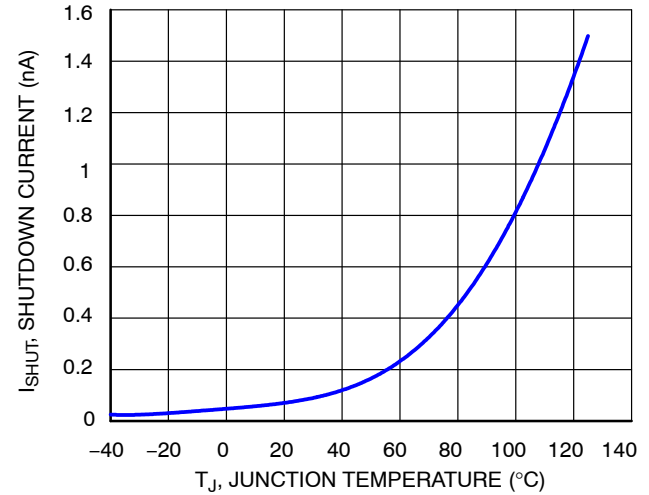

**Figure 17. Shutdown Current vs. Temperature**

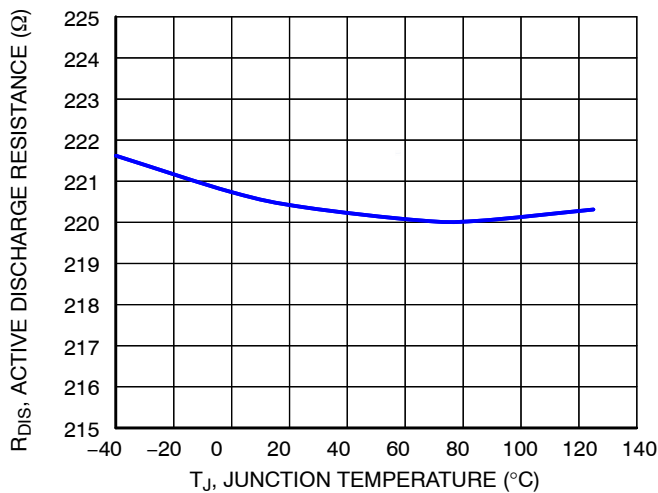
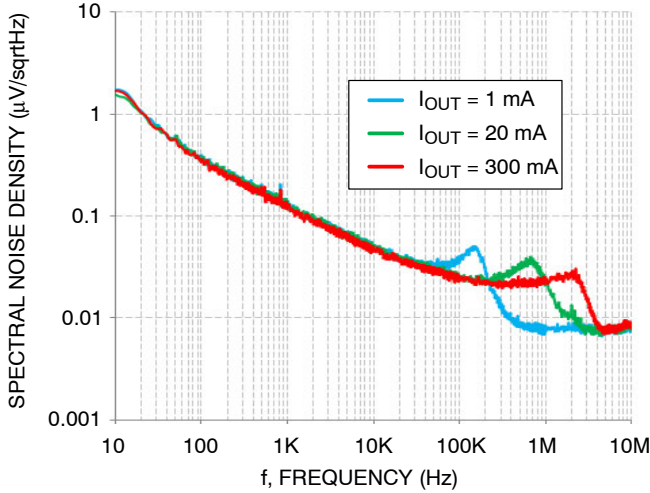

**Figure 18. Active Discharge Resistance vs. Temperature**

# T30LMPSR165

## TYPICAL CHARACTERISTICS

$T_J = 25\text{ }^\circ\text{C}$ ;  $V_{IN} = V_{OUT(NOM)} + 0.1\text{ V}$ , whichever is greater,  $I_{OUT} = 1\text{ mA}$ ,  $C_{IN} = C_{OUT} = 1\text{ }\mu\text{F}$  eff., unless otherwise noted.  $V_{EN} = 1.0\text{ V}$



**Figure 19. Spectral Noise Density vs. Frequency for Different  $I_{OUT}$**

$I_{OUT}$ (mA)	Output Noise ( $\mu\text{V}_{RMS}$ )	
	10 Hz – 100 kHz	100 Hz – 100 kHz
1	15.6	14.0
20	14.5	13.0
300	14.1	12.6

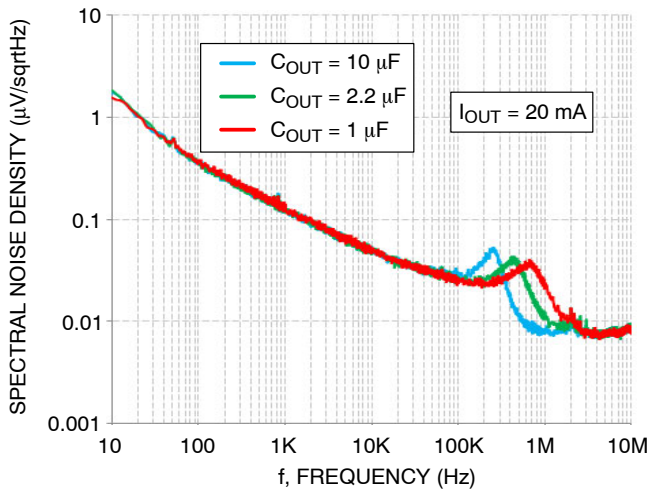

**Figure 20. Spectral Noise Density vs. Frequency for Different  $C_{OUT}$**

$C_{OUT}$ ( $\mu\text{F}$ )	RMS Output Noise ( $\mu\text{V}$ )	
	10 Hz – 100 kHz	100 Hz – 100 kHz
1	14.5	13.0
2.2	14.5	13.0
10	14.6	13.0

# T30LMPSR165

## TYPICAL CHARACTERISTICS

$T_J = 25\text{ }^\circ\text{C}$ ;  $V_{IN} = V_{OUT(NOM)} + 0.1\text{ V}$ , whichever is greater,  $I_{OUT} = 1\text{ mA}$ ,  $C_{IN} = C_{OUT} = 1\text{ }\mu\text{F}$  eff., unless otherwise noted.  $V_{EN} = 1.0\text{ V}$

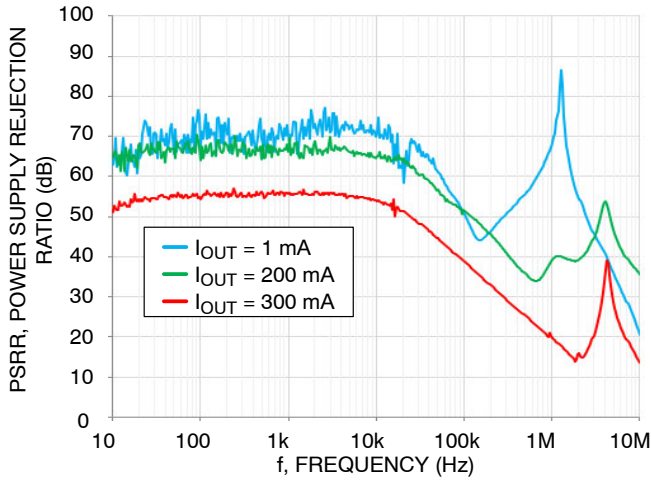

Figure 21. PSRR vs. Frequency for Different  $I_{OUT}$

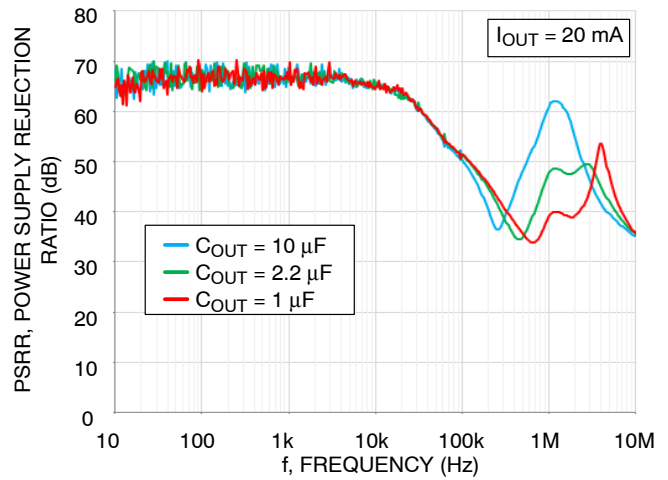

Figure 22. PSRR vs. Frequency for Different  $C_{OUT}$

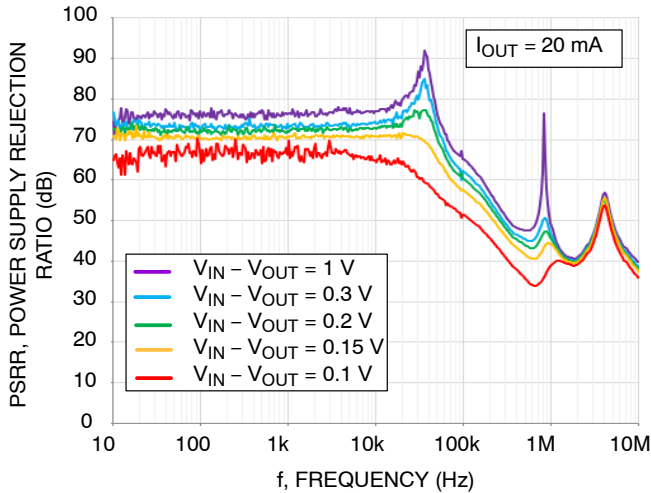

Figure 23. PSRR vs. Frequency -  $V_{OUT(NOM)} = 2.85\text{ V}$

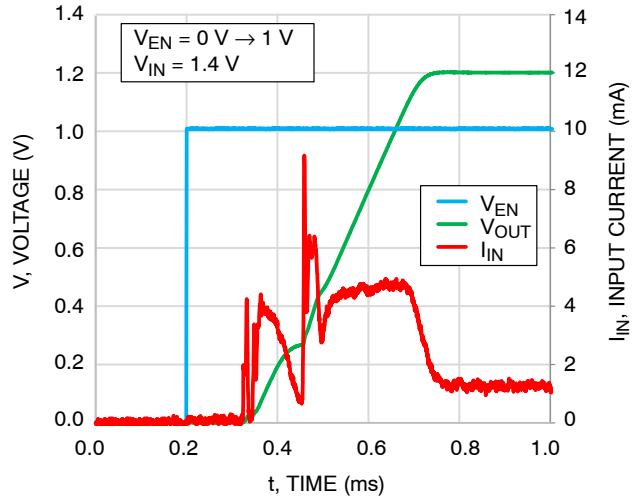

Figure 24. Enable Transient Response -  $V_{OUT(NOM)} = 1.2\text{ V}$

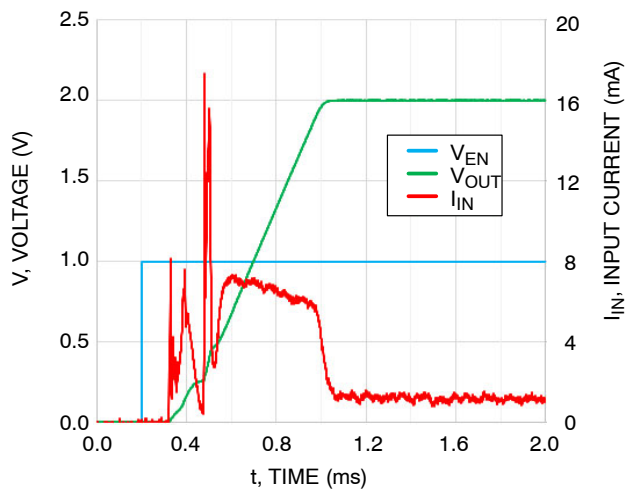

Figure 25. Enable Transient Response -  $V_{OUT(NOM)} = 2.0\text{ V}$

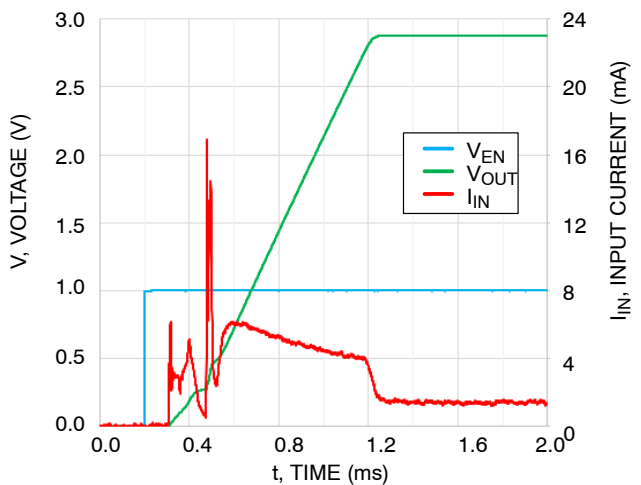

Figure 26. Enable Transient Response -  $V_{OUT(NOM)} = 2.85\text{ V}$

# T30LMPSR165

## TYPICAL CHARACTERISTICS

$T_J = 25^\circ\text{C}$ ;  $V_{IN} = V_{OUT(NOM)} + 0.1\text{ V}$ , whichever is greater,  $I_{OUT} = 1\text{ mA}$ ,  $C_{IN} = C_{OUT} = 1\ \mu\text{F}$  eff., unless otherwise noted.  $V_{EN} = 1.0\text{ V}$

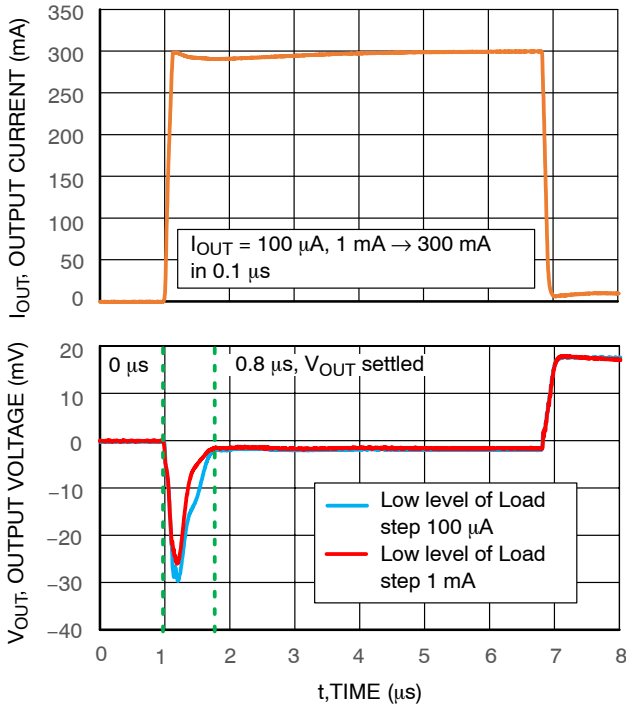

Figure 27. Load Transient Response for  $0.1\ \mu\text{s}$  Edge and Different Low Level of Load Step

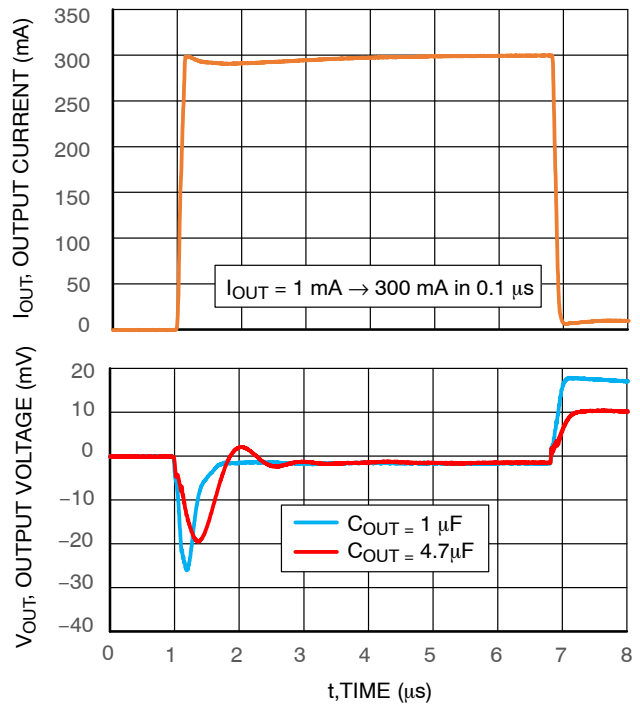

Figure 28. Load Transient Response for  $0.1\ \mu\text{s}$  Edge and Different  $C_{OUT}$

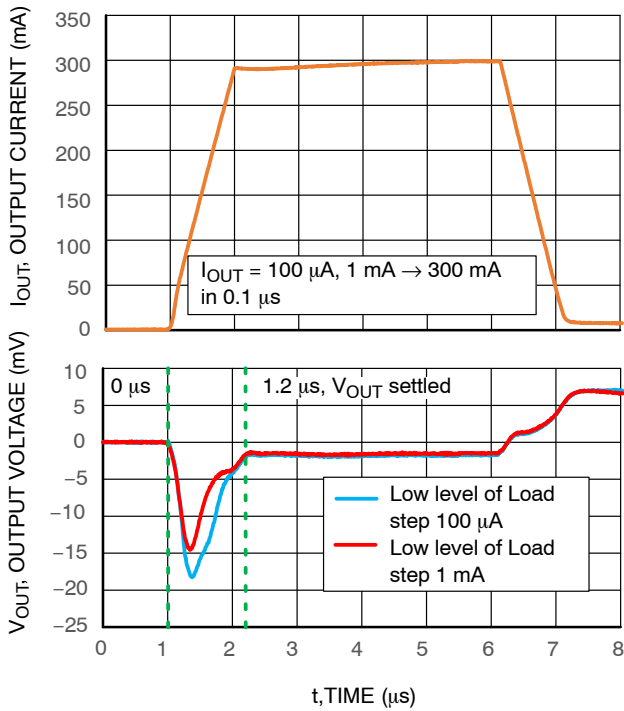

Figure 29. Load Transient Response for  $1\ \mu\text{s}$  Edge and Different Low Level of Load Step

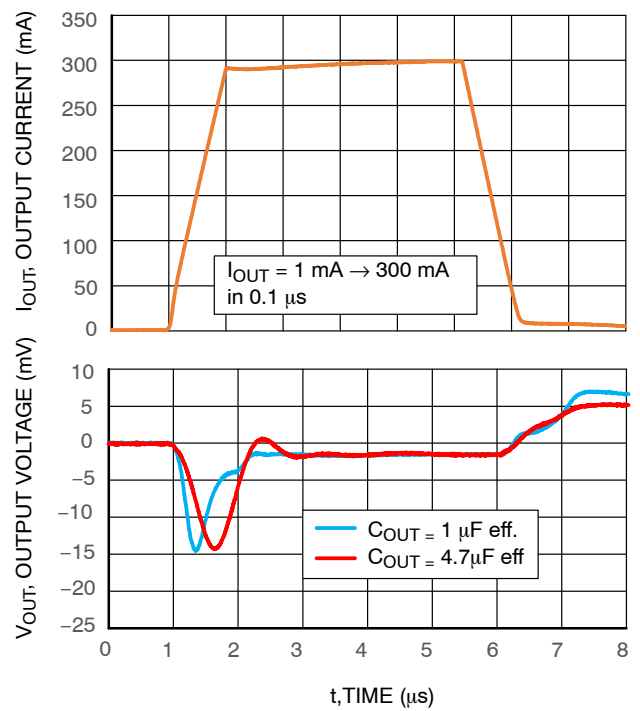
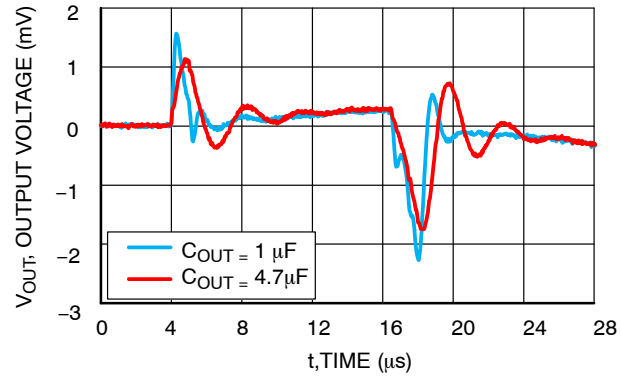
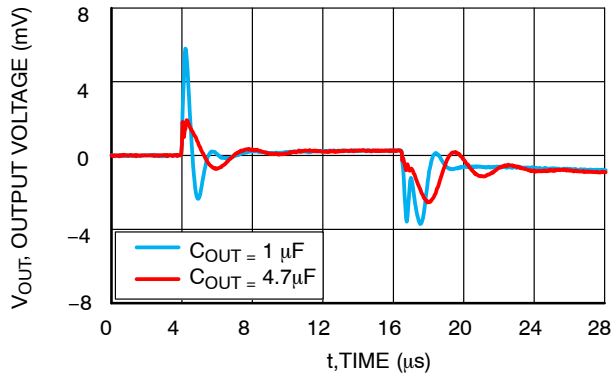
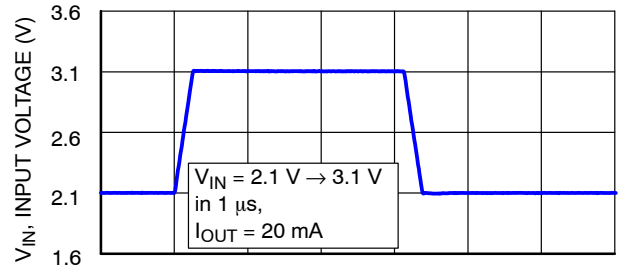
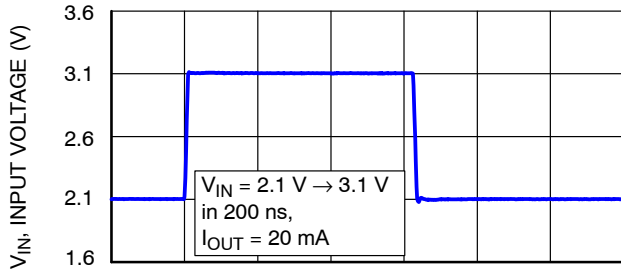

Figure 30. Line Transient Response for  $1\ \mu\text{s}$  Edge and Different  $C_{OUT}$

# T30LMPSR165

## TYPICAL CHARACTERISTICS

$T_J = 25\text{ }^\circ\text{C}$ ;  $V_{IN} = V_{OUT(NOM)} + 0.1\text{ V}$ , whichever is greater,  $I_{OUT} = 1\text{ mA}$ ,  $C_{IN} = C_{OUT} = 1\text{ }\mu\text{F}$  eff., unless otherwise noted.  $V_{EN} = 1.0\text{ V}$



**Figure 31. Line Transient Response for 0.2  $\mu\text{s}$  Edge and Different  $C_{OUT}$**

**Figure 32. Line Transient Response for 1  $\mu\text{s}$  Edge and Different  $C_{OUT}$**

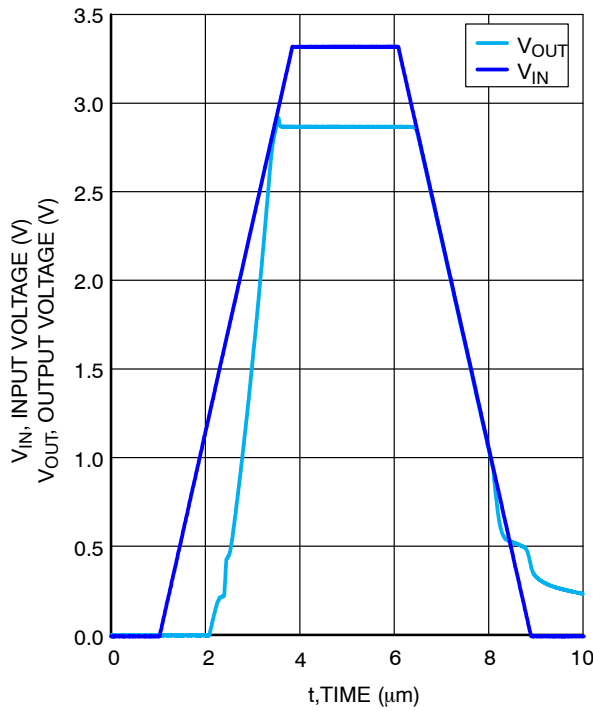

**Figure 33. Turn On/Off – Slow Rising –  $V_{OUT(NOM)} = 2.85\text{ V}$**

## APPLICATIONS INFORMATION

**General**

The T30LMPSR165 is an ultra-fast transient 300 mA low dropout regulator designed to meet the requirements of low voltage RF applications and high performance analog circuits. The T30LMPSR165 device provides excellent dynamic response, very high PSRR and low noise. In connection with low quiescent current this device is well suitable for battery powered application such as cell phones, tablets and other. The T30LMPSR165 is fully protected in case of current overload, output short circuit and overheating.

**Input Capacitor Selection ( $C_{IN}$ )**

Input capacitor connected as close as possible is necessary for ensure device stability. The X7R or X5R capacitor should be used for reliable performance over temperature range. The value of the input capacitor should be 0.75  $\mu$ F or greater to ensure the best dynamic performance. This capacitor will provide a low impedance path for unwanted AC signals or noise modulated onto constant input voltage. There is no requirement for the ESR of the input capacitor but it is recommended to use ceramic capacitors for their low ESR and ESL. A good input capacitor will limit the influence of input trace inductance and source resistance during sudden load current changes.

**Output Capacitor Selection ( $C_{OUT}$ )**

The T30LMPSR165 requires an output capacitor connected as close as possible to the output pin of the regulator. The recommended capacitor value is 1  $\mu$ F and X7R or X5R dielectric due to its low capacitance variations over the specified temperature range. The T30LMPSR165 is designed to remain stable with minimum effective capacitance of 0.6  $\mu$ F to account for changes with temperature, DC bias and package size. Especially for small package size capacitors such as 0201 the effective capacitance drops rapidly with the applied DC bias. Please refer to Figure 34.

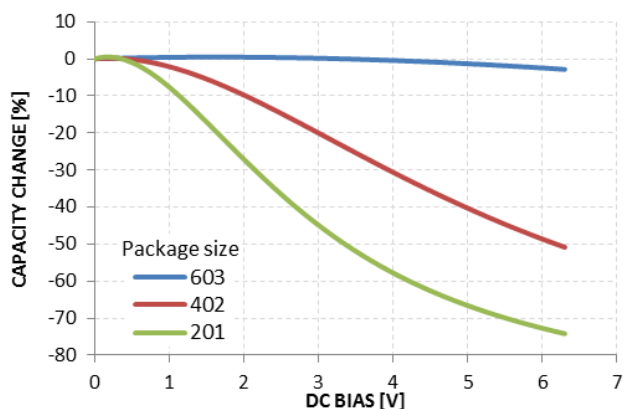

Figure 34. Capacity vs DC Bias Voltage

There is no requirement for the minimum value of Equivalent Series Resistance (ESR) for the  $C_{OUT}$ . Larger output capacitors and lower ESR could improve the load transient response or high frequency PSRR. It is not recommended to use tantalum capacitors on the output due to their large ESR. The equivalent series resistance of tantalum capacitors is also strongly dependent on the temperature, increasing at low temperature.

**Enable Operation**

The T30LMPSR165 uses the EN pin to enable/disable its device and to deactivate/activate the active discharge function. If the EN pin voltage is  $< 0.325$  V the device is guaranteed to be disabled. The pass transistor is turned-off so that there is virtually no current flow between the IN and OUT. The active discharge transistor is active so that the output voltage  $V_{OUT}$  is pulled to GND through a 280  $\Omega$  resistor. In the disable state the device consumes as low as typ. 0.01  $\mu$ A from the  $V_{IN}$ . If the EN pin voltage is  $> 0.825$  V the device is guaranteed to be enabled. The T30LMPSR165 regulates the output voltage and the active discharge transistor is turned-off. The EN pin has internal pull-down current source with typ. value of 0.1  $\mu$ A which assures that the device is turned-off when the EN pin is not connected. In the case where the EN function isn't required the EN should be tied directly to IN.

**Output Current Limit**

Output Current is internally limited within the IC to a typical 570 mA. The T30LMPSR165 will source this amount of current measured with a voltage drops on the 90% of the nominal  $V_{OUT}$ . The current limit and short circuit protection will work properly over whole temperature range and also input voltage range. There is no limitation for the short circuit duration.

**Thermal Shutdown**

When the die temperature exceeds the Thermal Shutdown threshold (TSD – 160  $^{\circ}$ C typical), Thermal Shutdown event is detected and the device is disabled. The IC will remain in this state until the die temperature decreases below the Thermal Shutdown Reset threshold ( $T_{SDL}$  – 140  $^{\circ}$ C typical). Once the IC temperature falls below the 140  $^{\circ}$ C the LDO is enabled again. The thermal shutdown feature provides the protection from a catastrophic device failure due to accidental overheating. This protection is not intended to be used as a substitute for proper heat sinking.

**Power Dissipation**

As power dissipated in the T30LMPSR165 increases, it might become necessary to provide some thermal relief. The maximum power dissipation supported by the device is dependent upon board design and layout. Mounting pad configuration on the PCB, the board material, and the ambient temperature affect the rate of junction temperature

## T30LMPSR165

rise for the part. The maximum power dissipation the T30LMPSR165 can handle is given by:

$$P_{D(MAX)} = \frac{125\text{ }^{\circ}\text{C} - T_A}{\theta_{JA}} \quad (\text{eq. 1})$$

The power dissipated by the T30LMPSR165 for given application conditions can be calculated from the following equations:

$$P_D \approx V_{IN} \cdot I_{GND} + I_{OUT}(V_{IN} - V_{OUT}) \quad (\text{eq. 2})$$

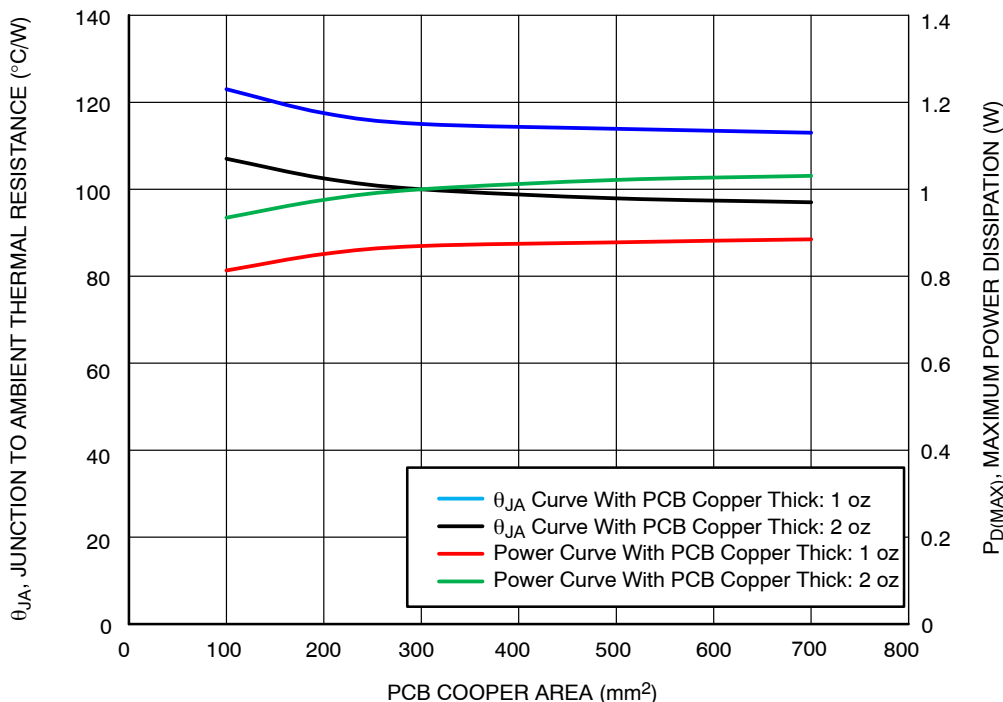

Figure 35.  $\theta_{JA}$  and  $P_{D(MAX)}$  vs. PCB Copper Area (CSP4)

### ORDERING INFORMATION

Device	Nominal Output Voltage	Marking	Rotation	Description	Package	Shipping <sup>†</sup>
T30LMPSR165CFCT100T2G (Consult <b>onsemi</b> sales)	1.00 V	3	90°	300 mA LDO, with Active Discharge Feature	WLCSP4 CASE 567VS (Pb-Free) UBM: 200 $\mu$ m Bump type: Sn Plate	10000 / Tape & Reel
T30LMPSR165CFCT105T2G (Consult <b>onsemi</b> sales)	1.05 V	4	90°			
T30LMPSR165CFCT110T2G	1.10 V	K	0°			
T30LMPSR165CFCT120T2G	1.20 V	U	0°			
T30LMPSR165CFCT125T2G (Consult <b>onsemi</b> sales)	1.25 V	5	90°			
T30LMPSR165CFCT180T2G	1.80 V	3	0°			
T30LMPSR165CFCT200T2G	2.00 V	L	0°			
T30LMPSR165CFCT280T2G	2.80 V	V	0°			
T30LMPSR165CFCT285T2G	2.85 V	Y	0°			

<sup>†</sup> For information on tape and reel specifications, including part orientation and tape sizes, please refer to our Tape and Reel Packaging Specifications Brochure, [BRD8011/D](#).

# T30LMPSR165

## REVISION HISTORY

Revision	Description of Changes	Date
P7	Updated Figure 2 on page 1. Added Typical Characteristics section (Figures 4–33). Added Applications Information section (adapted from SCY99579 datasheet, device name updated). Updated temperature limit in Equation (1) from 85 °C to 125 °C.	4/9/2026
0	Initial document release.	4/10/2026
1	Operating Input Voltage Range update, Absolute Maximum Ratings table update, Ordering Information table update, Note 3 of Thermal Characteristics table update, Recommended Operating Conditions table added.	4/21/2026

This document has undergone updates prior to the inclusion of this revision history table. The changes tracked here only reflect updates made on the noted approval dates.

SCALE 4:1

WLCSP4, 0.64x0.64x0.33  
CASE 567VS  
ISSUE O

DATE 25 JAN 2018

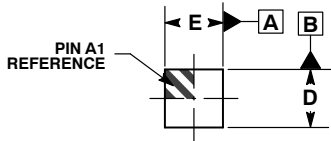

TOP VIEW

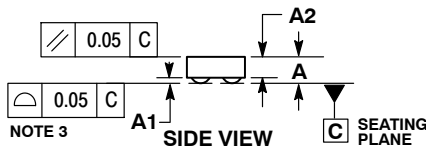

SIDE VIEW

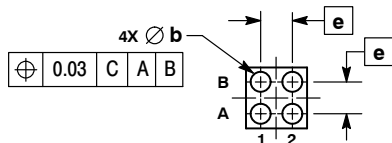

BOTTOM VIEW

RECOMMENDED  
SOLDERING FOOTPRINT\*

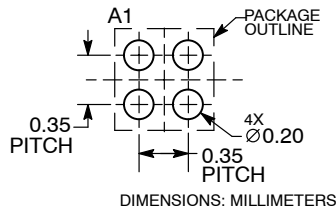

\*For additional information on our Pb-Free strategy and soldering details, please download the onsemi Soldering and Mounting Techniques Reference Manual, SOLDERRM/D.

NOTES:

1. DIMENSIONING AND TOLERANCING PER ASME Y14.5M, 1994.
2. CONTROLLING DIMENSION: MILLIMETERS.
3. COPLANARITY APPLIES TO SPHERICAL CROWNS OF SOLDER BALLS.

DIM	MILLIMETERS		
	MIN	NOM	MAX
A	---	---	0.33
A1	0.04	0.06	0.08
A2	0.23 REF		
b	0.180	0.200	0.220
D	0.610	0.640	0.670
E	0.610	0.640	0.670
e	0.35 BSC		

GENERIC  
MARKING DIAGRAM\*



X = Specific Device Code  
M = Month

\*This information is generic. Please refer to device data sheet for actual part marking. Pb-Free indicator, "G" or microdot "▪", may or may not be present. Some products may not follow the Generic Marking.

DOCUMENT NUMBER:	98AON82946G	Electronic versions are uncontrolled except when accessed directly from the Document Repository. Printed versions are uncontrolled except when stamped "CONTROLLED COPY" in red.
DESCRIPTION:	WLCSP4, 0.64X0.64X0.33	PAGE 1 OF 1

onsemi and ONSEMI are trademarks of Semiconductor Components Industries, LLC dba onsemi or its subsidiaries in the United States and/or other countries. onsemi reserves the right to make changes without further notice to any products herein. onsemi makes no warranty, representation or guarantee regarding the suitability of its products for any particular purpose, nor does onsemi assume any liability arising out of the application or use of any product or circuit, and specifically disclaims any and all liability, including without limitation special, consequential or incidental damages. onsemi does not convey any license under its patent rights nor the rights of others.

**onsemi**, **Onsemi**, and other names, marks, and brands are registered and/or common law trademarks of Semiconductor Components Industries, LLC dba "**onsemi**" or its affiliates and/or subsidiaries in the United States and/or other countries. **onsemi** owns the rights to a number of patents, trademarks, copyrights, trade secrets, and other intellectual property. A listing of **onsemi**'s product/patent coverage may be accessed at [www.onsemi.com/site/pdf/Patent-Marking.pdf](http://www.onsemi.com/site/pdf/Patent-Marking.pdf). **onsemi** reserves the right to make changes at any time to any products or information herein, without notice. The information herein is provided "as-is" and **onsemi** makes no warranty, representation or guarantee regarding the accuracy of the information, product features, availability, functionality, or suitability of its products for any particular purpose, nor does **onsemi** assume any liability arising out of the application or use of any product or circuit, and specifically disclaims any and all liability, including without limitation special, consequential or incidental damages. Buyer is responsible for its products and applications using **onsemi** products, including compliance with all laws, regulations and safety requirements or standards, regardless of any support or applications information provided by **onsemi**. "Typical" parameters which may be provided in **onsemi** data sheets and/or specifications can and do vary in different applications and actual performance may vary over time. All operating parameters, including "Typicals" must be validated for each customer application by customer's technical experts. **onsemi** does not convey any license under any of its intellectual property rights nor the rights of others. **onsemi** products are not designed, intended, or authorized for use as a critical component in life support systems or any FDA Class 3 medical devices or medical devices with a same or similar classification in a foreign jurisdiction or any devices intended for implantation in the human body. Should Buyer purchase or use **onsemi** products for any such unintended or unauthorized application, Buyer shall indemnify and hold **onsemi** and its officers, employees, subsidiaries, affiliates, and distributors harmless against all claims, costs, damages, and expenses, and reasonable attorney fees arising out of, directly or indirectly, any claim of personal injury or death associated with such unintended or unauthorized use, even if such claim alleges that **onsemi** was negligent regarding the design or manufacture of the part. **onsemi** is an Equal Opportunity/Affirmative Action Employer. This literature is subject to all applicable copyright laws and is not for resale in any manner.

## ADDITIONAL INFORMATION

### TECHNICAL PUBLICATIONS:

Technical Library: [www.onsemi.com/design/resources/technical-documentation](http://www.onsemi.com/design/resources/technical-documentation)  
onsemi Website: [www.onsemi.com](http://www.onsemi.com)

### ONLINE SUPPORT: [www.onsemi.com/support](http://www.onsemi.com/support)

For additional information, please contact your local Sales Representative at [www.onsemi.com/support/sales](http://www.onsemi.com/support/sales)

