

Flying Capacitor BOOST Module

NXH500B100H7F5SHG

The NXH500B100H7F5SHG is a power module in F5BP package containing two independent flying capacitor boost converters. The integrated field stop trench IGBTs and Si/SiC Diodes provide lower conduction and switching losses, enabling designers to achieve high efficiency, high power density and superior reliability.

Features

- Flying Capacitor Boost Module
- 1000V Field Stop 7 IGBTs and 1200 V SiC Diodes
- Low Inductive Layout
- Solder Pins
- Integrated NTC Thermistor
- This is a Pb-Free and Halide Free Device

Typical Applications

- Solar Inverter
- Energy Storage System

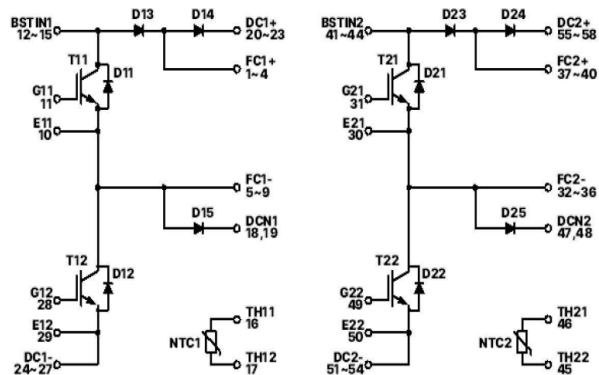
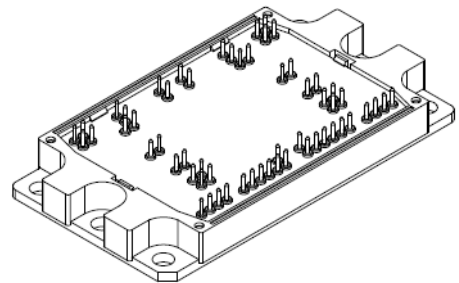
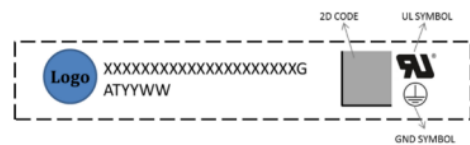

Figure 1. NXH500B100H7F5SHG Schematic Diagram



PIM58 112x62 (SOLDER PIN)
CASE 180CZ

MARKING DIAGRAM



XXXXXX = Device Code
G = Pb-Free Package
AT = Assembly & Test Site Code
YYWW = Year and Work Week Code

PIN CONNECTIONS

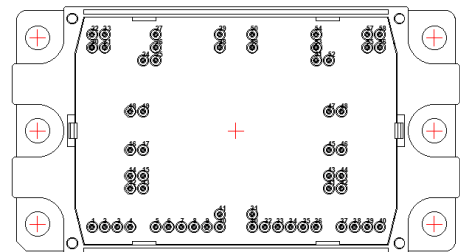

ORDERING INFORMATION

See detailed ordering and shipping information on page 5 of this data sheet.

NXH500B100H7F5SHG

MODULE CHARACTERISTICS

Rating	Symbol	Value	Unit
Operating Temperature under Switching Condition	TVJOP	-40 to 150	°C
Storage Temperature Range	T _{stg}	-40 to 125	°C
Isolation Test Voltage, t = 2 sec, 50 Hz (Note 1)	V _{is}	4800	V _{RMS}
Stray Inductance	L _s CE	15	nH
Terminal Connection Torque (M5, Screw)	M	3 to 5	Nm
Weight	G	245	g
Creepage Distance (terminal to heatsink)		17.46	mm
Creepage Distance (terminal to terminal)		6.48	mm
Clearance Distance (terminal to heatsink)		15.62	mm
Clearance Distance (terminal to terminal)		5.05	mm
Comparative Tracking Index	CTI	>600	

1. 4800 VAC_{RMS} for 2 second duration is equivalent to 2833 VAC_{RMS} for 1 minute duration.

ABSOLUTE MAXIMUM RATINGS T_J = 25 °C unless otherwise noted (Note 2)

Rating	Symbol	Value	Unit
--------	--------	-------	------

IGBT (T11, T12, T21, T22)

Collector-emitter voltage	V _{CES}	1000	V
Gate-Emitter Voltage	V _{GE}	±20	V
Positive transient gate-emitter voltage (T _{pulse} = 5 μs, D < 0.10)		30	
Continuous Collector Current @ T _C = 80 °C (T _J = 175 °C)	I _C	210	A
Pulsed Peak Collector Current @ T _C = 80 °C (T _J = 175 °C)	I _{C(Pulse)}	630	A
Power Dissipation (T _J = 175 °C, T _C = 80 °C)	P _{tot}	503	W
Minimum Operating Junction Temperature	T _{JMIN}	-40	°C
Maximum Operating Junction Temperature	T _{JMAX}	175	°C

IGBT INVERSE DIODE (D11, D12, D21, D22)

Peak Repetitive Reverse Voltage	V _{RRM}	1200	V
Continuous Forward Current @ T _C = 80 °C	I _F	125	A
Repetitive Peak Forward Current (T _J = 175 °C)	I _{FRM}	375	A
Maximum Power Dissipation @ T _C = 80 °C (T _J = 175 °C)	P _{tot}	203	W
Minimum Operating Junction Temperature	T _{JMIN}	-40	°C
Maximum Operating Junction Temperature	T _{JMAX}	175	°C

BOOST SILICON CARBIDE SCHOTTKY DIODE (D13, D14, D23, D24)

Peak Repetitive Reverse Voltage	V _{RRM}	1200	V
Continuous Forward Current @ T _C = 80 °C (T _J = 175 °C)	I _F	141	A
Repetitive Peak Forward Current (T _J = 175 °C)	I _{FRM}	423	A
Maximum Power Dissipation @ T _C = 80 °C (T _J = 175 °C)	P _{tot}	305	W
Minimum Operating Junction Temperature	T _{JMIN}	-40	°C
Maximum Operating Junction Temperature	T _{JMAX}	175	°C

START-UP DIODE (D15, D25)

Peak Repetitive Reverse Voltage	V _{RRM}	1200	V
Continuous Forward Current @ T _C = 80 °C (T _J = 175 °C)	I _F	78	A
Repetitive Peak Forward Current (T _J = 175 °C)	I _{FRM}	234	A

NXH500B100H7F5SHG

ABSOLUTE MAXIMUM RATINGS $T_J = 25\text{ }^\circ\text{C}$ unless otherwise noted (Note 2)

Rating	Symbol	Value	Unit
START-UP DIODE (D15, D25)			
Maximum Power Dissipation ($T_J = 175\text{ }^\circ\text{C}$)	P_{tot}	203	W
Minimum Operating Junction Temperature	T_{JMIN}	-40	$^\circ\text{C}$
Maximum Operating Junction Temperature	T_{JMAX}	175	$^\circ\text{C}$

Stresses exceeding those listed in the Maximum Ratings table may damage the device. If any of these limits are exceeded, device functionality should not be assumed, damage may occur and reliability may be affected.

2. Refer to ELECTRICAL CHARACTERISTICS, RECOMMENDED OPERATING RANGES and/or APPLICATION INFORMATION for Safe Operating parameters.

ELECTRICAL CHARACTERISTICS $T_J = 25\text{ }^\circ\text{C}$ unless otherwise noted

Parameter	Test Conditions	Symbol	Min	Typ	Max	Unit	
IGBT (T11, T12, T21, T22)							
Collector-Emitter Cutoff Current	$V_{GE} = 0\text{ V}, V_{CE} = 1000\text{ V}$	I_{CES}	-	-	500	μA	
Collector-Emitter Saturation Voltage	$V_{GE} = 15\text{ V}, I_C = 240\text{ A}, T_C = 25\text{ }^\circ\text{C}$	$V_{CE(SAT)}$	-	1.7	2.3	V	
	$V_{GE} = 15\text{ V}, I_C = 240\text{ A}, T_C = 150\text{ }^\circ\text{C}$		-	2.1	-		
Gate-Emitter Threshold Voltage	$V_{GE} = V_{CE}, I_C = 240\text{ mA}$	$V_{GE(TH)}$	4.0	5.7	6.9	V	
Gate Leakage Current	$V_{GE} = \pm 20\text{ V}, V_{CE} = 0\text{ V}$	I_{GES}	-	-	1	μA	
Internal Gate Resistor		R_g		1.5		Ω	
Turn-Off safe operating area	$V_{CC} < 800\text{ V},$ $R_{g,off} \geq 30\text{ }\Omega, T_{vj} < 150\text{ }^\circ\text{C}$			200		A	
Turn-On Delay Time	$T_J = 25\text{ }^\circ\text{C}, V_{CE} = 600\text{ V}, I_C = 100\text{ A}$ $V_{GE} = -9\text{ V}, +15\text{ V}, R_{G,on} = 7\text{ }\Omega,$ $R_{G,off} = 22\text{ }\Omega$	$t_{d(on)}$	-	132	-	ns	
Rise Time		t_r	-	30	-		
Turn-Off Delay Time		$t_{d(off)}$	-	400	-		
Fall time		t_f	-	29	-		
Turn on switching loss		E_{on}	-	1070	-		μJ
Turn off switching loss		E_{off}	-	3500	-		
Turn-On Delay Time	$T_J = 125\text{ }^\circ\text{C}, V_{CE} = 600\text{ V}, I_C = 100\text{ A}$ $V_{GE} = -9\text{ V}, +15\text{ V}, R_{G,on} = 7\text{ }\Omega,$ $R_{G,off} = 22\text{ }\Omega$	$t_{d(on)}$	-	127	-	ns	
Rise Time		t_r	-	33	-		
Turn-Off Delay Time		$t_{d(off)}$	-	460	-		
Fall time		t_f	-	40	-		
Turn on switching loss		E_{on}	-	1280	-		μJ
Turn off switching loss		E_{off}	-	5000	-		
Input capacitance	$V_{CE} = 20\text{ V}, V_{GE} = 0\text{ V}, f = 100\text{ kHz}$	C_{ies}	-	18488	-	μF	
Output capacitance		C_{oes}	-	797	-		
Reverse transfer capacitance		C_{res}	-	116	-		
Gate Charge	$V_{CE} = 600\text{ V}, V_{GE} = -15/+20\text{ V},$ $I_C = 40\text{ A}$	Q_g	-	1140	-	nC	
Thermal Resistance - chip-to-heatsink	Thermal grease, Thickness = 2.1 Mil \pm 2%, $\lambda = 2.9\text{ W/mK}$	R_{thJH}	-	0.263	-	K/W	
Thermal Resistance-chip-to-case		R_{thJC}	-	0.198	-	K/W	
IGBT INVERSE DIODE (D11, D12, D21, D22)							
Diode Forward Voltage	$I_F = 75\text{ A}, T_J = 25\text{ }^\circ\text{C}$	V_F	-	1.10	1.5	V	
	$I_F = 75\text{ A}, T_J = 150\text{ }^\circ\text{C}$		-	1.00	-		

NXH500B100H7F5SHG

ELECTRICAL CHARACTERISTICS $T_J = 25\text{ }^\circ\text{C}$ unless otherwise noted

Parameter	Test Conditions	Symbol	Min	Typ	Max	Unit
IGBT INVERSE DIODE (D11, D12, D21, D22)						
Surge Forward Current	$t_p = 10\text{ ms}, T_{vj} = 150\text{ }^\circ\text{C}$	I_{FSM}	–	500	–	A
I^2t	$t_p = 10\text{ ms}, T_{vj} = 150\text{ }^\circ\text{C}$	I^2t	–	1250	–	A^2s
Thermal Resistance-chip-to-heatsink	Thermal grease, Thickness = 2.1 Mil $\pm 2\%$ $\lambda = 2.9\text{ W/mK}$	R_{thJH}	–	0.61	–	K/W
Thermal Resistance-chip-to-case		R_{thJC}	–	0.47	–	

BOOST SILICON CARBIDE SCHOTTKY DIODE (D13, D14, D23, D24)

Reverse Leakage Current	$V_F = 1200\text{ V}, T_J = 25\text{ }^\circ\text{C}$	I_R	–	–	1.5	mA
Surge Forward Current	$t_p = 10\text{ ms}, T_{vj} = 150\text{ }^\circ\text{C}$	I_{FSM}	–	500	–	A
I^2t	$t_p = 10\text{ ms}, T_{vj} = 150\text{ }^\circ\text{C}$	I^2t	–	1250	–	A^2s
Diode Forward Voltage	$I_F = 120\text{ A}, T_J = 25\text{ }^\circ\text{C}$	V_F	–	1.45	1.7	V
	$I_F = 120\text{ A}, T_J = 150\text{ }^\circ\text{C}$		–	1.74	–	
Reverse Recovery Time	$T_J = 25\text{ }^\circ\text{C}$ $V_R = 600\text{ V}, I_C = 100\text{ A}$ $V_{GE} = -9\text{ V}, 15\text{ V}, R_{G,on} = 7\text{ }\Omega$	t_{rr}	–	25.5	–	ns
Reverse Recovery Charge		Q_{rr}	–	575	–	nC
Peak Reverse Recovery Current		I_{RRM}	–	33	–	A
Peak Rate of Fall of Recovery Current		di/dt	–	2800	–	$\text{A}/\mu\text{s}$
Reverse Recovery Energy		E_{rr}	–	270	–	μJ
Reverse Recovery Time		$T_J = 125\text{ }^\circ\text{C}$ $V_{DS} = 600\text{ V}, I_C = 100\text{ A}$ $V_{GE} = -9\text{ V}, 15\text{ V}, R_{G,on} = 7\text{ }\Omega$	t_{rr}	–	26	–
Reverse Recovery Charge	Q_{rr}		–	615	–	nC
Peak Reverse Recovery Current	I_{RRM}		–	36	–	A
Peak Rate of Fall of Recovery Current	di/dt		–	2550	–	$\text{A}/\mu\text{s}$
Reverse Recovery Energy	E_{rr}		–	279	–	μJ
Thermal Resistance-chip-to-heatsink	Thermal grease, Thickness = 2.1 Mil $\pm 2\%$ $\lambda = 2.9\text{ W/mK}$		R_{thJH}	–	0.405	–
Thermal Resistance-chip-to-case		R_{thJC}	–	0.316	–	K/W

START-UP DIODE (D15, D25)

Diode Forward Voltage	$I_F = 75\text{ A}, T_J = 25\text{ }^\circ\text{C}$	V_F	–	2.87	3.5	V
	$I_F = 75\text{ A}, T_J = 150\text{ }^\circ\text{C}$		–	2.19	–	
Surge Forward Current	$t_p = 10\text{ ms}, T_{vj} = 150\text{ }^\circ\text{C}$	I_{FSM}	–	450	–	A
I^2t	$t_p = 10\text{ ms}, T_{vj} = 150\text{ }^\circ\text{C}$	I^2t	–	1013	–	A^2s
Thermal Resistance-chip-to-heatsink	Thermal grease, Thickness = 2.1 Mil $\pm 2\%$ $\lambda = 2.9\text{ W/mK}$	R_{thJH}	–	0.61	–	K/W
Thermal Resistance-chip-to-case		R_{thJC}	–	0.47	–	K/W

THERMISTOR CHARACTERISTICS

Nominal resistance	$T = 25\text{ }^\circ\text{C}$	R_{25}	–	5	–	$\text{k}\Omega$
Nominal resistance	$T = 100\text{ }^\circ\text{C}$	R_{100}	–	492.2	–	Ω
Deviation of R_{25}		$\Delta R/R$	-1	–	1	%
Power dissipation		P_D	–	5	–	mW
Power dissipation constant			–	1.3	–	mW/K
B-value	$B(25/85)$, tolerance $\pm 1\%$		–	3430	–	K

Product parametric performance is indicated in the Electrical Characteristics for the listed test conditions, unless otherwise noted. Product performance may not be indicated by the Electrical Characteristics if operated under different conditions.

NXH500B100H7F5SHG

ORDERING INFORMATION

Orderable Part Number	Marking	Package	Shipping
NXH500B100H7F5SHG	NXH500B100H7F5SHG	F5-PIM58 112x62 (Solder PIN) (Pb-Free and Halide-Free, Solder Pins)	8 Units / Blister Tray

NXH500B100H7F5SHG

TYPICAL CHARACTERISTICS – T11, T12, T21, T22 (IGBT)

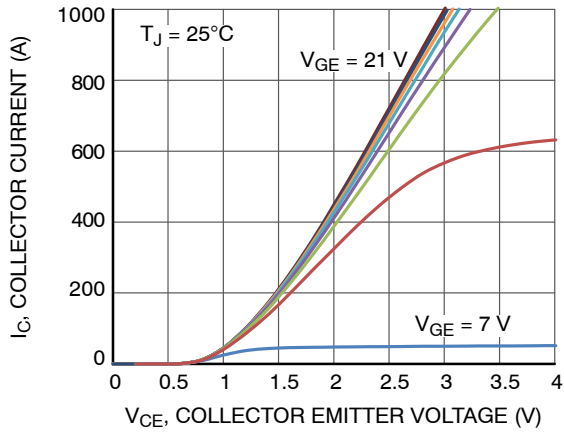

Figure 2. Typical Output Characteristics – IGBT

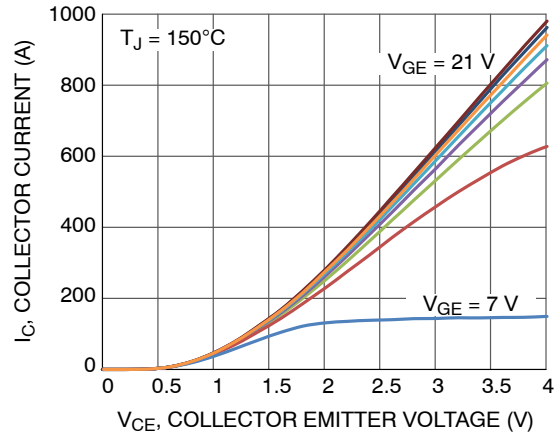

Figure 3. Typical Output Characteristics – IGBT

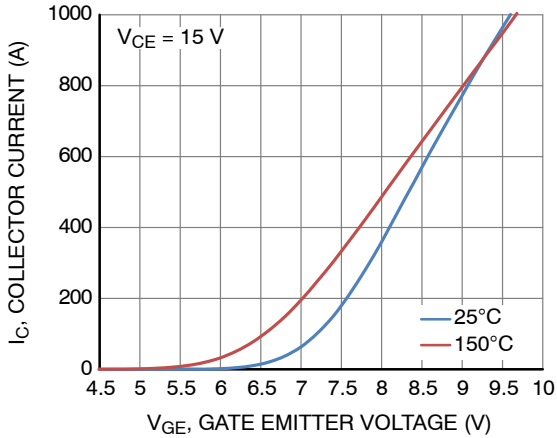

Figure 4. Transfer Characteristics – IGBT

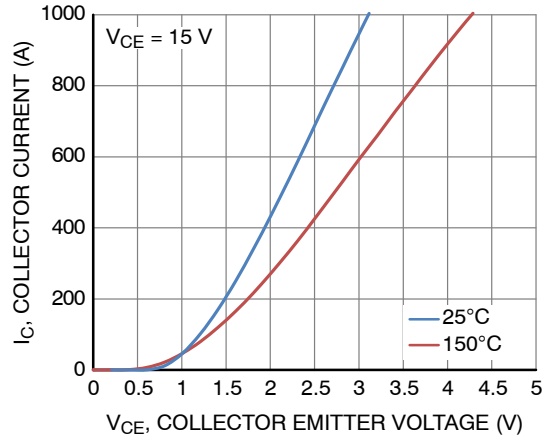

Figure 5. Saturation Voltage Characteristic – IGBT

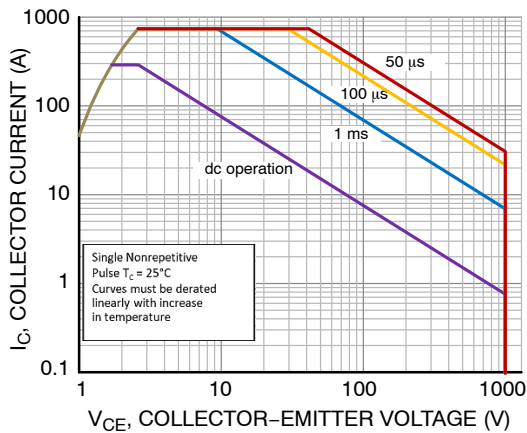

Figure 6. FBSOA

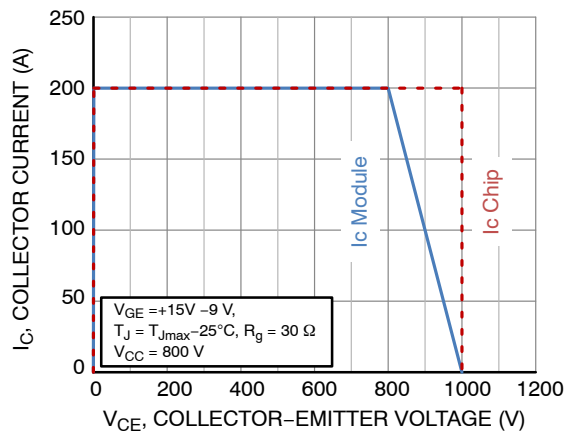

Figure 7. RBSOA

NXH500B100H7F5SHG

TYPICAL CHARACTERISTICS – T11, T12, T21, T22 (IGBT) (continued)

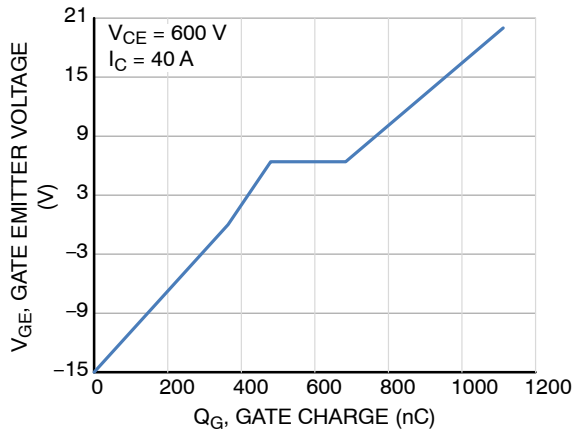

Figure 8. Gate Voltage vs. Gate Charge

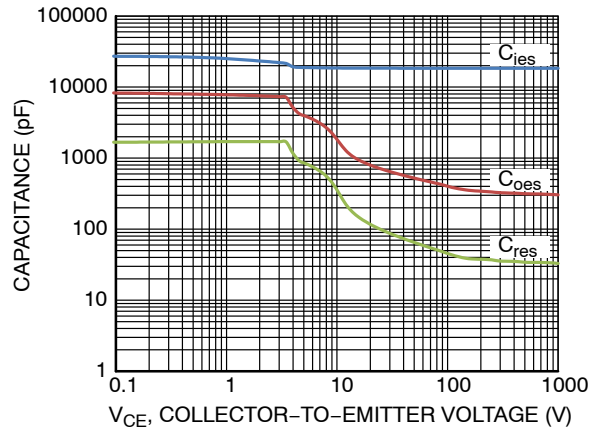

Figure 9. Capacitance vs. V_{CE}

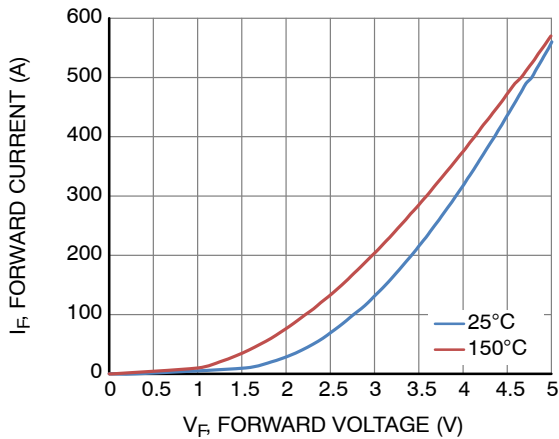

Figure 10. Start-up Diode Forward Characteristics

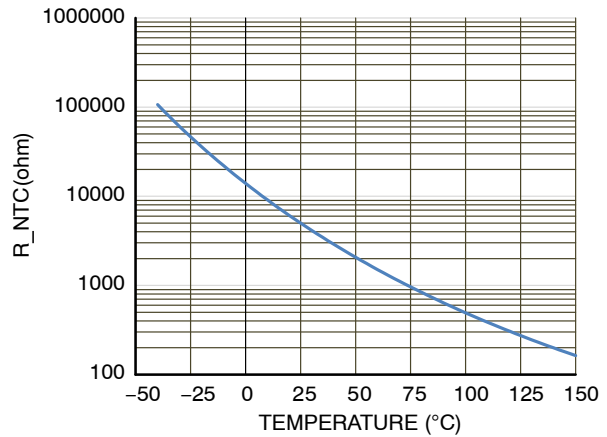

Figure 11. Thermistor Characteristic

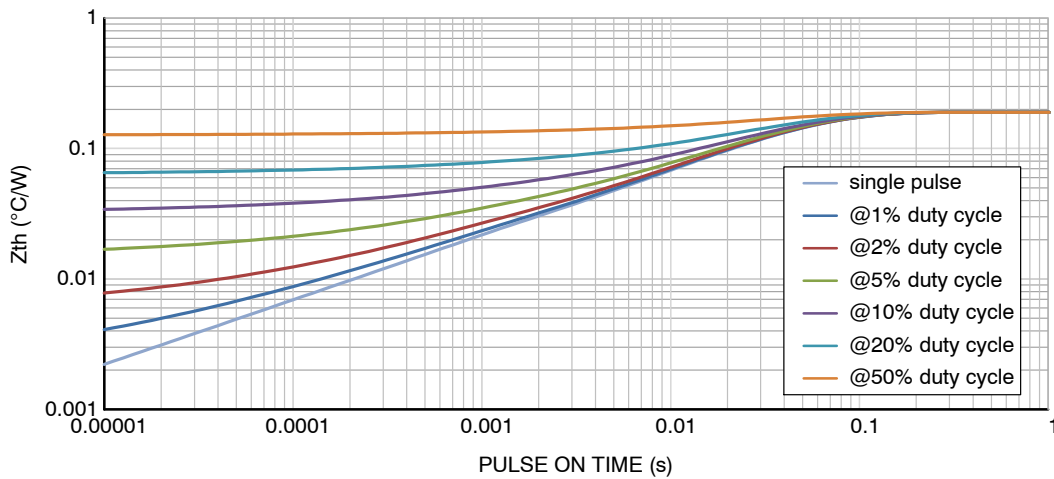

Figure 12. MOSFET Junction-to-Case Transient Thermal Impedance

NXH500B100H7F5SHG

TYPICAL CHARACTERISTIC – D11,D12,D21,D22 (INVERSE DIODE)

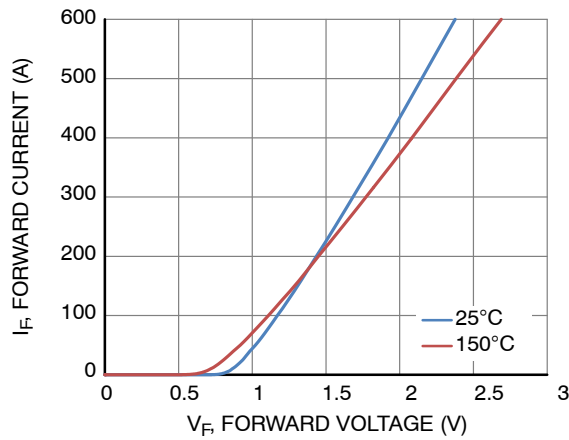

Figure 13. Inverse Diode Forward Characteristics

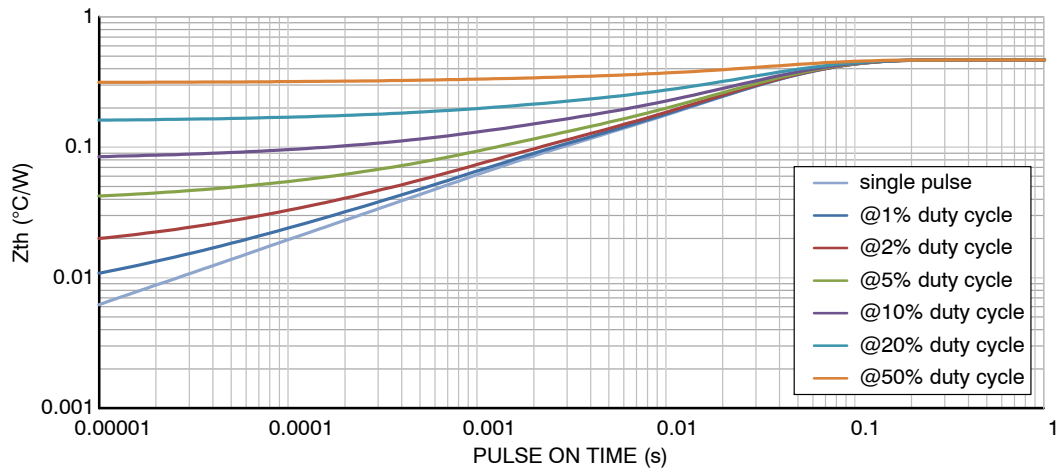

Figure 14. Transient Thermal Impedance (Inverse Diode Z_{thjc})

NXH500B100H7F5SHG

TYPICAL CHARACTERISTIC – D13,D14,D23,D24 (SiC SCHOTTKY DIODE)

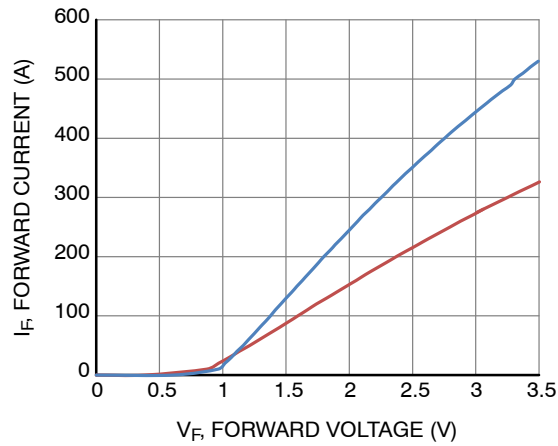

Figure 15. SiC Schottky Diode Forward Characteristics

TYPICAL CHARACTERISTIC – D13,D14,D23,D24 (SiC SCHOTTKY DIODE) (continued)

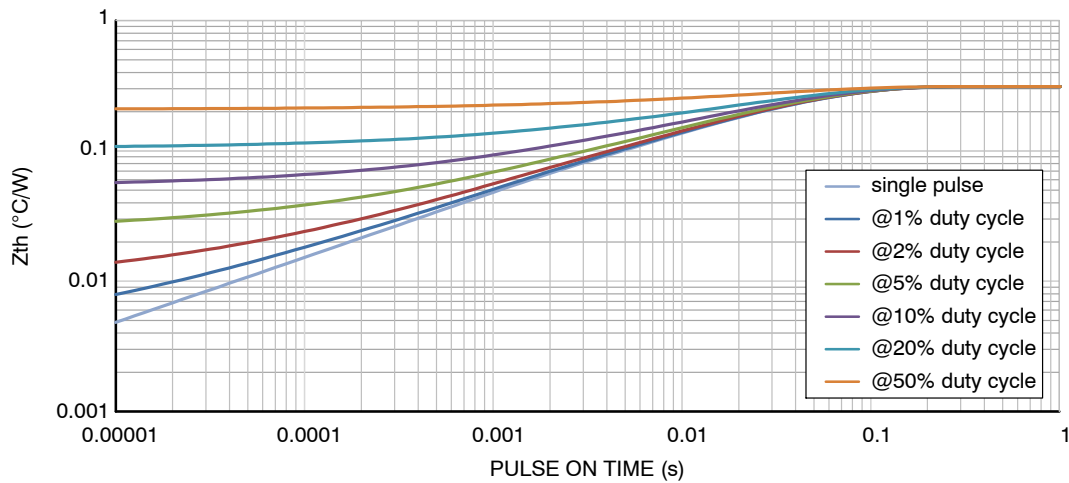

Figure 16. Transient Thermal Impedance (SiC Schottky Diode Z_{thjc})

NXH500B100H7F5SHG

TYPICAL CHARACTERISTICS – D15, D25 DIODE

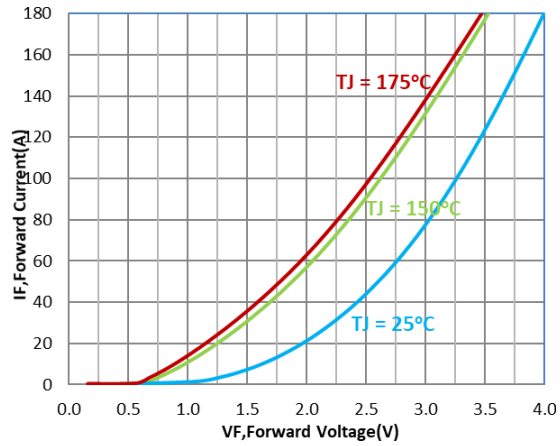

Figure 17. Diode Forward Characteristics

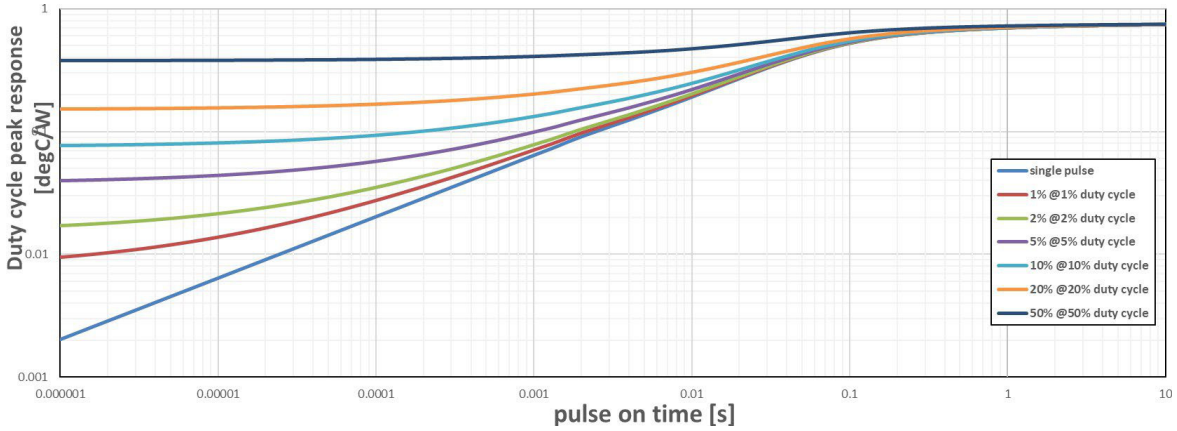

Figure 18. Transient Thermal Impedance (Rthjh)

TYPICAL CHARACTERISTICS – T11, T12, T21, T22 (IGBT)

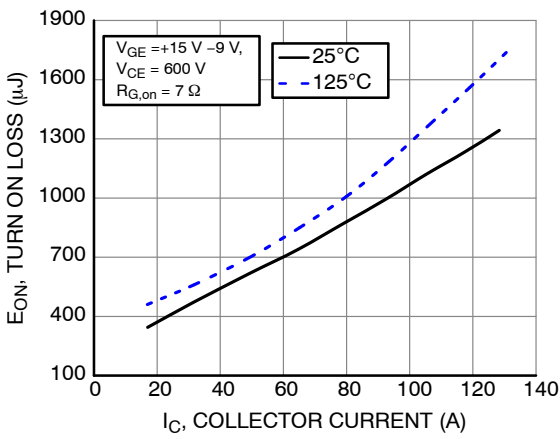

Figure 19. Typical Turn On Loss vs. I_C

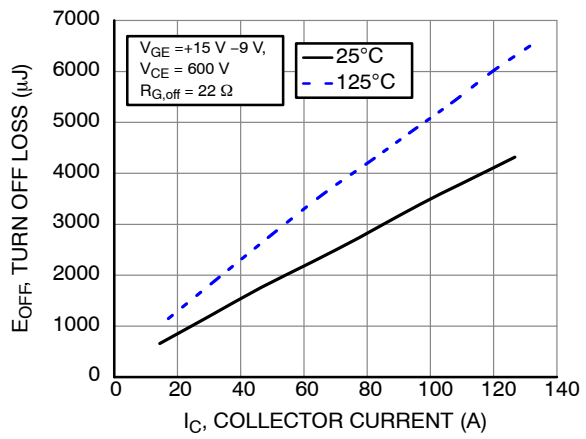

Figure 20. Typical Turn Off Loss vs. I_C

NXH500B100H7F5SHG

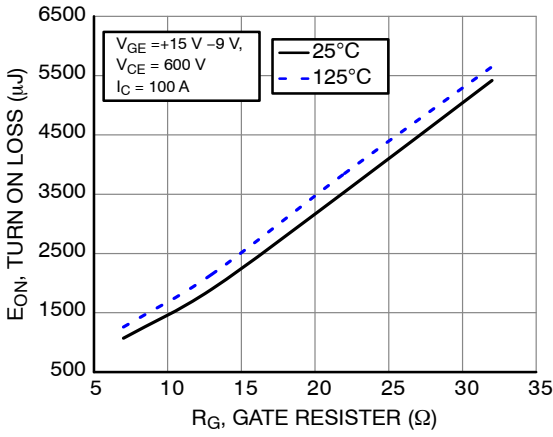

Figure 21. Typical Turn On Loss vs. R_G

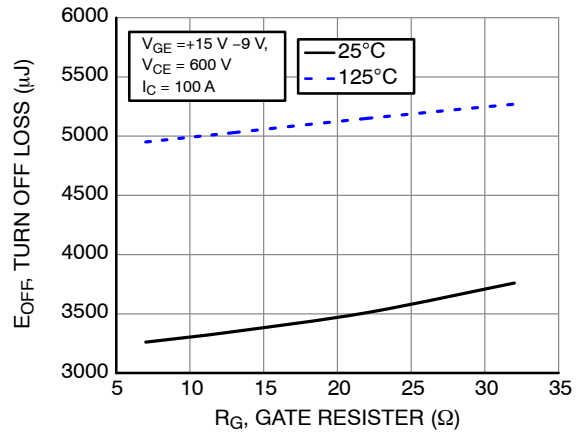

Figure 22. Typical Turn Off Loss vs. R_G

TYPICAL CHARACTERISTICS – T11, T12, T21, T22 (IGBT) (continued)

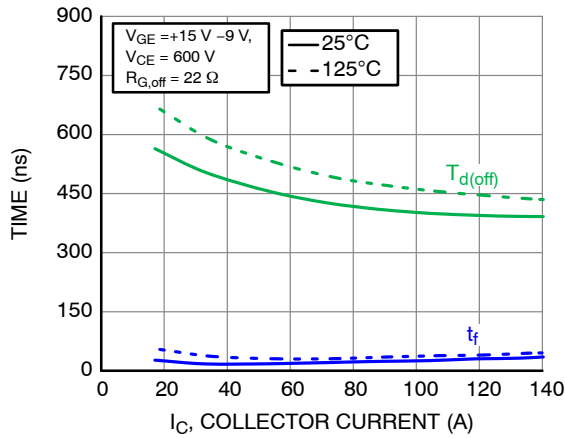

Figure 23. Typical Turn Off Switching Time vs. I_C

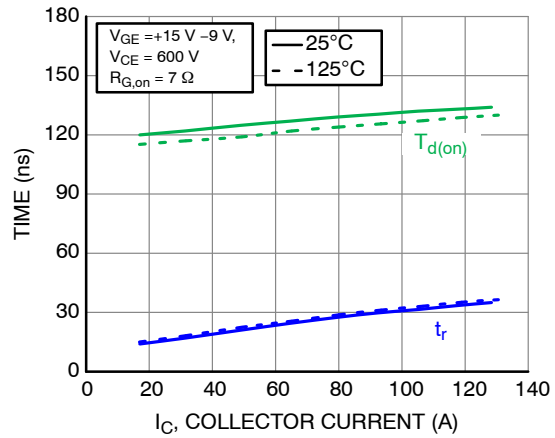

Figure 24. Typical Turn On Switching Time vs. I_C

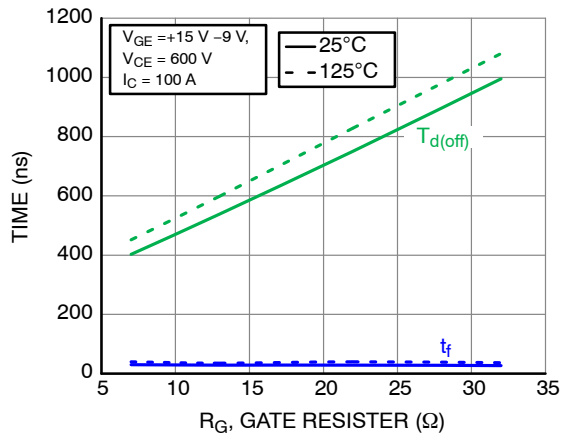

Figure 25. Typical Turn Off Switching Time vs. R_G

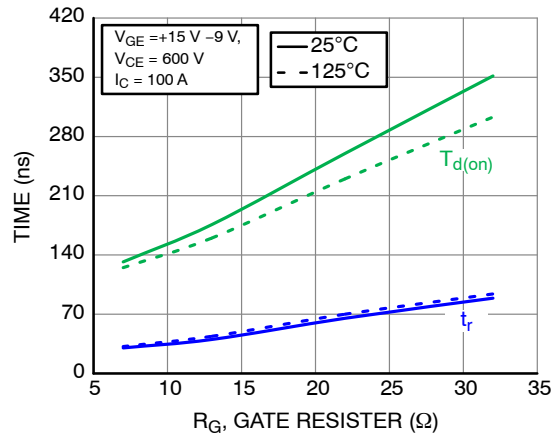

Figure 26. Typical Turn On Switching Time vs. R_G

TYPICAL CHARACTERISTICS – SIC SCHOTTKY DIODE (D13,D14,D23,D24)

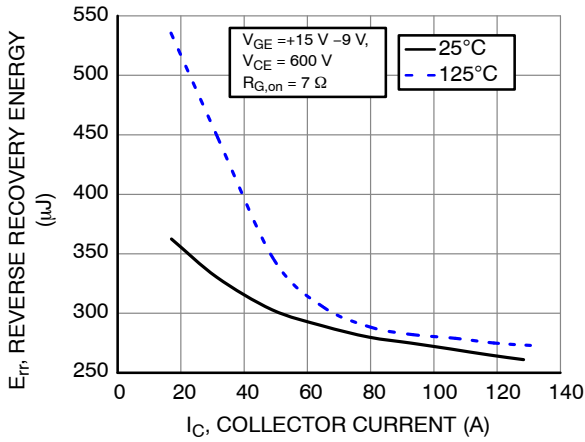

Figure 27. Typical Reverse Recovery Energy Loss vs. I_C

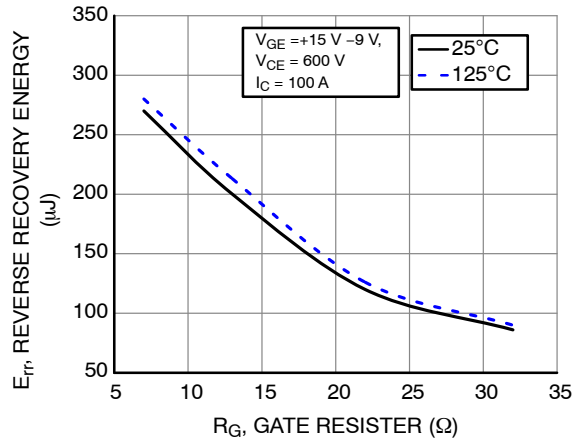

Figure 28. Typical Reverse Recovery Energy Loss vs. R_G

TYPICAL CHARACTERISTICS – SIC SCHOTTKY DIODE (D13,D14,D23,D24) (continued)

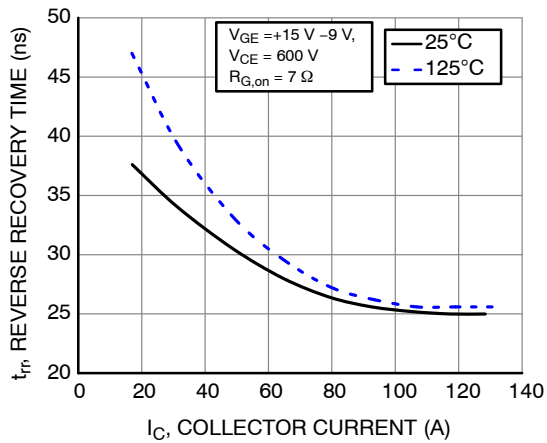

Figure 29. Typical Reverse Recovery Time vs. I_C

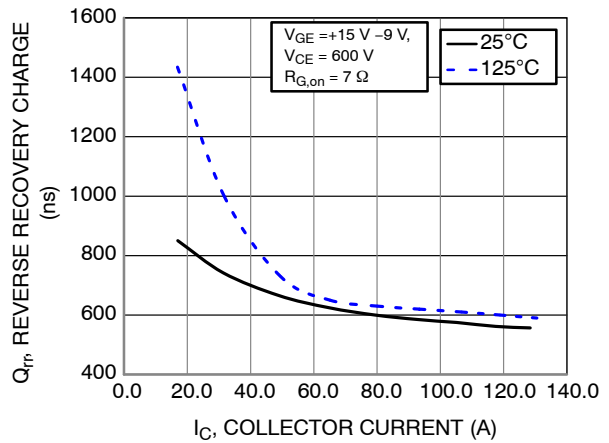

Figure 30. Typical Reverse Recovery Charge vs. I_C

NXH500B100H7F5SHG

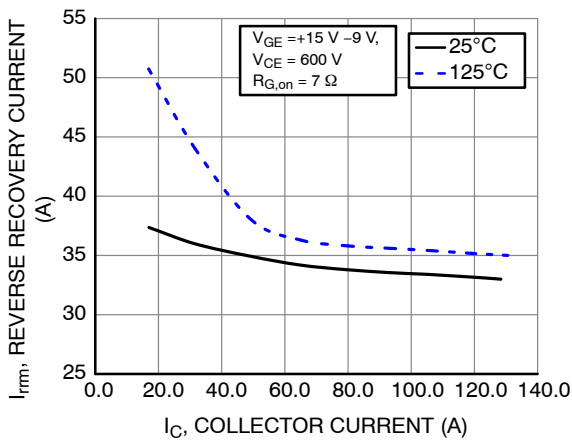

Figure 31. Typical Reverse Recovery Current vs. I_C

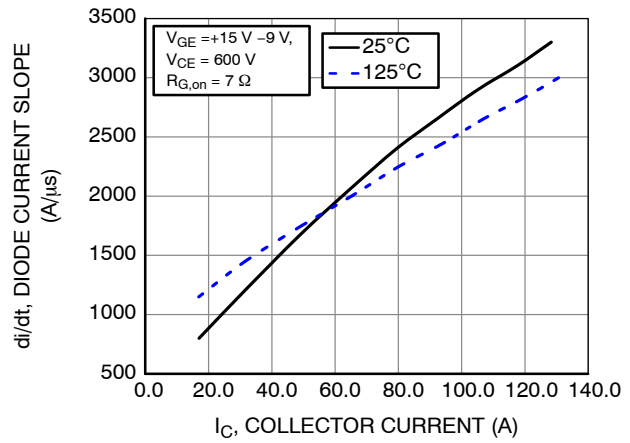

Figure 32. Typical Diode Current Slope vs. I_C

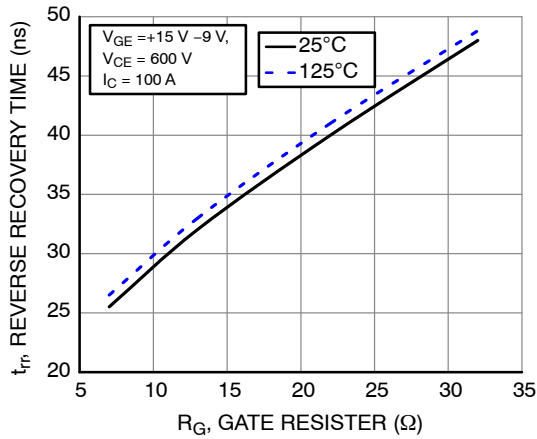

Figure 33. Typical Reverse Recovery Time vs. R_G

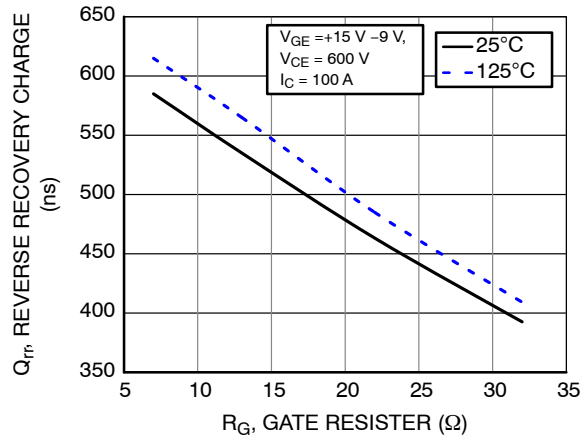

Figure 34. Typical Reverse Recovery Charge vs. R_G

TYPICAL CHARACTERISTICS – SIC SCHOTTKY DIODE (D13,D14,D23,D24) (continued)

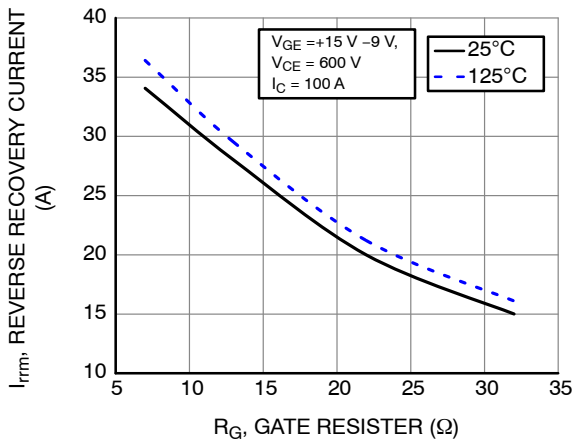

Figure 35. Typical Reverse Recovery Time vs. I_C

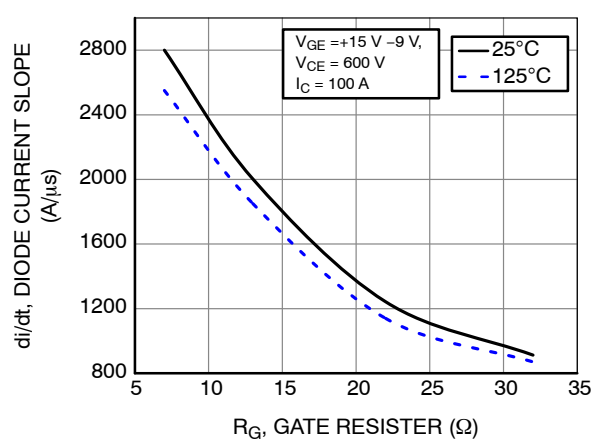
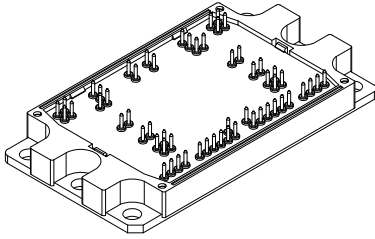

Figure 36. Typical Reverse Recovery Charge vs. I_C

NXH500B100H7F5SHG

REVISION HISTORY

Revision	Description of Changes	Date
0	Initial document version release	9/17/2025



PIM58 112.00x62.00x12.00
CASE 180CZ
ISSUE O

DATE 30 JUL 2024

NOTES:

1. Dimensioning and tolerancing conform to ASME Y14.5
2. All dimensions are in millimeters.
3. Pin-grid is 3.2mm.
4. Package marking is located on the side opposite the package orientation feature.
5. The pins are gold-plated solder pin.

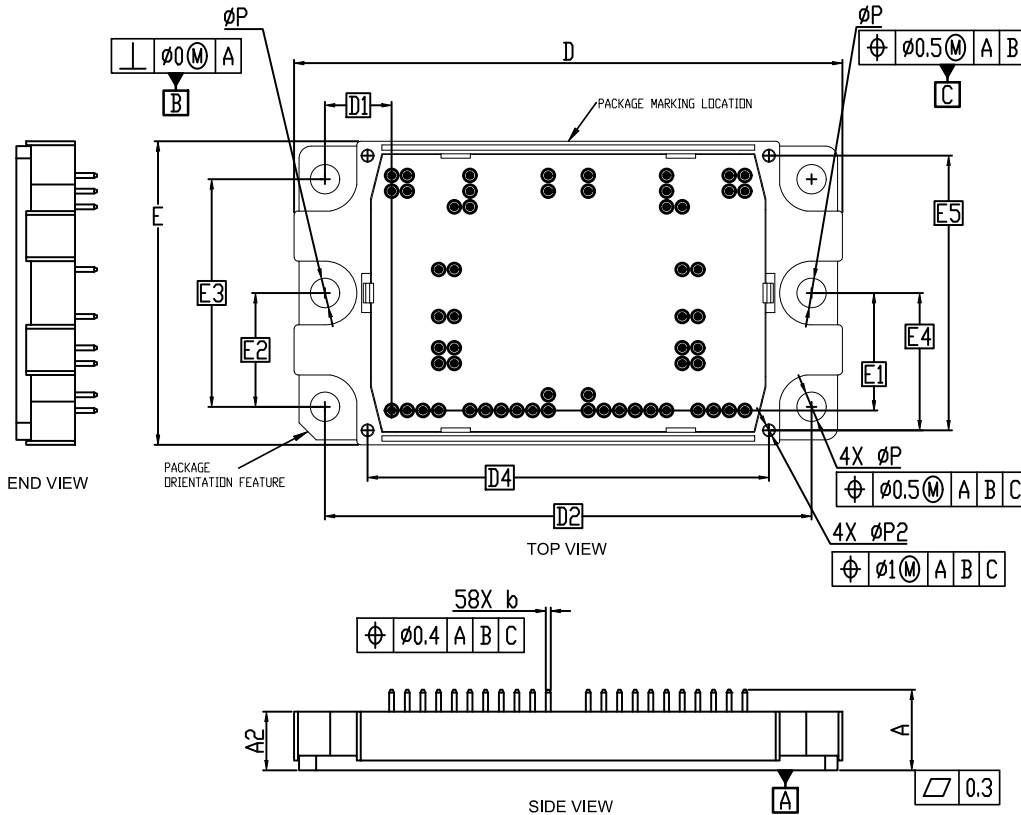

DIM	MILLIMETERS		
	MIN.	NOM.	MAX.
A	16.10	16.50	16.90
A2	11.70	12.00	12.30
b	0.95	1.00	1.05
D	111.60	112.00	112.40
D1	13.62 BSC		
D2	99.40 BSC		
D4	82.00 BSC		
E	61.60	62.00	62.40
E1	24.00 BSC		
E2	23.25 BSC		
E3	46.50 BSC		
E4	28.05 BSC		
E5	56.10 BSC		
P	5.90	6.00	6.10
P2	2.20	2.30	2.40

END VIEW

PACKAGE ORIENTATION FEATURE

TOP VIEW

SIDE VIEW

DOCUMENT NUMBER:	98AON62471H	Electronic versions are uncontrolled except when accessed directly from the Document Repository. Printed versions are uncontrolled except when stamped "CONTROLLED COPY" in red.
DESCRIPTION:	PIM58 112.00x62.00x12.00	PAGE 1 OF 2

onsemi and ONSEMI are trademarks of Semiconductor Components Industries, LLC dba onsemi or its subsidiaries in the United States and/or other countries. onsemi reserves the right to make changes without further notice to any products herein. onsemi makes no warranty, representation or guarantee regarding the suitability of its products for any particular purpose, nor does onsemi assume any liability arising out of the application or use of any product or circuit, and specifically disclaims any and all liability, including without limitation special, consequential or incidental damages. onsemi does not convey any license under its patent rights nor the rights of others.

PIM58 112.00x62.00x12.00
CASE 180CZ
ISSUE O

DATE 30 JUL 2024

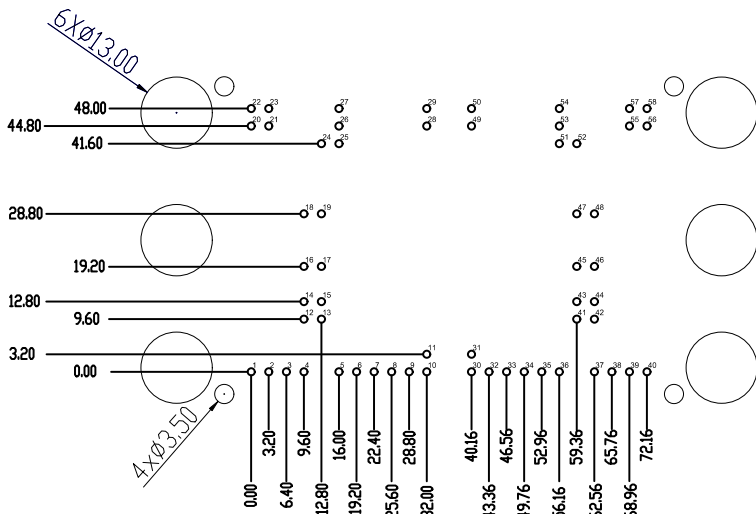

RECOMMENDED MOUNTING PATTERN

* For additional information on our Pb-Free strategy and soldering details, please download the Onsemi Soldering and Mounting Techniques Reference Manual, SOLDERM/D.

NOTE 2:

Pin table								
Pin	X	Y	Pin	X	Y	Pin	X	Y
1	0	0	24	12.8	41.6	47	59.36	28.8
2	3.2	0	25	16	41.6	48	62.56	28.8
3	6.4	0	26	16	44.8	49	40.16	44.8
4	9.6	0	27	16	48	50	40.16	48
5	16	0	28	32	44.8	51	56.16	41.6
6	19.2	0	29	32	48	52	59.36	41.6
7	22.4	0	30	40.16	0	53	56.16	44.8
8	25.6	0	31	40.16	3.2	54	56.16	48
9	28.8	0	32	43.36	0	55	68.96	44.8
10	32	0	33	46.56	0	56	72.16	44.8
11	32	3.2	34	49.76	0	57	68.96	48
12	9.6	9.6	35	52.96	0	58	72.16	48
13	12.8	9.6	36	56.16	0			
14	9.6	12.8	37	62.56	0			
15	12.8	12.8	38	65.76	0			
16	9.6	19.2	39	68.96	0			
17	12.8	19.2	40	72.16	0			
18	9.6	28.8	41	59.36	9.6			
19	12.8	28.8	42	62.56	9.6			
20	0	44.8	43	59.36	12.8			
21	3.2	44.8	44	62.56	12.8			
22	0	48	45	59.36	19.2			
23	3.2	48	46	62.56	19.2			

GENERIC MARKING DIAGRAM*

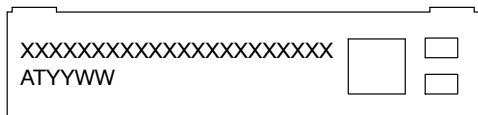

FRONTSIDE MARKING

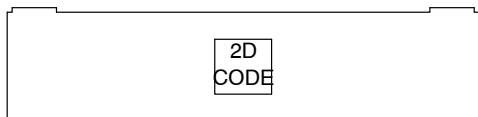

BACKSIDE MARKING

XXXXX = Specific Device Code
AT = Assembly & Test Site Code
YYWW = Year and Work Week Code

*This information is generic. Please refer to device data sheet for actual part marking. Pb-Free indicator, "G" or microdot "▪", may or may not be present. Some products may not follow the Generic Marking.

DOCUMENT NUMBER:	98AON62471H	Electronic versions are uncontrolled except when accessed directly from the Document Repository. Printed versions are uncontrolled except when stamped "CONTROLLED COPY" in red.
DESCRIPTION:	PIM58 112.00x62.00x12.00	PAGE 2 OF 2

onsemi and ONSEMI are trademarks of Semiconductor Components Industries, LLC dba onsemi or its subsidiaries in the United States and/or other countries. onsemi reserves the right to make changes without further notice to any products herein. onsemi makes no warranty, representation or guarantee regarding the suitability of its products for any particular purpose, nor does onsemi assume any liability arising out of the application or use of any product or circuit, and specifically disclaims any and all liability, including without limitation special, consequential or incidental damages. onsemi does not convey any license under its patent rights nor the rights of others.

onsemi, **Onsemi**, and other names, marks, and brands are registered and/or common law trademarks of Semiconductor Components Industries, LLC dba "**onsemi**" or its affiliates and/or subsidiaries in the United States and/or other countries. **onsemi** owns the rights to a number of patents, trademarks, copyrights, trade secrets, and other intellectual property. A listing of **onsemi**'s product/patent coverage may be accessed at www.onsemi.com/site/pdf/Patent-Marking.pdf. **onsemi** reserves the right to make changes at any time to any products or information herein, without notice. The information herein is provided "as-is" and **onsemi** makes no warranty, representation or guarantee regarding the accuracy of the information, product features, availability, functionality, or suitability of its products for any particular purpose, nor does **onsemi** assume any liability arising out of the application or use of any product or circuit, and specifically disclaims any and all liability, including without limitation special, consequential or incidental damages. Buyer is responsible for its products and applications using **onsemi** products, including compliance with all laws, regulations and safety requirements or standards, regardless of any support or applications information provided by **onsemi**. "Typical" parameters which may be provided in **onsemi** data sheets and/or specifications can and do vary in different applications and actual performance may vary over time. All operating parameters, including "Typicals" must be validated for each customer application by customer's technical experts. **onsemi** does not convey any license under any of its intellectual property rights nor the rights of others. **onsemi** products are not designed, intended, or authorized for use as a critical component in life support systems or any FDA Class 3 medical devices or medical devices with a same or similar classification in a foreign jurisdiction or any devices intended for implantation in the human body. Should Buyer purchase or use **onsemi** products for any such unintended or unauthorized application, Buyer shall indemnify and hold **onsemi** and its officers, employees, subsidiaries, affiliates, and distributors harmless against all claims, costs, damages, and expenses, and reasonable attorney fees arising out of, directly or indirectly, any claim of personal injury or death associated with such unintended or unauthorized use, even if such claim alleges that **onsemi** was negligent regarding the design or manufacture of the part. **onsemi** is an Equal Opportunity/Affirmative Action Employer. This literature is subject to all applicable copyright laws and is not for resale in any manner.

ADDITIONAL INFORMATION

TECHNICAL PUBLICATIONS:

Technical Library: www.onsemi.com/design/resources/technical-documentation
onsemi Website: www.onsemi.com

ONLINE SUPPORT: www.onsemi.com/support

For additional information, please contact your local Sales Representative at www.onsemi.com/support/sales