

# EEPROM Serial 8/16-Kb SPI - Automotive Grade 1 in Wettable Flank UDFN8 Package

## NV25080MUW, NV25160MUW

### Description

The NV25080/25160 are EEPROM Serial 8/16-Kb SPI – Automotive Grade 1 devices internally organized as 1024x8/2048x8 bits. They feature a 32-byte page write buffer and support the Serial Peripheral Interface (SPI) protocol. The device is enabled through a Chip Select ( $\overline{CS}$ ) input. In addition, the required bus signals are a clock input (SCK), data input (SI) and data output (SO) lines. The  $\overline{HOLD}$  input may be used to pause any serial communication with the NV25080/25160 device. These devices feature software and hardware write protection, including partial as well as full array protection.

### Features

- Automotive AEC-Q100 Grade 1 (–40°C to +125°C) Qualified
- 10 MHz SPI Compatible
- 1.8 V to 5.5 V Supply Voltage Range
- SPI Modes (0,0) & (1,1)
- 32-byte Page Write Buffer
- Self-timed Write Cycle
- Hardware and Software Protection
- Block Write Protection
  - Protect 1/4, 1/2 or Entire EEPROM Array
- Low Power CMOS Technology
- 1,000,000 Program/Erase Cycles
- 100 Year Data Retention
- Industrial and Extended Temperature Range
- 8-Pad Wettable Flank UDFN8 Packages
- These Devices are Pb-Free, Halogen Free/BFR Free, and RoHS Compliant

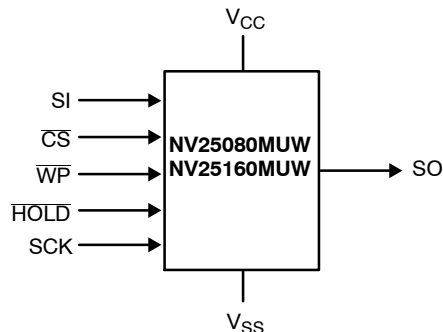

Figure 1. Functional Symbol



UDFN8 (2x2)  
(Wettable Flank)  
MUW2 SUFFIX  
CASE 517AW



UDFN8 (2x3)  
(Wettable Flank)  
MUW3 SUFFIX  
CASE 517DH

### PIN CONFIGURATIONS

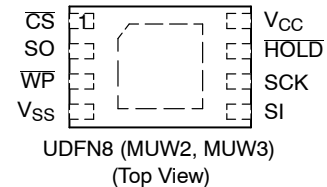

### PIN FUNCTION

Pin Name	Function
$\overline{CS}$	Chip Select
SO	Serial Data Output
$\overline{WP}$	Write Protect
V <sub>SS</sub>	Ground
SI	Serial Data Input
SCK	Serial Clock
$\overline{HOLD}$	Hold Transmission Input
V <sub>CC</sub>	Power Supply

### ORDERING INFORMATION

See detailed ordering and shipping information on page 11 of this data sheet.

# NV25080MUW, NV25160MUW

**Table 1. ABSOLUTE MAXIMUM RATINGS**

Parameters	Ratings	Unit
Operating Temperature	-45 to +130	°C
Storage Temperature	-65 to +150	°C
Voltage on any Pin with Respect to Ground (Note 1)	-0.5 to +6.5	V

Stresses exceeding those listed in the Maximum Ratings table may damage the device. If any of these limits are exceeded, device functionality should not be assumed, damage may occur and reliability may be affected.

- The DC input voltage on any pin should not be lower than -0.5 V or higher than  $V_{CC} + 0.5$  V. During transitions, the voltage on any pin may undershoot to no less than -1.5 V or overshoot to no more than  $V_{CC} + 1.5$  V, for periods of less than 20 ns.

**Table 2. RELIABILITY CHARACTERISTICS** (Note 2)

Symbol	Parameter	Min	Unit
$N_{END}$ (Note 3)	Endurance	1,000,000	Program / Erase Cycles
$T_{DR}$	Data Retention	100	Years

- These parameters are tested initially and after a design or process change that affects the parameter according to appropriate AEC-Q100 and JEDEC test methods.
- Page Mode,  $V_{CC} = 5$  V, 25°C.

**Table 3. DC OPERATING CHARACTERISTICS** ( $V_{CC} = 1.8$  V to 5.5 V,  $T_A = -40$ °C to +125°C, unless otherwise specified.)

Symbol	Parameter	Test Conditions	Min	Max	Unit
$I_{CCR}$	Supply Current (Read Mode)	Read, $V_{CC} = 5.5$ V, 5 MHz, SO open		2	mA
$I_{CCW}$	Supply Current (Write Mode)	Write, $V_{CC} = 5.5$ V, 5 MHz, SO open		3	mA
$I_{SB1}$	Standby Current	$V_{IN} = GND$ or $V_{CC}$ , $\overline{CS} = V_{CC}$ , $\overline{WP} = V_{CC}$ , $V_{CC} = 5.5$ V		2	μA
$I_{SB2}$	Standby Current	$V_{IN} = GND$ or $V_{CC}$ , $\overline{CS} = V_{CC}$ , $\overline{WP} = GND$ , $V_{CC} = 5.5$ V		5	μA
$I_L$	Input Leakage Current	$V_{IN} = GND$ or $V_{CC}$	-2	2	μA
$I_{LO}$	Output Leakage Current	$\overline{CS} = V_{CC}$ , $V_{OUT} = GND$ or $V_{CC}$	-1	2	μA
$V_{IL1}$	Input Low Voltage	$V_{CC} \geq 2.5$ V	-0.5	$0.3 V_{CC}$	V
$V_{IH1}$	Input High Voltage	$V_{CC} \geq 2.5$ V	$0.7 V_{CC}$	$V_{CC} + 0.5$	V
$V_{IL2}$	Input Low Voltage	$V_{CC} < 2.5$ V	-0.5	$0.2 V_{CC}$	V
$V_{IH2}$	Input High Voltage	$V_{CC} < 2.5$ V	$0.8 V_{CC}$	$V_{CC} + 0.5$	V
$V_{OL1}$	Output Low Voltage	$I_{OL} = 3.0$ mA		0.4	V
$V_{OH1}$	Output High Voltage	$I_{OH} = -1.6$ mA	$V_{CC} - 0.8$ V		V

Product parametric performance is indicated in the Electrical Characteristics for the listed test conditions, unless otherwise noted. Product performance may not be indicated by the Electrical Characteristics if operated under different conditions.

**Table 4. PIN CAPACITANCE** ( $T_A = 25$ °C,  $f = 1.0$  MHz,  $V_{CC} = +5.0$  V) (Note 2)

Symbol	Test	Conditions	Min	Typ	Max	Unit
$C_{OUT}$	Output Capacitance (SO)	$V_{OUT} = 0$ V			8	pF
$C_{IN}$	Input Capacitance ( $\overline{CS}$ , SCK, SI, $\overline{WP}$ , HOLD)	$V_{IN} = 0$ V			8	pF

# NV25080MUW, NV25160MUW

**Table 5. AC CHARACTERISTICS** ( $T_A = -40^\circ\text{C}$  to  $+125^\circ\text{C}$ ) (Note 4)

Symbol	Parameter	$V_{CC} = 1.8\text{ V} - 5.5\text{ V}$		$V_{CC} = 2.5\text{ V} - 5.5\text{ V}$		Unit
		Min	Max	Min	Max	
$f_{SCK}$	Clock Frequency	DC	5	DC	10	MHz
$t_{SU}$	Data Setup Time	20		10		ns
$t_H$	Data Hold Time	20		10		ns
$t_{WH}$	SCK High Time	75		40		ns
$t_{WL}$	SCK Low Time	75		40		ns
$t_{LZ}$	HOLD to Output Low Z		50		25	ns
$t_{RI}$ (Note 5)	Input Rise Time		2		2	$\mu\text{s}$
$t_{FI}$ (Note 5)	Input Fall Time		2		2	$\mu\text{s}$
$t_{HD}$	$\overline{\text{HOLD}}$ Setup Time	0		0		ns
$t_{CD}$	$\overline{\text{HOLD}}$ Hold Time	10		10		ns
$t_V$	Output Valid from Clock Low		80		35	ns
$t_{HO}$	Output Hold Time	0		0		ns
$t_{DIS}$	Output Disable Time		50		20	ns
$t_{HZ}$	$\overline{\text{HOLD}}$ to Output High Z		100		25	ns
$t_{CS}$	$\overline{\text{CS}}$ High Time	80		40		ns
$t_{CSS}$	$\overline{\text{CS}}$ Setup Time	60		30		ns
$t_{CSH}$	$\overline{\text{CS}}$ Hold Time	60		30		ns
$t_{CNS}$	$\overline{\text{CS}}$ Inactive Setup Time	60		20		ns
$t_{CNH}$	$\overline{\text{CS}}$ Inactive Hold Time	60		20		ns
$t_{WPS}$	WP Setup Time	10		10		ns
$t_{WPH}$	$\overline{\text{WP}}$ Hold Time	15		15		ns
$t_{WC}$ (Note 6)	Write Cycle Time		5		5	ms

4. AC Test Conditions:

Input Pulse Voltages:  $0.3 V_{CC}$  to  $0.7 V_{CC}$  at  $V_{CC} = 2.5\text{ V} - 5.5\text{ V}$  and  $0.2 V_{CC}$  to  $0.8\text{ V}$  at  $V_{CC} = 1.8\text{ V} - 2.5\text{ V}$ .

Input rise and fall times:  $\leq 10\text{ ns}$

Input and output reference voltages:  $0.5 V_{CC}$

Output load: current source  $I_{OL\text{ max}}/I_{OH\text{ max}}$ ;  $C_L = 30\text{ pF}$

5. This parameter is tested initially and after a design or process change that affects the parameter.

6.  $t_{WC}$  is the time from the rising edge of  $\overline{\text{CS}}$  after a valid write sequence to the end of the internal write cycle.

**Table 6. POWER-UP TIMING** (Notes 5, 7)

Symbol	Parameter	Min	Max	Unit
$t_{PUR}$	Power-up to Read Operation	0.1	1	ms
$t_{PUW}$	Power-up to Write Operation	0.1	1	ms

7.  $t_{PUR}$  and  $t_{PUW}$  are the delays required from the time  $V_{CC}$  is stable until the specified operation can be initiated.

**PIN DESCRIPTION**

**SI:** The serial data input pin accepts op-codes, addresses and data. In SPI modes (0,0) and (1,1) input data is latched on the rising edge of the SCK clock input.

**SO:** The serial data output pin is used to transfer data out of the device. In SPI modes (0,0) and (1,1) data is shifted out on the falling edge of the SCK clock.

**SCK:** The serial clock input pin accepts the clock provided by the host and used for synchronizing communication between host and NV25080/160.

**CS:** The chip select input pin is used to enable/disable the NV25080/160. When CS is high, the SO output is tri-stated (high impedance) and the device is in Standby Mode (unless an internal write operation is in progress). Every communication session between host and NV25080/160 must be preceded by a high to low transition and concluded with a low to high transition of the CS input.

**WP:** The write protect input pin will allow all write operations to the device when held high. When WP pin is tied low and the WPEN bit in the Status Register (refer to Status Register description, later in this Data Sheet) is set to “1”, writing to the Status Register is disabled.

**HOLD:** The HOLD input pin is used to pause transmission between host and NV25080/160, without having to retransmit the entire sequence at a later time. To pause, HOLD must be taken low and to resume it must be taken back high, with the SCK input low during both transitions.

When not used for pausing, the HOLD input should be tied to VCC, either directly or through a resistor.

**Functional Description**

The NV25080/160 devices support the Serial Peripheral Interface (SPI) bus protocol, modes (0,0) and (1,1). The device contains an 8-bit instruction register. The instruction set and associated op-codes are listed in Table 7.

Reading data stored in the NV25080/160 is accomplished by simply providing the READ command and an address. Writing to the NV25080/160, in addition to a WRITE command, address and data, also requires enabling the device for writing by first setting certain bits in a Status Register, as will be explained later.

After a high to low transition on the CS input pin, the NV25080/160 will accept any one of the six instruction op-codes listed in Table 7 and will ignore all other possible 8-bit combinations. The communication protocol follows the timing from Figure 2.

**Table 7. INSTRUCTION SET**

Instruction	Opcode	Operation
WREN	0000 0110	Enable Write Operations
WRDI	0000 0100	Disable Write Operations
RDSR	0000 0101	Read Status Register
WRSR	0000 0001	Write Status Register
READ	0000 0011	Read Data from Memory
WRITE	0000 0010	Write Data to Memory

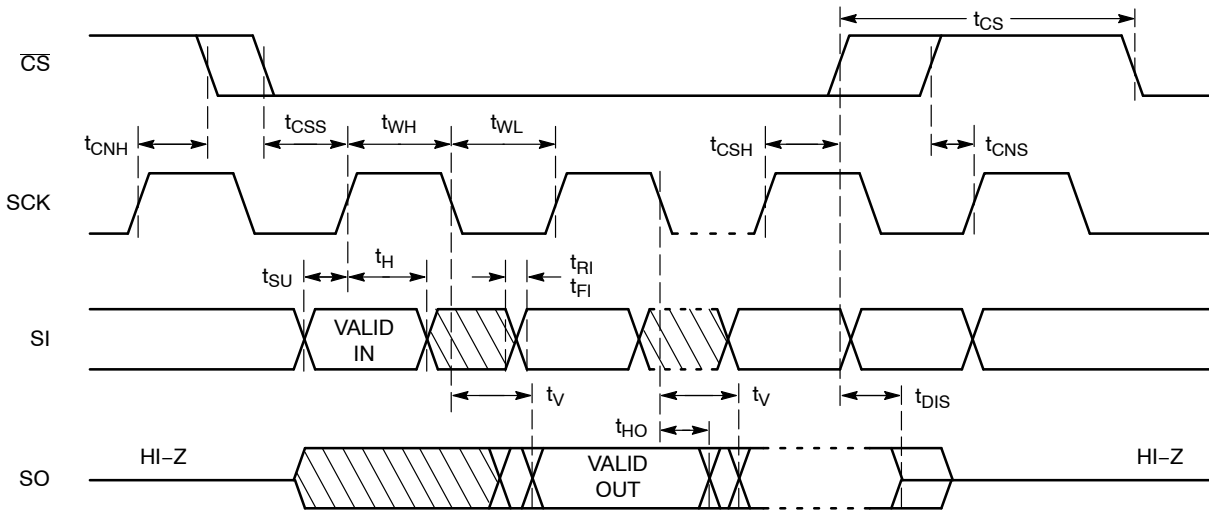

**Figure 2. Synchronous Data Timing**

**Status Register**

The Status Register, as shown in Table 8, contains a number of status and control bits.

The RDY (Ready) bit indicates whether the device is busy with a write operation. This bit is automatically set to 1 during an internal write cycle, and reset to 0 when the device is ready to accept commands. For the host, this bit is read only.

The WEL (Write Enable Latch) bit is set/reset by the WREN/WRDI commands. When set to 1, the device is in a

Write Enable state and when set to 0, the device is in a Write Disable state.

The BP0 and BP1 (Block Protect) bits determine which blocks are currently write protected. They are set by the user with the WRSR command and are non-volatile. The user is allowed to protect a quarter, one half or the entire memory, by setting these bits according to Table 9. The protected blocks then become read-only.

# NV25080MUW, NV25160MUW

**Table 8. STATUS REGISTER**

7	6	5	4	3	2	1	0
WPEN	0	0	0	BP1	BP0	WEL	RDY

**Table 9. BLOCK PROTECTION BITS**

Status Register Bits		Array Address Protected	Protection
BP1	BP0		
0	0	None	No Protection
0	1	25080: 0300–03FF 25160: 0600–07FF	Quarter Array Protection
1	0	25080: 0200–03FF 25160: 0400–07FF	Half Array Protection
1	1	25080: 0000–03FF 25160: 0000–07FF	Full Array Protection

**Table 10. WRITE PROTECT CONDITIONS**

WPEN	WP	WEL	Protected Blocks	Unprotected Blocks	Status Register
0	X	0	Protected	Protected	Protected
0	X	1	Protected	Writable	Writable
1	Low	0	Protected	Protected	Protected
1	Low	1	Protected	Writable	Protected
X	High	0	Protected	Protected	Protected
X	High	1	Protected	Writable	Writable

WRITE OPERATIONS

The NV25080/160 device powers up into a write disable state. The device contains a Write Enable Latch (WEL) which must be set before attempting to write to the memory array or to the status register. In addition, the address of the memory location(s) to be written must be outside the protected area, as defined by BP0 and BP1 bits from the status register.

instruction to the NV25080/160. Care must be taken to take the  $\overline{CS}$  input high after the WREN instruction, as otherwise the Write Enable Latch will not be properly set. WREN timing is illustrated in Figure 3. The WREN instruction must be sent prior to any WRITE or WRSR instruction.

The internal write enable latch is reset by sending the WRDI instruction as shown in Figure 4. Disabling write operations by resetting the WEL bit, will protect the device against inadvertent writes.

Write Enable and Write Disable

The internal Write Enable Latch and the corresponding Status Register WEL bit are set by sending the WREN

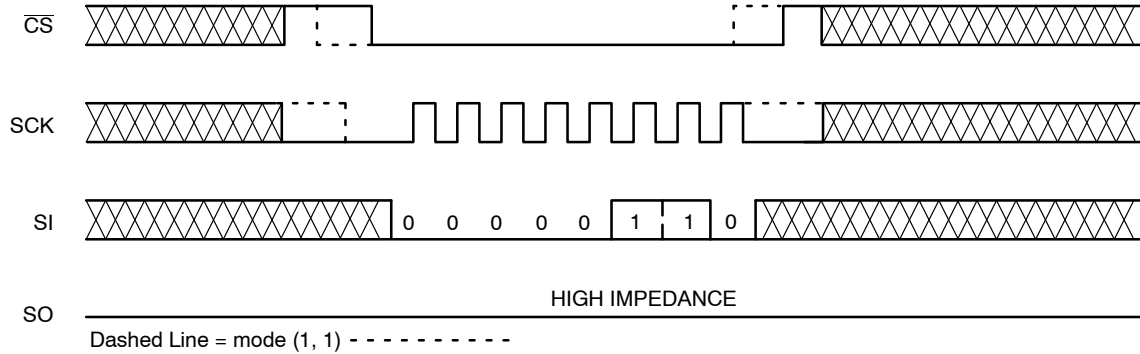

Figure 3. WREN Timing

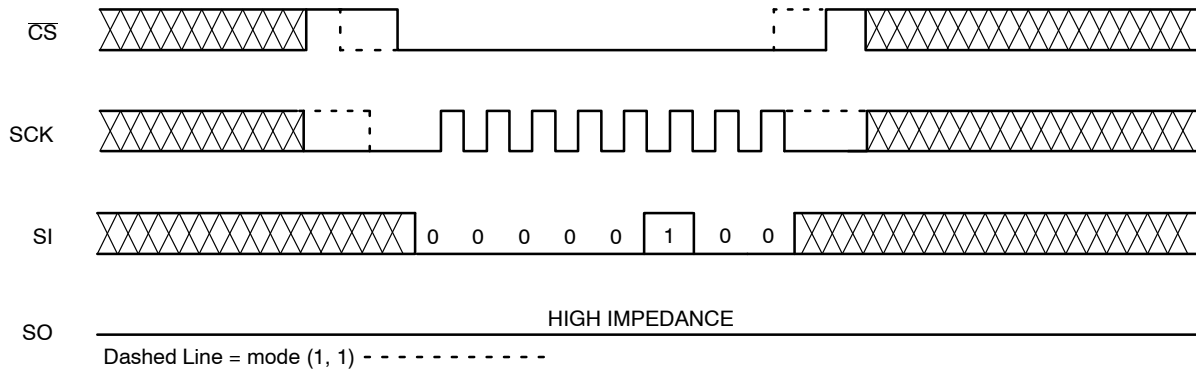

Figure 4. WRDI Timing

# NV25080MUW, NV25160MUW

## Byte Write

Once the WEL bit is set, the user may execute a write sequence, by sending a WRITE instruction, a 16-bit address and data as shown in Figure 5. Only 10 significant address bits are used by the NV25080 and 11 by the NV25160. The rest are don't care bits, as shown in Table 11. Internal programming will start after the low to high  $\overline{CS}$  transition. During an internal write cycle, all commands, except for RDSR (Read Status Register) will be ignored. The  $\overline{RDY}$  bit will indicate if the internal write cycle is in progress ( $\overline{RDY}$  high), or the device is ready to accept commands ( $\overline{RDY}$  low).

## Page Write

After sending the first data byte to the NV25080/160, the host may continue sending data, up to a total of 32 bytes, according to timing shown in Figure 6. After each data byte, the lower order address bits are automatically incremented, while the higher order address bits (page address) remain unchanged. If during this process the end of page is exceeded, then loading will "roll over" to the first byte in the page, thus possibly overwriting previously loaded data. Following completion of the write cycle, the NV25080/160 is automatically returned to the write disable state.

**Table 11. BYTE ADDRESS**

Device	Address Significant Bits	Address Don't Care Bits	# Address Clock Pulse
NV25080	A9 – A0	A15 – A10	16
NV25160	A10 – A0	A15 – A11	16

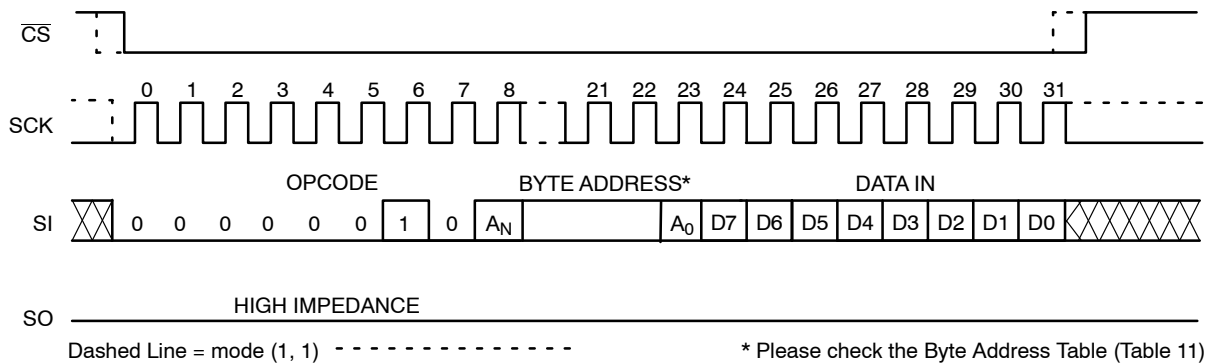

**Figure 5. Byte WRITE Timing**

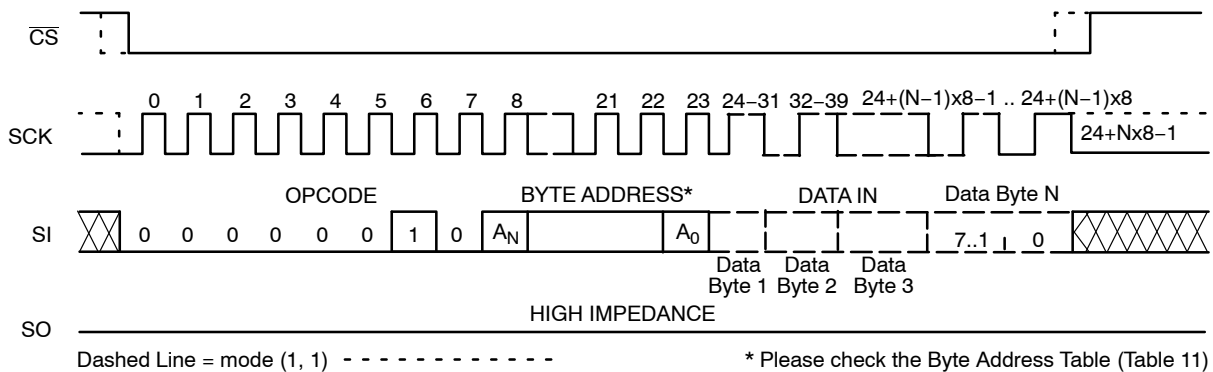

**Figure 6. Page WRITE Timing**

**Write Status Register**

The Status Register is written by sending a WRSR instruction according to timing shown in Figure 7. Only bits 2, 3 and 7 can be written using the WRSR command.

**Write Protection**

The Write Protect ( $\overline{WP}$ ) pin can be used to protect the Block Protect bits BP0 and BP1 against being inadvertently altered. When  $\overline{WP}$  is low and the WPEN bit is set to "1", write operations to the Status Register are inhibited.  $\overline{WP}$  going low while  $\overline{CS}$  is still low will interrupt a write to the status register. If the internal write cycle has already been initiated,  $\overline{WP}$  going low will have no effect on any write operation to the Status Register. The  $\overline{WP}$  pin function is blocked when the WPEN bit is set to "0". The  $\overline{WP}$  input timing is shown in Figure 8.

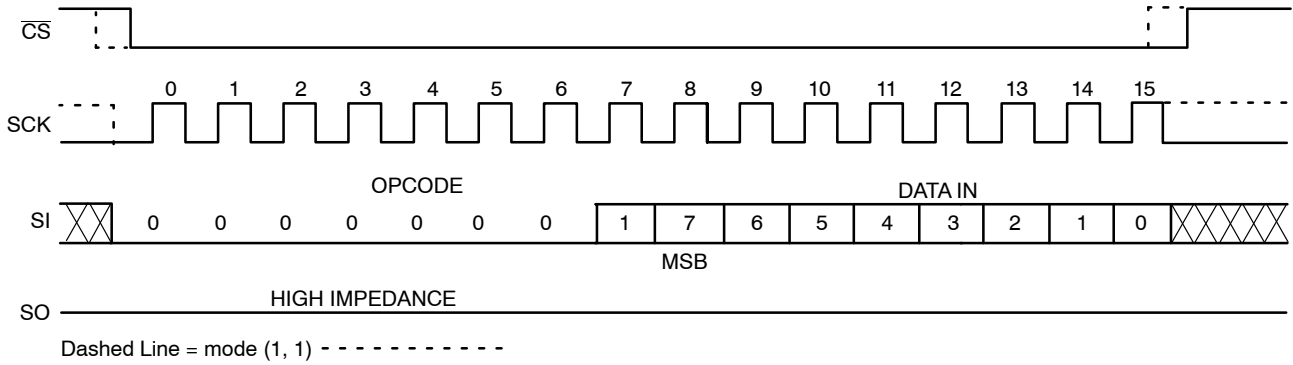

Figure 7. WRSR Timing

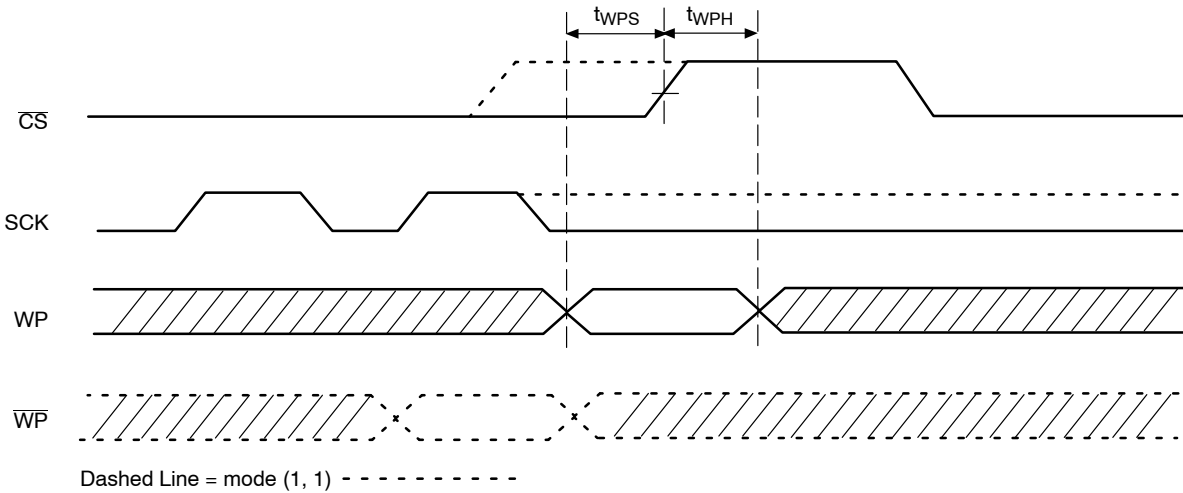

Figure 8. WP Timing

READ OPERATIONS

Read from Memory Array

To read from memory, the host sends a READ instruction followed by a 16-bit address (see Table 11 for the number of significant address bits).

After receiving the last address bit, the NV25080/160 will respond by shifting out data on the SO pin (as shown in Figure 9). Sequentially stored data can be read out by simply continuing to run the clock. The internal address pointer is automatically incremented to the next higher address as data is shifted out. After reaching the highest memory address, the address counter “rolls over” to the lowest memory address, and the read cycle can be continued indefinitely. The read operation is terminated by taking CS high.

Read Status Register

To read the status register, the host simply sends a RDSR command. After receiving the last bit of the command, the NV25080/160 will shift out the contents of the status register on the SO pin (Figure 10). The status register may be read at any time, including during an internal write cycle. While the internal write cycle is in progress, the RDSR command will output the full content of the status register. For easy detection of the internal write cycle completion, both during writing to the memory array and to the status register, we recommend sampling the RDY bit only through the polling routine. After detecting the RDY bit “0”, the next RDSR instruction will always output the expected content of the status register.

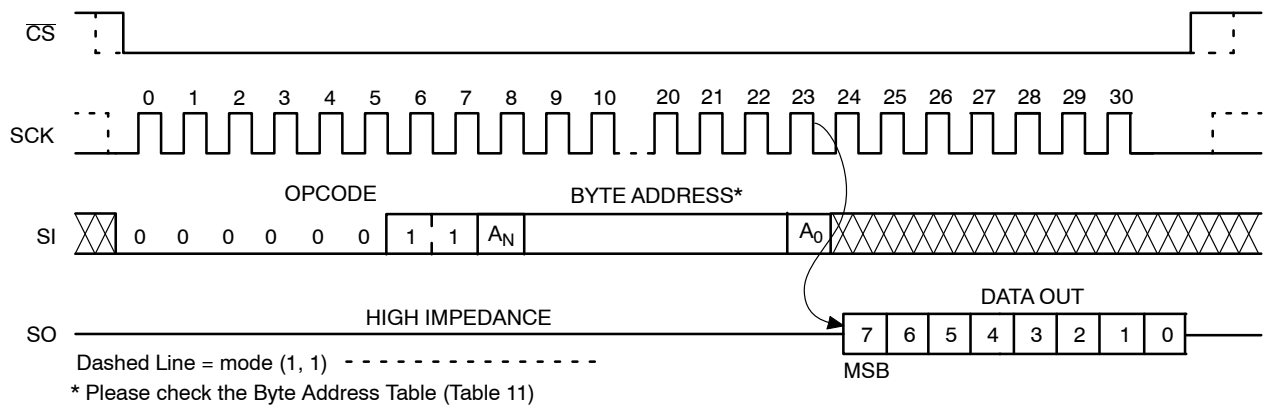

Figure 9. READ Timing

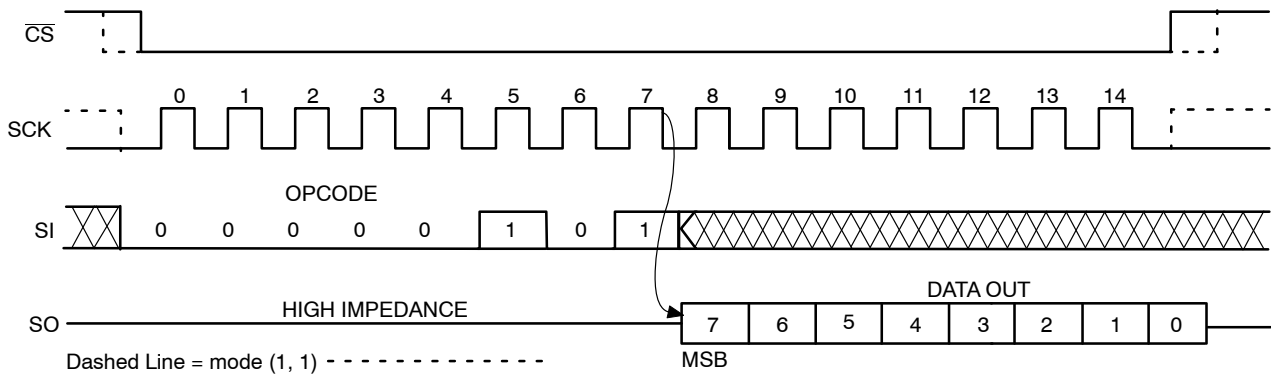

Figure 10. RDSR Timing

**Hold Operation**

The  $\overline{\text{HOLD}}$  input can be used to pause communication between host and NV25080/160. To pause,  $\overline{\text{HOLD}}$  must be taken low while SCK is low (Figure 11). During the hold condition the device must remain selected ( $\overline{\text{CS}}$  low). During the pause, the data output pin (SO) is tri-stated (high impedance) and SI transitions are ignored. To resume communication,  $\overline{\text{HOLD}}$  must be taken high while SCK is low.

**DESIGN CONSIDERATIONS**

The NV25080/160 devices incorporate Power-On Reset (POR) circuitry which protects the internal logic against powering up in the wrong state. The device will power up into Standby mode after  $V_{CC}$  exceeds the POR trigger level and will power down into Reset mode when  $V_{CC}$  drops

below the POR trigger level. This bi-directional POR behavior protects the device against ‘brown-out’ failure following a temporary loss of power.

The NV25080/160 device powers up in a write disable state and in a low power standby mode. A WREN instruction must be issued prior to any writes to the device.

After power up, the  $\overline{\text{CS}}$  pin must be brought low to enter a ready state and receive an instruction. After a successful byte/page write or status register write, the device goes into a write disable mode. The  $\overline{\text{CS}}$  input must be set high after the proper number of clock cycles to start the internal write cycle. Access to the memory array during an internal write cycle is ignored and programming is continued. Any invalid op-code will be ignored and the serial output pin (SO) will remain in the high impedance state.

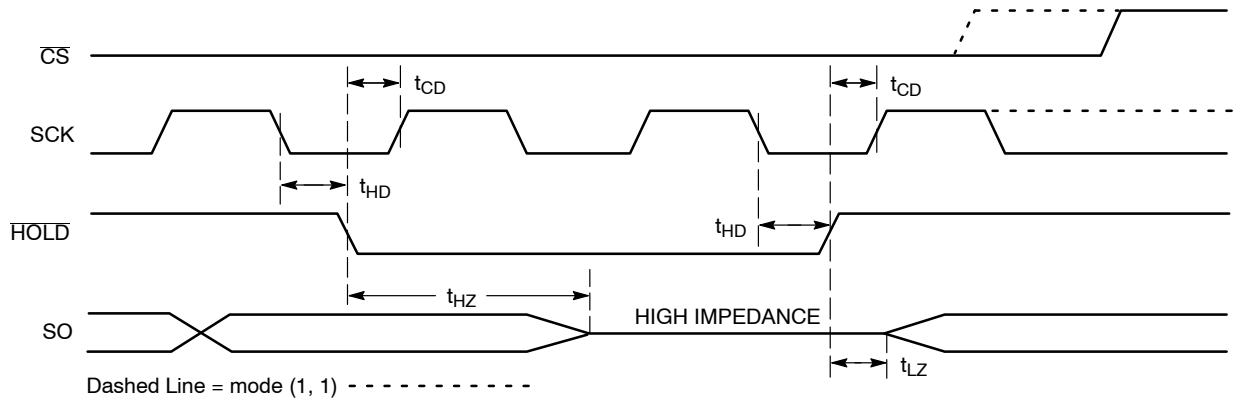

Figure 11.  $\overline{\text{HOLD}}$  Timing

## NV25080MUW, NV25160MUW

### ORDERING INFORMATION (Notes 8 and 9)

Device Order Number	Specific Device Marking	Temperature Range	Package Type	Shipping <sup>†</sup>
NV25080MUW2VTAG	D3	-40°C to +125°C	UDFN8 (2x2) (Wettable Flank) (Pb-Free)	3000 / Tape & Reel
NV25080MUW3VTBG	S3W	-40°C to +125°C	UDFN8 (2x3) (Wettable Flank) (Pb-Free)	3000 / Tape & Reel
NV25160MUW3VTBG	S4W	-40°C to +125°C	UDFN8 (2x3) (Wettable Flank) (Pb-Free)	3000 / Tape & Reel

<sup>†</sup> For information on tape and reel specifications, including part orientation and tape sizes, please refer to our Tape and Reel Packaging Specifications Brochure, BRD8011/D.

8. All packages are RoHS-compliant (Pb-Free, Halogen-free).

9. For additional package and temperature options, please contact your nearest **onsemi** Sales office.



SCALE 2:1

UDFN8, 2x2  
CASE 517AW  
ISSUE A

DATE 13 NOV 2015

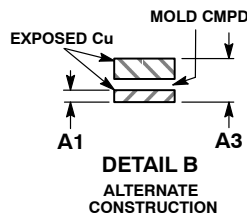
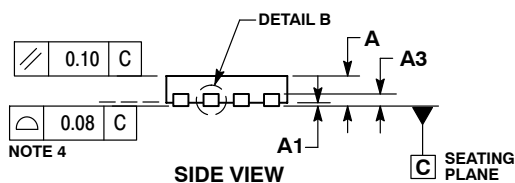
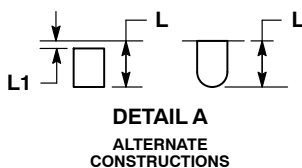
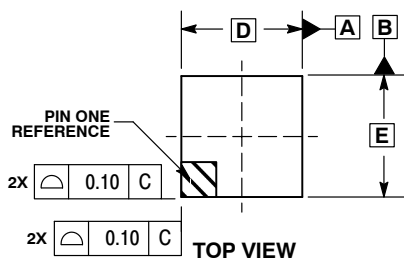

- NOTES:
1. DIMENSIONING AND TOLERANCING PER ASME Y14.5M, 1994.
  2. CONTROLLING DIMENSION: MILLIMETERS.
  3. DIMENSION b APPLIES TO PLATED TERMINALS AND IS MEASURED BETWEEN 0.15 AND 0.30 MM FROM THE TERMINAL TIP.
  4. COPLANARITY APPLIES TO THE EXPOSED PAD AS WELL AS THE TERMINALS.
  5. FOR DEVICE OPN CONTAINING W OPTION, DETAIL B ALTERNATE CONSTRUCTION IS NOT APPLICABLE.

DIM	MILLIMETERS	
	MIN	MAX
A	0.45	0.55
A1	0.00	0.05
A3	0.13 REF	
b	0.18	0.30
D	2.00 BSC	
D2	1.50	1.70
E	2.00 BSC	
E2	0.80	1.00
e	0.50 BSC	
L	0.20	0.45
L1	---	0.15

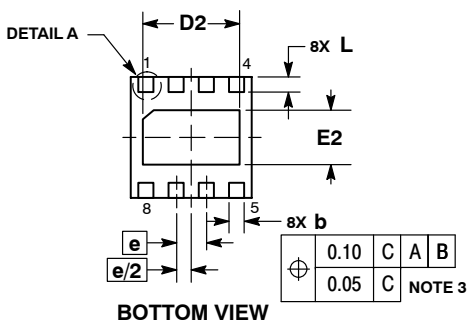

GENERIC MARKING DIAGRAM\*

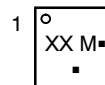

- XX = Specific Device Code
- M = Date Code
- = Pb-Free Package

(Note: Microdot may be in either location)  
\*This information is generic. Please refer to device data sheet for actual part marking. Pb-Free indicator, "G" or microdot "▪", may or may not be present.

RECOMMENDED SOLDERING FOOTPRINT\*

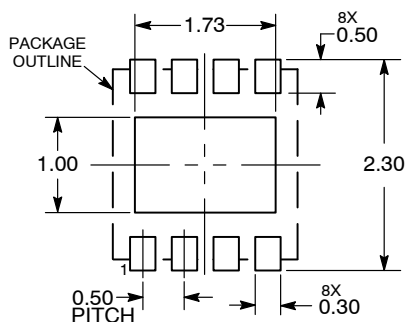

\*For additional information on our Pb-Free strategy and soldering details, please download the onsemi Soldering and Mounting Techniques Reference Manual, SOLDERRM/D.

DOCUMENT NUMBER:	98AON34462E	Electronic versions are uncontrolled except when accessed directly from the Document Repository. Printed versions are uncontrolled except when stamped "CONTROLLED COPY" in red.
DESCRIPTION:	UDFN8, 2X2	PAGE 1 OF 1

onsemi and ONSEMI are trademarks of Semiconductor Components Industries, LLC dba onsemi or its subsidiaries in the United States and/or other countries. onsemi reserves the right to make changes without further notice to any products herein. onsemi makes no warranty, representation or guarantee regarding the suitability of its products for any particular purpose, nor does onsemi assume any liability arising out of the application or use of any product or circuit, and specifically disclaims any and all liability, including without limitation special, consequential or incidental damages. onsemi does not convey any license under its patent rights nor the rights of others.



SCALE 2:1

UDFN8 2x3, 0.5P  
CASE 517DH  
ISSUE A

DATE 10 DEC 2020

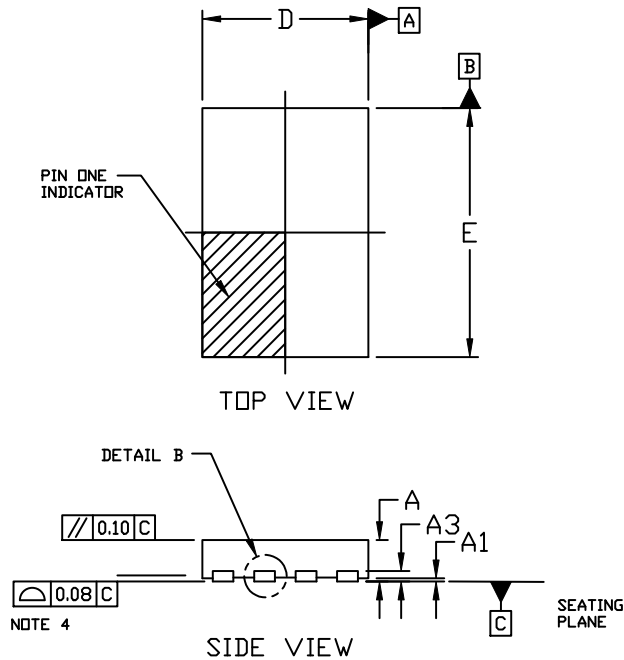

- NOTES:
1. DIMENSIONING AND TOLERANCING PER ASME Y14.5M,1994.
  2. CONTROLLING DIMENSION: MILLIMETERS
  3. DIMENSION b APPLIES TO PLATED TERMINAL AND IS MEASURED BETWEEN 0.15 AND 0.25MM FROM THE TERMINAL TIP.
  4. COPLANARITY APPLIES TO THE EXPOSED PAD AS WELL AS THE TERMINALS.

DIM	MILLIMETERS		
	MIN.	NDM.	MAX.
A	0.45	0.50	0.55
A1	0.00	---	0.05
A3	0.13 REF		
b	0.20	0.25	0.30
D	1.90	2.00	2.10
D2	1.30	1.40	1.50
E	2.90	3.00	3.10
E2	1.30	1.40	1.50
e	0.50 BSC		
K	0.40 REF		
L	0.30	0.40	0.50

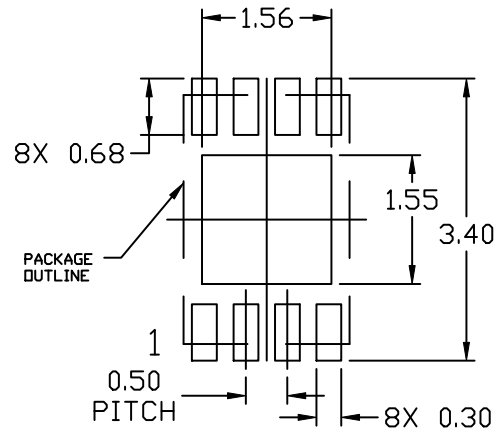
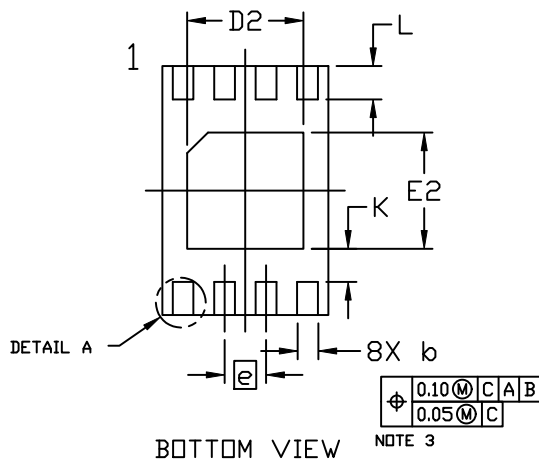

RECOMMENDED MOUNTING FOOTPRINT\*  
\* For additional information on our Pb-Free strategy and soldering details, please download the DN Semiconductor Soldering and Mounting Techniques Reference Manual, SOLDERRM/D.

GENERIC MARKING DIAGRAM\*

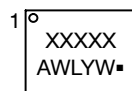

- XXXXX = Specific Device Code
- A = Assembly Location
- WL = Wafer Lot
- Y = Year
- W = Work Week
- = Pb-Free Package

\*This information is generic. Please refer to device data sheet for actual part marking. Pb-Free indicator, "G" or microdot "▪", may or may not be present. Some products may not follow the Generic Marking.

DOCUMENT NUMBER:	98AON06579G	Electronic versions are uncontrolled except when accessed directly from the Document Repository. Printed versions are uncontrolled except when stamped "CONTROLLED COPY" in red.
DESCRIPTION:	UDFN8 2X3, 0.5P	PAGE 1 OF 1

onsemi and ONSEMI are trademarks of Semiconductor Components Industries, LLC dba onsemi or its subsidiaries in the United States and/or other countries. onsemi reserves the right to make changes without further notice to any products herein. onsemi makes no warranty, representation or guarantee regarding the suitability of its products for any particular purpose, nor does onsemi assume any liability arising out of the application or use of any product or circuit, and specifically disclaims any and all liability, including without limitation special, consequential or incidental damages. onsemi does not convey any license under its patent rights nor the rights of others.

**onsemi**, **Onsemi**, and other names, marks, and brands are registered and/or common law trademarks of Semiconductor Components Industries, LLC dba "**onsemi**" or its affiliates and/or subsidiaries in the United States and/or other countries. **onsemi** owns the rights to a number of patents, trademarks, copyrights, trade secrets, and other intellectual property. A listing of **onsemi**'s product/patent coverage may be accessed at [www.onsemi.com/site/pdf/Patent-Marking.pdf](http://www.onsemi.com/site/pdf/Patent-Marking.pdf). **onsemi** reserves the right to make changes at any time to any products or information herein, without notice. The information herein is provided "as-is" and **onsemi** makes no warranty, representation or guarantee regarding the accuracy of the information, product features, availability, functionality, or suitability of its products for any particular purpose, nor does **onsemi** assume any liability arising out of the application or use of any product or circuit, and specifically disclaims any and all liability, including without limitation special, consequential or incidental damages. Buyer is responsible for its products and applications using **onsemi** products, including compliance with all laws, regulations and safety requirements or standards, regardless of any support or applications information provided by **onsemi**. "Typical" parameters which may be provided in **onsemi** data sheets and/or specifications can and do vary in different applications and actual performance may vary over time. All operating parameters, including "Typicals" must be validated for each customer application by customer's technical experts. **onsemi** does not convey any license under any of its intellectual property rights nor the rights of others. **onsemi** products are not designed, intended, or authorized for use as a critical component in life support systems or any FDA Class 3 medical devices or medical devices with a same or similar classification in a foreign jurisdiction or any devices intended for implantation in the human body. Should Buyer purchase or use **onsemi** products for any such unintended or unauthorized application, Buyer shall indemnify and hold **onsemi** and its officers, employees, subsidiaries, affiliates, and distributors harmless against all claims, costs, damages, and expenses, and reasonable attorney fees arising out of, directly or indirectly, any claim of personal injury or death associated with such unintended or unauthorized use, even if such claim alleges that **onsemi** was negligent regarding the design or manufacture of the part. **onsemi** is an Equal Opportunity/Affirmative Action Employer. This literature is subject to all applicable copyright laws and is not for resale in any manner.

## ADDITIONAL INFORMATION

### TECHNICAL PUBLICATIONS:

Technical Library: [www.onsemi.com/design/resources/technical-documentation](http://www.onsemi.com/design/resources/technical-documentation)  
onsemi Website: [www.onsemi.com](http://www.onsemi.com)

### ONLINE SUPPORT: [www.onsemi.com/support](http://www.onsemi.com/support)

For additional information, please contact your local Sales Representative at [www.onsemi.com/support/sales](http://www.onsemi.com/support/sales)

