

# Silicon Carbide (SiC) MOSFET - EliteSiC, 23 mohm, 650 V, M3S, TOLL NTBL023N065M3S

## Features

- Typical  $R_{DS(on)} = 23 \text{ m}\Omega @ V_{GS} = 18 \text{ V}$
- Ultra Low Gate Charge ( $Q_{G(tot)} = 69 \text{ nC}$ )
- High Speed Switching with Low Capacitance ( $C_{oss} = 152 \text{ pF}$ )
- 100% Avalanche Tested
- This Device is Halide Free and RoHS Compliant with Exemption 7a, Pb-Free 2LI (on second level interconnection)

## Applications

- Switching Mode Power Supplies (SMPS)
- Solar Inverters
- Uninterruptable Power Supplies (UPS)
- Energy Storage
- Infrastructure

## MAXIMUM RATINGS ( $T_J = 25 \text{ }^\circ\text{C}$ unless otherwise noted)

Parameter	Symbol	Value	Unit	
Drain-to-Source Voltage	$V_{DSS}$	650	V	
Gate-to-Source Static Voltage	$V_{GS}$	-10/+22.6	V	
Gate-to-Source Transient Voltage	$V_{GS}$	-11/+25	V	
Continuous Drain Current	$T_C = 25 \text{ }^\circ\text{C}$	$I_D$	77	A
Power Dissipation	$P_D$	312	W	
Continuous Drain Current	$T_C = 100 \text{ }^\circ\text{C}$	$I_D$	54	A
Power Dissipation	$P_D$	156	W	
Pulsed Drain Current (Note 1)	$T_C = 25 \text{ }^\circ\text{C}$ $t_p = 100 \text{ }\mu\text{s}$	$I_{DM}$	280	A
Continuous Source-Drain Current (Body Diode)	$T_C = 25 \text{ }^\circ\text{C}$ , $V_{GS} = -3 \text{ V}$	$I_S$	46	A
	$T_C = 100 \text{ }^\circ\text{C}$ , $V_{GS} = -3 \text{ V}$		27	
Pulsed Source-Drain Current (Body Diode) (Note 1)	$T_C = 25 \text{ }^\circ\text{C}$ , $V_{GS} = -3 \text{ V}$ , $t_p = 100 \text{ }\mu\text{s}$	$I_{SM}$	274	A
Single Pulse Avalanche Energy ( $I_{LPK} = 19.6 \text{ A}$ , $L = 1 \text{ mH}$ ) (Note 2)	$E_{AS}$	192	mJ	
Operating Junction and Storage Temperature Range	$T_J, T_{stg}$	-55 to +175	$^\circ\text{C}$	
Lead Temperature for Soldering Purposes (1/8" from case for 10 s)	$T_L$	260	$^\circ\text{C}$	

Stresses exceeding those listed in the Maximum Ratings table may damage the device. If any of these limits are exceeded, device functionality should not be assumed, damage may occur and reliability may be affected.

1. Repetitive rating, limited by max junction temperature.
2.  $E_{AS}$  of 192 mJ is based on starting  $T_J = 25 \text{ }^\circ\text{C}$ ;  $L = 1 \text{ mH}$ ,  $I_{AS} = 19.6 \text{ A}$ ,  $V_{DD} = 100 \text{ V}$ ,  $V_{GS} = 18 \text{ V}$ .

$V_{DSS}$	$R_{DS(ON)}$ TYP	$I_D$ MAX
650 V	23 m $\Omega$ @ 18 V	77 A

## N-CHANNEL MOSFET

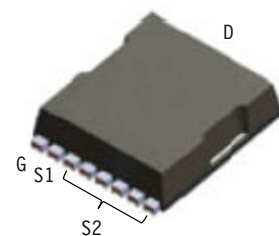
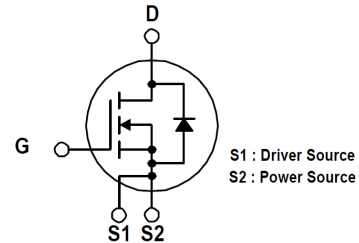

H-PSOF8L  
CASE 100DC

## MARKING DIAGRAM

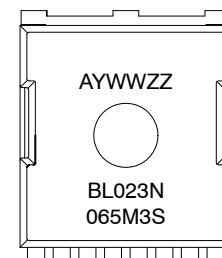

- A = Assembly Location
- Y = Year
- WW = Work Week
- ZZ = Assembly Lot Code
- BL023N065M3S = Specific Device Code

## ORDERING INFORMATION

See detailed ordering and shipping information on page 7 of this data sheet.

# NTBL023N065M3S

## THERMAL CHARACTERISTICS

Parameter	Symbol	Value	Unit
Thermal Resistance, Junction-to-Case (Note 3)	$R_{\theta JC}$	0.48	$^{\circ}C/W$
Thermal Resistance, Junction-to-Ambient (Note 3)	$R_{\theta JA}$	43	$^{\circ}C/W$

3. The entire application environment impacts the thermal resistance values shown, they are not constants and are only valid for the particular conditions noted.

## RECOMMENDED OPERATING CONDITIONS

Parameter	Symbol	Value	Unit
Operation Values of Gate-to-Source Voltage	$V_{GSop}$	-5...-3/+18	V

Functional operation above the stresses listed in the Recommended Operating Ranges is not implied. Extended exposure to stresses beyond the Recommended Operating Ranges limits may affect device reliability.

## ELECTRICAL CHARACTERISTICS ( $T_J = 25^{\circ}C$ unless otherwise stated)

Parameter	Symbol	Test Condition	Min	Typ	Max	Unit
-----------	--------	----------------	-----	-----	-----	------

### OFF CHARACTERISTICS

Drain-to-Source Breakdown Voltage	$V_{(BR)DSS}$	$V_{GS} = 0 V, I_D = 1 mA$	650			V
Drain-to-Source Breakdown Voltage Temperature Coefficient	$\Delta V_{(BR)DSS} / \Delta T_J$	$I_D = 1 mA$ , Referenced to $25^{\circ}C$		89		$mV/^{\circ}C$
Zero Gate Voltage Drain Current	$I_{DSS}$	$V_{DS} = 650 V, T_J = 25^{\circ}C$			10	$\mu A$
		$V_{DS} = 650 V, T_J = 175^{\circ}C$ (Note 5)			500	$\mu A$
Gate-to-Source Leakage Current	$I_{GSS}$	$V_{GS} = -10 V, V_{DS} = 0 V$	-1			$\mu A$
		$V_{GS} = +22.6 V, V_{DS} = 0 V$			1	

### ON CHARACTERISTICS

Drain-to-Source On Resistance	$R_{DS(on)}$	$V_{GS} = 18 V, I_D = 20 A, T_J = 25^{\circ}C$		23	32.6	m $\Omega$
		$V_{GS} = 18 V, I_D = 20 A, T_J = 175^{\circ}C$		34		
		$V_{GS} = 15 V, I_D = 20 A, T_J = 25^{\circ}C$		29		
		$V_{GS} = 15 V, I_D = 20 A, T_J = 175^{\circ}C$		37		
Gate Threshold Voltage	$V_{GS(TH)}$	$V_{GS} = V_{DS}, I_D = 10 mA$	2	2.8	4	V
Forward Transconductance	$g_{FS}$	$V_{DS} = 10 V, I_D = 20 A$		14		S

### CHARGES, CAPACITANCES & GATE RESISTANCE

Input Capacitance	$C_{ISS}$	$V_{GS} = 0 V, f = 1 MHz, V_{DS} = 400 V$ (Note 5)		1950		pF
Output Capacitance	$C_{OSS}$			152		
Reverse Transfer Capacitance	$C_{RSS}$			13		
Total Gate Charge	$Q_{G(TOT)}$	$V_{GS} = -3/18 V, V_{DD} = 400 V, I_D = 20 A$ (Note 5)		69		nC
Gate-to-Source Charge	$Q_{GS}$			19		
Gate-to-Drain Charge	$Q_{GD}$			18		
Gate-Resistance	$R_G$	$f = 1 MHz$		4.0		$\Omega$

### SWITCHING CHARACTERISTICS

Turn-On Delay Time	$t_{d(ON)}$	$V_{GS} = -3/18 V, V_{DD} = 400 V, I_D = 20 A, R_G = 4.7 \Omega, T_J = 25^{\circ}C$ , (Notes 4, 5)		11		ns
Turn-Off Delay Time	$t_{d(OFF)}$			35		
Rise Time	$t_r$			15		
Fall Time	$t_f$			9.6		
Turn-On Switching Loss	$E_{ON}$			51		$\mu J$
Turn-Off Switching Loss	$E_{OFF}$			29		
Total Switching Loss	$E_{TOT}$			80		

# NTBL023N065M3S

## ELECTRICAL CHARACTERISTICS (T<sub>J</sub> = 25 °C unless otherwise stated)

Parameter	Symbol	Test Condition	Min	Typ	Max	Unit
<b>SWITCHING CHARACTERISTICS</b>						
Turn-On Delay Time	t <sub>d(ON)</sub>	V <sub>GS</sub> = -3/18 V, V <sub>DS</sub> = 400 V, I <sub>D</sub> = 20 A, R <sub>G</sub> = 4.7 Ω, T <sub>J</sub> = 175 °C, (Notes 4, 5)		9.6		ns
Turn-Off Delay Time	t <sub>d(OFF)</sub>			41		
Rise Time	t <sub>r</sub>			14		
Fall Time	t <sub>f</sub>			12		
Turn-On Switching Loss	E <sub>ON</sub>			51		μJ
Turn-Off Switching Loss	E <sub>OFF</sub>			45		
Total Switching Loss	E <sub>TOT</sub>			96		

## SOURCE-TO-DRAIN DIODE CHARACTERISTICS

Forward Diode Voltage	V <sub>SD</sub>	V <sub>GS</sub> = -3 V, I <sub>SD</sub> = 20 A, T <sub>J</sub> = 25 °C		4.5	6.0	V
		V <sub>GS</sub> = -3 V, I <sub>SD</sub> = 20 A, T <sub>J</sub> = 175 °C		4.2		
Reverse Recovery Time	t <sub>RR</sub>	V <sub>GS</sub> = -3 V, I <sub>S</sub> = 20 A, di/dt = 1000 A/μs, V <sub>DS</sub> = 400 V (Note 5)		19		ns
Charge Time	t <sub>a</sub>			11		
Discharge Time	t <sub>b</sub>			8		
Reverse Recovery Charge	Q <sub>RR</sub>			97		nC
Reverse Recovery Energy	E <sub>REC</sub>			8.7		μJ
Peak Reverse Recovery Current	I <sub>RRM</sub>			11		A

Product parametric performance is indicated in the Electrical Characteristics for the listed test conditions, unless otherwise noted. Product performance may not be indicated by the Electrical Characteristics if operated under different conditions.

4. E<sub>ON</sub>/E<sub>OFF</sub> result is with body diode.

5. Defined by design, not subject to production test.

TYPICAL CHARACTERISTICS

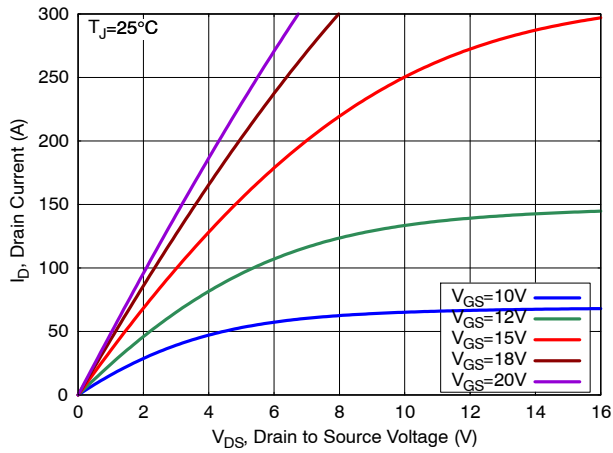

Figure 1. On-Region Characteristics

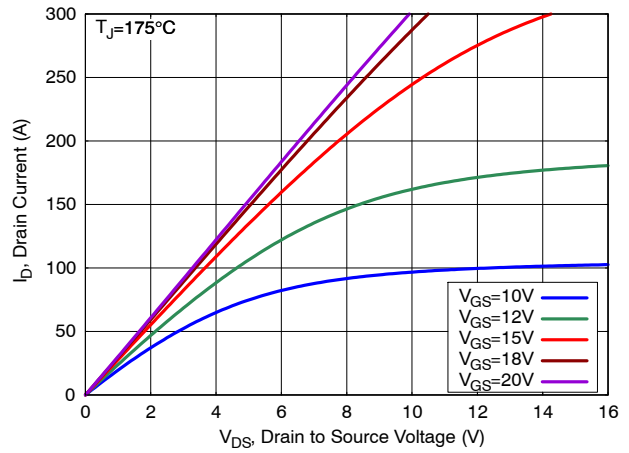

Figure 2. Output Characteristics

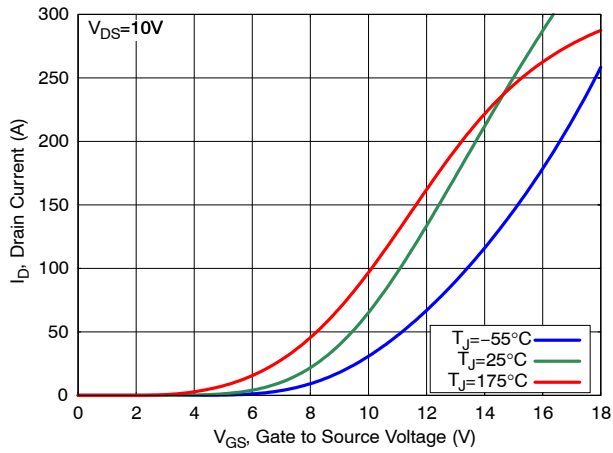

Figure 3. Transfer Characteristics

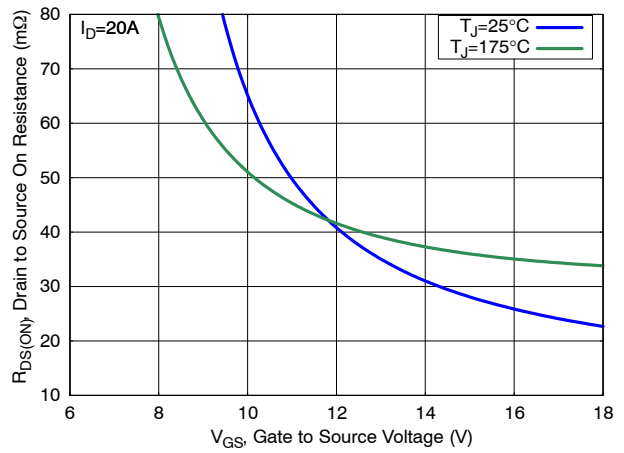

Figure 4. On-Resistance vs. Gate Voltage

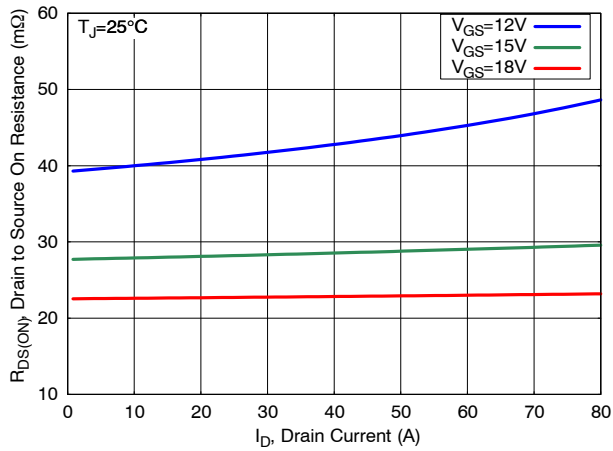

Figure 5. On-Resistance vs. Drain Current

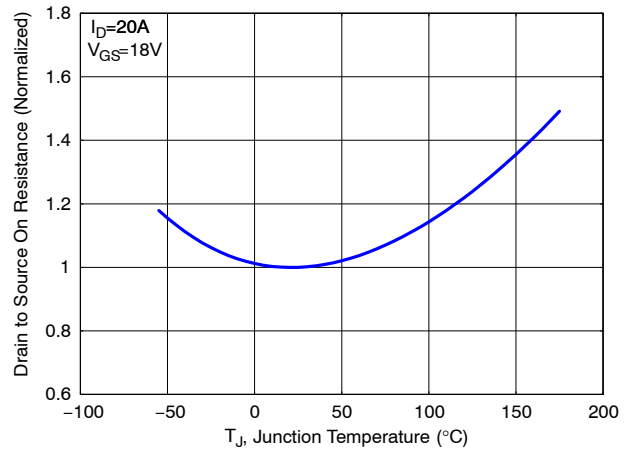

Figure 6. On-Resistance vs. Junction Temperature

TYPICAL CHARACTERISTICS

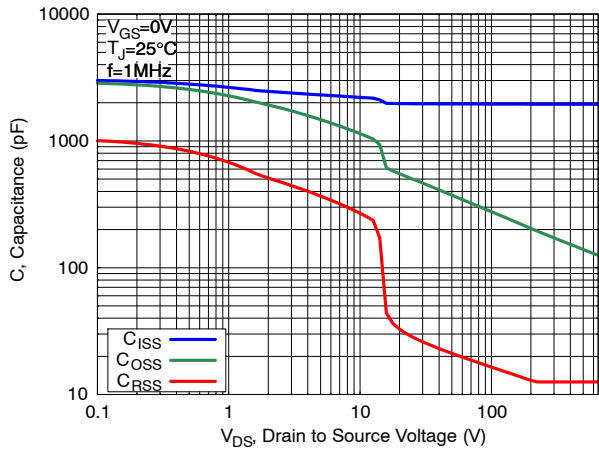

Figure 7. Capacitance Characteristics

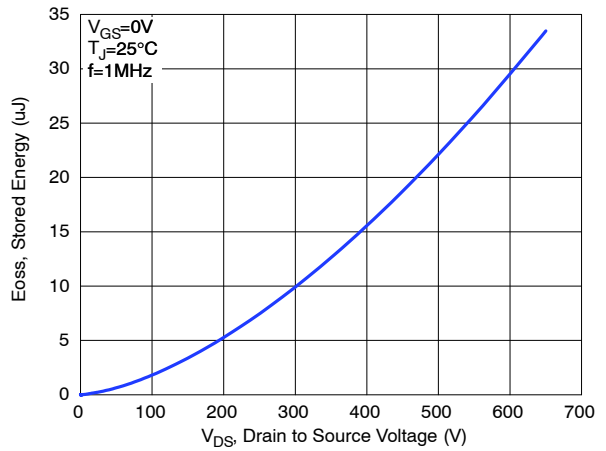

Figure 8. Stored Energy vs. Drain-to-Source Voltage

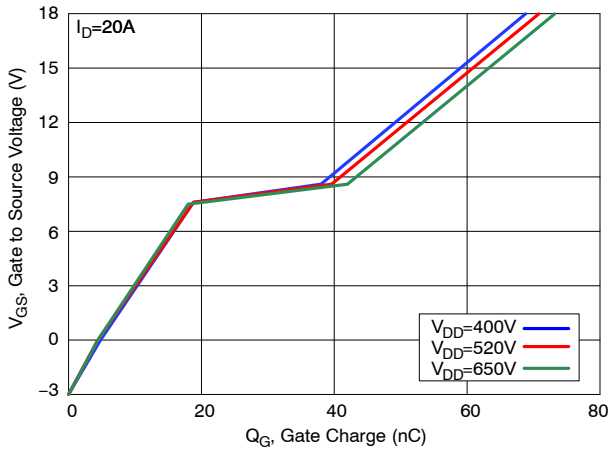

Figure 9. Gate Charge Characteristics

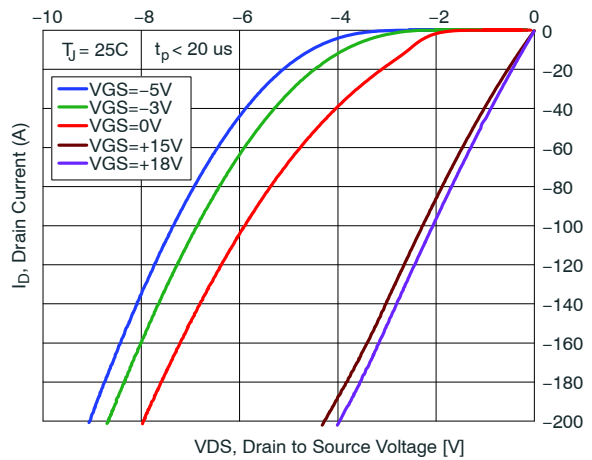

Figure 10. Reverse Conduction Characteristics

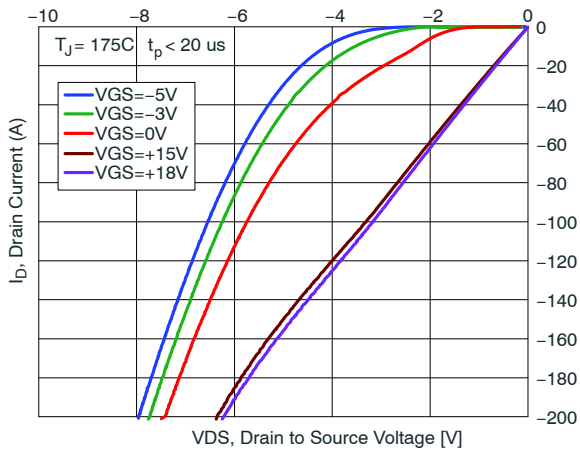

Figure 11. Reverse Conduction Characteristics

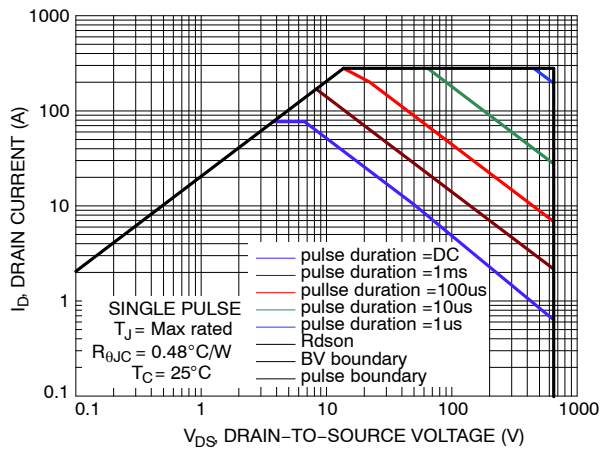

Figure 12. Safe Operating Area

TYPICAL CHARACTERISTICS

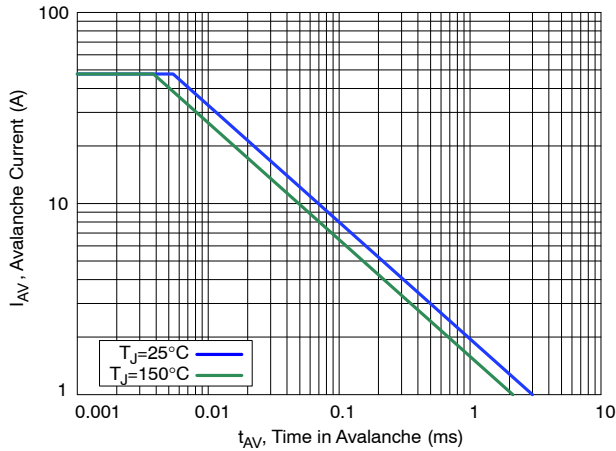

Figure 13. Avalanche Current vs. Pulse Time (UIS)

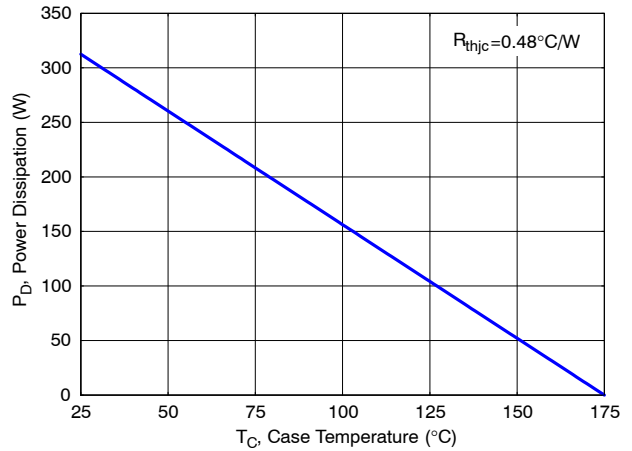

Figure 14. Maximum Power Dissipation vs. Case Temperature

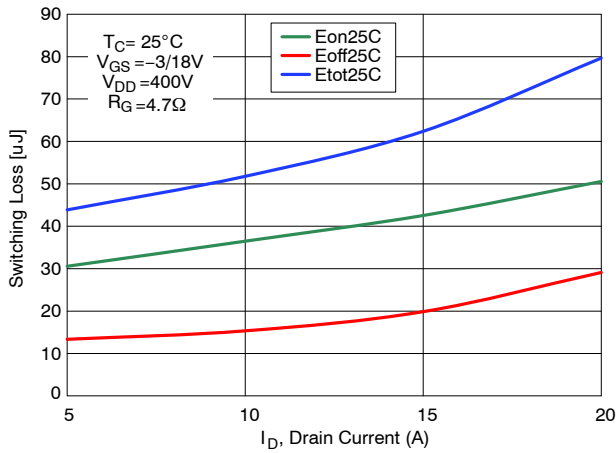

Figure 15. Switching Loss vs. Collector Current

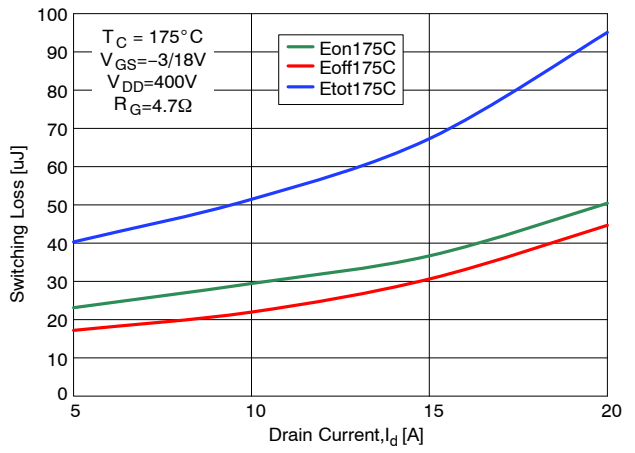

Figure 16. Switching Loss vs. Drain Current

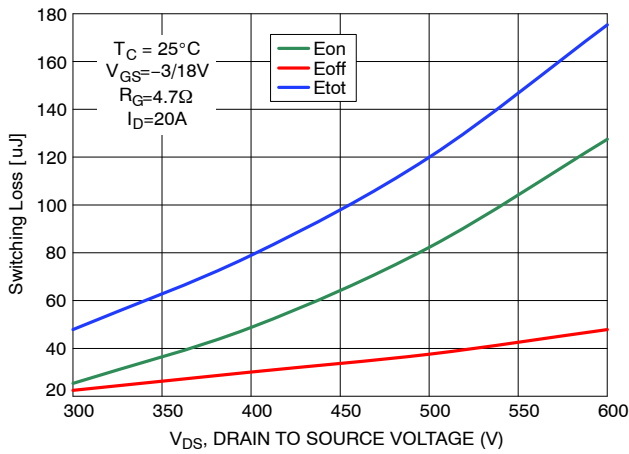

Figure 17. Switching Loss vs. Drain Voltage

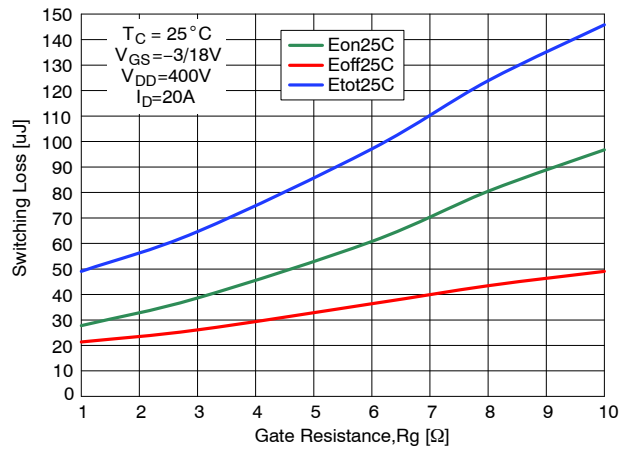

Figure 18. Switching Loss vs. Gate Resistance

# NTBL023N065M3S

## TYPICAL CHARACTERISTICS

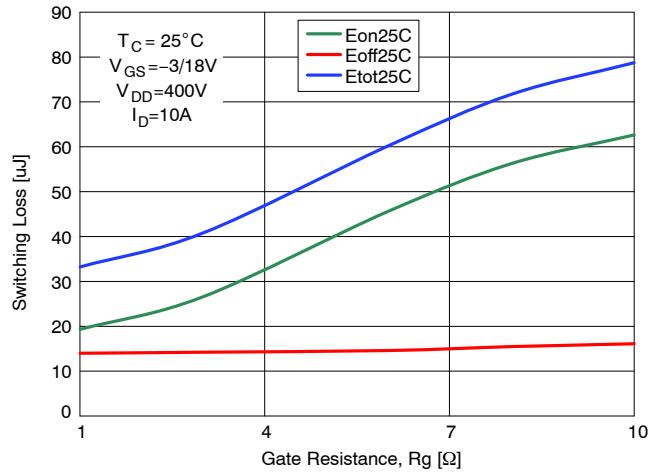

Figure 19. Switching Loss vs. Gate Resistance

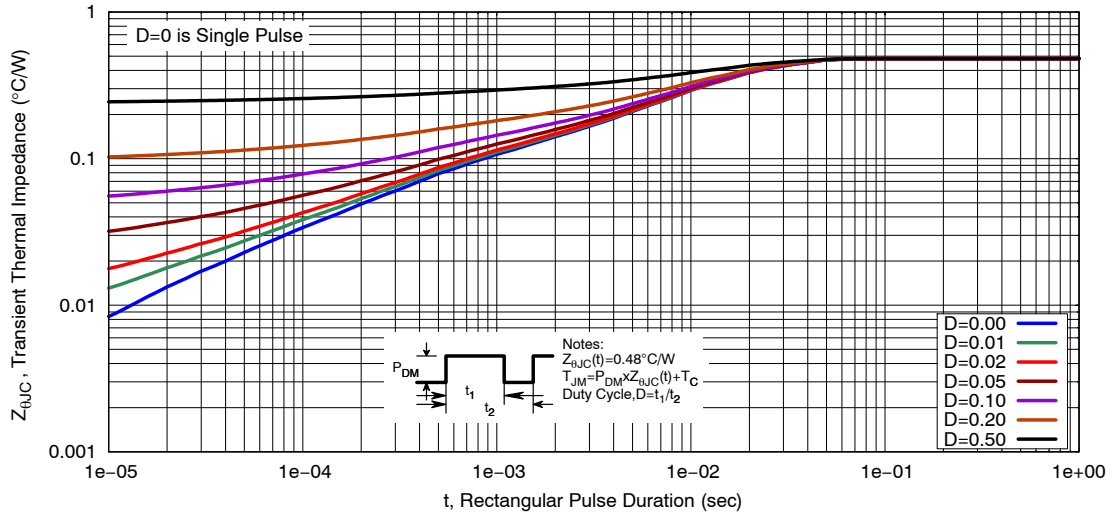

Figure 20. Thermal Response Characteristics

### DEVICE ORDERING INFORMATION

Device	Package	Shipping <sup>†</sup>
NTBL023N065M3S	H-PSOF8L	2000 / Tape & Reel

<sup>†</sup> For information on tape and reel specifications, including part orientation and tape sizes, please refer to our Tape and Reel Packaging Specifications Brochure, [BRD8011/D](#).

# NTBL023N065M3S

## REVISION HISTORY

Revision	Description of Changes	Date
2	Updated static and dynamic gate source voltage ratings in maximum ratings table.	6/15/2026

This document has undergone updates prior to the inclusion of this revision history table. The changes tracked here only reflect updates made on the noted approval dates.

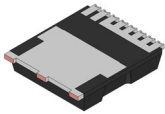

H-PSOF8L 9.90x10.38x2.30, 1.20P  
CASE 100DC  
ISSUE D

DATE 30 JUL 2024

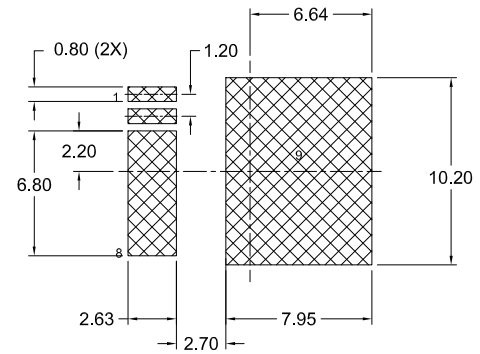
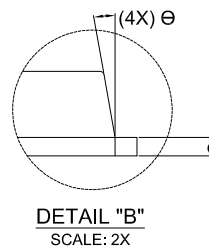
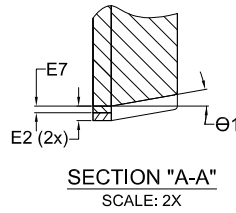
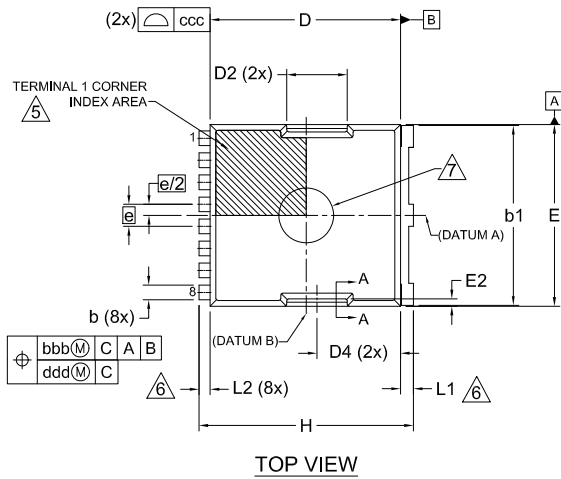

LAND PATTERN RECOMMENDATION  
\*FOR ADDITIONAL INFORMATION ON OUR Pb-FREE STRATEGY AND SOLDERING DETAILS, PLEASE DOWNLOAD THE ONSEMI SOLDERING AND MOUNTING TECHNIQUES REFERENCE MANUAL, SOLDERRM/D.

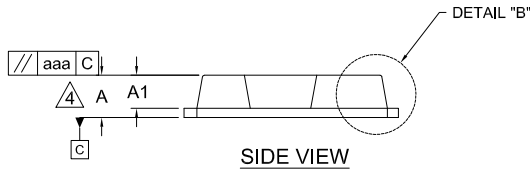

- NOTES:
1. PACKAGE STANDARD REFERENCE: JEDEC MO-299, ISSUE B.
  2. DIMENSIONING AND TOLERANCING PER ASME Y14.5M, 2018.
  3. "e" REPRESENTS THE TERMINAL PITCH.
  4. THIS DIMENSION INCLUDES ENCAPSULATION THICKNESS "A1", AND PACKAGE BODY THICKNESS, BUT DOES NOT INCLUDE ATTACHED FEATURES, e.g., EXTERNAL OR CHIP CAPACITORS. AN INTEGRAL HEATSLUG IS NOT CONSIDERED AS ATTACHED FEATURE.
  5. A VISUAL INDEX FEATURE MUST BE LOCATED WITHIN THE HATCHED AREA.
  6. DIMENSIONS b1, L1, L2 APPLY TO PLATED TERMINALS.
  7. THE LOCATION AND SIZE OF EJECTOR MARKS ARE OPTIONAL.
  8. THE LOCATION AND NUMBER OF FUSED LEADS ARE OPTIONAL.

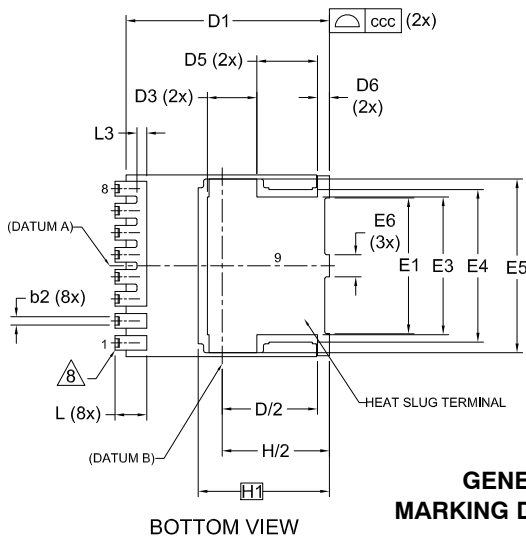

GENERIC MARKING DIAGRAM\*



XXXX = Specific Device Code  
A = Assembly Location  
Y = Year  
WW = Work Week  
ZZ = Assembly Lot Code

\*This information is generic. Please refer to device data sheet for actual part marking. Pb-Free indicator, "G" or microdot "▪", may or may not be present. Some products may not follow the Generic Marking.

DIM	MILLIMETERS		
	MIN.	NOM.	MAX.
A	2.20	2.30	2.40
A1	1.70	1.80	1.90
b	0.70	0.80	0.90
b1	9.70	9.80	9.90
b2	0.35	0.45	0.55
c	0.40	0.50	0.60
D	10.28	10.38	10.48
D/2	5.09	5.19	5.29
D1	10.98	11.08	11.18
D2	3.20	3.30	3.40
D3	2.60	2.70	2.80
D4	4.45	4.55	4.65
D5	3.20	3.30	3.40
D6	0.55	0.65	0.75
E	9.80	9.90	10.00
E1	7.30	7.40	7.50
E2	0.30	0.40	0.50
E3	7.40	7.50	7.60
E4	8.20	8.30	8.40

DIM	MILLIMETERS		
	MIN.	NOM.	MAX.
E5	9.36	9.46	9.56
E6	1.10	1.20	1.30
E7	0.15	0.18	0.21
e	1.20 BSC		
e/2	0.60 BSC		
H	11.58	11.68	11.78
H/2	5.74	5.84	5.94
H1	7.15 BSC		
L	1.63	1.73	1.83
L1	0.60	0.70	0.80
L2	0.50	0.60	0.70
L3	0.43	0.53	0.63
theta	10° REF		
theta 1	10° REF		
aaa	0.20		
bbb	0.25		
ccc	0.20		
ddd	0.20		
eee	0.10		

DOCUMENT NUMBER:	98AON80466G	Electronic versions are uncontrolled except when accessed directly from the Document Repository. Printed versions are uncontrolled except when stamped "CONTROLLED COPY" in red.
DESCRIPTION:	H-PSOF8L 9.90x10.38x2.30, 1.20P	PAGE 1 OF 1

onsemi and ONSEMI are trademarks of Semiconductor Components Industries, LLC dba onsemi or its subsidiaries in the United States and/or other countries. onsemi reserves the right to make changes without further notice to any products herein. onsemi makes no warranty, representation or guarantee regarding the suitability of its products for any particular purpose, nor does onsemi assume any liability arising out of the application or use of any product or circuit, and specifically disclaims any and all liability, including without limitation special, consequential or incidental damages. onsemi does not convey any license under its patent rights nor the rights of others.

**onsemi**, **Onsemi**, and other names, marks, and brands are registered and/or common law trademarks of Semiconductor Components Industries, LLC dba "**onsemi**" or its affiliates and/or subsidiaries in the United States and/or other countries. **onsemi** owns the rights to a number of patents, trademarks, copyrights, trade secrets, and other intellectual property. A listing of **onsemi**'s product/patent coverage may be accessed at [www.onsemi.com/site/pdf/Patent-Marking.pdf](http://www.onsemi.com/site/pdf/Patent-Marking.pdf). **onsemi** reserves the right to make changes at any time to any products or information herein, without notice. The information herein is provided "as-is" and **onsemi** makes no warranty, representation or guarantee regarding the accuracy of the information, product features, availability, functionality, or suitability of its products for any particular purpose, nor does **onsemi** assume any liability arising out of the application or use of any product or circuit, and specifically disclaims any and all liability, including without limitation special, consequential or incidental damages. Buyer is responsible for its products and applications using **onsemi** products, including compliance with all laws, regulations and safety requirements or standards, regardless of any support or applications information provided by **onsemi**. "Typical" parameters which may be provided in **onsemi** data sheets and/or specifications can and do vary in different applications and actual performance may vary over time. All operating parameters, including "Typicals" must be validated for each customer application by customer's technical experts. **onsemi** does not convey any license under any of its intellectual property rights nor the rights of others. **onsemi** products are not designed, intended, or authorized for use as a critical component in life support systems or any FDA Class 3 medical devices or medical devices with a same or similar classification in a foreign jurisdiction or any devices intended for implantation in the human body. Should Buyer purchase or use **onsemi** products for any such unintended or unauthorized application, Buyer shall indemnify and hold **onsemi** and its officers, employees, subsidiaries, affiliates, and distributors harmless against all claims, costs, damages, and expenses, and reasonable attorney fees arising out of, directly or indirectly, any claim of personal injury or death associated with such unintended or unauthorized use, even if such claim alleges that **onsemi** was negligent regarding the design or manufacture of the part. **onsemi** is an Equal Opportunity/Affirmative Action Employer. This literature is subject to all applicable copyright laws and is not for resale in any manner.

## ADDITIONAL INFORMATION

### TECHNICAL PUBLICATIONS:

Technical Library: [www.onsemi.com/design/resources/technical-documentation](http://www.onsemi.com/design/resources/technical-documentation)  
onsemi Website: [www.onsemi.com](http://www.onsemi.com)

### ONLINE SUPPORT: [www.onsemi.com/support](http://www.onsemi.com/support)

For additional information, please contact your local Sales Representative at [www.onsemi.com/support/sales](http://www.onsemi.com/support/sales)