

4-Bit Dual-Supply Level Translator

NL3V4T244, NL3V4T240, NL3V4T3144

The NL3V4T244 / NL3V4T240 / NL3V4T3144 are 4-bit configurable dual-supply level translators with 3-state outputs. The A- and B- ports are designed to track two different power supply rails, V_{CCA} and V_{CCB} respectively. Both supply rails are configurable from 0.9 V to 3.6 V allowing universal voltage level translation between the A- to B- ports.

The NL3V4T244 is a 4-bit level translator that allows non-inverting translations from A to B ports. The NL3V4T240 is a 4-bit level translator that allows inverting translations from A to B ports. The NL3V4T3144 is a 4-bit level translator that allows 3-bits of non-inverting translations from A to B ports and 1 bit of non-inverting translation from B to A.

The output enable pin (\overline{OE}), when High, disables all the output ports by putting them in 3-state. The \overline{OE} pin is designed to track V_{CCA} .

Features

- Wide V_{CCA} and V_{CCB} Operating Range: 0.9 V to 3.6 V
- Balanced Output Drive: ± 24 mA @ 3.0 V
- High-Speed w/ Balanced Propagation Delay: 2.8 ns max at 3.0 to 3.6 V
- Input/Output Pins OVT to 3.6 V
- Non-preferential V_{CC} Sequencing
- Outputs at 3-State until Active V_{CC} is Reached
- Partial Power-Off Protection
- Outputs Switch to 3-State with either V_{CC} at GND
- Typical Max Data Rates:
 - 380 Mbps (≥ 1.8 -V to 3.3-V Translation)
 - 200 Mbps (≥ 1.1 -V to [1.8-V, 2.5-V, 3.3-V] Translation)
 - 150 Mbps (≥ 1.1 -V to 1.5-V Translation)
 - 100 Mbps (≥ 1.1 -V to 1.2-V Translation)
- Small Pb-Free Packaging: TSSOP-14, SOIC-14, UQFN12
- -Q Suffix for Automotive and Other Applications Requiring Unique Site and Control Change Requirements; AEC-Q100 Qualified and PPAP Capable*
- These Devices are Pb-Free, Halogen Free/BFR Free and are RoHS Compliant

Typical Applications

- Mobile Phones, PDAs, Other Portable Devices
- Automotive
- Industrial

MARKING DIAGRAMS

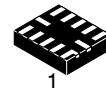

UQFN12
MU SUFFIX
CASE 523AE

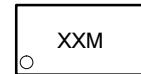

XX = Specific Device Code
 M = Date Code

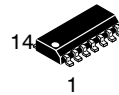

SOIC-14
D SUFFIX
CASE 751A

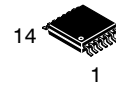
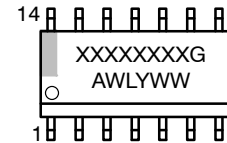

TSSOP-14
DT SUFFIX
CASE 948G

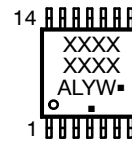

A = Assembly Location
 WL, L = Wafer Lot
 Y = Year
 WW, W = Work Week
 G or ■ = Pb-Free Package

(Note: Microdot may be in either location)

ORDERING INFORMATION

See detailed ordering and shipping information in the package dimensions section on page 9 of this data sheet.

NL3V4T244, NL3V4T240, NL3V4T3144

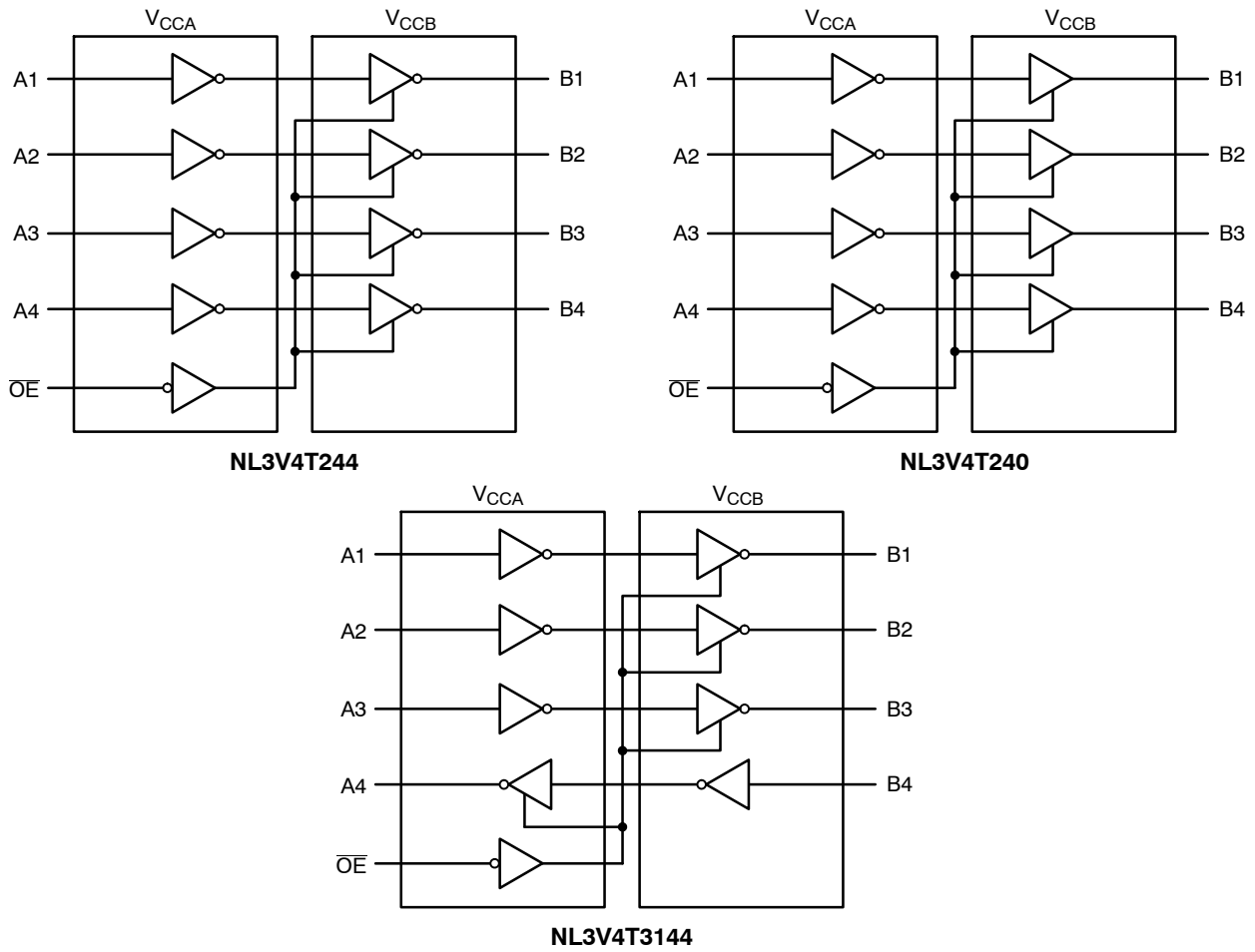

Figure 1. Logic Diagrams

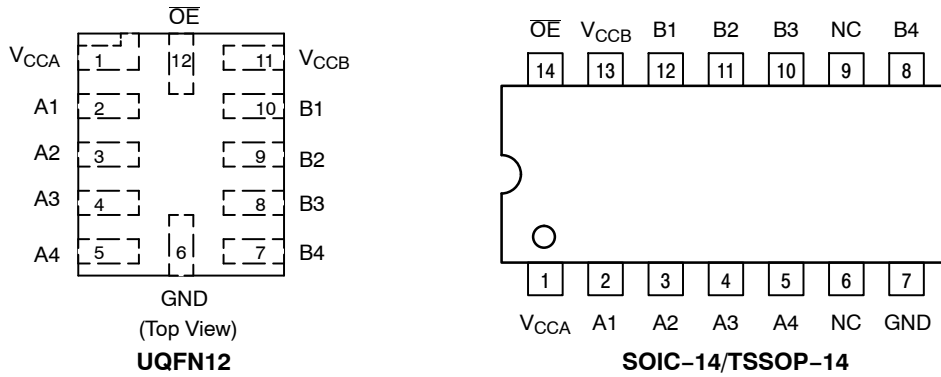

Figure 2. Pin Assignments (Top View)

NL3V4T244, NL3V4T240, NL3V4T3144

FUNCTION TABLE – NL3V4T244

Inputs		Output
\overline{OE}	A_n	B_n
L	L	L
L	H	H
H	X	3-State

FUNCTION TABLE – NL3V4T240

Inputs		Output
\overline{OE}	A_n	B_n
L	L	H
L	H	L
H	X	3-State

FUNCTION TABLE – NL3V4T3144

Inputs		Output
\overline{OE}	A1,A2,A3,B4	B1,B2,B3,A4
L	L	L
L	H	H
H	X	3-State

PIN ASSIGNMENT – NL3V4T244, NL3V4T240

PIN	FUNCTION
V_{CCA}	A-Port DC Power Supply
V_{CCB}	B-Port DC Power Supply
GND	Ground
\overline{OE}	Output Enable
A1, A2, A3, A4	Input Ports
B1, B2, B3, B4	Output Ports

PIN ASSIGNMENT – NL3V4T3144

PIN	FUNCTION
V_{CCA}	A-Port DC Power Supply
V_{CCB}	B-Port DC Power Supply
GND	Ground
\overline{OE}	Output Enable
A1, A2, A3, B4	Input Ports
B1, B2, B3, A4	Output Ports

Application Recommendations

During power-up and power-down, it is recommended that the \overline{OE} pin be connected to V_{CC} through pull-up resistors to ensure high impedance at the I/O ports.

NL3V4T244, NL3V4T240, NL3V4T3144

MAXIMUM RATINGS

Symbol	Rating	Value	Condition	Unit
V_{CCA}, V_{CCB}	DC Supply Voltage	-0.5 to +4.3		V
V_I	DC Input Voltage	OE, A, B	-0.5 to +4.3	V
V_O	DC Output Voltage	(Power Down Mode) A, B	-0.5 to +4.3	V
		(3-State Mode) A, B	-0.5 to +4.3	
		(Active Mode) A	-0.5 to $V_{CCA}+0.5$	
		(Active Mode) B	-0.5 to $V_{CCB}+0.5$	
I_{IK}	DC Input Diode Current	-50	$V_I < \text{GND}$	mA
I_{OK}	DC Output Diode Current	-50	$V_O < \text{GND}$	mA
I_O	DC Output Source/Sink Current	± 50		mA
I_{CC}	DC Supply Current Per Supply Pin	± 100		mA
I_{GND}	DC Ground Current per Ground Pin	± 100		mA
T_{STG}	Storage Temperature Range	-65 to +150		$^{\circ}\text{C}$
θ_{JA}	Thermal Resistance (Note 1)	SOIC-14 TSSOP-14 UQFN12	116 150 143	$^{\circ}\text{C}/\text{W}$
P_D	Power Dissipation in Still Air	SOIC-14 TSSOP-14 UQFN12	1077 833 875	mW
MSL	Moisture Sensitivity Level		Level 1	-
F_R	Flammability Rating	Oxygen Index: 28 to 34	UL 94 V-0 @ 0.125 in	-
V_{ESD}	ESD Withstand Voltage (Note 2)	Human Body Model Charged Device Model	2 1	kV
$I_{LATCHUP}$	Latchup Performance (Note 3)		± 100	mA

Stresses exceeding those listed in the Maximum Ratings table may damage the device. If any of these limits are exceeded, device functionality should not be assumed, damage may occur and reliability may be affected.

1. Measured with minimum pad spacing on an FR4 board, using 76mm-by-114mm, 2-ounce copper trace no air flow per JESD51-7.
2. HBM tested to ANSI/ESDA/JEDEC JS-001-2017. CDM tested to EIA/JESD22-C101-A. JEDEC recommends that ESD qualification to EIA/JESD22-A115A (Machine Model) be discontinued per JEDEC/JEP172A.
3. Tested to EIA/JESD78 Class II.

RECOMMENDED OPERATING CONDITIONS

Symbol	Parameter	Min	Max	Unit
V_{CCA}, V_{CCB}	Positive DC Supply Voltage	0.9	3.6	V
V_I	Input Voltage	GND	3.6	V
V_{IO}	Output Voltage	(Power Down Mode) A, B	GND	V
		(3-State Mode) A, B	GND	
		(Active Mode) A	GND	
		(Active Mode) B	GND	
T_A	Operating Temperature Range	-40	+125	$^{\circ}\text{C}$
$\Delta t / \Delta V$	Input Transition Rise or Rate	0	5	nS/V

Functional operation above the stresses listed in the Recommended Operating Ranges is not implied. Extended exposure to stresses beyond the Recommended Operating Ranges limits may affect device reliability.

NL3V4T244, NL3V4T240, NL3V4T3144

DC ELECTRICAL CHARACTERISTICS – INPUT VOLTAGES

Symbol	Parameter	Test Conditions	Port	V _{CCA} (V)	V _{CCB} (V)	-40°C to +85°C			-40°C to +125°C		Unit	
						Min	Typ (Note 4)	Max	Min	Max		
V _{IH}	Input HIGH Voltage		OE, A	2.7 – 3.6	0.9 – 3.6	2.0	–	–	2.0	–	V	
				2.3 – 2.7		1.6	–	–	1.6	–		
				1.65 – 1.95		0.65 V _{CCA}	–	–	0.65 V _{CCA}	–		
				1.1 – 1.6		0.7 V _{CCA}	–	–	0.7 V _{CCA}	–		
				0.9		–	0.9 V _{CCA}	–	–	–		
			B	0.9 – 3.6	2.7 – 3.6	2.0	–	–	2.0	–		V
				2.3 – 2.7	1.6	–	–	1.6	–			
				1.65 – 1.95	0.65 V _{CCB}	–	–	0.65 V _{CCB}	–			
				1.1 – 1.6	0.7 V _{CCB}	–	–	0.7 V _{CCB}	–			
				0.9	–	0.9 V _{CCB}	–	–	–			
V _{IL}	Input LOW Voltage		OE, A	2.7 – 3.6	0.9 – 3.6	–	–	0.8	–	0.8	V	
				2.3 – 2.7		–	–	0.7	–	0.7		
				1.65 – 1.95		–	–	0.35 V _{CCA}	–	0.35 V _{CCA}		
				1.1 – 1.6		–	–	0.3 V _{CCA}	–	0.3 V _{CCA}		
				0.9		–	0.1 V _{CCA}	–	–	–		
			B	0.9 – 3.6	2.7 – 3.6	–	–	0.8	–	0.8		V
				2.3 – 2.7	–	–	0.7	–	0.7			
				1.65 – 1.95	–	–	0.35 V _{CCB}	–	0.35 V _{CCB}			
				1.1 – 1.6	–	–	0.3 V _{CCB}	–	0.3 V _{CCB}			
				0.9	–	0.1 V _{CCB}	–	–	–			

4. All typical values are at T_A = 25°C.

NL3V4T244, NL3V4T240, NL3V4T3144

DC ELECTRICAL CHARACTERISTICS – OUTPUT VOLTAGES

Symbol	Parameter	Test Conditions	V _{CCA} (V)	V _{CCB} (V)	-40°C to +85°C			-40°C to +125°C		Unit	
					Min	Typ (Note 4)	Max	Min	Max		
V _{OH}	Output HIGH Voltage	V _I = V _{IH} or V _{IL} :								V	
		I _{OH} = -100 μA	A	0.9	0.9	-	V _{CCA} - 0.1	-	-		-
			B	0.9	0.9	-	V _{CCB} - 0.1	-	-		-
		I _{OH} = -3 mA	A	1.1 - 3.6	1.1 - 3.6	V _{CCA} - 0.1	-	-	V _{CCA} - 0.1		-
			B			V _{CCB} - 0.1	-	-	V _{CCB} - 0.1		-
		I _{OH} = -6 mA		1.1	1.1	0.85	-	-	0.85		-
		I _{OH} = -8 mA		1.4	1.4	1.05	-	-	1.05		-
		I _{OH} = -8 mA		1.65	1.65	1.2	-	-	1.2		-
		I _{OH} = -12 mA		2.3	2.3	1.8	-	-	1.8		-
				2.7	2.7	2.2	-	-	2.2		-
		I _{OH} = -18 mA		2.3	2.3	1.7	-	-	1.7		-
	3.0		3.0	2.4	-	-	2.4	-			
I _{OH} = -24 mA		3.0	3.0	2.2	-	-	2.2	-			
V _{OL}	Output LOW Voltage	V _I = V _{IH} or V _{IL} :								V	
		I _{OL} = 100 μA		0.9	0.9	-	0.1	-	-		-
			1.1 - 3.6	1.1 - 3.6	-	-	0.1	-	0.1		
		I _{OL} = 3 mA		1.1	1.1	-	-	0.25	-		0.25
		I _{OL} = 6 mA		1.4	1.4	-	-	0.35	-		0.35
		I _{OL} = 8 mA		1.65	1.65	-	-	0.3	-		0.3
				2.3	2.3	-	-	0.4	-		0.4
		I _{OL} = 12 mA		2.7	2.7	-	-	0.4	-		0.4
				2.3	2.3	-	-	0.4	-		0.4
		I _{OL} = 18 mA		3.0	3.0	-	-	0.4	-		0.4
				3.0	3.0	-	-	0.55	-		0.55

DC ELECTRICAL CHARACTERISTICS – LEAKAGE AND SUPPLY CURRENTS

Symbol	Parameter	Test Conditions	V _{CCA} (V)	V _{CCB} (V)	-40°C to +85°C		-40°C to +125°C		Unit	
					Min	Max	Min	Max		
I _I	Input Leakage Current	V _I = 3.6 V or GND	0.9 - 3.6	0.9 - 3.6	-	±1.0	-	±5.0	μA	
I _{OZ}	3-State Output Leakage	\overline{OE} = V _{IH} ; V _O = GND to 3.6 V	3.6	3.6	-	±1.0	-	±5.0	μA	
I _{OFF}	Power-Off Leakage Current	V _I or V _O = 0 to 3.6 V	A	0	0.9 - 3.6	-	±1.0	-	±5.0	μA
			B	0.9 - 3.6	0	-	±1.0	-	±5.0	
I _{CCA}	Quiescent Supply Current	V _I = V _{CCA} or GND; I _O = 0	0.9 - 3.6	0.9 - 3.6	-	5.0	-	10	μA	
			0	0.9 - 3.6	-	-1.0	-	-5.0		
			0.9 - 3.6	0	-	5.0	-	10		
I _{CCB}	Quiescent Supply Current	V _I = V _{CCB} or GND; I _O = 0	0.9 - 3.6	0.9 - 3.6	-	5.0	-	10	μA	
			0	0.9 - 3.6	-	5.0	-	10		
			0.9 - 3.6	0	-	-1.0	-	-5.0		

NOTE: Connect ground before applying supply voltage V_{CCA} or V_{CCB}. This device is designed with the feature that the power-up sequence of V_{CCA} and V_{CCB} will not damage the IC.

NL3V4T244, NL3V4T240, NL3V4T3144

AC ELECTRICAL CHARACTERISTICS (Notes 5 and 6)

Symbol	Parameter	V _{CCA} (V)	T _A = -40°C to +85°C					T _A = -40°C to +125°C					Unit
			V _{CCB} (V)					V _{CCB} (V)					
			3.3	2.5	1.8	1.5	1.2	3.3	2.5	1.8	1.5	1.2	
			Max	Max	Max	Max	Max	Max	Max	Max	Max	Max	
t _{PLH} , t _{PHL}	Propagation Delay, A to B	3.3	2.9	3.3	4.5	5.6	9.3	3.3	3.8	5.0	6.2	9.5	nS
		2.5	3.6	3.7	4.6	5.7	9.4	4.0	4.0	5.1	6.3	9.6	
		1.8	3.9	4.0	4.9	6.0	9.6	4.3	4.3	5.4	6.6	9.8	
		1.5	4.2	4.3	5.2	6.3	9.8	4.7	4.7	5.8	7.0	10.0	
		1.2	5.1	5.2	6.2	7.1	11.0	5.7	5.8	6.9	7.9	11.2	
	Propagation Delay, B to A	3.3	2.8	3.0	3.4	4.2	5.1	3.3	3.4	3.9	4.7	5.7	
		2.5	3.3	3.4	3.9	4.2	5.2	3.8	3.9	4.3	4.7	5.8	
		1.8	4.5	4.6	4.9	5.3	6.2	5.0	5.1	5.4	5.9	6.9	
		1.5	5.6	5.7	6.0	6.3	7.1	6.2	6.3	6.6	7.9	7.9	
		1.2	9.3	9.4	9.6	9.8	11.0	9.5	9.6	9.8	10.0	11.2	
t _{PZH} , t _{PZL}	Output Enable, OE to A	3.3	3.8	3.8	3.8	4.3	5.7	4.2	4.2	4.2	4.5	5.8	nS
		2.5	4.8	4.8	4.8	4.9	6.2	5.3	5.3	5.3	5.3	6.3	
		1.8	7.2	7.2	7.2	7.2	7.5	8.0	8.0	8.0	8.0	8.0	
		1.5	9.4	9.4	9.4	9.4	9.4	10.4	10.4	10.4	10.4	10.4	
		1.2	12.8	12.8	12.8	12.8	13.4	14.1	14.1	14.1	14.1	14.1	
	Output Enable, OE to B	3.3	3.8	4.7	6.8	8.7	11.6	4.2	5.2	7.5	9.6	12.4	
		2.5	4.0	4.8	7.0	8.8	11.6	4.4	5.3	7.7	9.7	12.4	
		1.8	4.6	5.3	7.4	9.2	11.9	5.1	5.9	8.2	10.2	12.9	
		1.5	5.6	5.8	7.7	9.6	12.5	6.2	6.4	8.5	10.6	13.3	
		1.2	7.7	7.9	8.9	10.0	13.9	8.5	8.7	9.8	11.0	14.7	
t _{PHZ} , t _{PLZ}	Output Disable, OE to A	3.3	5.6	5.6	5.6	5.6	5.6	6.2	6.2	6.2	6.2	6.2	nS
		2.5	6.2	6.2	6.2	6.2	6.2	6.9	6.9	6.9	6.9	6.9	
		1.8	8.6	8.6	8.6	8.6	8.6	9.5	9.5	9.5	9.5	9.5	
		1.5	10.2	10.2	10.2	10.2	10.2	11.3	11.3	11.3	11.3	11.3	
		1.2	10.9	10.9	10.9	10.9	10.9	12.0	12.0	12.0	12.0	12.0	
	Output Disable, OE to B	3.3	6.2	6.4	8.1	9.3	10.2	6.9	7.1	9.0	10.3	11.3	
		2.5	5.2	6.2	8.2	8.8	10.4	5.8	6.9	9.1	10.4	11.5	
		1.8	6.9	6.9	8.7	9.9	10.9	7.6	7.6	9.6	10.9	12.0	
		1.5	7.6	7.4	9.1	10.3	11.3	8.2	8.4	10.1	11.4	12.5	
		1.2	8.1	8.1	9.5	9.6	12.4	9.0	10.1	10.5	10.6	13.7	

5. Propagation delays defined per Figure 3.

6. These parameters are guaranteed by characterization and are not production tested.

CAPACITANCE

Symbol	Parameter	Test Conditions	Typ (Note 4)	Unit
C _{IN}	Control Pin Input Capacitance	V _{CCA} = V _{CCB} = 3.3 V, V _I = 0 V or V _{CCA}	2.5	pF
C _{I/O}	I/O Pin Input Capacitance	V _{CCA} = V _{CCB} = 3.3 V, V _I = 0 V or V _{CCA}	5.0	pF
C _{PD} (Note 7)	Power Dissipation Capacitance	V _{CCA} = V _{CCB} = 3.3 V, V _I = 0 V or V _{CCA} , f = 10 MHz	12	pF

7. C_{PD} is defined as the value of the IC's equivalent capacitance from which the operating current can be calculated from:
 $I_{CC(operating)} \cong C_{PD} \times V_{CC} \times f_{IN} \times N_{SW}$ where $I_{CC} = I_{CCA} + I_{CCB}$ and N_{SW} = total number of outputs switching.

NL3V4T244, NL3V4T240, NL3V4T3144

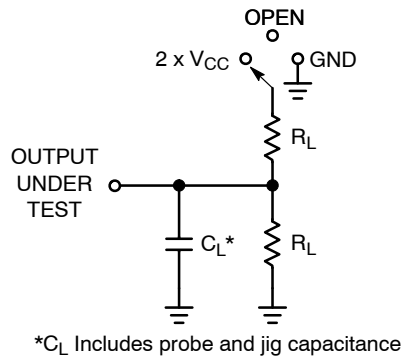

Figure 3. AC Test Circuit

Test	Switch	C _L	R _L
t _{PLH} , t _{PHL}	OPEN	15 pF	2 kΩ
t _{PLZ} , t _{PZL}	2 x V _{CC}		
t _{PHZ} , t _{PZH}	GND		

C_L includes probe and jig capacitance
Pulse generator Z_O = 50 Ω
Input f = 1.0 MHz; t_W = 500 ns

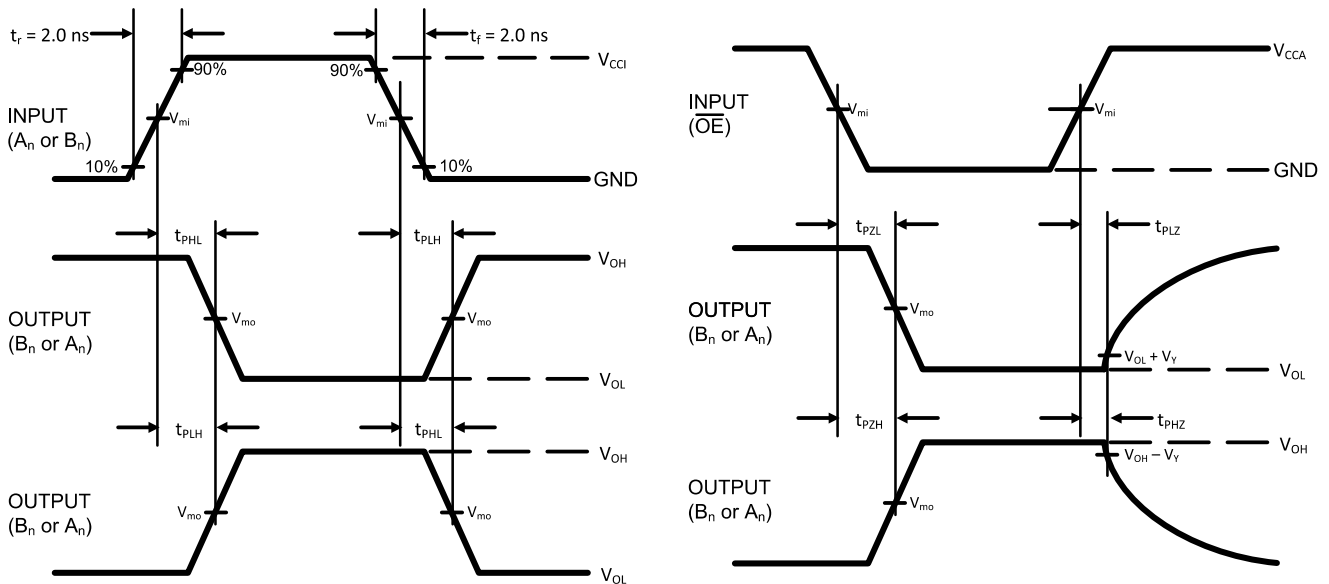

Figure 4. AC Waveforms

Symbol	V _{CC}				
	3.0 V – 3.6 V	2.3 V – 2.7 V	1.65 V – 1.95 V	1.4 V – 1.6 V	1.1 V – 1.3 V
V _{mi}	V _{CCi} /2	V _{CCi} /2	V _{CCi} /2	V _{CCi} /2	V _{CCi} /2
V _{mo}	V _{CCo} /2	V _{CCo} /2	V _{CCo} /2	V _{CCo} /2	V _{CCo} /2
V _Y	0.3 V	0.15 V	0.15 V	0.1 V	0.1 V

8. V_{CCi} is the V_{CC} associated with the input port.
9. V_{CCo} is the V_{CC} associated with the output port.

NL3V4T244, NL3V4T240, NL3V4T3144

ORDERING INFORMATION

Device	Marking	Package	Pin 1 Quadrant	Shipping [†]
NL3V4T244MU2TAG	AG	UQFN12	1	3000 Units / Tape & Reel
NL3V4T244MU2TAG-Q*	AG	UQFN12	1	3000 Units / Tape & Reel
NL3V4T244DR2G (Contact onsemi sales)	TBD	SOIC-14	TBD	2500 Units / Tape & Reel
NL3V4T244DTR2G (Contact onsemi sales)	TBD	TSSOP-14	TBD	2500 Units / Tape & Reel
NL3V4T240MU2TAG	AJ	UQFN12	1	3000 Units / Tape & Reel
NL3V4T240DR2G (Contact onsemi sales)	TBD	SOIC-14	TBD	2500 Units / Tape & Reel
NL3V4T240DTR2G (Contact onsemi sales)	TBD	TSSOP-14	TBD	2500 Units / Tape & Reel
NL3V4T3144MU2TAG	AE	UQFN12	1	3000 Units / Tape & Reel

[†]For information on tape and reel specifications, including part orientation and tape sizes, please refer to our Tape and Reel Packaging Specifications Brochure, BRD8011/D.

*-Q Suffix for Automotive and Other Applications Requiring Unique Site and Control Change Requirements; AEC-Q100 Qualified and PPAP Capable.

Pin 1 Orientation in Tape and Reel

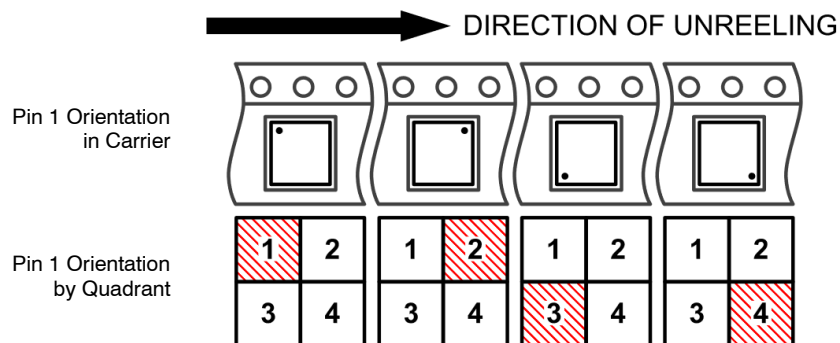

NL3V4T244, NL3V4T240, NL3V4T3144

PACKAGE DIMENSIONS

UQFN12 1.7x2.0, 0.4P
CASE 523AE
ISSUE A

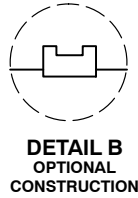
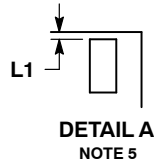
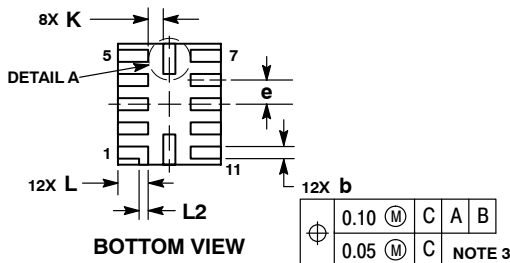
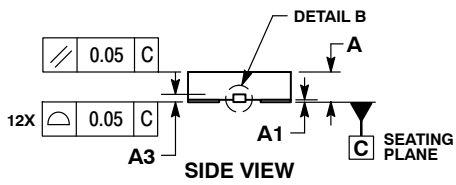
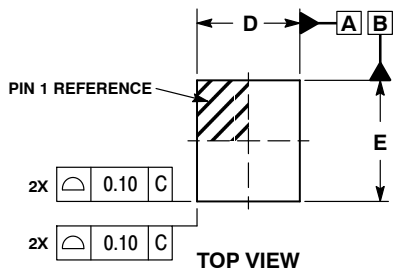

NOTES:

1. DIMENSIONING AND TOLERANCING PER ASME Y14.5M, 1994.
2. CONTROLLING DIMENSION: MILLIMETERS
3. DIMENSION b APPLIES TO PLATED TERMINAL AND IS MEASURED BETWEEN 0.15 AND 0.30 MM FROM TERMINAL TIP.
4. MOLD FLASH ALLOWED ON TERMINALS ALONG EDGE OF PACKAGE. FLASH 0.03 MAX ON BOTTOM SURFACE OF TERMINALS.
5. DETAIL A SHOWS OPTIONAL CONSTRUCTION FOR TERMINALS.

MILLIMETERS		
DIM	MIN	MAX
A	0.45	0.55
A1	0.00	0.05
A3	0.127 REF	
b	0.15	0.25
D	1.70 BSC	
E	2.00 BSC	
e	0.40 BSC	
K	0.20	----
L	0.45	0.55
L1	0.00	0.03
L2	0.15 REF	

**MOUNTING FOOTPRINT
SOLDERMASK DEFINED**

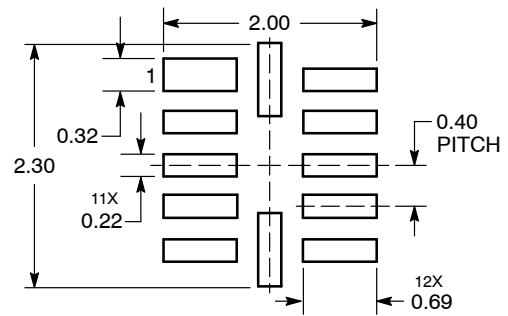

DIMENSIONS: MILLIMETERS

*For additional information on our Pb-Free strategy and soldering details, please download the **onsemi** Soldering and Mounting Techniques Reference Manual, SOLDERRM/D.

NL3V4T244, NL3V4T240, NL3V4T3144

PACKAGE DIMENSIONS

SOIC-14
D SUFFIX
CASE 751A-03
ISSUE L

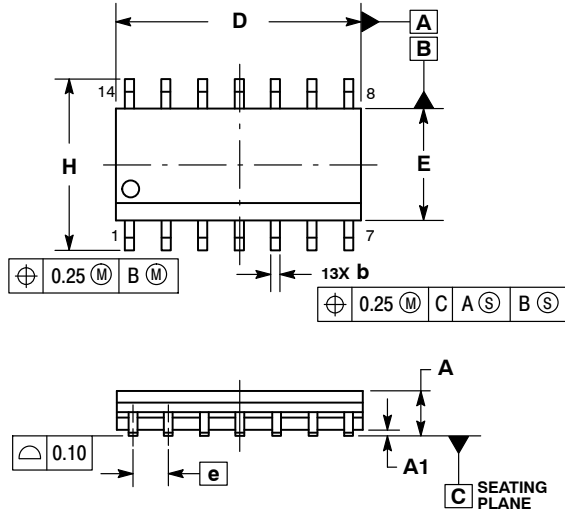

NOTES:

1. DIMENSIONING AND TOLERANCING PER ASME Y14.5M, 1994.
2. CONTROLLING DIMENSION: MILLIMETERS.
3. DIMENSION b DOES NOT INCLUDE DAMBAR PROTRUSION. ALLOWABLE PROTRUSION SHALL BE 0.13 TOTAL IN EXCESS OF AT MAXIMUM MATERIAL CONDITION.
4. DIMENSIONS D AND E DO NOT INCLUDE MOLD PROTRUSIONS.
5. MAXIMUM MOLD PROTRUSION 0.15 PER SIDE.

DIM	MILLIMETERS		INCHES	
	MIN	MAX	MIN	MAX
A	1.35	1.75	0.054	0.068
A1	0.10	0.25	0.004	0.010
A3	0.19	0.25	0.008	0.010
b	0.35	0.49	0.014	0.019
D	8.55	8.75	0.337	0.344
E	3.80	4.00	0.150	0.157
e	1.27 BSC		0.050 BSC	
H	5.80	6.20	0.228	0.244
h	0.25	0.50	0.010	0.019
L	0.40	1.25	0.016	0.049
M	0°	7°	0°	7°

SOLDERING FOOTPRINT*

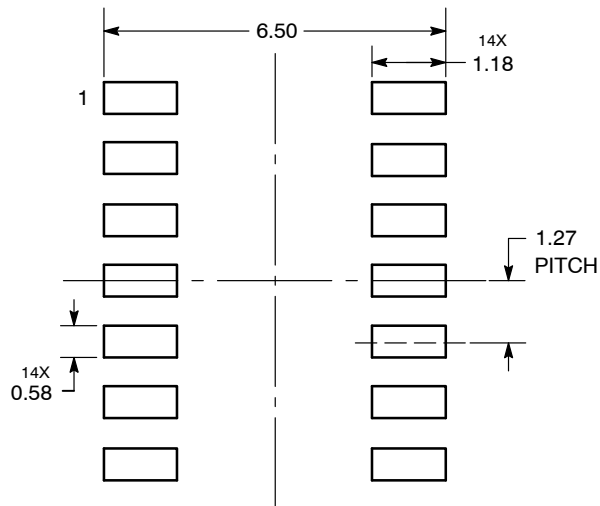

DIMENSIONS: MILLIMETERS

*For additional information on our Pb-Free strategy and soldering details, please download the **onsemi** Soldering and Mounting Techniques Reference Manual, SOLDERRM/D.

NL3V4T244, NL3V4T240, NL3V4T3144

PACKAGE DIMENSIONS

TSSOP-14
DT SUFFIX
CASE 948G
ISSUE C

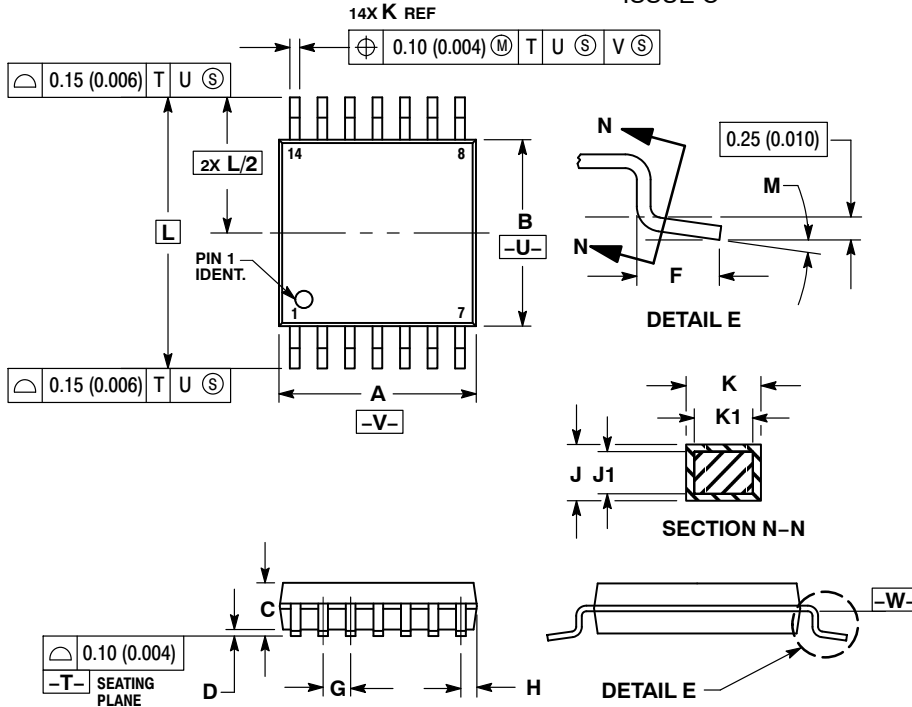

NOTES:

1. DIMENSIONING AND TOLERANCING PER ANSI Y14.5M, 1982.
2. CONTROLLING DIMENSION: MILLIMETER.
3. DIMENSION A DOES NOT INCLUDE MOLD FLASH, PROTRUSIONS OR GATE BURRS. MOLD FLASH OR GATE BURRS SHALL NOT EXCEED 0.15 (0.006) PER SIDE.
4. DIMENSION B DOES NOT INCLUDE INTERLEAD FLASH OR PROTRUSION. INTERLEAD FLASH OR PROTRUSION SHALL NOT EXCEED 0.25 (0.010) PER SIDE.
5. DIMENSION K DOES NOT INCLUDE DAMBAR PROTRUSION. ALLOWABLE DAMBAR PROTRUSION SHALL BE 0.08 (0.003) TOTAL IN EXCESS OF THE K DIMENSION AT MAXIMUM MATERIAL CONDITION.
6. TERMINAL NUMBERS ARE SHOWN FOR REFERENCE ONLY.
7. DIMENSION A AND B ARE TO BE DETERMINED AT DATUM PLANE -W-.

DIM	MILLIMETERS		INCHES	
	MIN	MAX	MIN	MAX
A	4.90	5.10	0.193	0.200
B	4.30	4.50	0.169	0.177
C	---	1.20	---	0.047
D	0.05	0.15	0.002	0.006
F	0.50	0.75	0.020	0.030
G	0.65 BSC		0.026 BSC	
H	0.50	0.60	0.020	0.024
J	0.09	0.20	0.004	0.008
J1	0.09	0.16	0.004	0.006
K	0.19	0.30	0.007	0.012
K1	0.19	0.25	0.007	0.010
L	6.40 BSC		0.252 BSC	
M	0°	8°	0°	8°

SOLDERING FOOTPRINT

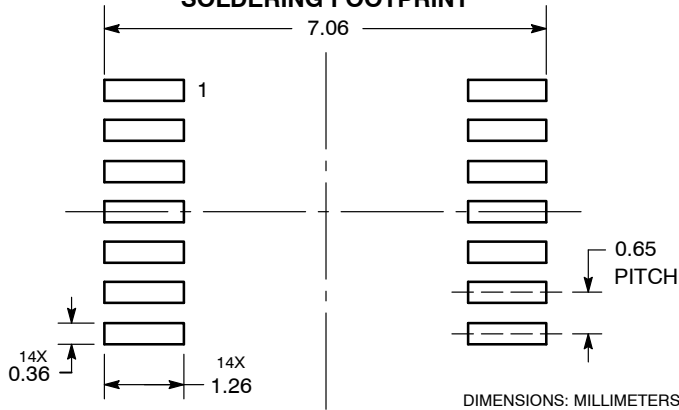

onsemi, Onsemi, and other names, marks, and brands are registered and/or common law trademarks of Semiconductor Components Industries, LLC dba "onsemi" or its affiliates and/or subsidiaries in the United States and/or other countries. onsemi owns the rights to a number of patents, trademarks, copyrights, trade secrets, and other intellectual property. A listing of onsemi's product/patent coverage may be accessed at www.onsemi.com/site/pdf/Patent-Marketing.pdf. onsemi reserves the right to make changes at any time to any products or information herein, without notice. The information herein is provided "as-is" and onsemi makes no warranty, representation or guarantee regarding the accuracy of the information, product features, availability, functionality, or suitability of its products for any particular purpose, nor does onsemi assume any liability arising out of the application or use of any product or circuit, and specifically disclaims any and all liability, including without limitation special, consequential or incidental damages. Buyer is responsible for its products and applications using onsemi products, including compliance with all laws, regulations and safety requirements or standards, regardless of any support or applications information provided by onsemi. "Typical" parameters which may be provided in onsemi data sheets and/or specifications can and do vary in different applications and actual performance may vary over time. All operating parameters, including "Typicals" must be validated for each customer application by customer's technical experts. onsemi does not convey any license under any of its intellectual property rights nor the rights of others. onsemi products are not designed, intended, or authorized for use as a critical component in life support systems or any FDA Class 3 medical devices or medical devices with a same or similar classification in a foreign jurisdiction or any devices intended for implantation in the human body. Should Buyer purchase or use onsemi products for any such unintended or unauthorized application, Buyer shall indemnify and hold onsemi and its officers, employees, subsidiaries, affiliates, and distributors harmless against all claims, costs, damages, and expenses, and reasonable attorney fees arising out of, directly or indirectly, any claim of personal injury or death associated with such unintended or unauthorized use, even if such claim alleges that onsemi was negligent regarding the design or manufacture of the part. onsemi is an Equal Opportunity/Affirmative Action Employer. This literature is subject to all applicable copyright laws and is not for resale in any manner.

ADDITIONAL INFORMATION

TECHNICAL PUBLICATIONS:

Technical Library: www.onsemi.com/design/resources/technical-documentation
onsemi Website: www.onsemi.com

ONLINE SUPPORT: www.onsemi.com/support

For additional information, please contact your local Sales Representative at www.onsemi.com/support/sales