

# Surface Mount Ultra Fast Power Rectifier

**POWERMITE®**  
**Power Surface Mount Package**

## NHPM260T3G, NRVHPM260T3G

The ultrafast Powermite provides soft recovery fast switching performance in a compact thermally efficient package. The advanced packaging techniques provide for a very efficient micro-miniature space-saving surface mount rectifier. With its unique heatsink design, the Powermite offers thermal performance similar to the SMA while being 50% smaller in footprint area.

### Features

- Fast Soft Switching for Reduced EMI and Higher Efficiency
- Low Profile – Maximum Height of 1.1 mm
- Small Footprint – Footprint Area of 8.45 mm<sup>2</sup>
- Supplied in 12 mm Tape and Reel
- Low Thermal Resistance with Direct Thermal Path of Die on Exposed Cathode Heat Sink
- These Devices are Pb-Free, Halogen Free and are RoHS Compliant

### Mechanical Characteristics:

- Powermite is JEDEC Registered as D0-216AA
- Case: Molded Epoxy
- Epoxy Meets UL 94 V-0 @ 0.125 in
- Weight: 16.3 mg (Approximately)
- Lead and Mounting Surface Temperature for Soldering Purposes: 260 °C Maximum for 10 Seconds
- MSL 1

### Applications

- Automotive HID Lighting
- Diesel Piezo Injection
- Power Factor Correction in Mini Adapters
- Freewheeling Diode Where Space is at a Premium

**ULTRA FAST  
RECTIFIER  
2.0 AMPERES, 600 VOLTS**

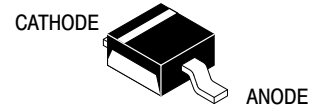

**POWERMITE  
CASE 457**

### MARKING DIAGRAM

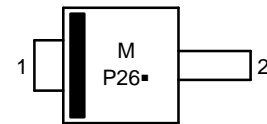

M = Date Code  
 P26 = Device Code  
 ■ = Pb-Free Package

### ORDERING INFORMATION

Device	Package	Shipping <sup>†</sup>
NRVHPM260T3G	Powermite (Pb-Free)	12000/Tape & Reel

### DISCONTINUED (Note 1)

NHPM260T3G	Powermite (Pb-Free)	12000/Tape & Reel
------------	---------------------	-------------------

<sup>†</sup> For information on tape and reel specifications, including part orientation and tape sizes, please refer to our Tape and Reel Packaging Specification Brochure, [BRD8011/D](http://www.onsemi.com/BRD8011/D).

1. **DISCONTINUED:** This device is not available. Please contact your **onsemi** representative for information. The most current information on this device may be available on [www.onsemi.com](http://www.onsemi.com).

# NHPM260T3G, NRVHPM260T3G

## MAXIMUM RATINGS

Rating	Symbol	Value	Unit
Peak Repetitive Reverse Voltage Working Peak Reverse Voltage DC Blocking Voltage	$V_{RRM}$ $V_{RWM}$ $V_R$	600	V
Average Rectified Forward Current ( $T_L = 145\text{ }^\circ\text{C}$ )	$I_O$	2.0	A
Peak Repetitive Forward Current (Square Wave, 20 kHz, $T_L = 125\text{ }^\circ\text{C}$ )	$I_{FRM}$	4.0	A
Non-Repetitive Peak Surge Current (Surge Applied at Rated Load Conditions Halfwave, Single Phase, 60 Hz)	$I_{FSM}$	15	A
Storage and Operating Junction Temperature Range (Note 2)	$T_{stg}, T_J$	-65 to +175	$^\circ\text{C}$

Stresses exceeding those listed in the Maximum Ratings table may damage the device. If any of these limits are exceeded, device functionality should not be assumed, damage may occur and reliability may be affected.

2. The heat generated must be less than the thermal conductivity from Junction-to-Ambient:  $dP_D/dT_J < 1/R_{\theta JA}$ .

## THERMAL CHARACTERISTICS

Characteristic	Symbol	Value	Unit
Thermal Resistance, Junction-to-Lead (Note 3)	$\Psi_{JCL}$	8.5	$^\circ\text{C/W}$
Thermal Resistance, Junction-to-Ambient (Note 3)	$R_{\theta JA}$	82.9	$^\circ\text{C/W}$
Thermal Resistance, Junction-to-Ambient (Note 4)	$R_{\theta JA}$	260	$^\circ\text{C/W}$

## ELECTRICAL CHARACTERISTICS

Characteristic	Test Conditions	Symbol	Typ	Max	Unit
Instantaneous Forward Voltage (Note 5)	( $I_F = 2\text{ A}, T_C = 125\text{ }^\circ\text{C}$ ) ( $I_F = 2\text{ A}, T_C = 25\text{ }^\circ\text{C}$ )	$V_F$	2.1 3.0	2.6 3.8	V
Instantaneous Reverse Current (Note 5)	(Rated DC Voltage, $T_C = 125\text{ }^\circ\text{C}$ ) (Rated DC Voltage, $T_C = 25\text{ }^\circ\text{C}$ )	$I_R$	5.0 0.002	50 0.5	$\mu\text{A}$
Reverse Recovery Time Peak Reverse Recovery Current Total Reverse Recovery Charge Softness Factor	( $I_F = 2\text{ A}, dI_F/dt = -200\text{ A}/\mu\text{s}, T_C = 25\text{ }^\circ\text{C}$ )	$t_{rr}$ $I_{RM}$ $Q_{rr}$ S	15 0.5 2.1 0.8	30 3.0 10 3.0	ns A nC -
Reverse Recovery Time Peak Reverse Recovery Current Total Reverse Recovery Charge Softness Factor	( $I_F = 2\text{ A}, dI_F/dt = -200\text{ A}/\mu\text{s}, T_C = 125\text{ }^\circ\text{C}$ )	$t_{rr}$ $I_{RM}$ $Q_{rr}$ S	30 0.7 12 2.4	- - - -	ns A nC -

Product parametric performance is indicated in the Electrical Characteristics for the listed test conditions, unless otherwise noted. Product performance may not be indicated by the Electrical Characteristics if operated under different conditions.

- Mounted with 700 mm<sup>2</sup> copper pad size (Approximately 1 in<sup>2</sup>) 1 oz FR4 Board.
- Mounted with pad size approximately 20 mm<sup>2</sup> copper, 1 oz FR4 Board.
- Pulse Test: Pulse Width  $\leq 380\text{ }\mu\text{s}$ , Duty Cycle  $\leq 2.0\%$ .

# NHPM260T3G, NRVHPM260T3G

## TYPICAL CHARACTERISTICS

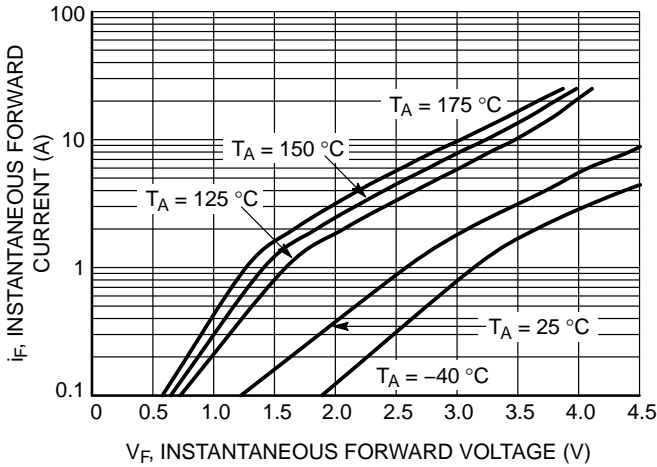

**Figure 1. Typical Instantaneous Forward Characteristics**

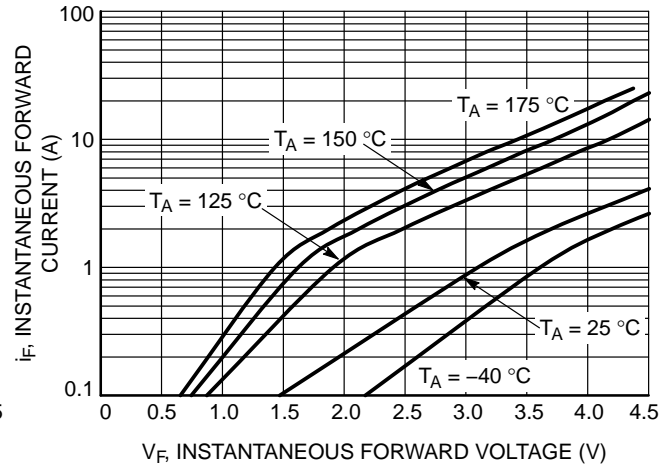

**Figure 2. Maximum Instantaneous Forward Characteristics**

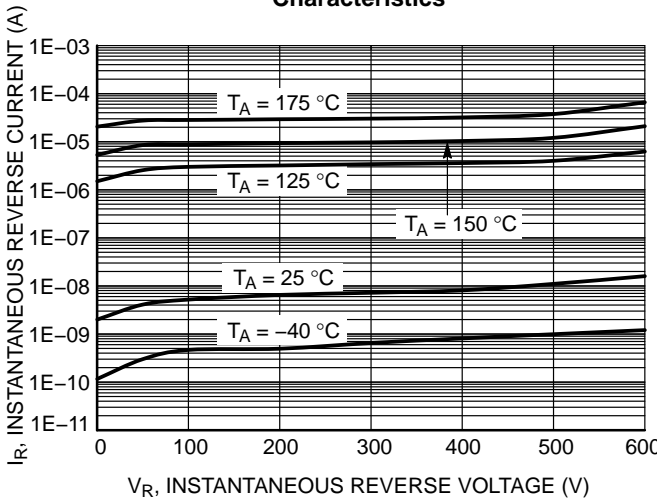

**Figure 3. Typical Reverse Characteristics**

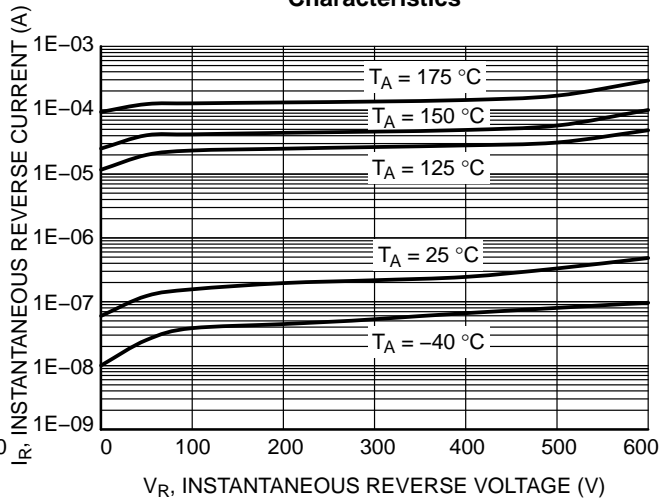

**Figure 4. Maximum Reverse Characteristics**

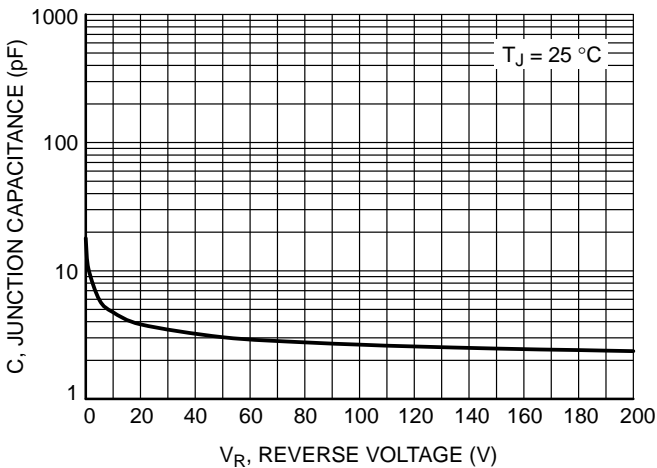

**Figure 5. Typical Junction Capacitance**

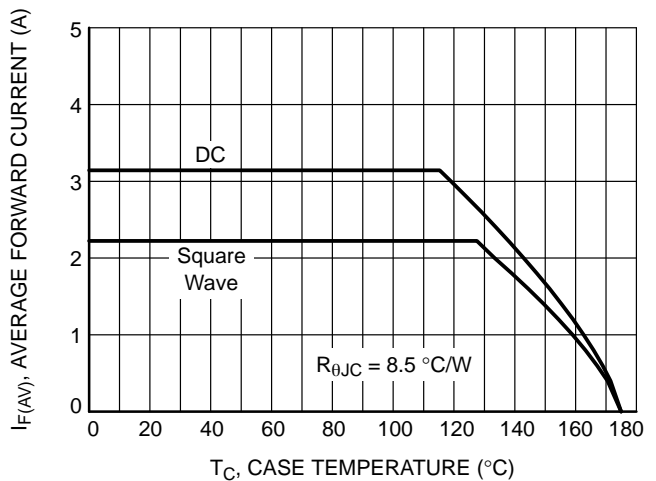

**Figure 6. Current Derating**

# NHPM260T3G, NRVHPM260T3G

## TYPICAL CHARACTERISTICS

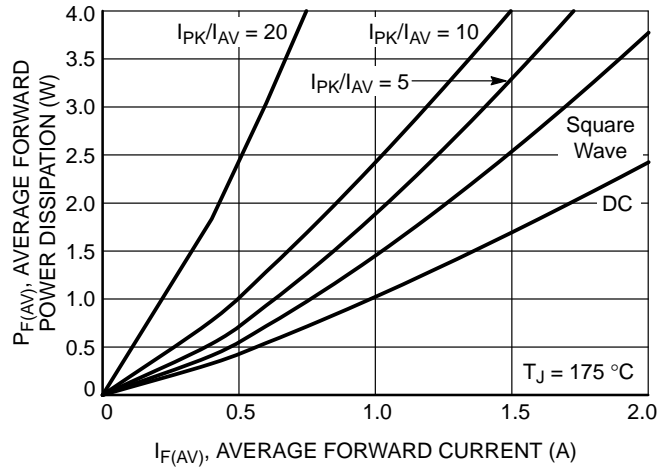

Figure 7. Forward Power Dissipation

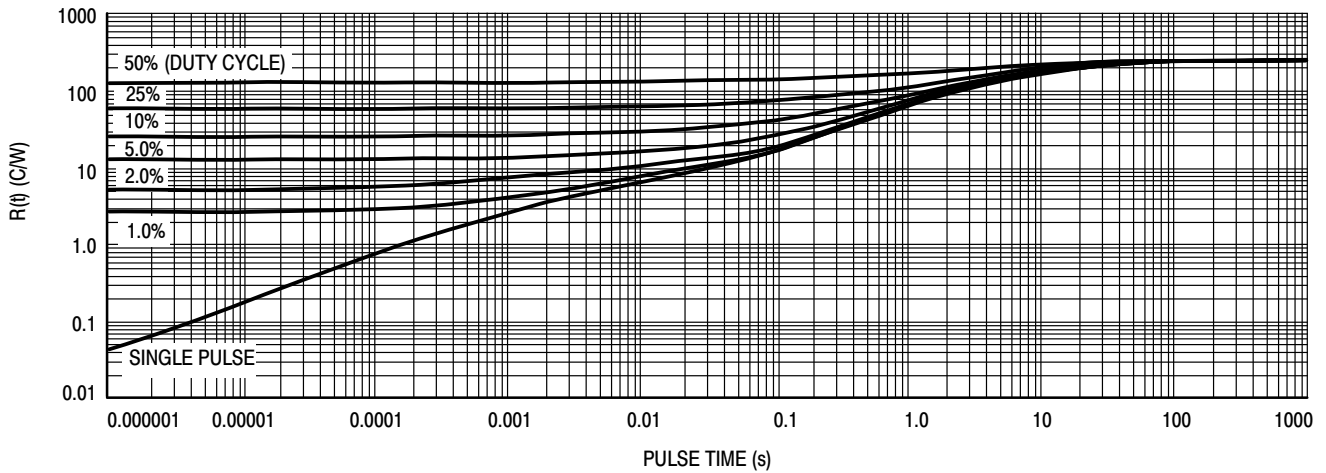

Figure 8. Thermal Response, Junction-to-Ambient (20 mm<sup>2</sup> pad)

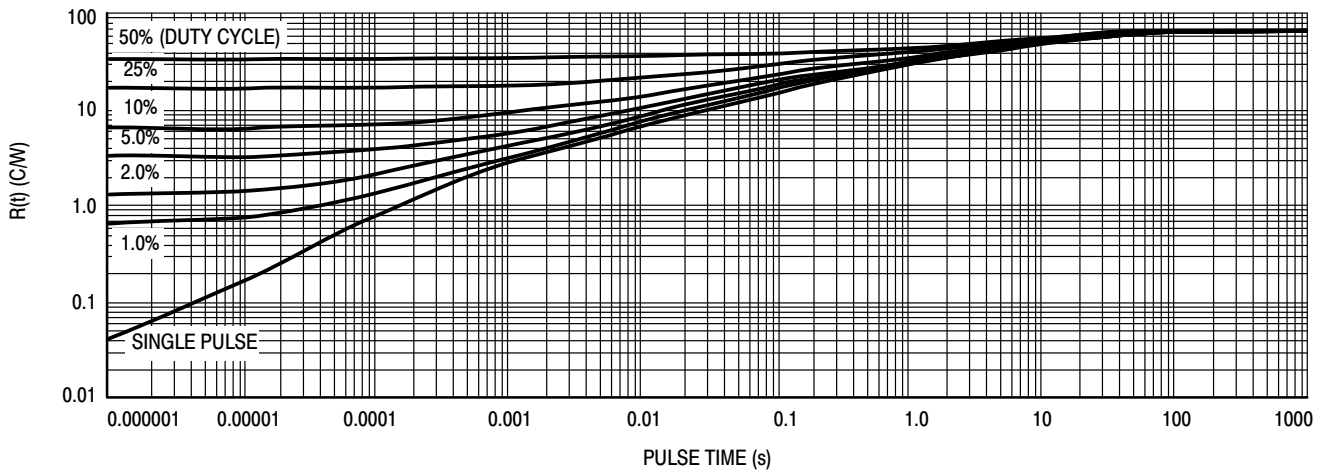

Figure 9. Thermal Response, Junction-to-Ambient (1 in<sup>2</sup> pad)

# NHPM260T3G, NRVHPM260T3G

## REVISION HISTORY

Revision	Description of Changes	Date
2	Rebranded the document to <b>onsemi</b> format. NHPM260T3G OPN marked as Discontinued.	2/9/2026

This document has undergone updates prior to the inclusion of this revision history table. The changes tracked here only reflect updates made on the noted approval dates.



**POWERMITE 1.90x1.96x1.00**  
**CASE 457**  
**ISSUE H**

DATE 16 MAY 2025

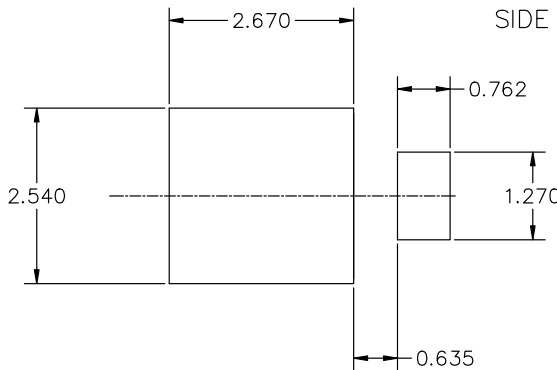
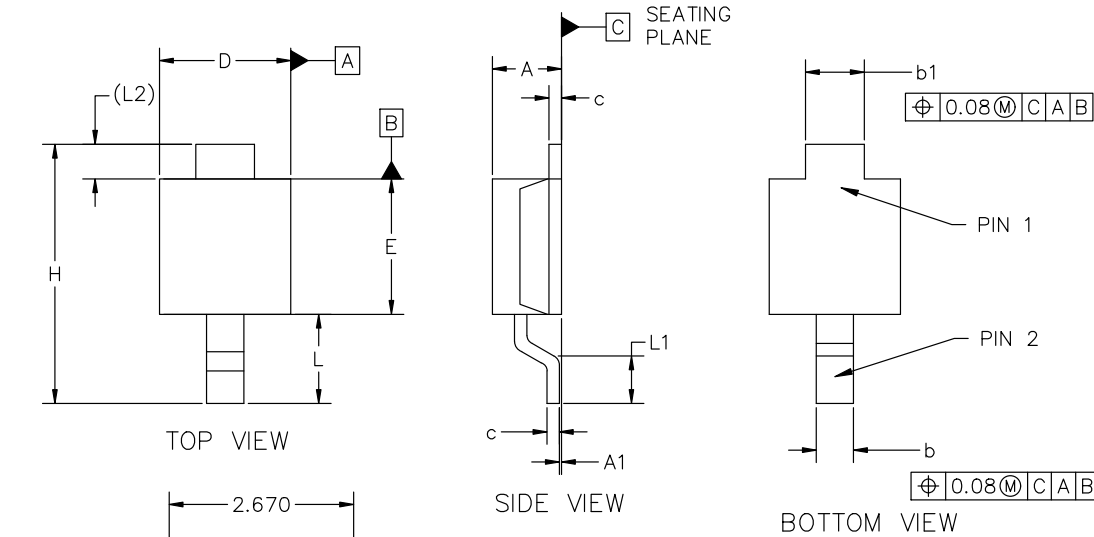

**RECOMMENDED MOUNTING FOOTPRINT**

\*For additional information on our Pb-Free Strategy and Soldering and Mounting Techniques Reference Manual, SOLDERRM/D.

MILLIMETERS			
DIM	MIN	NOM	MAX
A	0.85	1.00	1.15
A1	0.00	0.05	0.10
b	0.40	0.55	0.69
b1	0.70	0.85	1.00
c	0.10	0.18	0.25
D	1.75	1.90	2.05
E	1.75	1.96	2.18
H	3.60	3.75	3.90
L	1.20	1.35	1.50
L1	0.50	0.65	0.80
L2	0.50 REF		

- NOTES:
- DIMENSIONING AND TOLERANCING AS PER ASME Y14.5M, 2018.
  - CONTROLLING DIMENSION: MILLIMETERS.
  - DIMENSION D & E DO NOT INCLUDE MOLD FLASH, PROTRUSIONS OR GATE BURRS.

**GENERIC MARKING DIAGRAMS\***

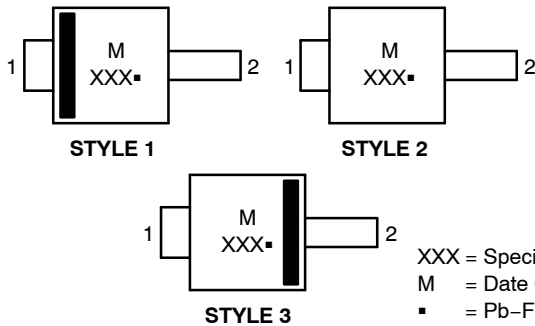

STYLE 1:  
PIN 1. CATHODE  
2. ANODE

STYLE 2:  
PIN 1. ANODE OR CATHODE  
2. CATHODE OR ANODE (BI-DIRECTIONAL)

STYLE 3:  
PIN 1. ANODE  
2. CATHODE

XXX = Specific Device Code  
M = Date Code  
▪ = Pb-Free Package

\*This information is generic. Please refer to device data sheet for actual part marking. Pb-Free indicator, "G" or microdot "▪", may or may not be present. Some products may not follow the Generic Marking.

<b>DOCUMENT NUMBER:</b>	<b>98ASB14853C</b>	Electronic versions are uncontrolled except when accessed directly from the Document Repository. Printed versions are uncontrolled except when stamped "CONTROLLED COPY" in red.
<b>DESCRIPTION:</b>	<b>POWERMITE 1.90x1.96x1.00</b>	<b>PAGE 1 OF 1</b>

onsemi and onsemi are trademarks of Semiconductor Components Industries, LLC dba onsemi or its subsidiaries in the United States and/or other countries. onsemi reserves the right to make changes without further notice to any products herein. onsemi makes no warranty, representation or guarantee regarding the suitability of its products for any particular purpose, nor does onsemi assume any liability arising out of the application or use of any product or circuit, and specifically disclaims any and all liability, including without limitation special, consequential or incidental damages. onsemi does not convey any license under its patent rights nor the rights of others.

**onsemi**, **Onsemi**, and other names, marks, and brands are registered and/or common law trademarks of Semiconductor Components Industries, LLC dba "**onsemi**" or its affiliates and/or subsidiaries in the United States and/or other countries. **onsemi** owns the rights to a number of patents, trademarks, copyrights, trade secrets, and other intellectual property. A listing of **onsemi**'s product/patent coverage may be accessed at [www.onsemi.com/site/pdf/Patent-Marking.pdf](http://www.onsemi.com/site/pdf/Patent-Marking.pdf). **onsemi** reserves the right to make changes at any time to any products or information herein, without notice. The information herein is provided "as-is" and **onsemi** makes no warranty, representation or guarantee regarding the accuracy of the information, product features, availability, functionality, or suitability of its products for any particular purpose, nor does **onsemi** assume any liability arising out of the application or use of any product or circuit, and specifically disclaims any and all liability, including without limitation special, consequential or incidental damages. Buyer is responsible for its products and applications using **onsemi** products, including compliance with all laws, regulations and safety requirements or standards, regardless of any support or applications information provided by **onsemi**. "Typical" parameters which may be provided in **onsemi** data sheets and/or specifications can and do vary in different applications and actual performance may vary over time. All operating parameters, including "Typicals" must be validated for each customer application by customer's technical experts. **onsemi** does not convey any license under any of its intellectual property rights nor the rights of others. **onsemi** products are not designed, intended, or authorized for use as a critical component in life support systems or any FDA Class 3 medical devices or medical devices with a same or similar classification in a foreign jurisdiction or any devices intended for implantation in the human body. Should Buyer purchase or use **onsemi** products for any such unintended or unauthorized application, Buyer shall indemnify and hold **onsemi** and its officers, employees, subsidiaries, affiliates, and distributors harmless against all claims, costs, damages, and expenses, and reasonable attorney fees arising out of, directly or indirectly, any claim of personal injury or death associated with such unintended or unauthorized use, even if such claim alleges that **onsemi** was negligent regarding the design or manufacture of the part. **onsemi** is an Equal Opportunity/Affirmative Action Employer. This literature is subject to all applicable copyright laws and is not for resale in any manner.

## ADDITIONAL INFORMATION

### TECHNICAL PUBLICATIONS:

Technical Library: [www.onsemi.com/design/resources/technical-documentation](http://www.onsemi.com/design/resources/technical-documentation)  
onsemi Website: [www.onsemi.com](http://www.onsemi.com)

### ONLINE SUPPORT: [www.onsemi.com/support](http://www.onsemi.com/support)

For additional information, please contact your local Sales Representative at [www.onsemi.com/support/sales](http://www.onsemi.com/support/sales)