

Intelligent Power Module (IPM) 600 V, 10 A

NFAQ1060L36TB

The NFAQ1060L36TB is a fully-integrated inverter power stage consisting of a high-voltage driver, six IGBT's and a thermistor, suitable for driving permanent magnet synchronous motors (PMSM), brushless-DC (BLDC) motors and AC asynchronous motors. The IGBT's are configured in a 3-phase bridge with separate emitter connections for the lower legs for maximum flexibility in the choice of control algorithm. The power stage has a full range of protection functions including cross-conduction protection, external shutdown and under-voltage lockout functions. An internal comparator and reference connected to the over-current protection circuit allows the designer to set the over-current protection level.

Features

- Three-phase 10 A / 600 V IGBT Module with Integrated Drivers
- Compact 29.6 mm x 18.2 mm Dual In-Line Package
- Built-in Under Voltage Protection
- Cross-conduction Protection
- ITRIP Input to Shut Down All IGBT's
- Integrated Bootstrap Diodes and Resistors
- Thermistor for Substrate Temperature Measurement
- Shut Down Pin
- UL1557 Certification (File Number: E339285)

Typical Applications

- Industrial Pumps
- Industrial Fans
- Industrial Automation
- Home Appliances

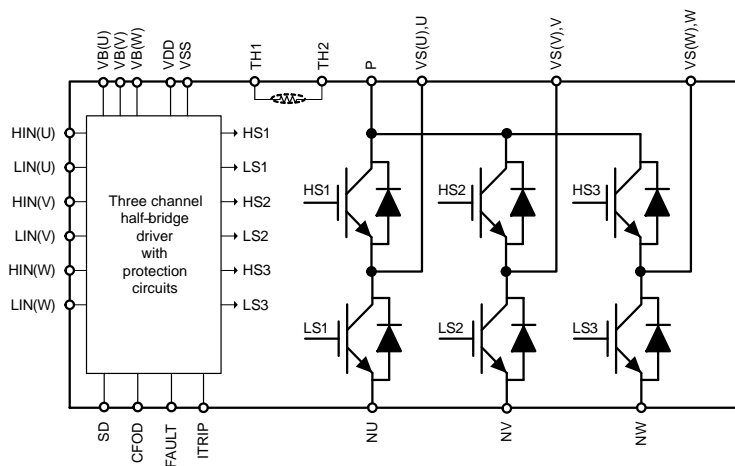
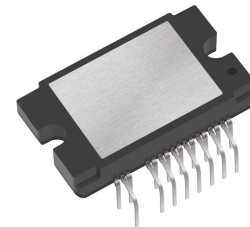

Figure 1. Function Diagram



ON Semiconductor®

www.onsemi.com



DIP38 29.6x18.2
CASE 125BS

MARKING DIAGRAM

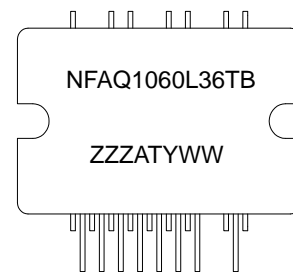

NFAQ1060L36TB = Specific Device Code
 ZZZ = Assembly Lot Code
 A = Assembly Location
 T = Test Location
 Y = Year
 WW = Work Week
 Device marking is on package top side

ORDERING INFORMATION

Device	Package	Shipping (Qty / Packing)
NFAQ1060L36TB	DIP38 (Pb-Free)	400 / Tube

NFAQ1060L36TB

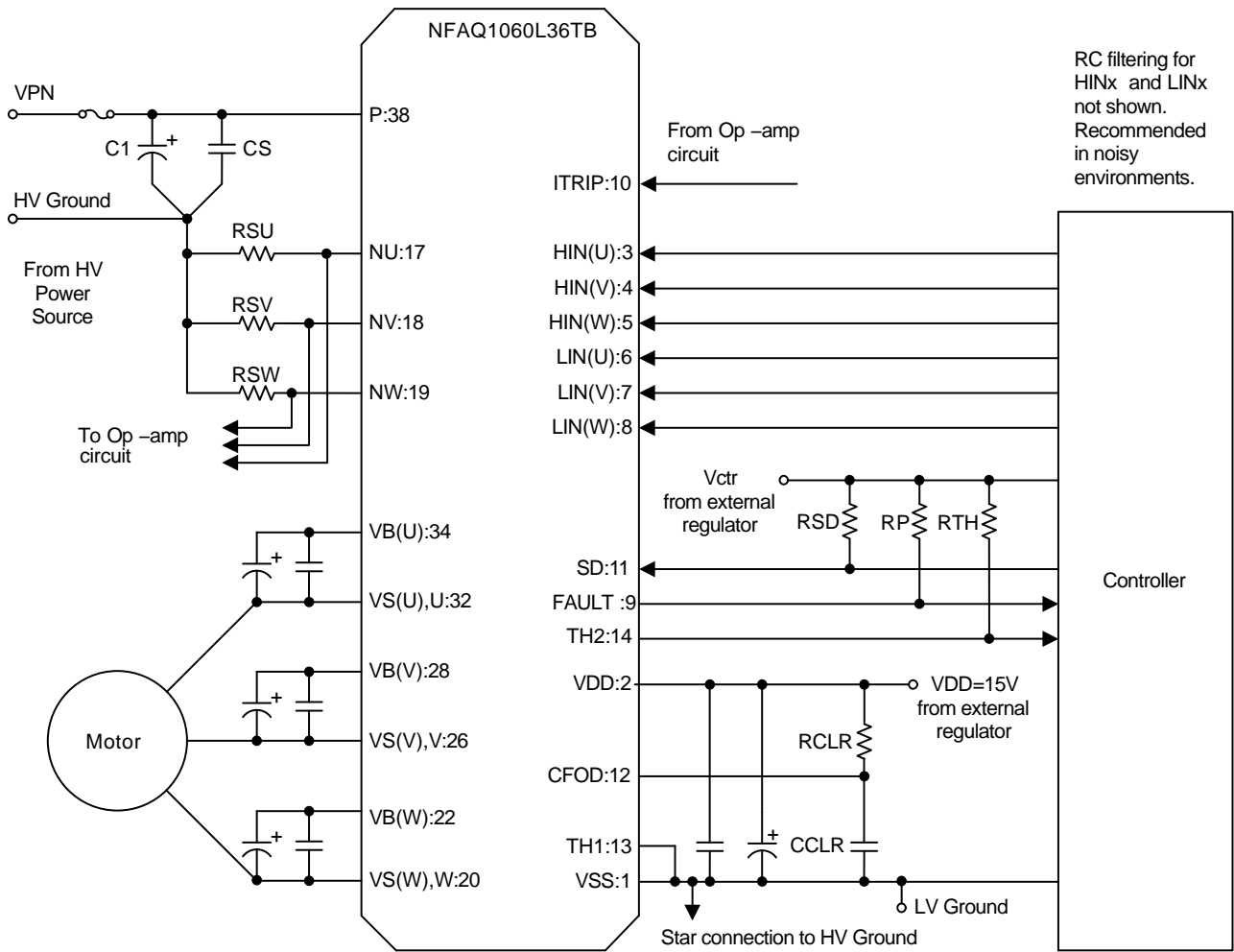

Figure 2. Application Schematic

NFAQ1060L36TB

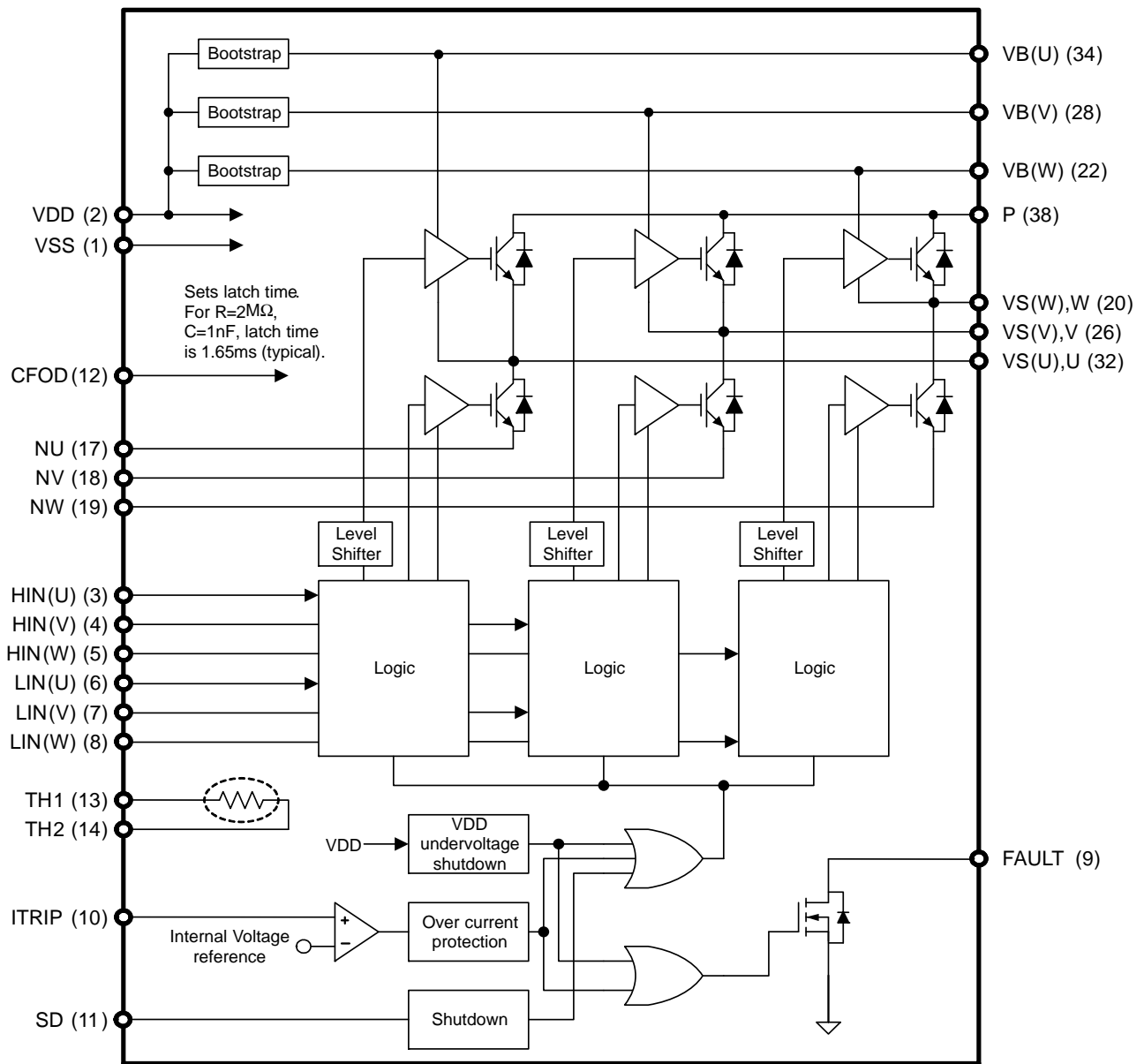

Figure 3. Simplified Block Diagram

NFAQ1060L36TB

Table 1. PIN FUNCTION DESCRIPTION

Pin	Name	Description
1	VSS	Low-Side Common Supply Ground
2	VDD	Low-Side Bias Voltage for IC and IGBTs Driving
3	HIN(U)	Signal Input for High-Side U Phase
4	HIN(V)	Signal Input for High-Side V Phase
5	HIN(W)	Signal Input for High-Side W Phase
6	LIN(U)	Signal Input for Low-Side U Phase
7	LIN(V)	Signal Input for Low-Side V Phase
8	LIN(W)	Signal Input for Low-Side W Phase
9	FAULT	Fault output
10	ITRIP	Input for Over Current Protection
11	SD	Shut Down Input
12	CFOD	Capacitor and Resistor for Fault Output Duration Selection
13	TH1	Thermistor Bias Voltage
14	TH2	Series Resistor for Thermistor
17	NU	Negative DC-Link Input for U Phase
18	NV	Negative DC-Link Input for V Phase
19	NW	Negative DC-Link Input for W Phase
20	VS(W), W	High-Side Bias Voltage GND for W phase IGBT Driving, Output for W Phase
22	VB(W)	High-Side Bias Voltage for W phase IGBT Driving
26	VS(V), V	High-Side Bias Voltage GND for V phase IGBT Driving, Output for V Phase
28	VB(V)	High-Side Bias Voltage for V phase IGBT Driving
32	VS(U), U	High-Side Bias Voltage GND for U phase IGBT Driving, Output for U Phase
34	VB(U)	High-Side Bias Voltage for U phase IGBT Driving
38	P	Positive DC-Link Input

NOTE: Pins 15, 16, 21, 23, 24, 25, 27, 29, 30, 31, 33, 35, 36 and 37 are not present

NFAQ1060L36TB

Table 2. ABSOLUTE MAXIMUM RATINGS at $T_C = 25^\circ\text{C}$ (Note 1)

Parameter	Symbol	Conditions	Rating	Unit
Supply Voltage	VPN	P-NU, NV, NW, VPN (surge) < 500 V (Note 2)	450	V
Collector – Emitter Voltage	VCES	P-U, V, W; U-NU; V-NV; W-NW	600	V
Each IGBT Collector Current	IC	P, U, V, W, NU, NV, NW terminal current	± 10	A
		P, U, V, W, NU, NV, NW terminal current, $T_c = 100^\circ\text{C}$	± 5	A
Each IGBT Collector Current (Peak)	ICp	$T_c = 25^\circ\text{C}$, Under 1 ms Pulse Width	± 20	A
Corrector Dissipation	Pc	$T_c = 25^\circ\text{C}$, Per One Chip	46	W
High-Side Control Bias voltage	VBS	VB(U)–VS(U), VB(V)–VS(V), VB(W)–VS(W) (Note 3)	–0.3 to +20.0	V
Control Supply Voltage	VDD	VDD–VSS	–0.3 to +20.0	V
Input Signal Voltage	VIN	HIN(U), HIN(V), HIN(W), LIN(U), LIN(V), LIN(W) – VSS	–0.3 to V_{DD}	V
FAULT Terminal Voltage	VFAULT	FAULT–VSS	–0.3 to V_{DD}	V
CFOD Terminal Voltage	VCFOD	CFOD–VSS	–0.3 to V_{DD}	V
SD Terminal Voltage	VSD	SD–VSS	–0.3 to V_{DD}	V
Current Sensing Input Voltage	VITRIP	ITRIP–VSS	–0.3 to +10.0	V
Operating Junction Temperature	T_j		150	$^\circ\text{C}$
Storage Temperature	T_{stg}		–40 to +125	$^\circ\text{C}$
Module Case Operation Temperature	T_c		–40 to +125	$^\circ\text{C}$
Tightening Torque	MT	Case mounting screws	0.6	Nm
Isolation Voltage	Viso	50 Hz sine wave AC 1 minute (Note 4)	2000	Vrms

Stresses exceeding those listed in the Maximum Ratings table may damage the device. If any of these limits are exceeded, device functionality should not be assumed, damage may occur and reliability may be affected.

1. Refer to ELECTRICAL CHARACTERISTICS, RECOMMENDED OPERATING RANGES and/or APPLICATION INFORMATION for Safe Operating parameters
2. This surge voltage developed by the switching operation due to the wiring inductance between P and NU, NV, NW terminal.
3. $VBS = VB(U) - VS(U)$, $VB(V) - VS(V)$, $VB(W) - VS(W)$
4. Test conditions : AC2500V, 1 s

Table 3. RECOMMENDED OPERATING RANGES

Rating	Symbol	Conditions	Min	Typ	Max	Unit
Supply Voltage	VPN	P – NU, NV, NW	0	280	450	V
High-Side Control Bias Voltage	VBS	VB(U) – VS(U), VB(V) – VS(V), VB(W) – VS(W)	13.0	15	17.5	V
Control Supply Voltage	VDD	VDD – VSS	14.0	15	16.5	V
ON-state Input Voltage	VIN(ON)	HIN(U), HIN(V), HIN(W), LIN(U), LIN(V), LIN(W) – VSS	3.0	–	5.0	V
OFF-state Input Voltage	VIN(OFF)		0	–	0.3	V
PWM Frequency	fPWM		1	–	20	kHz
Dead Time	DT	Turn-off to Turn-on (external)	1	–	–	μs
Allowable Input Pulse Width	PWIN	ON and OFF	1	–	–	μs
Tightening Torque		'M3' Type Screw	0.4	–	0.6	Nm

Functional operation above the stresses listed in the Recommended Operating Ranges is not implied. Extended exposure to stresses beyond the Recommended Operating Ranges limits may affect device reliability.

NFAQ1060L36TB

Table 4. ELECTRICAL CHARACTERISTICS at $T_C = 25\text{ }^\circ\text{C}$, V_{BIAS} (VBS, VDD) = 15 V unless otherwise noted.

Parameter	Test Conditions	Symbol	Min	Typ	Max	Unit
Power Output Section						
Collector–Emitter Leakage Current	$V_{CE} = 600\text{ V}$	ICES	–	–	100	μA
Collector–Emitter Saturation Voltage	$I_N = 5\text{ A}$, $I_C = 10\text{ A}$, $T_j = 25\text{ }^\circ\text{C}$	VCE(sat)	–	1.9	2.5	V
	$I_N = 5\text{ A}$, $I_C = 5\text{ A}$, $T_j = 100\text{ }^\circ\text{C}$		–	1.5	–	V
FWDi Forward Voltage	$I_N = 0\text{ V}$, $I_C = -10\text{ A}$, $T_j = 25\text{ }^\circ\text{C}$	VF	–	2.0	2.4	V
	$I_N = 0\text{ V}$, $I_C = -5\text{ A}$, $T_j = 100\text{ }^\circ\text{C}$		–	1.55	–	V
Junction to Case Thermal Resistance	Inverter IGBT Part (per 1/6 Module)	Rth(j–c)Q	–	–	2.7	$^\circ\text{C/W}$
	Inverter FRD Part (per 1/6 Module)	Rth(j–c)F	–	–	7.3	$^\circ\text{C/W}$
Switching Character						
Switching Time	$I_C = 10\text{ A}$, $V_{PN} = 300\text{ V}$, $T_j = 25\text{ }^\circ\text{C}$, Inductive Switching	t_{ON}	–	0.5	1.1	μs
		t_{OFF}	–	0.6	1.3	μs
Turn–on Switching Loss	$I_C = 10\text{ A}$, $V_{PN} = 300\text{ V}$, $T_j = 25\text{ }^\circ\text{C}$	E_{ON}	–	280	–	μJ
Turn–off Switching Loss		E_{OFF}	–	130	–	μJ
Total Switching Loss		E_{TOT}	–	410	–	μJ
Turn–on Switching Loss	$I_C = 5\text{ A}$, $V_{PN} = 300\text{ V}$, $T_j = 100\text{ }^\circ\text{C}$	E_{ON}	–	150	–	μJ
Turn–off Switching Loss		E_{OFF}	–	90	–	μJ
Total Switching Loss		E_{TOT}	–	240	–	μJ
Diode Reverse Recovery Energy	$I_C = 5\text{ A}$, $V_{PN} = 300\text{ V}$, $T_j = 100\text{ }^\circ\text{C}$, (di/dt set by internal driver)	E_{REC}	–	70	–	μJ
Diode Reverse Recovery Time		t_{RR}	–	200	–	ns
Reverse Bias Safe Operating Area	$I_C = 20\text{ A}$, $V_{CE} = 450\text{ V}$	RBSOA	Full Square			
Short Circuit Safe Operating Area	$V_{CE} = 400\text{ V}$, $T_j = 100\text{ }^\circ\text{C}$	SCSOA	4	–	–	μs
Driver Section						
Quiescent VBS Supply Current	$V_{BS} = 15\text{ V}$, $I_{IN} = 0\text{ V}$, per driver	IQBS	–	0.07	0.4	mA
Quiescent VDD Supply Current	$V_{DD} = 15\text{ V}$, $I_{IN} = 0\text{ V}$, $V_{DD} - V_{SS}$	IQDD	–	0.95	3.0	mA
ON Threshold Voltage	$I_{IN}(U)$, $I_{IN}(V)$, $I_{IN}(W)$, $I_{IN}(U)$, $I_{IN}(V)$, $I_{IN}(W) - V_{SS}$	VIN(ON)	–	–	2.5	V
OFF Threshold Voltage		VIN(OFF)	0.8	–	–	V
Logic 1 Input Current	$I_{IN} = +3.3\text{ V}$	IIN+	–	660	900	μA
Logic 0 Input Current	$I_{IN} = 0\text{ V}$	IIN–	–	–	3	μA
Bootstrap ON Resistance	$I_B = 1\text{ mA}$	RB	–	500	–	Ω
FAULT Terminal Sink Current	FAULT: ON / VFAULT = 0.1 V	IoSD	–	2	–	mA
Fault–Output Pulse Width	FAULT–VSS	tFOD	1.1	1.65	2.2	ms
CFOD Threshold	CFOD–VSS	VCFOF	–	8	–	V
Shut Down Threshold	SD–VSS	VSD+	–	–	2.5	V
		VSD–	0.8	–	–	V
ITRIP Trip Level	ITRIP–VSS	VITRIP	0.44	0.49	0.54	V
ITRIP to Shutdown Propagation Delay		tITRIP	–	1.1	–	μs
ITRIP Blanking Time		tITRIPBL	250	350	–	ns
High–Side Control Bias Voltage Under–Voltage Protection	Reset Level	UVBSR	10.3	11.1	11.9	V
	Detection Level	UVBSD	10.1	10.9	11.7	V
	Hysteresis	UVBSH	–	0.2	–	V
Supply Voltage Under–Voltage Protection	Reset Level	UVDDR	10.3	11.1	11.7	V
	Detection Level	UVDDD	10.1	10.9	11.5	V
	Hysteresis	UVDDH	–	0.2	–	V

Product parametric performance is indicated in the Electrical Characteristics for the listed test conditions, unless otherwise noted. Product performance may not be indicated by the Electrical Characteristics if operated under different conditions.

NFAQ1060L36TB

TYPICAL CHARACTERISTICS

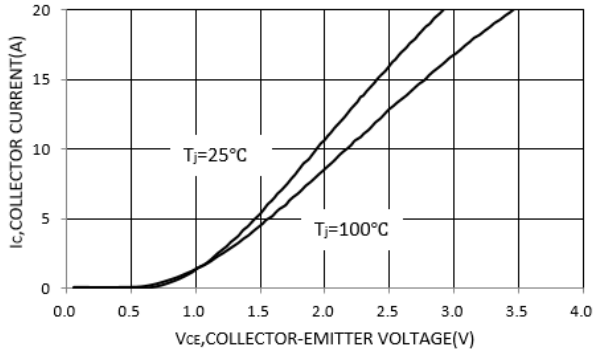

Figure 4. V_{CE} versus I_C for Different Temperatures ($V_{DD} = 15\text{ V}$)

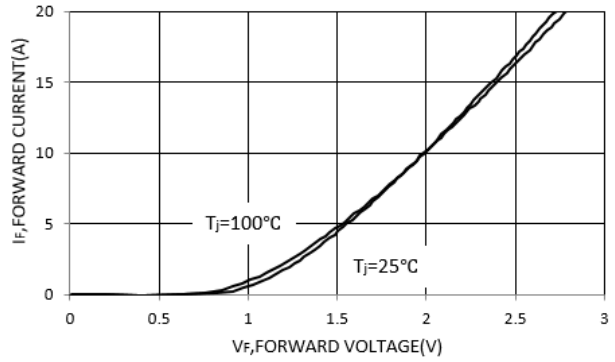

Figure 5. V_F versus I_F for Different Temperatures

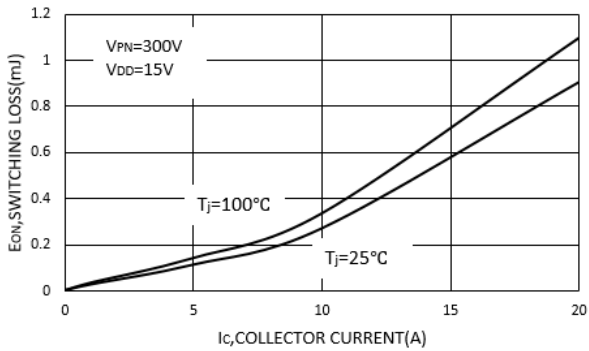

Figure 6. E_{ON} versus I_C for Different Temperatures

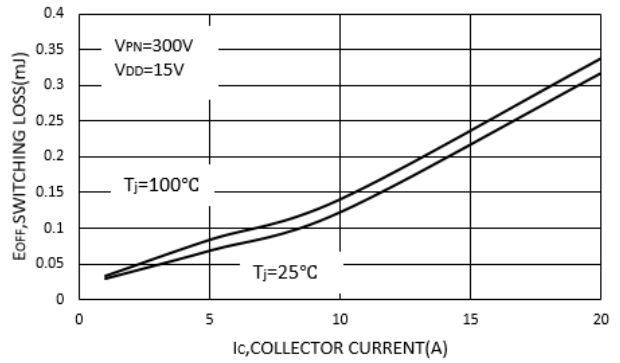

Figure 7. E_{OFF} versus I_C for Different Temperatures

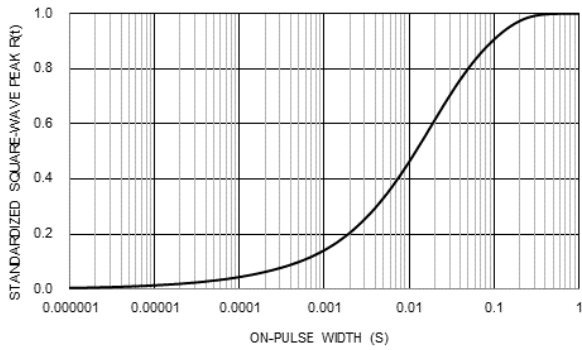

Figure 8. Thermal Impedance Plot (IGBT)

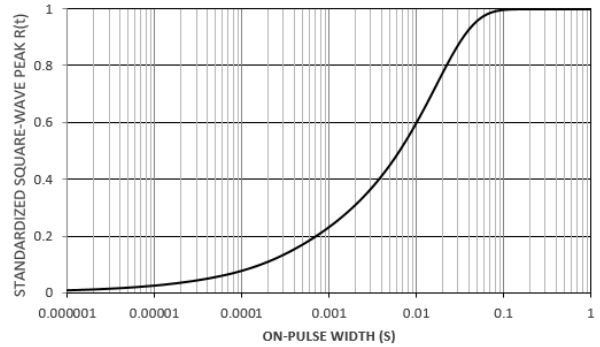

Figure 9. Thermal Impedance Plot (FRD)

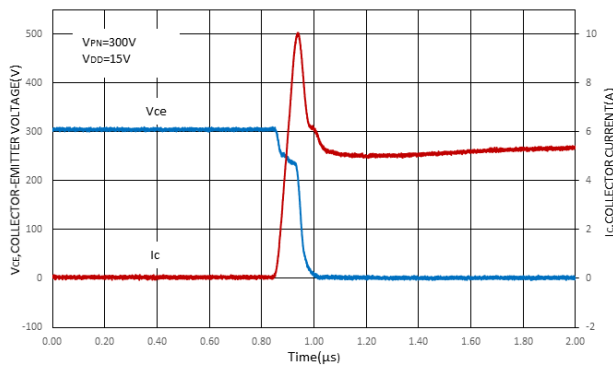

Figure 10. Turn-on Waveform $T_j = 100^\circ\text{C}$, $V_{CC} = 300\text{ V}$

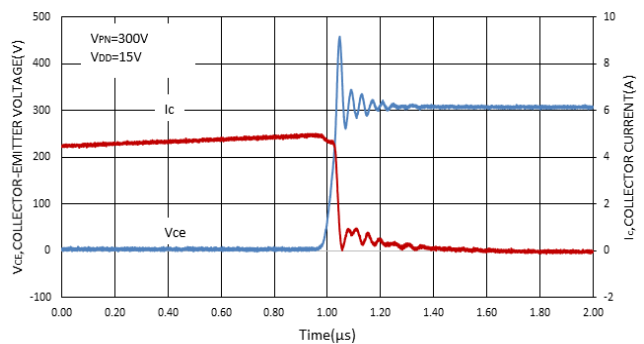
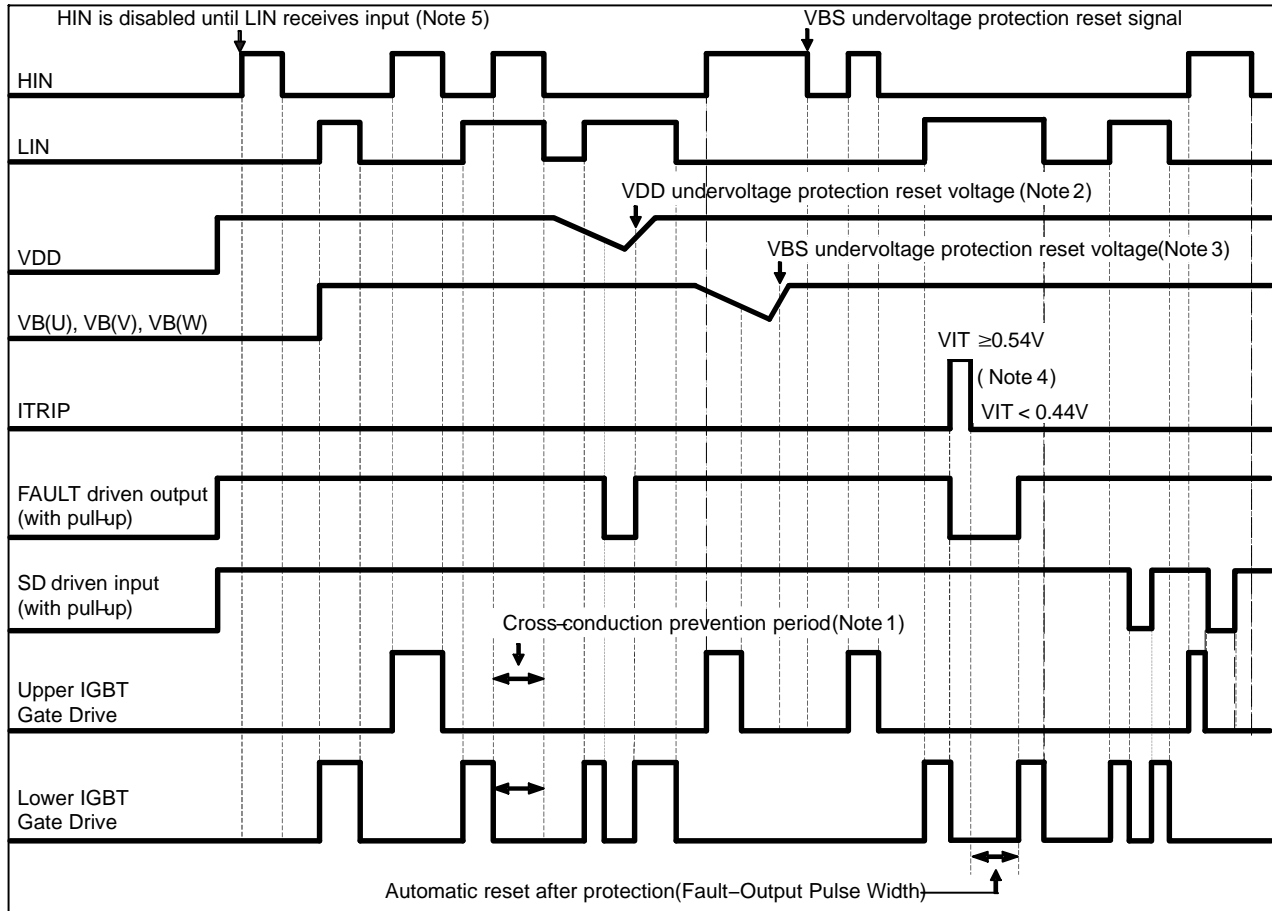

Figure 11. Turn-off Waveform $T_j = 100^\circ\text{C}$, $V_{CC} = 300\text{ V}$

APPLICATIONS INFORMATION

Input / Output Timing Chart



NOTES:

1. This section of the timing diagram shows the effect of cross-conduction prevention.
2. This section of the timing diagram shows that when the voltage on VDD decreases sufficiently all gate output signals will go low, switching off all six IGBTs. When the voltage on VDD rises sufficiently, normal operation will resume.
3. This section shows that when the bootstrap voltage on VB(U) (VB(V), VB(W)) drops, the corresponding high side output U (V, W) is switched off. When the voltage on VB(U) (VB(V), VB(W)) rises sufficiently, normal operation will resume.
4. This section shows that when the voltage on ITRIP exceeds the threshold, all IGBTs are turned off. Normal operation resumes later after the over-current condition is removed.
5. After VDD has risen above the threshold to enable normal operation, the driver waits to receive an input signal on the LIN input before enabling the driver for the HIN signal.

Figure 12. Input / Output Timing Chart

Table 5. INPUT / OUTPUT LOGIC TABLE

INPUT				OUTPUT			
HIN	LIN	ITRIP	SD	High side IGBT	Low side IGBT	U,V,W	FAULT
H	L	L	H	ON (Note 5)	OFF	P	OFF
L	H	L	H	OFF	ON	NU,NV,NW	OFF
L	L	L	H	OFF	OFF	High Impedance	OFF
H	H	L	H	OFF	OFF	High Impedance	OFF
X	X	H	X	OFF	OFF	High Impedance	ON
X	X	L	L	OFF	OFF	High Impedance	OFF

Table 6. THERMISTOR CHARACTERISTICS

Parameter	Symbol	Condition	Min	Typ	Max	Unit
Resistance	R ₂₅	T _{th} = 25°C	99	100	101	kΩ
	R ₁₀₀	T _{th} = 100°C	5.18	5.38	5.60	kΩ
B-Constant (25 to 50°C)	B		4208	4250	4293	K
Temperature Range			-40	-	+125	°C

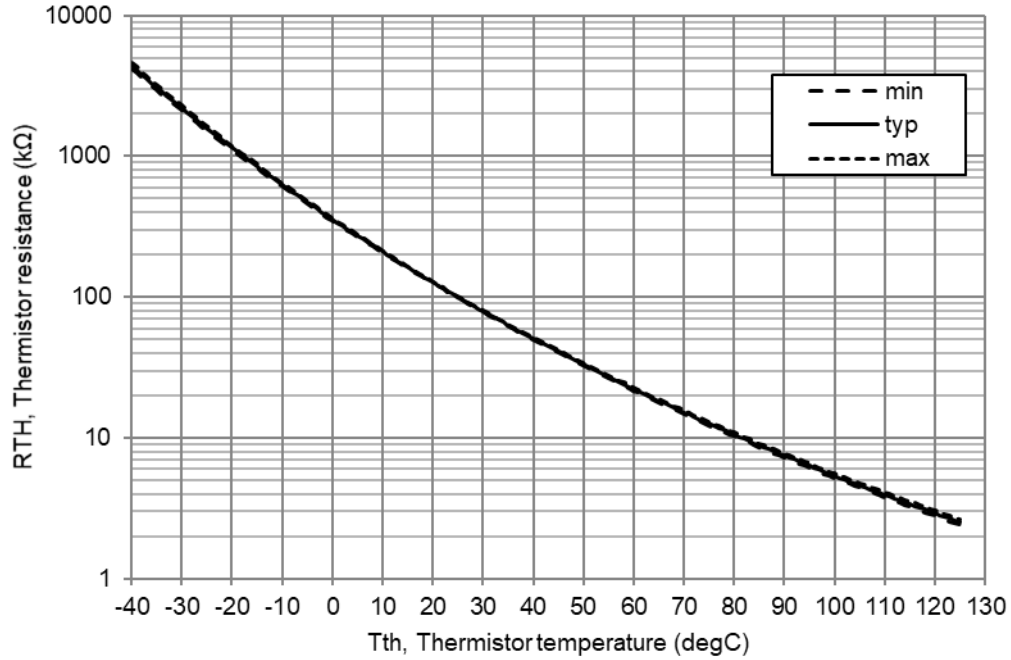

Figure 13. Thermistor Resistance versus Thermistor Temperature

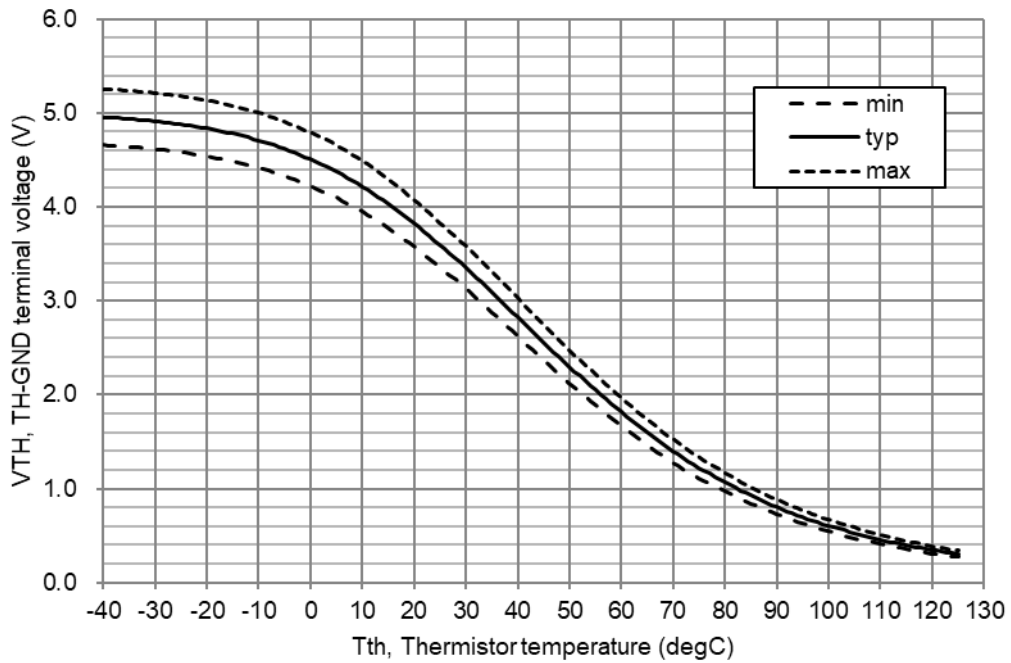

Figure 14. Thermistor Voltage versus Thermistor Temperature
Conditions: R_{TH} = 39 kΩ, Pull-up Voltage 5.0 V (see Figure 2)

FAULT Pin

The FAULT output is an open drain output requiring a pull-up resistor. If the pull-up voltage is 5 V, use a pull-up resistor with a value of 6.8 kΩ or higher. If the pull-up voltage is 15 V, use a pull-up resistor with a value of 20 kΩ or higher. The FAULT output is triggered if there is a VDD undervoltage or an overcurrent condition.

Under-voltage Protection

If VDD goes below the VDD supply under-voltage lockout falling threshold, the FAULT output is switched on. The FAULT output stays on until VDD rises above the VDD supply under-voltage lockout rising threshold. After VDD has risen above the threshold to enable normal operation, the driver waits to receive an input signal on the LIN input before enabling the driver for the HIN signal.

Overcurrent Protection

An over-current condition is detected if the voltage on the ITRIP pin is larger than the reference voltage. There is a blanking time of typically 350 ns to improve noise immunity. After a shutdown propagation delay of typically 1.1 μs, the FAULT output is switched on. The FAULT output is held on for a time determined by the resistor and capacitor connected to the CFOD pin. If RCLR = 2 MΩ and CCLR = 1 nF, the FAULT output is switched on for 1.65 ms (typ.) because the FAULT pin goes back to high impedance when CFOD is higher than 8 V (typ.).

The over-current protection threshold should be set to be equal or lower to 2 times the module rated current (Io).

An additional fuse is recommended to protect against system level or abnormal over-current fault conditions.

Capacitors on High Voltage and VDD Supplies

Both the high voltage and VDD supplies require an electrolytic capacitor and an additional high frequency capacitor. The recommended value of the high frequency capacitor is between 100 nF and 10 μF.

SD Pin

The SD terminal pin is used to enable or shut down the built-in driver. If the voltage on the SD pin rises above the VSD+ voltage, the output drivers are enabled. If the voltage on the SD pin falls below the VSD- voltage, the drivers are disabled.

Minimum Input Pulse Width

When input pulse width is less than 1 μs, an output may not react to the pulse. (Both ON signal and OFF signal)

Calculation of Bootstrap Capacitor Value

The bootstrap capacitor value CB is calculated using the following approach. The following parameters influence the choice of bootstrap capacitor:

- VBS: Bootstrap power supply.
15 V is recommended.
- QG: Total gate charge of IGBT at VBS = 15 V.
17 nC
- UVLO: Falling threshold for UVLO.
Specified as 12 V.
- IDMAX: High side drive power dissipation.
Specified as 0.4 mA
- TONMAX: Maximum ON pulse width of high side IGBT.

Capacitance calculation formula:

$$CB = (QG + IDMAX * TONMAX)/(VBS - UVLO)$$

CB is recommended to be approximately 3 times the value calculated above. The recommended value of CB is in the range of 1 to 47 μF, however, the value needs to be verified prior to production. When not using the bootstrap circuit, each high side driver power supply requires an external independent power supply.

The internal bootstrap circuit uses a MOSFET. The turn on time of this MOSFET is synchronized with the turn on of the low side IGBT. The bootstrap capacitor is charged by turning on the low side IGBT.

If the low side IGBT is held on for a long period of time (more than one second for example), the bootstrap voltage on the high side MOSFET will slowly discharge.

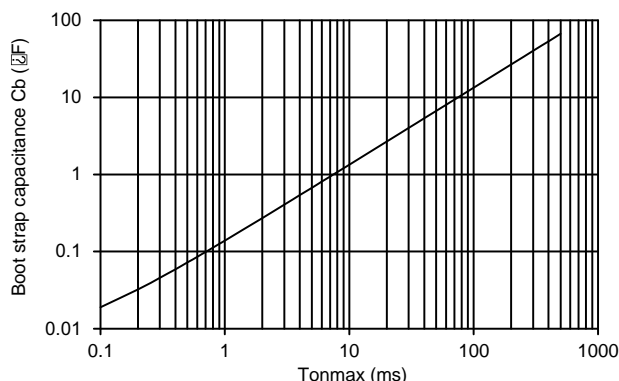

Figure 15. Bootstrap Capacitance versus Tonmax

NFAQ1060L36TB

TEST CIRCUITS

- ICES

	U+	V+	W+	U-	V-	W-
A	38	38	38	32	26	20
B	32	26	20	17	18	19

U+, V+, W+ : High side phase

U-, V-, W- : Low side phase

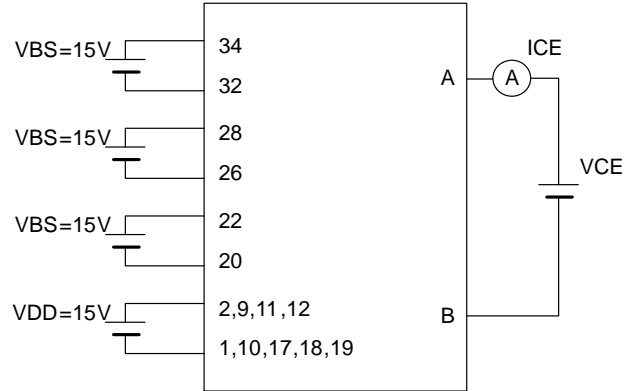

Figure 16. Test Circuit for I_{CE}

- $V_{CE(sat)}$ (Test by pulse)

	U+	V+	W+	U-	V-	W-
A	38	38	38	32	26	20
B	32	26	20	17	18	19
C	3	4	5	6	7	8

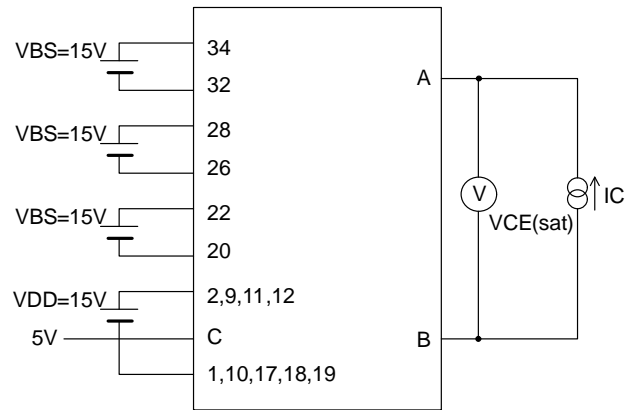

Figure 17. Test Circuit for $V_{CE(sat)}$

- V_F (Test by pulse)

	U+	V+	W+	U-	V-	W-
A	38	38	38	32	26	20
B	32	26	20	17	18	19

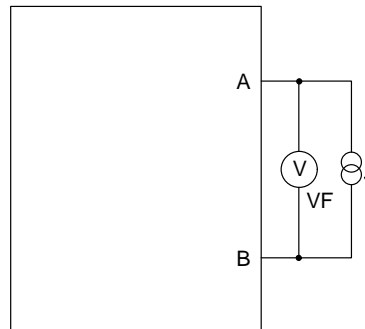

Figure 18. Test Circuit for V_F

NFAQ1060L36TB

- RB (Test by pulse)

	U+	V+	W+
A	2	2	2
B	34	28	22
C	6	7	8

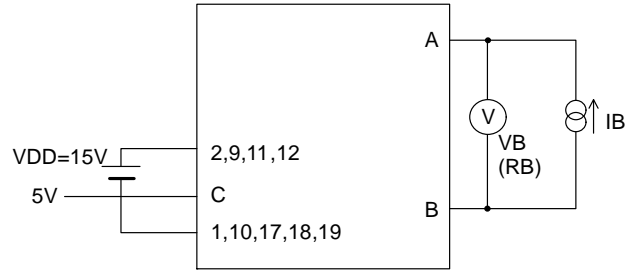

Figure 19. Test Circuit for RB

- IQBS, IQDD

	VBS U+	VBS V+	VBS W+	V _{DD}
A	34	28	22	2
B	32	26	20	1

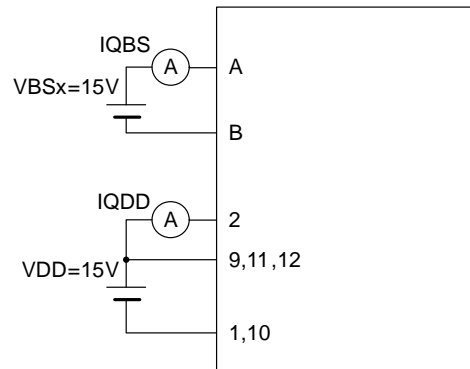

Figure 20. Test Circuit for I_D

- Switching Time (The circuit is a representative example of the Inverter Low side U phase.)

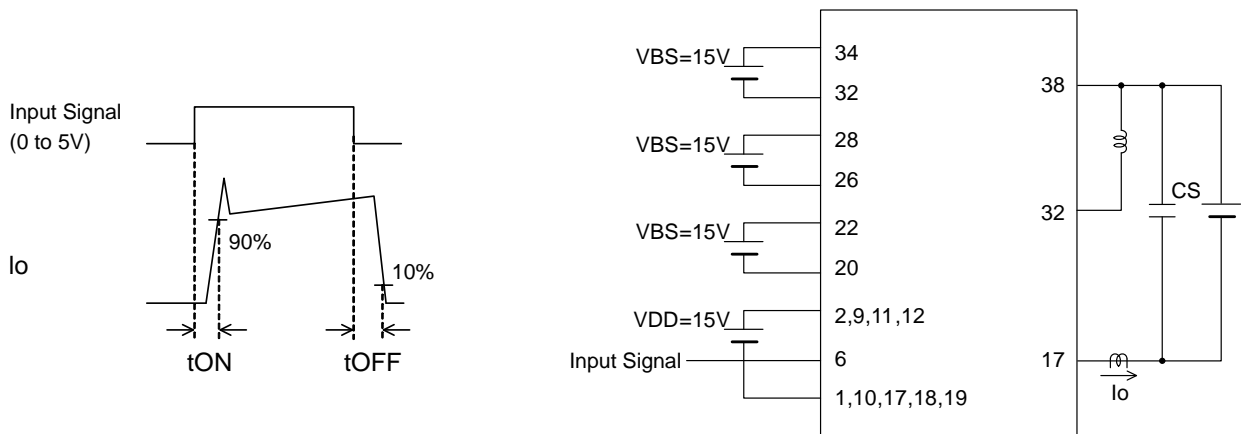
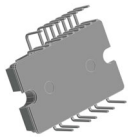
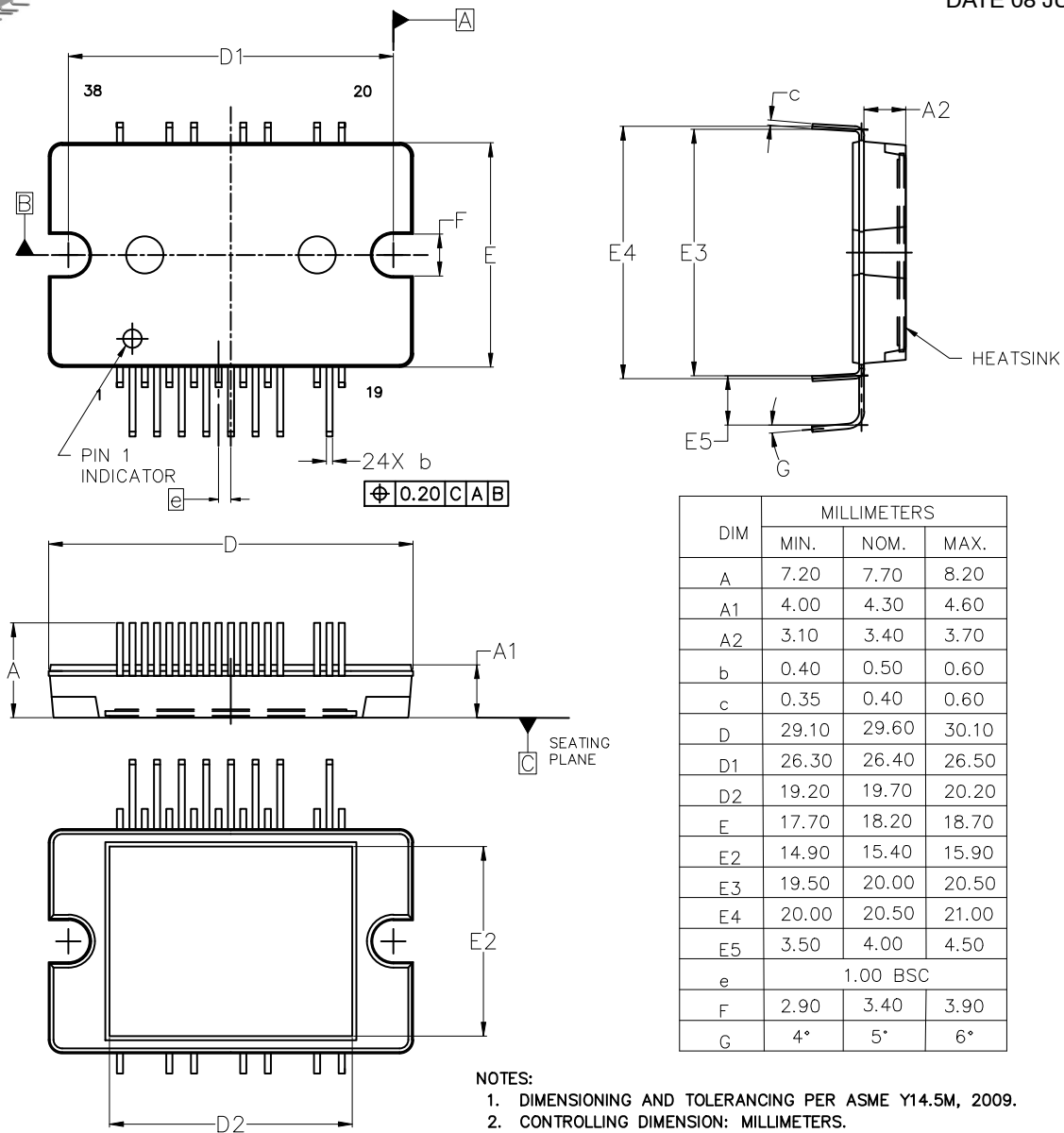

Figure 21. Test Circuit for Switching Time



DIP-38, 29.60x18.20x7.70, 1.00P (EP-4)
CASE 125BS
ISSUE C

DATE 08 JUN 2026



DIM	MILLIMETERS		
	MIN.	NOM.	MAX.
A	7.20	7.70	8.20
A1	4.00	4.30	4.60
A2	3.10	3.40	3.70
b	0.40	0.50	0.60
c	0.35	0.40	0.60
D	29.10	29.60	30.10
D1	26.30	26.40	26.50
D2	19.20	19.70	20.20
E	17.70	18.20	18.70
E2	14.90	15.40	15.90
E3	19.50	20.00	20.50
E4	20.00	20.50	21.00
E5	3.50	4.00	4.50
e	1.00 BSC		
F	2.90	3.40	3.90
G	4°	5°	6°

- NOTES:
1. DIMENSIONING AND TOLERANCING PER ASME Y14.5M, 2009.
 2. CONTROLLING DIMENSION: MILLIMETERS.
 3. DIMENSION b APPLIES TO THE PLATED LEAD AND IS MEASURED BETWEEN 0.10 AND 0.25 FROM THE LEAD TIP.
 4. PACKAGE IS MISSING PINS: 15, 16, 21, 23, 24, 25, 27, 29, 30, 31, 33, 35, 36, AND 37.

GENERIC MARKING DIAGRAM*

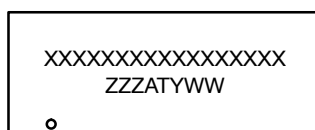

XXXX = Specific Device Code
 ZZZ = Lot ID
 AT = Assembly & Test Location
 Y = Year
 WW = Work Week

*This information is generic. Please refer to device data sheet for actual part marking. Pb-Free indicator, "G" or microdot "•", may or may not be present. Some products may not follow the Generic Marking.

DOCUMENT NUMBER:	98AON92315G	Electronic versions are uncontrolled except when accessed directly from the Document Repository. Printed versions are uncontrolled except when stamped "CONTROLLED COPY" in red.
DESCRIPTION:	DIP-38, 29.60x18.20x7.70, 1.00P (EP-4)	PAGE 1 OF 1

onsemi and onsemi are trademarks of Semiconductor Components Industries, LLC dba onsemi or its subsidiaries in the United States and/or other countries. onsemi reserves the right to make changes without further notice to any products herein. onsemi makes no warranty, representation or guarantee regarding the suitability of its products for any particular purpose, nor does onsemi assume any liability arising out of the application or use of any product or circuit, and specifically disclaims any and all liability, including without limitation special, consequential or incidental damages. onsemi does not convey any license under its patent rights nor the rights of others.

onsemi, **Onsemi**, and other names, marks, and brands are registered and/or common law trademarks of Semiconductor Components Industries, LLC dba "**onsemi**" or its affiliates and/or subsidiaries in the United States and/or other countries. **onsemi** owns the rights to a number of patents, trademarks, copyrights, trade secrets, and other intellectual property. A listing of **onsemi**'s product/patent coverage may be accessed at www.onsemi.com/site/pdf/Patent-Marking.pdf. **onsemi** reserves the right to make changes at any time to any products or information herein, without notice. The information herein is provided "as-is" and **onsemi** makes no warranty, representation or guarantee regarding the accuracy of the information, product features, availability, functionality, or suitability of its products for any particular purpose, nor does **onsemi** assume any liability arising out of the application or use of any product or circuit, and specifically disclaims any and all liability, including without limitation special, consequential or incidental damages. Buyer is responsible for its products and applications using **onsemi** products, including compliance with all laws, regulations and safety requirements or standards, regardless of any support or applications information provided by **onsemi**. "Typical" parameters which may be provided in **onsemi** data sheets and/or specifications can and do vary in different applications and actual performance may vary over time. All operating parameters, including "Typicals" must be validated for each customer application by customer's technical experts. **onsemi** does not convey any license under any of its intellectual property rights nor the rights of others. **onsemi** products are not designed, intended, or authorized for use as a critical component in life support systems or any FDA Class 3 medical devices or medical devices with a same or similar classification in a foreign jurisdiction or any devices intended for implantation in the human body. Should Buyer purchase or use **onsemi** products for any such unintended or unauthorized application, Buyer shall indemnify and hold **onsemi** and its officers, employees, subsidiaries, affiliates, and distributors harmless against all claims, costs, damages, and expenses, and reasonable attorney fees arising out of, directly or indirectly, any claim of personal injury or death associated with such unintended or unauthorized use, even if such claim alleges that **onsemi** was negligent regarding the design or manufacture of the part. **onsemi** is an Equal Opportunity/Affirmative Action Employer. This literature is subject to all applicable copyright laws and is not for resale in any manner.

ADDITIONAL INFORMATION

TECHNICAL PUBLICATIONS:

Technical Library: www.onsemi.com/design/resources/technical-documentation
onsemi Website: www.onsemi.com

ONLINE SUPPORT: www.onsemi.com/support

For additional information, please contact your local Sales Representative at www.onsemi.com/support/sales