

Intelligent Power Module (IPM)

600 V, 5 A

NFAP0560L3TT

The NFAP0560L3TT is a fully-integrated inverter power stage consisting of a high-voltage driver, six IGBT's and a thermistor, suitable for driving permanent magnet synchronous (PMSM) motors, brushless-DC (BLDC) motors and AC asynchronous motors. The IGBT's are configured in a 3-phase bridge with separate emitter connections for the lower legs for maximum flexibility in the choice of control algorithm. The power stage has a full range of protection functions including cross-conduction protection, external shutdown and under-voltage lockout functions. An internal comparator and reference connected to the over-current protection circuit allows the designer to set the over-current protection level.

Features

- Three-phase 5 A/600 V IGBT Module with Integrated Drivers
- Compact 44 mm x 20.9 mm Single In-line Package
- Built-in Under Voltage Protection
- Cross-conduction Protection
- ITRIP Input to Shut Down All IGBTs
- Integrated Bootstrap Diodes and Resistors
- Thermistor for Substrate Temperature Measurement
- UL1557 Certification (File number: E339285)

Typical Applications

- Industrial Drives
- Industrial Pumps
- Industrial Fans
- Industrial Automation

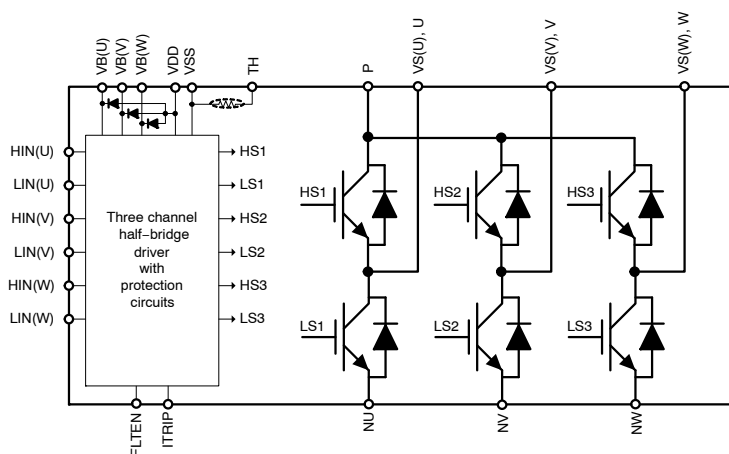
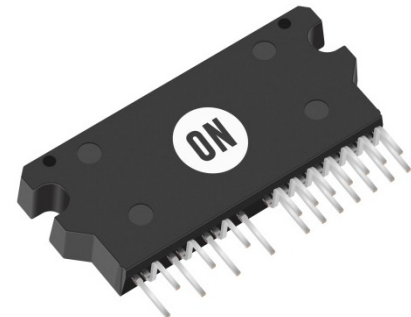

Figure 1. Functional Diagram



ON Semiconductor®

www.onsemi.com



SIP29
CASE 127FB

MARKING DIAGRAM



NFAP0560L3TT = Specific Device Code
 ZZZ = Assembly Lot Code
 A = Assembly Location
 T = Test Location
 Y = Year
 WW = Work Week

Device marking is on package top side

ORDERING INFORMATION

Device	Package	Shipping
NFAP0560L3TT	SIP29 (Pb-Free)	120 / Box

NFAP0560L3TT

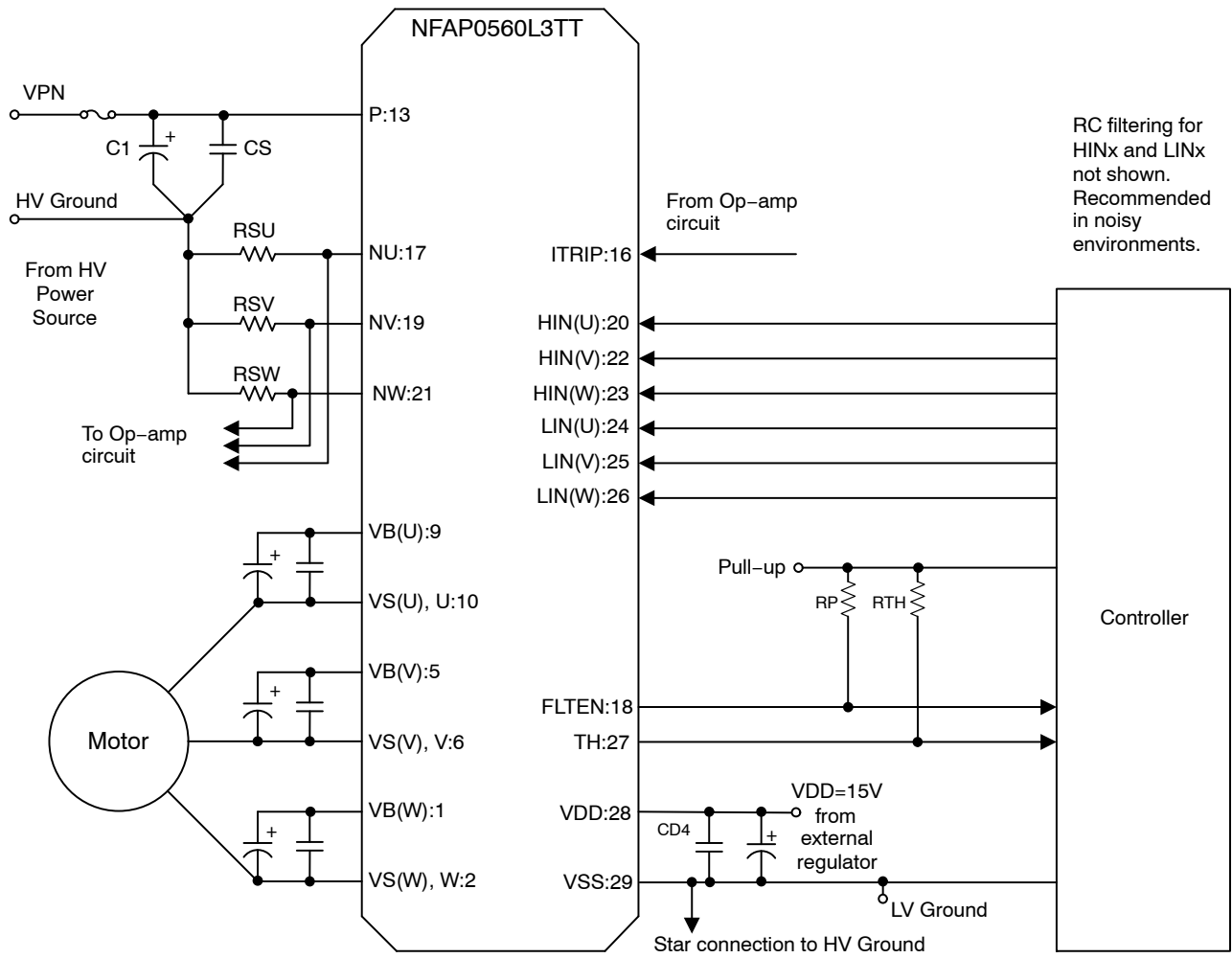

Figure 2. Application Schematic

NFAP0560L3TT

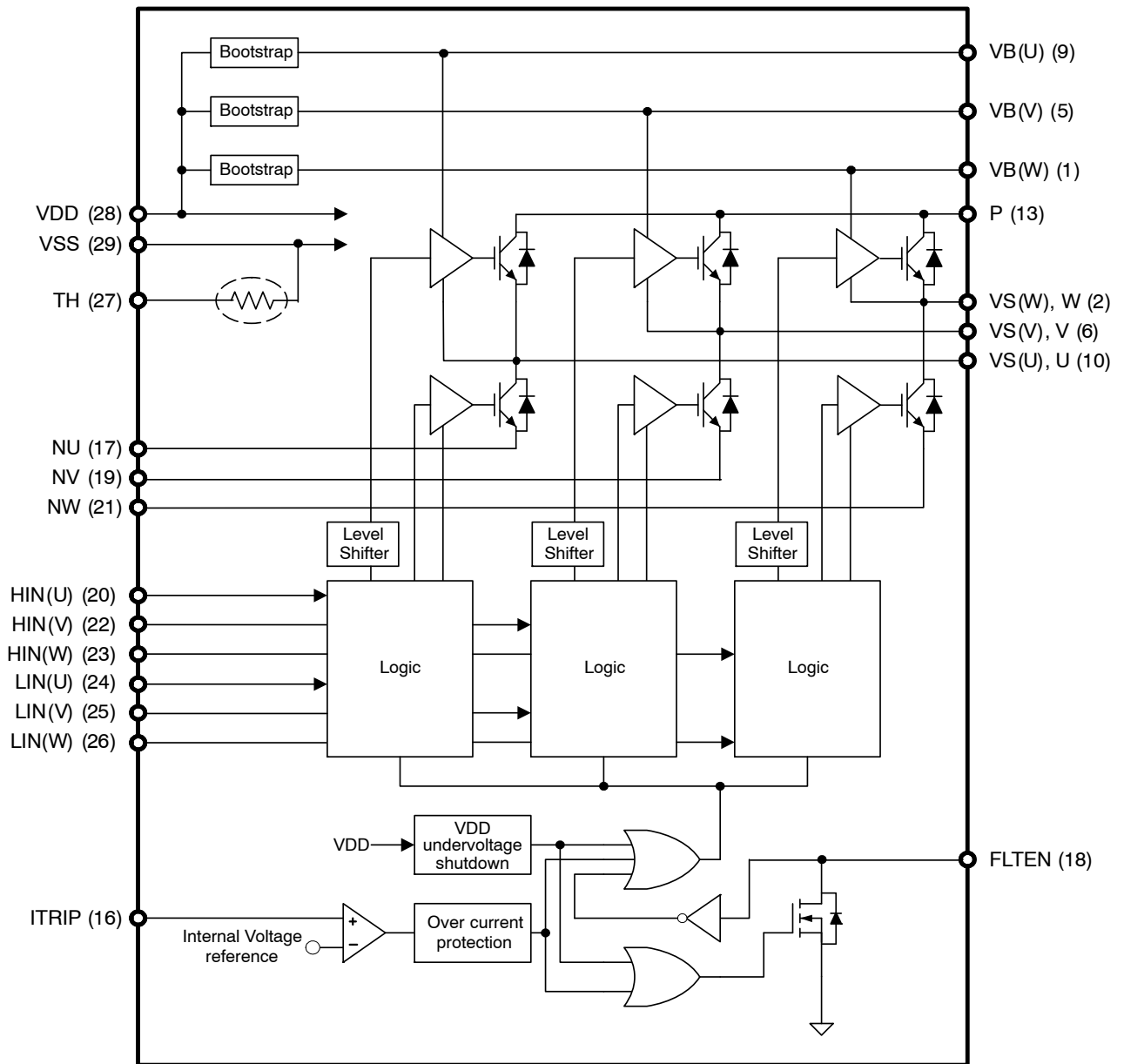

Figure 3. Simplified Block Diagram

NFAP0560L3TT

Table 1. PIN FUNCTION DESCRIPTION

Pin	Name	Description
1	VB(W)	High-Side Bias Voltage for W phase IGBT Driving
2	VS(W), W	High-Side Bias Voltage GND for W phase IGBT Driving, Output for W Phase
5	VB(V)	High-Side Bias Voltage for V phase IGBT Driving
6	VS(V), V	High-Side Bias Voltage GND for V phase IGBT Driving, Output for V Phase
9	VB(U)	High-Side Bias Voltage for U phase IGBT Driving
10	VS(U), U	High-Side Bias Voltage GND for U phase IGBT Driving, Output for U Phase
13	P	Positive DC-Link Input
16	ITRIP	Input for Over Current Protection
17	NU	Negative DC-Link Input for U Phase
18	FLTEN	Fault Output, Enable Input
19	NV	Negative DC-Link Input for V Phase
20	HIN(U)	Signal Input for High-Side U Phase
21	NW	Negative DC-Link Input for W Phase
22	HIN(V)	Signal Input for High-Side V Phase
23	HIN(W)	Signal Input for High-Side W Phase
24	LIN(U)	Signal Input for Low-Side U Phase
25	LIN(V)	Signal Input for Low-Side V Phase
26	LIN(W)	Signal Input for Low-Side W Phase
27	TH	Series Resistor for Thermistor (Temperature Detection)
28	VDD	Low-Side Bias Voltage for IC and IGBTs Driving
29	VSS	Low-Side Common Supply Ground

NOTE: Pins 3, 4, 7, 8, 11, 12, 14 and 15 are not present

Table 2. ABSOLUTE MAXIMUM RATINGS at Tc = 25°C (Note 1)

Parameter	Symbol	Conditions	Rating	Unit
Supply Voltage	VPN	P-NU,NV,NW, VPN (surge) < 500 V (Note 2)	450	V
Collector - Emitter Voltage	Vces	P-U,V,W; U-NU; V-NV; W-NW	600	V
Each IGBT Collector Current	±Ic	P,U,V,W,NU,NV,NW terminal current	±5	A
Each IGBT Collector Current (Peak)	±Icp	Tc = 25°C, Under 1ms Pulse Width	10	A
Corrector Dissipation	Pc	Tc = 25°C, Per One Chip	12	W
High-Side Control Bias voltage	VBS	VB(U)-VS(U), VB(V)-VS(V), VB(W)-VS(W) (Note 3)	-0.3 to +20.0	V
Control Supply Voltage	VDD	VDD-VSS	-0.3 to +20.0	V
Input Signal Voltage	VIN	HIN(U), HIN(V), HIN(W), LIN(U), LIN(V), LIN(W)-VSS	-0.3 to VDD	V
FLTEN Terminal Voltage	VFLTEN	FLTEN-VSS	-0.3 to VDD	V
Current Sensing Input Voltage	VITRIP	ITRIP-VSS	-0.3 to +7.0	V
Operating Junction Temperature	Tj		150	°C
Storage Temperature	Tstg		-40 to +125	°C
Module Case Operation Temperature	Tc		-40 to +125	°C
Tightening Torque	MT	Case mounting screws	0.9	Nm
Isolation Voltage	Viso	50 Hz sine wave AC 1 minute (Note 4)	2000	Vrms

Stresses exceeding those listed in the Maximum Ratings table may damage the device. If any of these limits are exceeded, device functionality should not be assumed, damage may occur and reliability may be affected.

1. Refer to ELECTRICAL CHARACTERISTICS, RECOMMENDED OPERATING RANGES and/or APPLICATION INFORMATION for Safe Operating parameters.
2. This surge voltage developed by the switching operation due to the wiring inductance between P and NU, NV, NW terminal.
3. VBS = VB(U)-VS(U), VB(V)-VS(V), VB(W)-VS(W)
4. Test conditions: AC2500V, 1 s

NFAP0560L3TT

Table 3. RECOMMENDED OPERATING RANGES

Parameter	Symbol	Conditions	Min	Typ	Max	Unit
Supply Voltage	VPN	P-NU,NV,NW	0	280	450	V
High-Side Control Bias Voltage	VBS	VB(U)-VS(U), VB(V)-VS(V), VB(W)-VS(W)	13.0	15	17.5	V
Control Supply Voltage	VDD	VDD-VSS	14.0	15	16.5	V
ON-state Input Voltage	VIN(ON)	HIN(U), HIN(V), HIN(W), LIN(U), LIN(V), LIN(W)-VSS	3.0	-	5.0	V
OFF-state Input Voltage	VIN(OFF)		0	-	0.3	V
PWM Frequency	fPWM		1	-	20	kHz
Dead Time	DT	Turn-off to Turn-on (external)	0.5	-	-	μs
Allowable Input Pulse Width	PWIN	ON and OFF	1	-	-	μs
Tightening Torque		'M3' type screw	0.6	-	0.9	Nm

Functional operation above the stresses listed in the Recommended Operating Ranges is not implied. Extended exposure to stresses beyond the Recommended Operating Ranges limits may affect device reliability.

Table 4. ELECTRICAL CHARACTERISTICS at T_c = 25°C, V_{BIAS} (VBS, VDD) = 15 V unless otherwise noted.

Parameter	Test Conditions	Symbol	Min	Typ	Max	Unit
POWER OUTPUT SECTION						
Collector-Emitter Leakage Current	V _{ce} = 600 V	I _{ces}	-	-	1	mA
Bootstrap Diode Reverse Current	VR(DB) = 600 V	IR(DB)	-	-	1	mA
Collector-Emitter Saturation Voltage	VDD = VBS = 15 V, I _N = 5 V, I _c = 5 A, T _j = 25°C	VCE(sat)	-	2.0	2.6	V
	VDD = VBS = 15 V, I _N = 5 V, I _c = 2.5 A, T _j = 100°C		-	1.6	-	V
FWDi Forward Voltage	I _N = 0 V, I _c = -5 A, T _j = 25°C	VF	-	1.8	2.4	V
	I _N = 0 V, I _c = -2.5 A, T _j = 100°C		-	1.4	-	V
Junction to Case Thermal Resistance	Inverter IGBT Part (per 1/6 Module)	R _{th(j-c)Q}	-	-	9.8	°C/W
	Inverter FRD Part (per 1/6 Module)	R _{th(j-c)F}	-	-	11.6	°C/W
DRIVER SECTION						
Quiescent VBS Supply Current	VBS = 15 V, HIN = 0 V, per driver	IQBS	-	0.07	0.4	mA
Quiescent VDD Supply Current	VDD = 15 V, HIN = 0 V, VDD-VSS	IQDDL	-	0.85	3.0	mA
ON Threshold Voltage	HIN(U), HIN(V), HIN(W), LIN(U), LIN(V), LIN(W)-VSS	VIN(ON)	-	-	2.5	V
OFF Threshold Voltage		VIN(OFF)	0.8	-	-	V
Logic 1 Input Current	VIN = +3.3 V	IIN+	-	660	-	μA
Logic 0 Input Current	VIN = 0 V	IIN-	-	-	2	μA
FLTEN Terminal Sink Current	FAULT: ON / VFLTEN = 0.1 V	I _{oSD}	-	2	-	mA
Fault-Output Pulse Width	FLTEN-VSS	tFOD	20	-	-	μs
Enable Threshold	FLTEN-VSS	VEN+	-	-	2.5	V
		VEN-	0.8	-	-	V
Short Circuit Trip Level	ITRIP-VSS	VSC(ref)	0.44	0.49	0.54	V
High-Side Control Bias Voltage Under-Voltage Protection	Reset Level	UVBSR	10.3	11.1	11.9	V
	Detection Level	UVBSD	10.1	10.9	11.7	V
Supply Voltage Under-Voltage Protection	Reset Level	UVDDR	10.3	11.1	11.7	V
	Detection Level	UVDDD	10.1	10.9	11.5	V

Product parametric performance is indicated in the Electrical Characteristics for the listed test conditions, unless otherwise noted. Product performance may not be indicated by the Electrical Characteristics if operated under different conditions.

NFAP0560L3TT

Table 5. ELECTRICAL CHARACTERISTICS

at $T_c = 25^\circ\text{C}$, V_{BIAS} (VBS, VDD) = 15 V, $V_{\text{CE}} = 300$ V, $L = 3.0$ mH unless otherwise noted.

Parameter	Test Conditions	Symbol	Min	Typ	Max	Unit
SWITCHING CHARACTER						
Switching Time	$I_C = 5$ A, $T_J = 25^\circ\text{C}$	t_{ON}	-	0.5	1.0	μs
		t_{OFF}	-	0.5	1.0	μs
Turn-on Switching Loss	$I_C = 2.5$ A, $T_J = 25^\circ\text{C}$	E_{ON}	-	50	-	μJ
Turn-off Switching Loss		E_{OFF}	-	35	-	μJ
Total Switching Loss		E_{TOT}	-	85	-	μJ
Turn-on Switching Loss	$I_C = 2.5$ A, $T_J = 100^\circ\text{C}$	E_{ON}	-	70	-	μJ
Turn-off Switching Loss		E_{OFF}	-	40	-	μJ
Total Switching Loss		E_{TOT}	-	110	-	μJ
Diode Reverse Recovery Energy	$I_C = 2.5$ A, $T_J = 100^\circ\text{C}$	E_{REC}	-	20	-	μJ
Diode Reverse Recovery Time		t_{RR}	-	120	-	ns
Reverse Bias Safe Operating Area	$I_C = 10$ A, $V_{\text{CE}} = 450$ V	RBSOA	Full Square			
Short Circuit Safe Operating Area	$V_{\text{CE}} = 400$ V, $T_J = 100^\circ\text{C}$	SCSOA	5	-	-	μs

TYPICAL CHARACTERISTICS INV SECTION

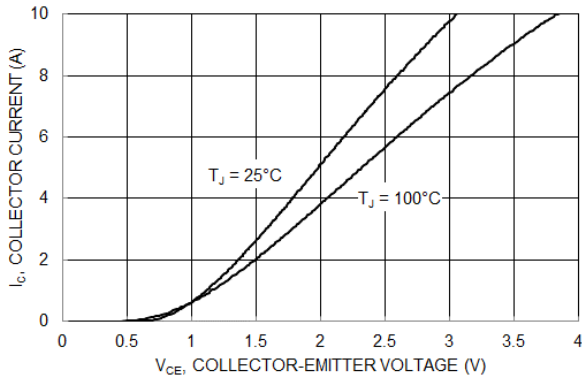

Figure 4. V_{CE} vs. I_C for Different Temperatures ($V_{\text{DD}} = 15$ V)

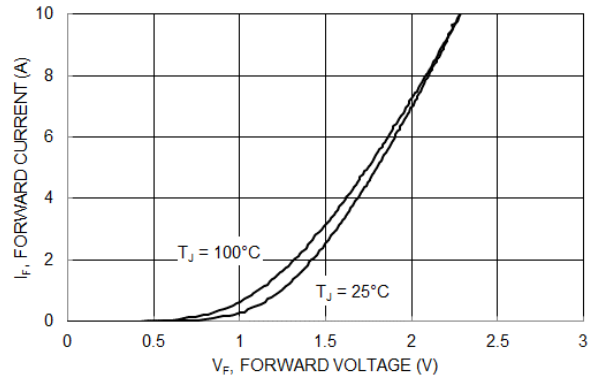

Figure 5. V_F vs. I_F for Different Temperatures

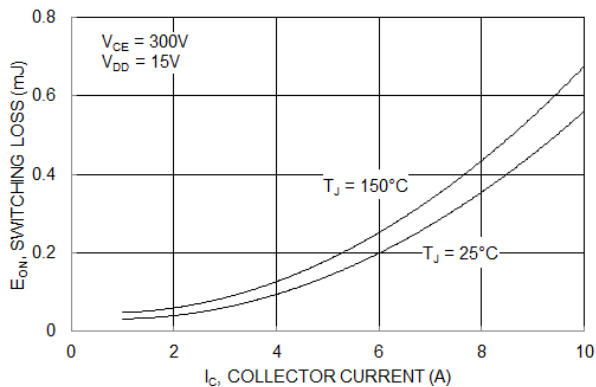

Figure 6. E_{ON} vs. I_C for Different Temperatures

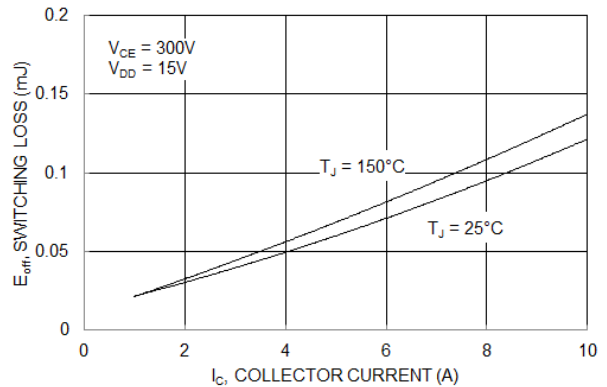

Figure 7. E_{OFF} vs. I_C for Different Temperatures

TYPICAL CHARACTERISTICS INV SECTION

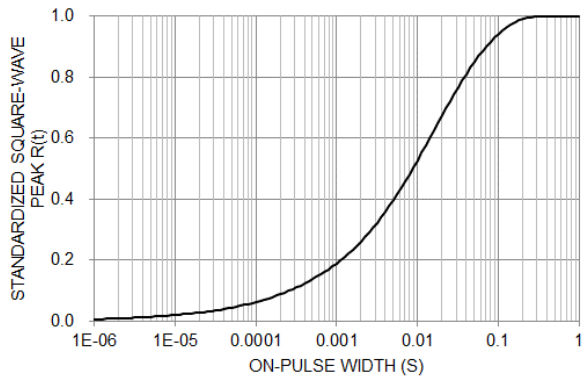

Figure 8. Thermal Impedance Plot

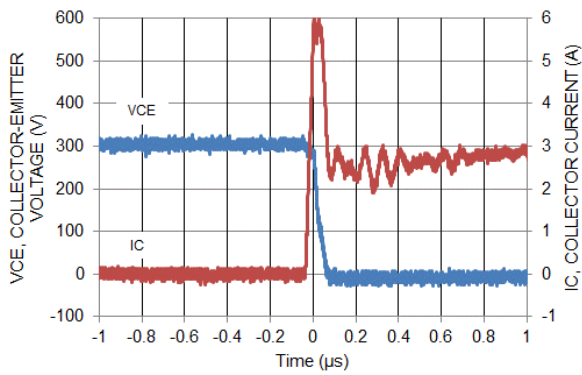

Figure 9. Turn-on Waveform
 $T_J = 100^{\circ}\text{C}$, $V_{CC} = 300\text{ V}$

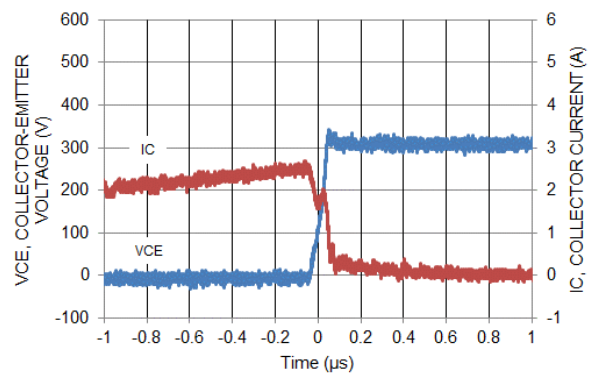

Figure 10. Turn-off Waveform
 $T_J = 100^{\circ}\text{C}$, $V_{CC} = 300\text{ V}$

APPLICATIONS INFORMATION

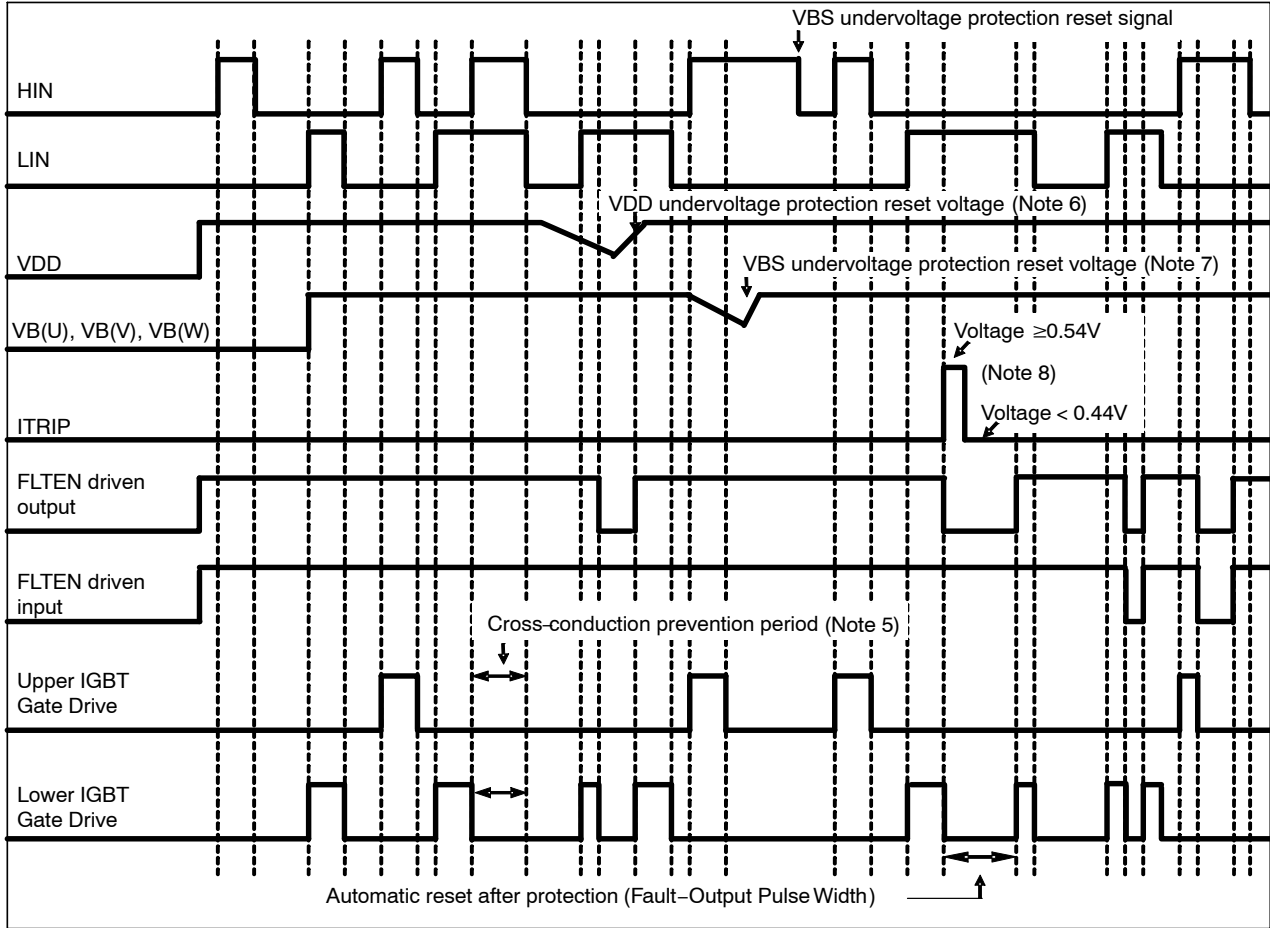

Figure 11. Input / Output Timing Chart

5. This section of the timing diagram shows the effect of cross-conduction prevention.
6. This section of the timing diagram shows that when the voltage on VDD decreases sufficiently all gate output signals will go low, switching off all six IGBTs. When the voltage on VDD rises sufficiently, normal operation will resume.
7. This section shows that when the bootstrap voltage on VB(U) (VB(V), VB(W)) drops, the corresponding high side output U (V, W) is switched off. When the voltage on VB(U) (VB(V), VB(W)) rises sufficiently, normal operation will resume.
8. This section shows that when the voltage on ITRIP exceeds the threshold, all IGBT's are turned off. Normal operation resumes later after the over-current condition is removed.

Table 6. INPUT / OUTPUT LOGIC TABLE

INPUT			OUTPUT			
HIN	LIN	ITRIP	High side IGBT	Low side IGBT	U,V,W	FAULT
H	L	L	ON	OFF	P	OFF
L	H	L	OFF	ON	NU, NV, NW	OFF
L	L	L	OFF	OFF	High Impedance	OFF
H	H	L	OFF	OFF	High Impedance	OFF
X	X	H	OFF	OFF	High Impedance	ON

Table 7. THERMISTOR CHARACTERISTICS

Parameter	Symbol	Condition	Min	Typ	Max	Unit
Resistance	R ₂₅	T _{th} =25°C	45.59	47	48.41	kΩ
	R ₁₂₅	T _{th} =125°C	1.34	1.45	1.59	kΩ
B-Constant (25 to 50°C)	B		3953	4021	4033	K
Temperature Range			-40		+125	°C

NFAP0560L3TT

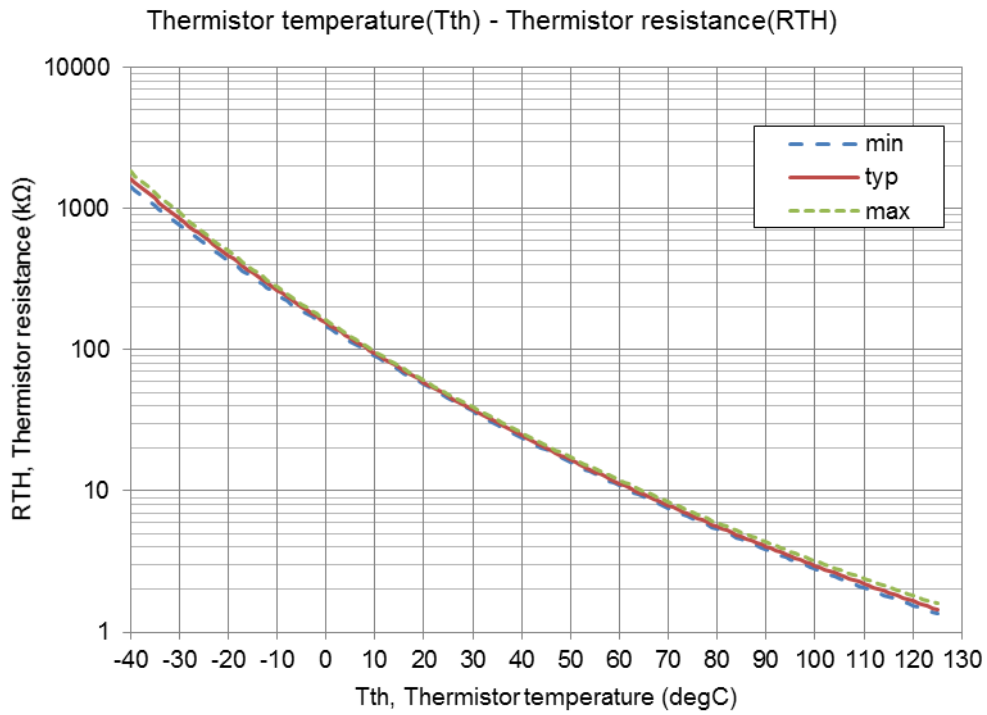

Figure 12. Thermistor Resistance vs. Thermistor Temperature

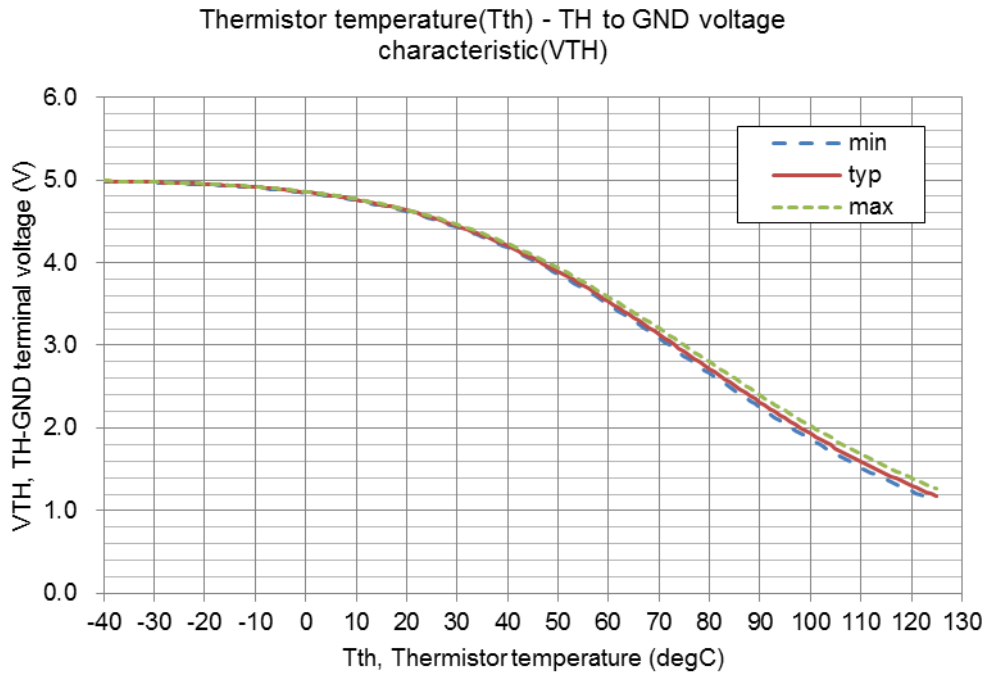

Figure 13. Thermistor Voltage vs. Thermistor Temperature
Conditions: RTH = 4.7 kΩ, pull-up voltage 5.0 V (see Figure 12)

FLTEN Pin

The FLTEN pin is connected to an open-drain FAULT output and an ENABLE input, it is required a pull-up resistor. If the pull-up voltage is 5 V, use a pull-up resistor with a value of 6.8 kΩ or higher. If the pull-up voltage is 15 V, use a pull-up resistor with a value of 20 kΩ or higher. The pulled up voltage in normal operation for the FLTEN pin should be above 2.5 V, noting that it is connected to an internal ENABLE input. The FAULT output is triggered if there is a VDD under-voltage or an overcurrent condition.

Driving the FLTEN terminal pin is used to enable or shut down the built-in driver. If the voltage on the FLTEN pin rises above the positive going ENABLE threshold, the output drivers are enabled. If the voltage on the FLTEN pin falls below the negative going ENABLE threshold, the drivers are disabled.

Under-voltage Protection

If VDD goes below the VDD supply under-voltage lockout falling threshold, the FAULT output is switched on. The FAULT output stays on until VDD rises above the VDD supply under-voltage lockout rising threshold. After VDD has risen above the threshold to enable normal operation, the driver waits to receive an input signal on the LIN input before enabling the driver for the HIN signal. The hysteresis is approximately 200 mV.

Overcurrent Protection

An over-current condition is detected if the voltage on the ITRIP pin is larger than the reference voltage. There is a blanking time of typically 350 ns to improve noise immunity. After a shutdown propagation delay of typically 0.9 μs, the FAULT output is switched on. The FAULT output is held on for 20 μs (minimum).

The over-current protection threshold should be set to be equal or lower to 2 times the module rated current (Io).

An additional fuse is recommended to protect against system level or abnormal over-current fault conditions.

Capacitors on High Voltage and VDD Supplies

Both the high voltage and VDD supplies require an electrolytic capacitor and an additional high frequency capacitor. The recommended value of the high frequency capacitor is between 100 nF and 10 μF.

Minimum Input Pulse Width

When input pulse width is less than 1 μs, an output may not react to the pulse. (Both ON signal and OFF signal)

Calculation of Bootstrap Capacitor Value

The bootstrap capacitor value CB is calculated using the following approach. The following parameters influence the choice of bootstrap capacitor:

- VBS: Bootstrap power supply.
15 V is recommended.
- QG: Total gate charge of IGBT at VBS = 15 V.
17 nC
- UVLO: Falling threshold for UVLO.
Specified as 12 V.
- IDMAX: High-side drive power dissipation.
Specified as 0.4 mA
- TONMAX: Maximum ON pulse width of high side IGBT.

Capacitance Calculation Formula:

$$CB = (QG + IDMAX * TONMAX)/(VBS - UVLO)$$

The relationship between TONMAX and CB becomes as follows. CB is recommended to be approximately 3 times the value calculated above. The recommended value of CB is in the range of 1 to 47 μF, however, the value needs to be verified prior to production. When not using the bootstrap circuit, each high side driver power supply requires an external independent power supply.

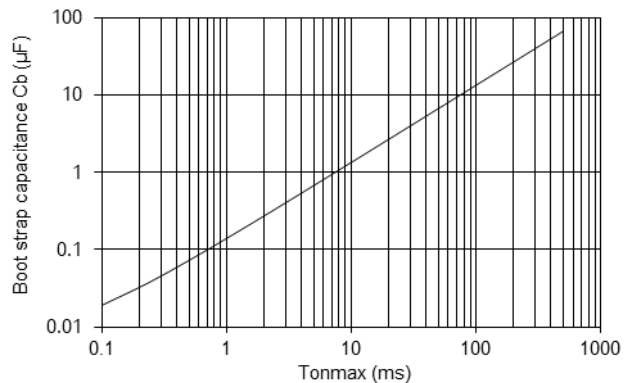

Figure 14. Bootstrap Capacitance vs. Tonmax

NFAP0560L3TT

TEST CIRCUITS

I_{ces}, I_R(DB)

	U+	V+	W+	U-	V-	W-
A	13	13	13	10	6	2
B	10	6	2	17	19	21

U+,V+,W+ : High side phase
U-,V-,W- : Low side phase

	U(DB)	V(DB)	W(DB)
A	9	5	1
B	29	29	29

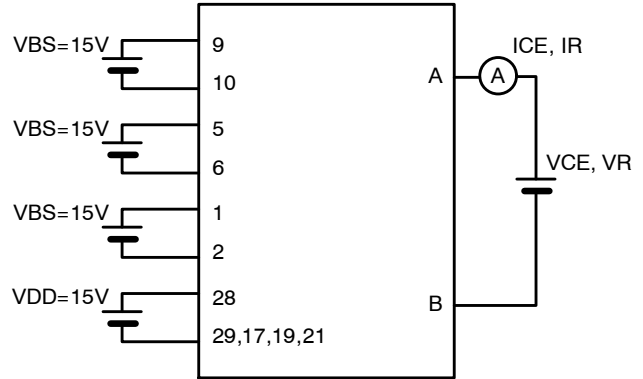

Figure 15. Test Circuit for I_{CE}

V_{CE}(sat) (Test by pulse)

	U+	V+	W+	U-	V-	W-
A	13	13	13	10	6	2
B	10	6	2	17	19	21
C	20	22	23	24	25	26

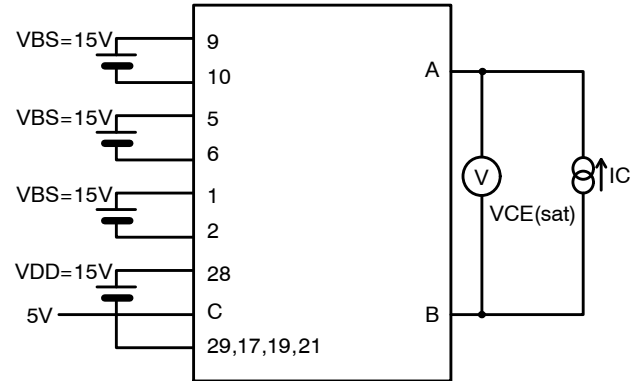

Figure 16. Test Circuit for V_{CE}(SAT)

V_F (Test by pulse)

	U+	V+	W+	U-	V-	W-
A	13	13	13	10	6	2
B	10	6	2	17	19	21

	U(DB)	V(DB)	W(DB)
A	9	5	1
B	28	28	28

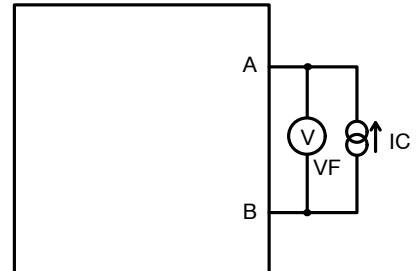

Figure 17. Test Circuit for V_F

I_{QBS}, I_{QDDL}

	VBS U+	VBS V+	VBS W+	V _{DD}
A	9	5	1	28
B	10	6	2	29

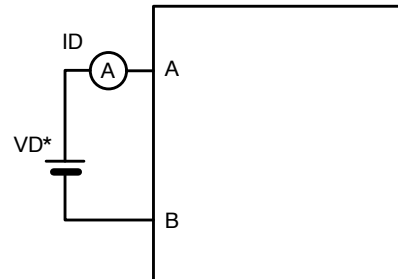

Figure 18. Test Circuit for I_D

NFAP0560L3TT

SWITCHING TIME (The circuit is a representative example of the lower side U phase.)

	U+	V+	W+	U-	V-	W-
A	13	13	13	13	13	13
B	17	19	21	17	19	21
C	10	6	2	13	13	13
D	17	19	21	10	6	2
E	20	22	23	24	25	26

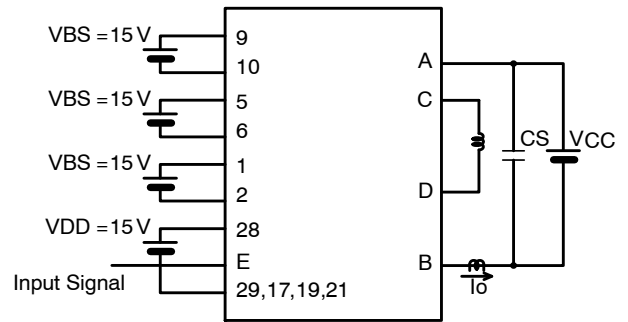
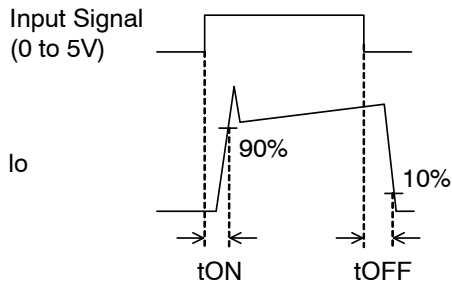
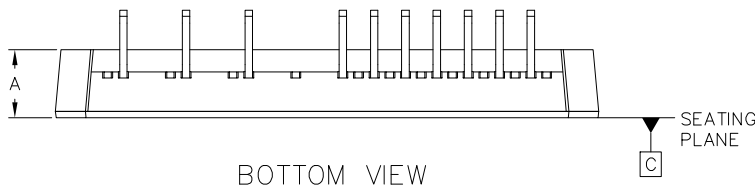
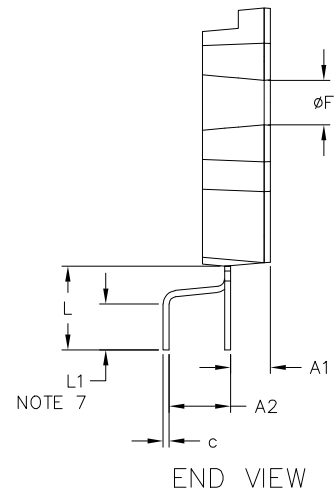
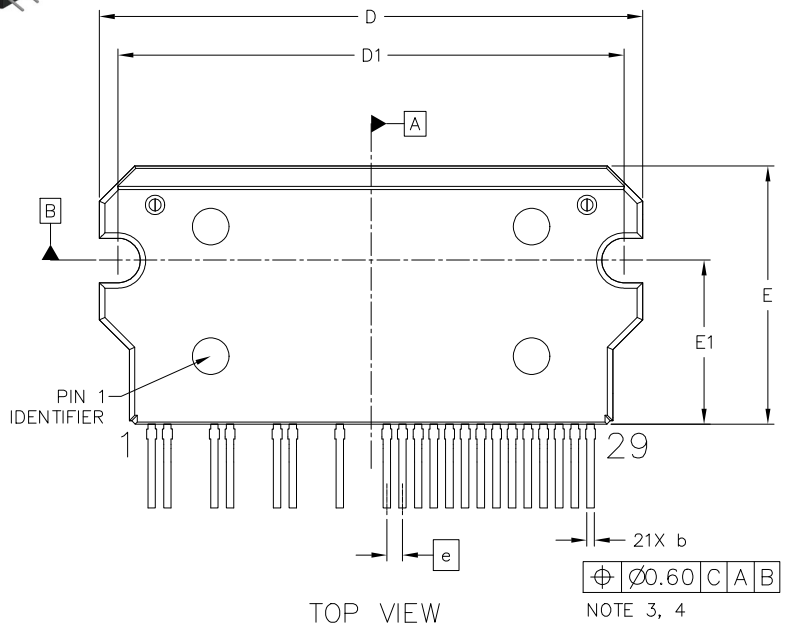
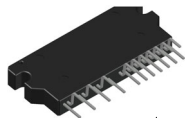

Figure 19. Test Circuit for Switching Time



SIP-29 44.00x20.90x5.50, 1.27P
CASE 127FB
ISSUE C

DATE 08 JUN 2026



- NOTES:
1. DIMENSIONING AND TOLERANCING AS PER SAME Y14.5M, 2018.
 2. CONTROLLING DIMENSIONS: MILLIMETERS.
 3. DIMENSION b AND c APPLY TO THE PLATED LEADS AND ARE MEASURED BETWEEN 1.00 AND 2.00 FROM THE LEAD TIP.
 4. POSITION OF THE LEAD IS DETERMINED AT THE ROOT OF THE LEAD WHERE IT EXITS THE PACKAGE BODY.
 5. PIN 1 IDENTIFICATION IS A MIRRORED SURFACE INDENT.
 6. MISSING PINS ARE 3, 4, 7, 8, 11, 12, 14 AND 15.
 7. L1 IS THE STRAIGHT PORTION OF THE LEAD AFTER THE BEND.
 8. FP-1

MILLIMETERS			
DIM	MIN	NOM	MAX
A	5.30	5.50	5.70
A1	3.00	3.20	3.40
A2	4.50	5.00	5.50
b	0.55	0.60	0.80
c	0.45	0.50	0.70
D	43.50	44.00	44.50
D1	40.50	41.00	41.50
E	20.40	20.90	21.40
E1	12.75	13.25	13.75
e	1.27 BSC		
F	3.10	3.60	4.10
L	6.30	6.80	7.30
L1	3.23	3.73	4.23

GENERIC MARKING DIAGRAM*

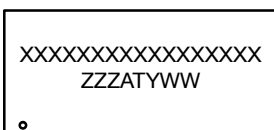

XXXX = Specific Device Code
 ZZZ = Assembly Lot Code
 AT = Assembly & Test Location
 Y = Year
 WW = Work Week

*This information is generic. Please refer to device data sheet for actual part marking. Pb-Free indicator, "G" or microdot "•", may or may not be present. Some products may not follow the Generic Marking.

DOCUMENT NUMBER:	98AON01721H	Electronic versions are uncontrolled except when accessed directly from the Document Repository. Printed versions are uncontrolled except when stamped "CONTROLLED COPY" in red.
DESCRIPTION:	SIP-29 44.00x20.90x5.50, 1.27P	PAGE 1 OF 1

onsemi and onsemi are trademarks of Semiconductor Components Industries, LLC dba onsemi or its subsidiaries in the United States and/or other countries. onsemi reserves the right to make changes without further notice to any products herein. onsemi makes no warranty, representation or guarantee regarding the suitability of its products for any particular purpose, nor does onsemi assume any liability arising out of the application or use of any product or circuit, and specifically disclaims any and all liability, including without limitation special, consequential or incidental damages. onsemi does not convey any license under its patent rights nor the rights of others.

onsemi, **Onsemi**, and other names, marks, and brands are registered and/or common law trademarks of Semiconductor Components Industries, LLC dba "**onsemi**" or its affiliates and/or subsidiaries in the United States and/or other countries. **onsemi** owns the rights to a number of patents, trademarks, copyrights, trade secrets, and other intellectual property. A listing of **onsemi**'s product/patent coverage may be accessed at www.onsemi.com/site/pdf/Patent-Marking.pdf. **onsemi** reserves the right to make changes at any time to any products or information herein, without notice. The information herein is provided "as-is" and **onsemi** makes no warranty, representation or guarantee regarding the accuracy of the information, product features, availability, functionality, or suitability of its products for any particular purpose, nor does **onsemi** assume any liability arising out of the application or use of any product or circuit, and specifically disclaims any and all liability, including without limitation special, consequential or incidental damages. Buyer is responsible for its products and applications using **onsemi** products, including compliance with all laws, regulations and safety requirements or standards, regardless of any support or applications information provided by **onsemi**. "Typical" parameters which may be provided in **onsemi** data sheets and/or specifications can and do vary in different applications and actual performance may vary over time. All operating parameters, including "Typicals" must be validated for each customer application by customer's technical experts. **onsemi** does not convey any license under any of its intellectual property rights nor the rights of others. **onsemi** products are not designed, intended, or authorized for use as a critical component in life support systems or any FDA Class 3 medical devices or medical devices with a same or similar classification in a foreign jurisdiction or any devices intended for implantation in the human body. Should Buyer purchase or use **onsemi** products for any such unintended or unauthorized application, Buyer shall indemnify and hold **onsemi** and its officers, employees, subsidiaries, affiliates, and distributors harmless against all claims, costs, damages, and expenses, and reasonable attorney fees arising out of, directly or indirectly, any claim of personal injury or death associated with such unintended or unauthorized use, even if such claim alleges that **onsemi** was negligent regarding the design or manufacture of the part. **onsemi** is an Equal Opportunity/Affirmative Action Employer. This literature is subject to all applicable copyright laws and is not for resale in any manner.

ADDITIONAL INFORMATION

TECHNICAL PUBLICATIONS:

Technical Library: www.onsemi.com/design/resources/technical-documentation
onsemi Website: www.onsemi.com

ONLINE SUPPORT: www.onsemi.com/support

For additional information, please contact your local Sales Representative at www.onsemi.com/support/sales