

Intelligent Power Module (IPM)

Inverter, 1200 V, 15 A

NFAM1512L7B

General description

NFAM1512L7B is an advanced IPM module providing a fully-featured, high-performance inverter output stage for AC Induction, BLDC and PMSM motors. These modules integrate optimized gate drive of the built-in IGBTs to minimize EMI and losses, while also providing multiple on-module protection features including under-voltage lockouts, over-current shutdown, thermal monitoring of drive IC, and fault reporting. The built-in, high-speed HVIC requires only a single supply voltage and translates the incoming logic-level gate inputs to the high-voltage, high-current drive signals required to properly drive the module's internal IGBTs. Separate negative IGBT terminals are available for each phase to support the widest variety of control algorithms.

Features

- 1200 V 15 A 3-Phase FS7 IGBT Inverter, Including Control ICs for Gate Drive and Protections
- Very Low Thermal Resistance Using Al2O3 DBC Substrate
- Active Logic Interface
- Built-in Under-voltage Protection (UVP)
- Built-In Bootstrap Diodes/Resistors
- Separate Low-side IGBT Emitter Connections for Individual Current Sensing of Each Phase
- Temperature Sensor (TSU Output by LVIC)
- UL Certification: E209204
- This is a Pb-Free Device

Typical Application

- Industrial Drives
- Industrial Pumps
- Industrial Fans
- Industrial Automation

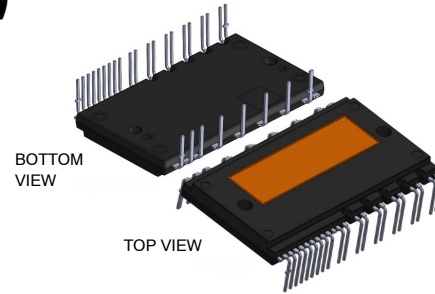

DIP39, 54.5x31.0 EP-2
CASE MODGX

MARKING DIAGRAM

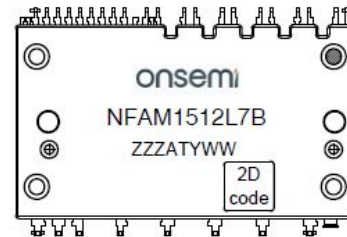

NFAM1512L7B = Specific Device Code
 ZZZ = Assembly Lot Code
 A = Assembly Location
 T = Test Location
 Y = Year
 WW = Work Week

ORDERING INFORMATION

Device	Package	Shipping
NFAM1512L7B	DIP39, 31.0x54.5 (Pb-Free)	90 / BOX

NFAM1512L7B

PIN CONFIGURATION

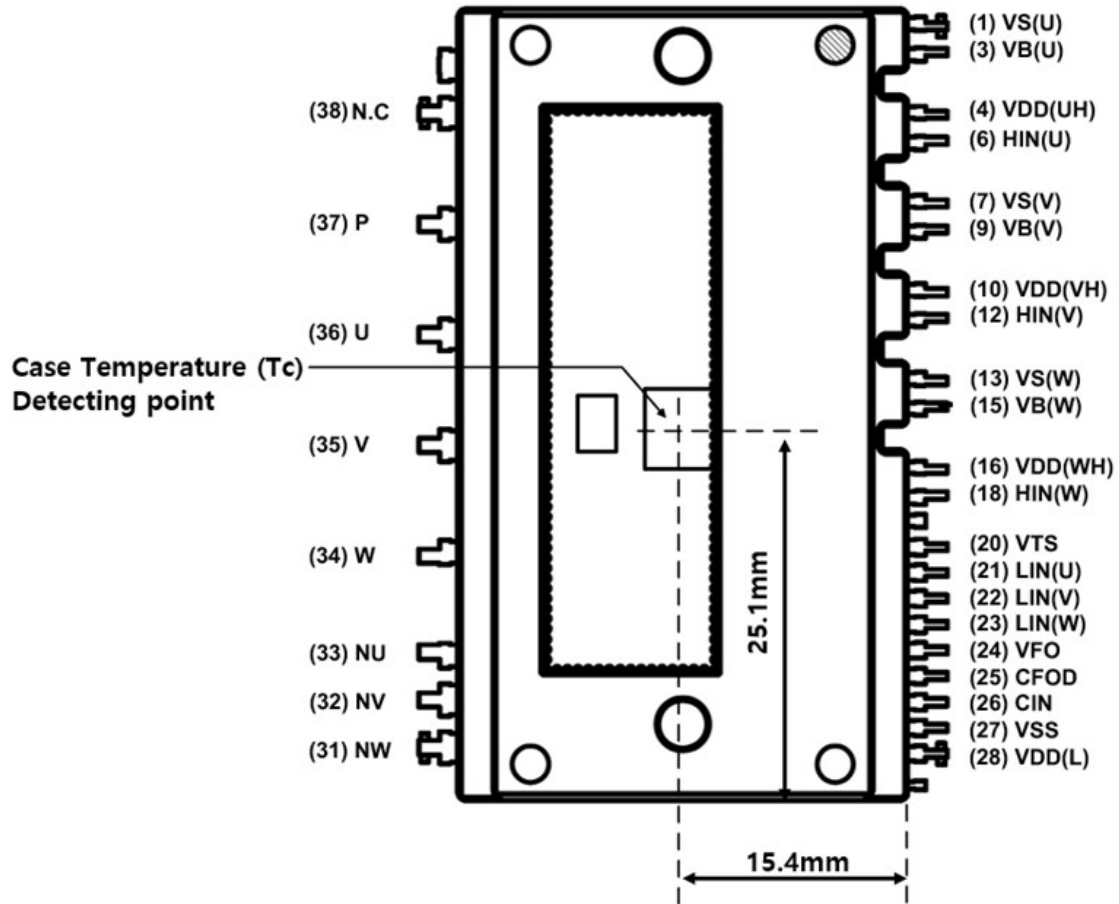

Figure 1. Pin Configuration – Top View

NFAM1512L7B

PIN DESCRIPTION

Pin	Name	Description
1	VS(U)	High-Side Bias Voltage Ground for U-Phase IGBT Driving
(2)	-	Dummy
3	VB(U)	High-Side Bias Voltage for U-Phase IGBT Driving
4	VDD(UH)	High-Side Bias Voltage for U-Phase IC
(5)	-	Dummy
6	HIN(U)	Signal Input for High-Side U-Phase
7	VS(V)	High-Side Bias Voltage Ground for V-Phase IGBT Driving
(8)	-	Dummy
9	VB(V)	High-Side Bias Voltage for V-Phase IGBT Driving
10	VDD(VH)	High-Side Bias Voltage for V-Phase IC
(11)	-	Dummy
12	HIN(V)	Signal Input for High-Side V-Phase
13	VS(W)	High-Side Bias Voltage Ground for W-Phase IGBT Driving
(14)	-	Dummy
15	VB(W)	High-Side Bias Voltage for W-Phase IGBT Driving
16	VDD(WH)	High-Side Bias Voltage for W-Phase IC
(17)	-	Dummy
18	HIN(W)	Signal Input for High-Side W-Phase
(19)	-	Dummy
20	VTS	Output for LVIC Temperature Sensing Voltage
21	LIN(U)	Signal Input for Low-Side U-Phase
22	LIN(V)	Signal Input for Low-Side V-Phase
23	LIN(W)	Signal Input for Low-Side W-Phase
24	VFO	Fault Output
25	CFOD	Capacitor for Fault Output Duration Selection
26	CIN	Input for Over Current Protection
27	VSS	Low-Side Common Supply Ground
28	VDD(L)	Low-Side Bias Voltage for IC and IGBTs Driving
(29)	-	Dummy
(30)	-	Dummy
31	NW	Negative DC-Link Input for W-Phase
32	NV	Negative DC-Link Input for V-Phase
33	NU	Negative DC-Link Input for U-Phase
34	W	Output for W-Phase
35	V	Output for V-Phase
36	U	Output for U-Phase
37	P	Positive DC-Link Input
38	N.C	No Connection
(39)	-	Dummy

NOTE: Pins of () are the dummy for internal connection. These pins should be no connection.

NFAM1512L7B

INTERNAL EQUIVALENT CIRCUIT AND INPUT/OUTPUT PINS

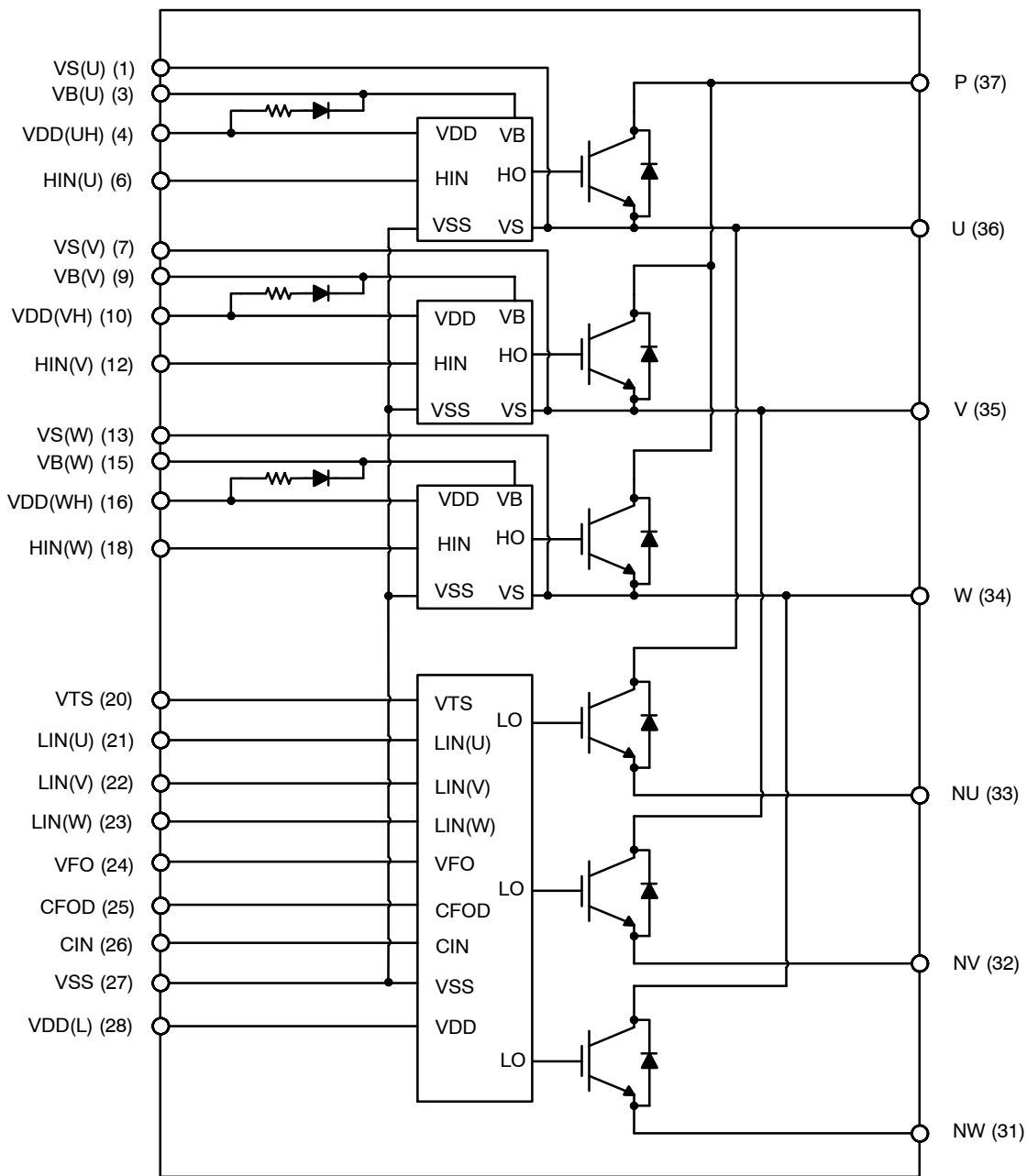

Figure 2. Internal Block Diagram

NFAM1512L7B

ABSOLUTE MAXIMUM RATINGS (VDD = 15 V and T_j = 25 °C, Unless Otherwise Specified)

Symbol	Rating	Conditions	Value	Unit
INVERTER PART				
VPN	Supply Voltage	Applied between P – NU, NV, NW	900	V
VPN(Surge)	Supply Voltage (Surge)	Applied between P – NU, NV, NW (Note 1)	1000	V
Vces	Collector – Emitter Voltage		1200	V
VRRM	Maximum Repetitive Revers Voltage		1200	V
±Ic	Each IGBT Collector Current		15	A
±Icp	Each IGBT Collector Current (Peak)	T _c = 25 °C, T _j ≤ 150 °C, under 1 ms Pulse Width	30	A
Pc	Corrector Dissipation	T _c = 25 °C per one chip (Note 2)	109	W
T _j	Operating Junction Temperature		-40 ~ 150	°C

CONTROL PART

VDD	Control Supply Voltage	Applied between VDD(H), VDD(L) – VSS	20	V
VBS	High-Side Control Bias Voltage	Applied between VB(U) – VS(U), VB(V) – VS(V), VB(W) – VS(W)	20	V
VIN	Input Signal Voltage	Applied between HIN(U), HIN(V), HIN(W), LIN(U), LIN(V), LIN(W) – VSS	-0.3 ~ VDD + 0.3	V
VFO	Fault Output Supply Voltage	Applied between VFO – VSS	-0.3 ~ VDD + 0.3	V
IFO	Fault Output Current	Sink Current at VFO pin	2	mA
VCIN	Current Sensing Input Voltage	Applied between CIN – VSS	-0.3 ~ VDD + 0.3	V

TOTAL SYSTEM

VPN(PROT)	Self-Protection Supply Voltage Limit (Short Circuit Protection Capability)	VDD = VBS = 13.5 ~ 16.5 V, T _j = 150 °C, Non-repetitive, <2 μs	800	V
T _c	Case Operation Temperature	See Figure 1	-40 ~ 125	°C
T _{stg}	Storage Temperature		-40 ~ 125	°C
Viso	Isolation Voltage	60 Hz, Sinusoidal, AC 1 minute, Connection Pins to Heat Sink Plate	2500	V _{rms}

Stresses exceeding those listed in the Maximum Ratings table may damage the device. If any of these limits are exceeded, device functionality should not be assumed, damage may occur and reliability may be affected.

- Surge voltage developed by the switching operation due to the wiring inductance between P and NU, NV, NW terminal.
- Calculation value considered to design factor.

THERMAL CHARACTERISTICS

Symbol	Rating	Conditions	Min	Typ	Max	Unit
R _{th(j-c)Q}	Junction to Case Thermal Resistance (Note 3)	Inverter IGBT Part (per 1/6 Module)	-	-	1.15	°C/W
R _{th(j-c)F}		Inverter FWDi Part (per 1/6 Module)	-	-	1.80	°C/W

- For the measurement point of case temperature (T_c), please refer to Figure 1.

NFAM1512L7B

ELECTRICAL CHARACTERISTICS (VDD = 15 V and Tj = 25 °C, Unless Otherwise Specified)

Symbol	Parameter	Test Conditions	Min	Typ	Max	Unit		
INVERTER PART								
Ices	Collector-Emitter Leakage Current	Tj = 25 °C, Vce = Vces	-	-	1	mA		
		Tj = 150 °C, Vce = Vces	-	-	10	mA		
VCE(sat)	Collector-Emitter Saturation Voltage	VDD = VBS = 15 V, Ic = 10 A, Tj = 25 °C	-	1.50	1.90	V		
		VDD = VBS = 15 V, Ic = 10 A, Tj = 150 °C	-	1.75	-	V		
VF	FWDi Forward Voltage	VIN = 0 V, IF = 10 A, Tj = 25 °C	-	1.70	2.10	V		
		VIN = 0 V, IF = 10 A, Tj = 150 °C	-	1.65	-	V		
HS	ton	High Side Switching Times VPN = 600 V, VDD = 15 V, Ic = 10 A, Tj = 25 °C, Inductive Load Switching See Figures 3, 23, 24 (Note 4)	1.00	1.30	1.90	μs		
			tc (on)	-	0.15	0.55	μs	
			toff	-	1.50	2.00	μs	
			tc (off)	-	0.27	0.30	μs	
			trr	-	0.26	-	μs	
LS	ton		Low Side Switching Times	1.00	1.45	1.90	μs	
				tc (on)	-	0.17	0.55	μs
				toff	-	1.65	2.00	μs
				tc (off)	-	0.24	0.30	μs
				trr	-	0.25	-	μs

CONTROL PART

IQDDH	Quiescent VDD Supply Current	VDD(UH,VH,WH) = 15 V, HIN(U,V,W) = 0 V	VDD(UH) - VSS VDD(VH) - VSS VDD(WH) - VSS	-	-	0.30	mA
IQDDL		VDD(L) = 15 V, LIN(U, V, W) = 0 V	VDD(L) - VSS	-	-	2.00	mA
IPDDH	Operating VDD Supply Current	VDD(UH, VH, WH) = 15 V, fPWM = 20 kHz, Duty = 50%, applied to one PWM Signal Input for High-Side	VDD(UH) - VSS VDD(VH) - VSS VDD(WH) - VSS	-	-	0.40	mA
IPDDL		VDD(L) = 15 V, fPWM = 20 kHz, Duty = 50%, applied to one PWM Signal Input for Low-Side	VDD(L) - VSS	-	-	5.00	mA
IQBS	Quiescent VBS Supply Current	VBS(U, V, W) = 15 V HIN(U, V, W) = 0 V	VB(U) - VS(U) VB(V) - VS(V) VB(W) - VS(W)	-	-	0.30	mA
IPBS	Operating VBS Supply Current	VDD(UH, VH, WH) = VBS = 15 V, fPWM = 20 kHz, Duty = 50%, Applied to one PWM Signal Input for High-Side	VB(U) - VS(U) VB(V) - VS(V) VB(W) - VS(W)	-	-	3.50	mA
VIN(ON)	ON Threshold Voltage	HIN(U, V, W) - VSS, LIN(U, V, W) - VSS		-	-	2.60	V
VIN(OFF)	OFF Threshold Voltage			0.80	-	-	V
VCIN(ref)	Over Current Trip Level	VDD = 15 V	CIN-VSS	0.46	0.48	0.50	V
UVDDD	Supply Circuit Under-Voltage Protection	Detection Level		10.30	-	12.50	V
UVDDR		Reset Level		10.80	-	13.00	V
UVBSD		Detection Level		10.00	-	12.00	V
UVBSR		Reset Level		10.50	-	12.50	V
VTS	Voltage Output for LVIC Temperature Sensing Unit	VTS-VSS = 5.1 kΩ, Temp. = 25 °C (Note 5)		1.145	1.25	1.38	V

NFAM1512L7B

ELECTRICAL CHARACTERISTICS (VDD = 15 V and Tj = 25 °C, Unless Otherwise Specified) (continued)

Symbol	Parameter	Test Conditions	Min	Typ	Max	Unit
CONTROL PART						
VFOH	Fault Output Voltage	VDD(L) = 0 V, CIN = 0 V, VFO Circuit: 10 kΩ to 5 V Pull-up	4.90	-	-	V
VFOL		VDD(L) = 0 V, CIN = 1 V, VFO Circuit: 10 kΩ to 5 V Pull-up	-	-	0.95	V
tFOD	Fault-Output Pulse Width	CFOD = 22 nF (Note 6)	1.60	2.40	-	ms
BOOTSTRAP PART						
VF	Bootstrap Diode Forward Current	If = 0.1 A (See Figure 6)	2.10	2.50	2.90	V
RBOOT	Built-in Limiting Resistance		12.50	15.50	18.50	Ω

Product parametric performance is indicated in the Electrical Characteristics for the listed test conditions, unless otherwise noted. Product performance may not be indicated by the Electrical Characteristics if operated under different conditions.

Performance guaranteed over the indicated operating temperature range by design and/or characterization tested at Tj = Ta = 25 °C. Low duty cycle pulse techniques are used during testing to maintain the junction temperature as close to ambient as possible. Values based on design and/or characterization.

- ton and toff include the propagation delay of the internal drive IC. tc(on) and tc(off) are the switching times of IGBT under the given gate-driving condition internally. For the detailed information, please see *Figure 3*.
- TLVIC is the temperature of LVIC itself. VTS is only for sensing temperature of LVIC and cannot shutdown IGBTs automatically. The relationship between VTS voltage output and LVIC temperature is described in *Figure 4*. It is recommended to add 5.1 kΩ pull down resistor between VTS and VSS (Signal Ground) as described in *Figure 5* for linear output characteristics at low temperature. Refer to the application note for usage of VTS.
- The fault-out pulse width tFOD depends on the capacitance value of CFOD according to the following approximate equation:

$$tFOD = 0.11 \times 10^6 \times CFOD [s].$$

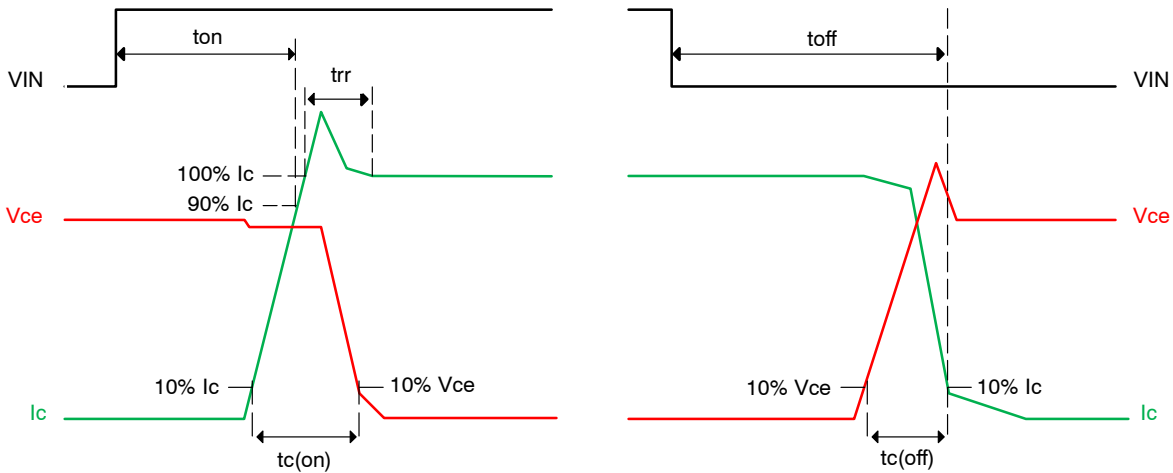

Figure 3. Switching Time Definitions

NFAM1512L7B

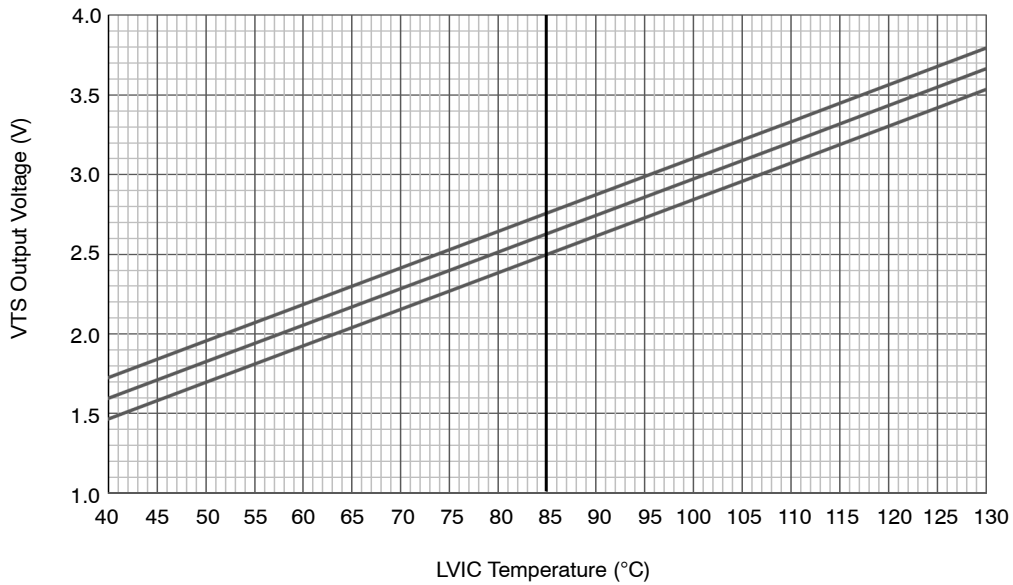

Figure 4. Temperature of LVIC vs. VTS Characteristics

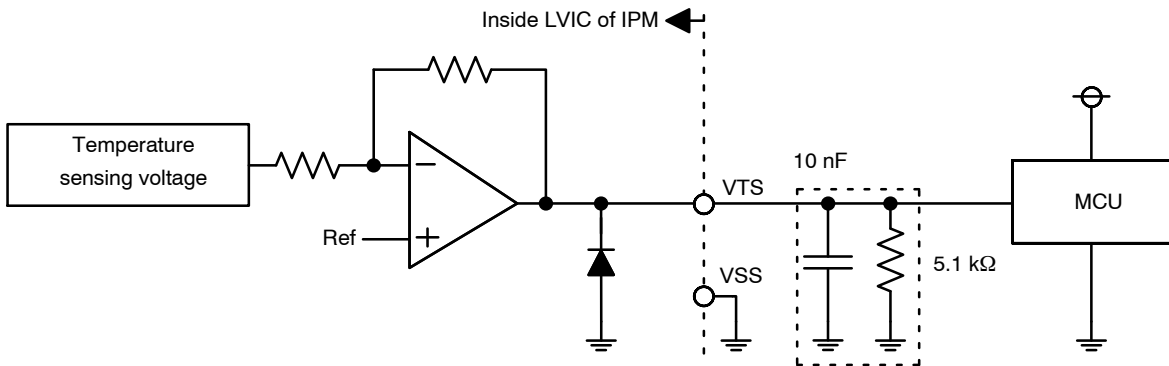

Figure 5. Internal Block Diagram and Interface Circuit of VTS

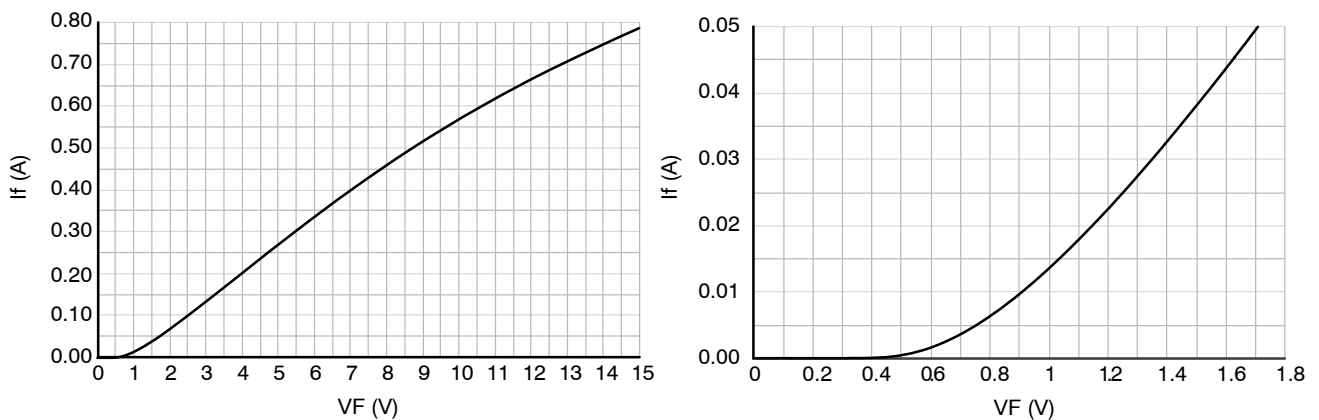

Figure 6. Characteristics of Bootstrap Diode/Resistor (Right Figure is Enlarged Figure)

NFAM1512L7B

RECOMMENDED OPERATING CONDITIONS

Symbol	Description	Conditions	Value			Unit	
			Min	Typ	Max		
VPN	Supply Voltage	Applied between P – NU, NV, NW	–	600	800	V	
VDD	Control Supply Voltage	Applied between VDD(H) – VSS, VDD(L) – VSS	13.5	15	16.5	V	
VBS	High-Side Bias Voltage	Applied between VB(U) – VS(U), VB(V) – VS(V), VB(W) – VS(W)	13.0	15	18.5	V	
dVDD / dt, dVBS / dt	Control Supply Variation		–1	–	1	V/ μ s	
Tdead	Blanking Time for Preventing Arm – Short	For Each Input Signal	1	–	–	μ s	
fPWM	PWM Input Signal	$-40\text{ }^{\circ}\text{C} \leq T_c \leq 125\text{ }^{\circ}\text{C}$, $-40\text{ }^{\circ}\text{C} \leq T_j \leq 150\text{ }^{\circ}\text{C}$	1	–	20	kHz	
I _o	Allowable r.m.s. Current	VPN = 600 V, VDD = VBS = 15 V, P.F. = 0.8, T _c \leq 125 $^{\circ}$ C, T _j \leq 150 $^{\circ}$ C (Note 7)	fPWM = 5 kHz	–	–	15.3	Arms
			fPWM = 15 kHz	–	–	9.5	Arms
PWIN(ON)	Minimum Input Pulse Width	VDD = VBS = 15 V, Wiring Inductance between NU, V, W and DC Link N < 10 nH (Note 8)	1.0	–	–	μ s	
PWIN(OFF)			2.0	–	–		
Package Mounting Torque		M3 Type Screw	0.6	0.7	0.9	Nm	

Functional operation above the stresses listed in the Recommended Operating Ranges is not implied. Extended exposure to stresses beyond the Recommended Operating Ranges limits may affect device reliability.

Flatness tolerance of the heatsink should be within $-50\text{ }\mu\text{m}$ to $+100\text{ }\mu\text{m}$.

- Allowable output current value is the reference data for the safe operation of this product. This may be different from the actual application and operating condition.
- Product might not make response if input pulse width is less than the recommended value.

TIME CHARTS OF PROTECTIVE FUNCTION

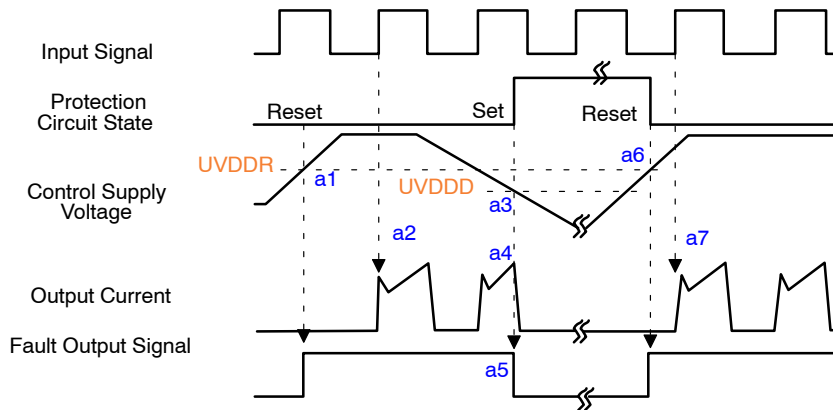

- a1: Control supply voltage rises: After the voltage rises UVDDR, the circuits start to operate when next input is applied.
a2: Normal operation: IGBT ON and carrying current.
a3: Under voltage detection (UVDDD).
a4: IGBT OFF in spite of control input condition.
a5: Fault output operation starts with a fixed pulse width. a6 : Under voltage reset (UVDDR).
a7: Normal operation: IGBT ON and carrying current by triggering next signal from LOW to HIGH.

Figure 7. Under-Voltage Protection (Low-Side)

NFAM1512L7B

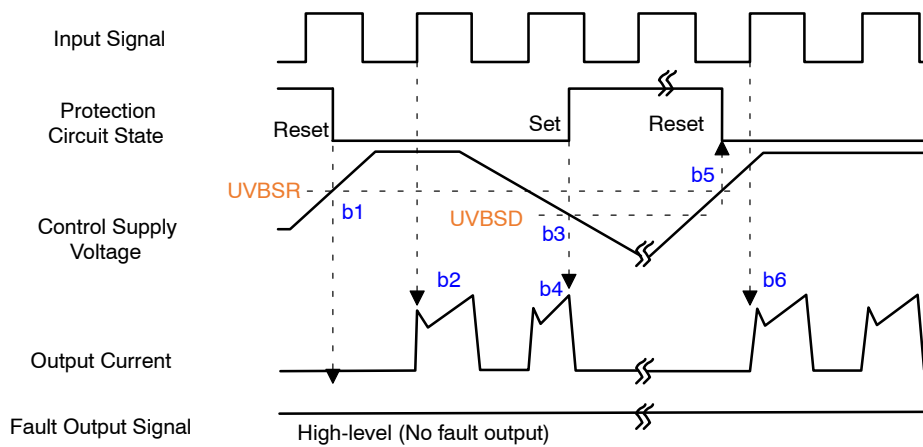

- b1 : Control supply voltage rises: After the voltage reaches UVBSR, the circuits start to operate when next input is applied.
- b2 : Normal operation: IGBT ON and carrying current.
- b3 : Under voltage detection (UVBSD).
- b4 : IGBT OFF in spite of control input condition, but there is no fault output signal.
- b5 : Under voltage reset (UVBSR).
- b6 : Normal operation: IGBT ON and carrying current by triggering next signal from LOW to HIGH.

Figure 8. Under-Voltage Protection (High-Side)

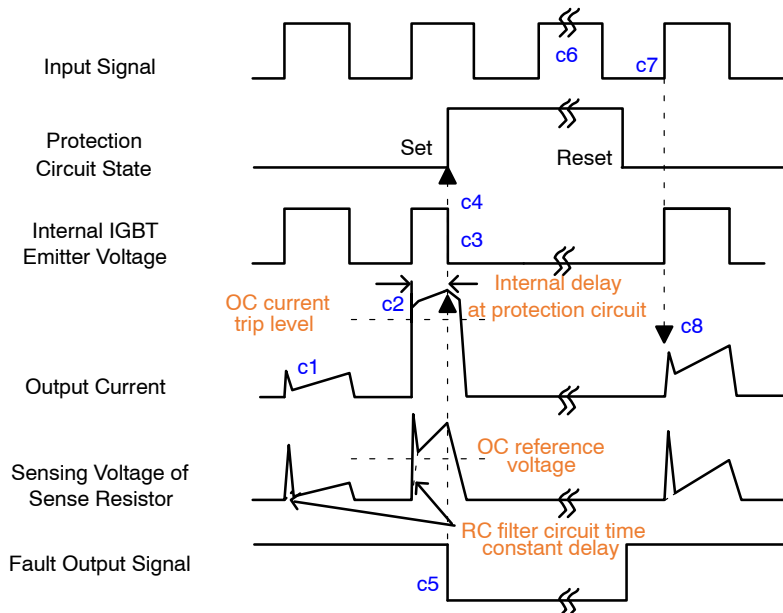

(with the external sense resistance and RC filter connection)

- c1 : Normal operation: IGBT ON and carrying current.
- c2 : Over current detection (OC trigger).
- c3 : All low-side IGBT's gate are hard interrupted.
- c4 : All low-side IGBTs turn OFF.
- c5 : Fault output operation starts with a fixed pulse width.
- c6 : Input HIGH: IGBT ON state, but during the active period of fault output the IGBT doesn't turn ON.
- c7 : Fault output operation finishes, but IGBT doesn't turn on until triggering next signal from LOW to HIGH.
- c8 : Normal operation: IGBT ON and carrying current.

Figure 9. Over Current Protection (Low-Side Operation only)

TYPICAL CHARACTERISTICS

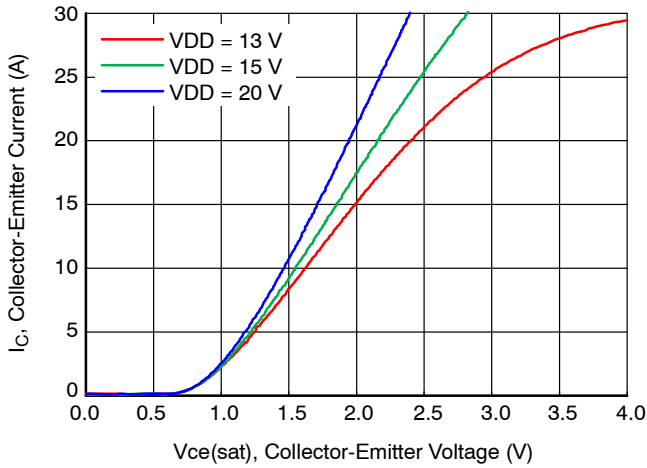

Figure 11. Typ. Collector-Emitter Saturation Voltage

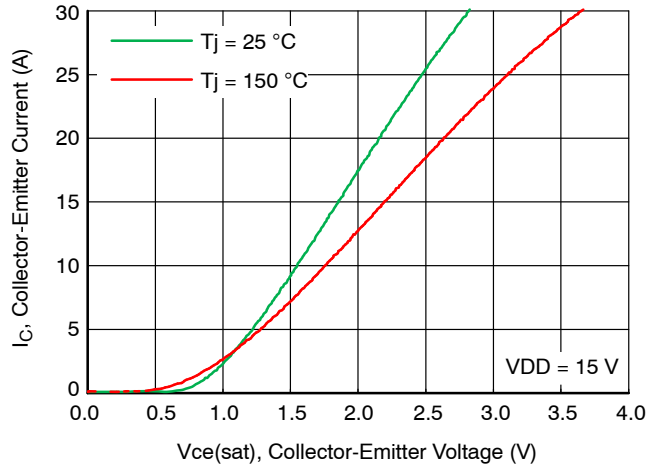

Figure 12. Typ. Collector-Emitter Saturation Voltage

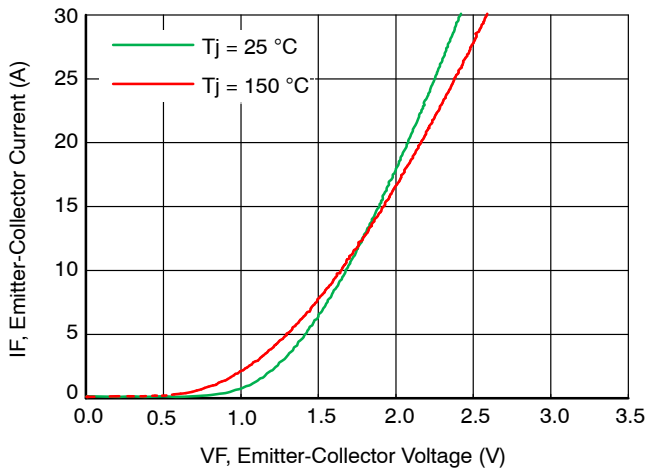

Figure 13. Typ. Emitter-Collector Forward Voltage

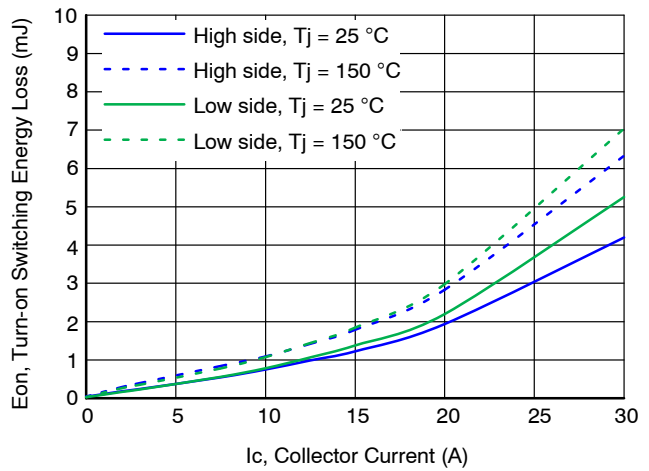

Figure 14. Typ. Turn-on Switching Energy Loss

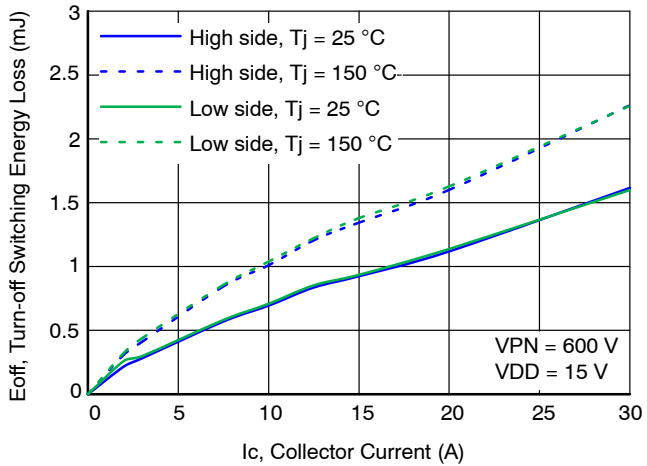

Figure 15. Typ. Turn-off Switching Energy Loss

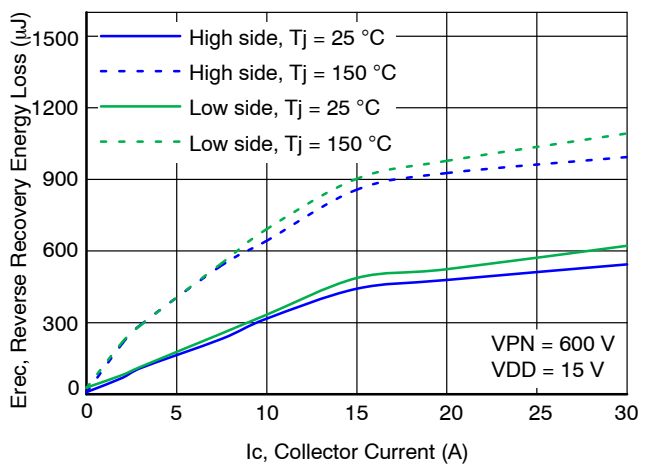

Figure 16. Typ. Reverse Recovery Energy Loss

TYPICAL CHARACTERISTICS (CONTINUED)

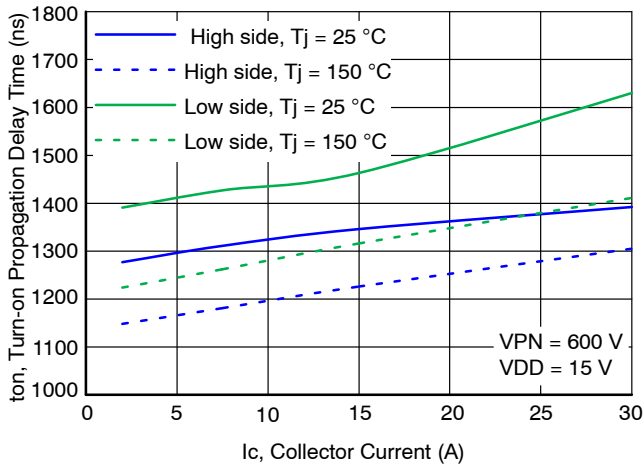

Figure 17. Typ. Turn-on Propagation Delay Time

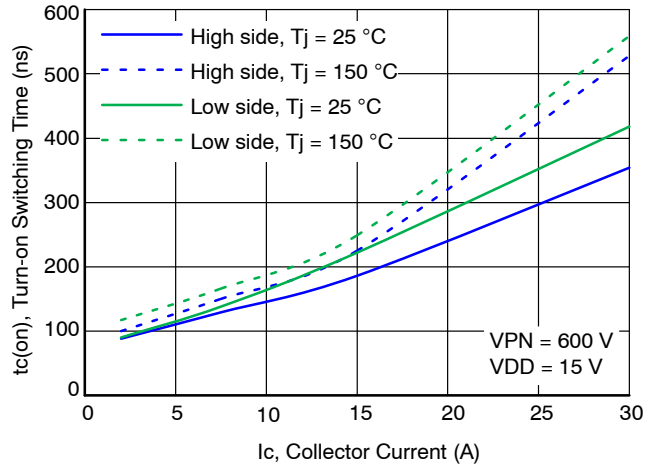

Figure 18. Typ. Turn-on Switching Time

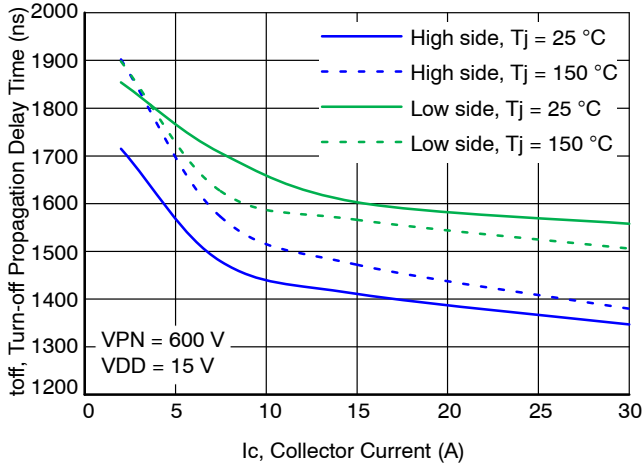

Figure 19. Typ. Turn-off Propagation Delay Time

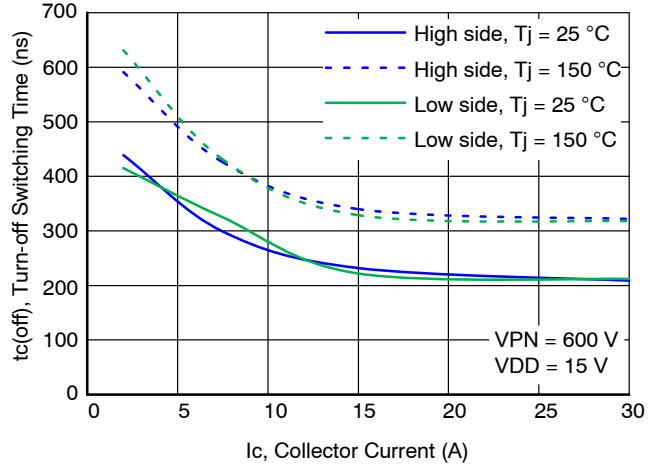

Figure 20. Typ. Turn-off Switching Time

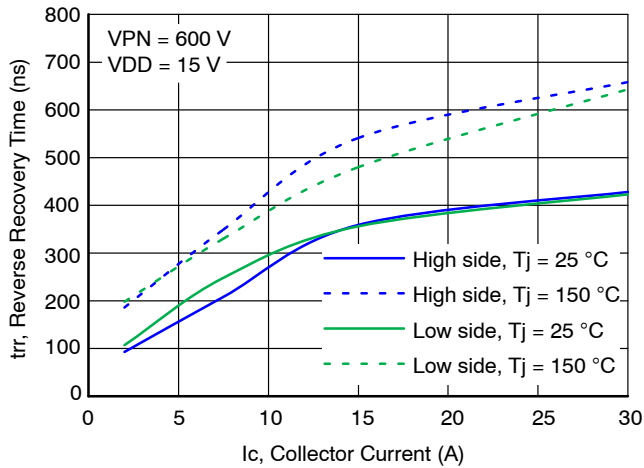

Figure 21. Typ. Reverse Recovery Time

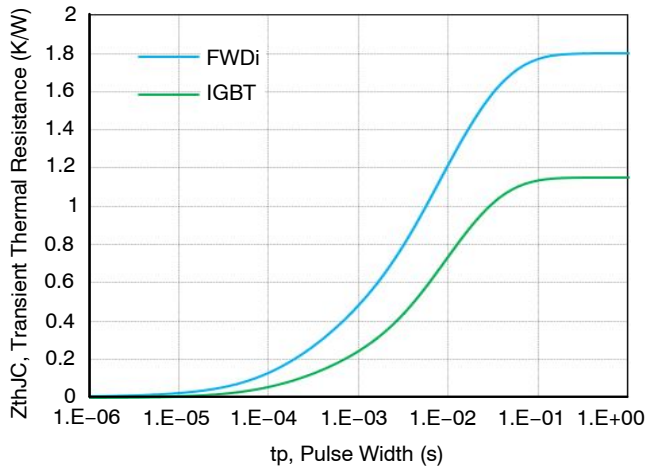

Figure 22. Transient Thermal Resistance

NFAM1512L7B

TURN-ON/OFF SWITCHING WAVEFORM

SWITCHING CONDITION: VDC = 600 V, VDD = 15 V, T_J = 25 °C, I_C = 10 A.

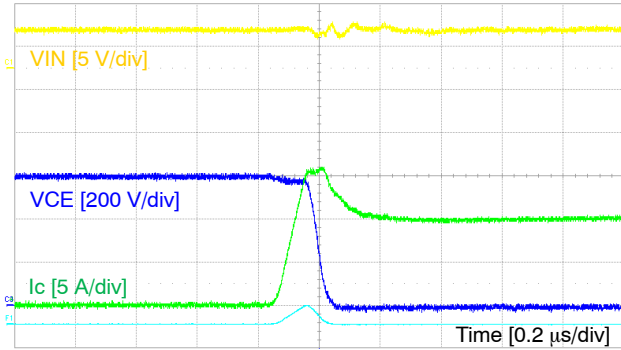

Figure 23. Turn-on Switching Waveform

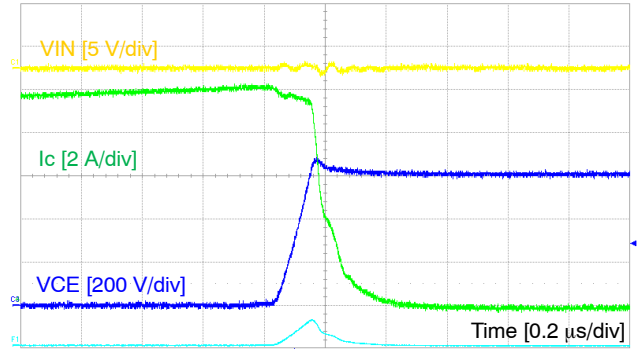

Figure 24. Turn-off Switching Waveform

NFAM1512L7B

REVISION HISTORY

Revision	Description of Changes	Date
4	Updated MIN limit spec of VTS item in the Electrical Characteristics Table (CONTROL PART SECTION) on page 6.	7/1/2025

This document has undergone updates prior to the inclusion of this revision history table. The changes tracked here only reflect updates made on the noted approval dates.

**DIP-39, 54.50x31.00x5.60, 1.78P EP-2
CASE MODGX
ISSUE C**

DATE 08 JUN 2026

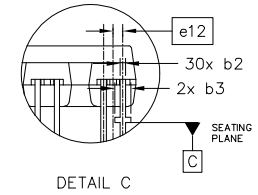
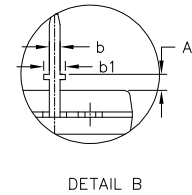
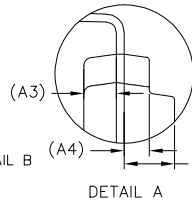
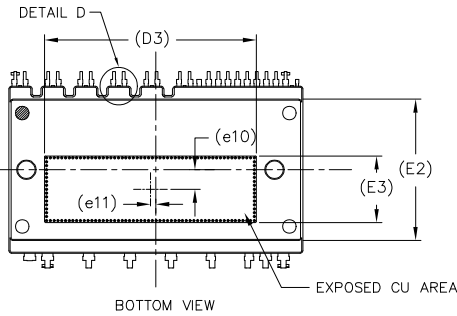
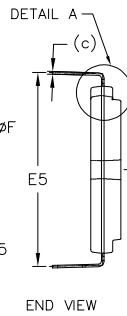
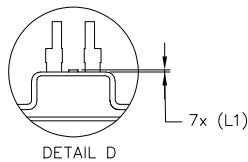
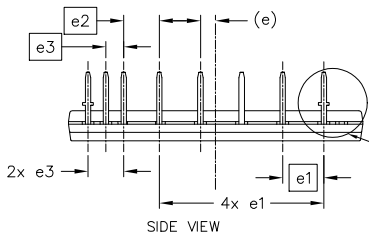
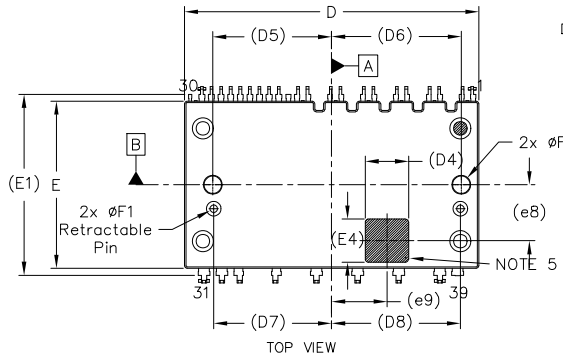
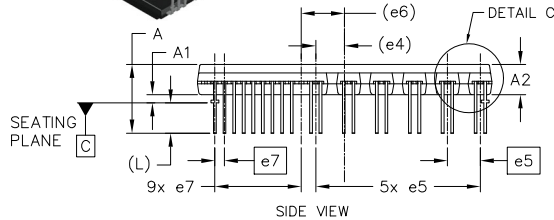
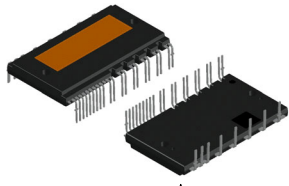

- NOTES:
1. DIMENSIONING AND TOLERANCING PER ASME Y14.5M, 2009.
 2. CONTROLLING DIMENSION: MILLIMETERS
 3. DIMENSION b and c APPLY TO THE PLATED LEADS AND ARE MEASURED BETWEEN 1.00 AND 2.00 FROM THE LEAD TIP
 4. POSITION OF THE LEAD IS DETERMINED AT THE BASE OF THE LEAD WHERE IT EXITS THE PACKAGE BODY
 5. AREA FOR 2D BAR CODE
 6. SHORTENED/CUT PINS ARE 2,5,8,11,14,17,19,29, 30 AND 39
 7. DIMENSIONS "D" AND "E" DO NOT INCLUDE THE SIDE FLASH PROTRUSION WHICH IS ~0.12 FOR EACH SIDE

GENERIC MARKING DIAGRAM*

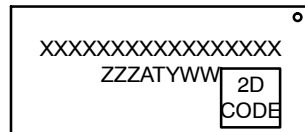

XXXXX = Specific Device Code
 ZZZ = Assembly Lot Code
 AT = Assembly & Test Location
 Y = Year
 WW = Work Week

*This information is generic. Please refer to device data sheet for actual part marking. Pb-Free indicator, "G" or microdot "µ", may or may not be present. Some products may not follow the Generic Marking.

DIM	MILLIMETERS		
	MIN.	NOM.	MAX.
A	12.20	12.7	13.2
A1	1.00	1.50	2.00
A2	5.50	5.60	5.70
A3	2.00 REF		
A4	1.55 REF		
A5	3.10 REF		
b	0.90	1.00	1.10
b1	1.90	2.00	2.10
b2	0.40	0.50	0.60
b3	1.40	1.50	1.60
c	0.50 REF		
D	54.40	54.50	54.60
D3	39.25 REF		
D4	8.00 REF		
D5	22.00 REF		
D6	24.00 REF		
D7	21.85 REF		
D8	23.85 REF		

DIM	MILLIMETERS		
	MIN.	NOM.	MAX.
E	30.90	31.00	31.10
E1	33.50 REF		
E2	26.14 REF		
E3	12.35 REF		
E4	8.00 REF		
E5	35.40	35.90	36.40
e	2.81 REF		
e1	7.62 BSC		
e2	6.60 BSC		
e3	3.30 BSC		
e4	5.35 REF		
e5	6.10 BSC		
e6	8.02 REF		
e7	1.78 BSC		
e8	10.35 REF		
e9	10.25 REF		
e10	3.60 REF		
e11	1.00 REF		
e12	0.89 BSC		
F	3.20	3.30	3.40
F1	1.40	1.50	1.60
L	5.60 REF		
L1	0.10 REF		

DOCUMENT NUMBER:	98AON05290H	Electronic versions are uncontrolled except when accessed directly from the Document Repository. Printed versions are uncontrolled except when stamped "CONTROLLED COPY" in red.
DESCRIPTION:	DIP-39, 54.50x31.00x5.60, 1.78P EP-2	PAGE 1 OF 1

onsemi and ONSEMI are trademarks of Semiconductor Components Industries, LLC dba onsemi or its subsidiaries in the United States and/or other countries. onsemi reserves the right to make changes without further notice to any products herein. onsemi makes no warranty, representation or guarantee regarding the suitability of its products for any particular purpose, nor does onsemi assume any liability arising out of the application or use of any product or circuit, and specifically disclaims any and all liability, including without limitation special, consequential or incidental damages. onsemi does not convey any license under its patent rights nor the rights of others.

onsemi, **Onsemi**, and other names, marks, and brands are registered and/or common law trademarks of Semiconductor Components Industries, LLC dba "**onsemi**" or its affiliates and/or subsidiaries in the United States and/or other countries. **onsemi** owns the rights to a number of patents, trademarks, copyrights, trade secrets, and other intellectual property. A listing of **onsemi**'s product/patent coverage may be accessed at www.onsemi.com/site/pdf/Patent-Marking.pdf. **onsemi** reserves the right to make changes at any time to any products or information herein, without notice. The information herein is provided "as-is" and **onsemi** makes no warranty, representation or guarantee regarding the accuracy of the information, product features, availability, functionality, or suitability of its products for any particular purpose, nor does **onsemi** assume any liability arising out of the application or use of any product or circuit, and specifically disclaims any and all liability, including without limitation special, consequential or incidental damages. Buyer is responsible for its products and applications using **onsemi** products, including compliance with all laws, regulations and safety requirements or standards, regardless of any support or applications information provided by **onsemi**. "Typical" parameters which may be provided in **onsemi** data sheets and/or specifications can and do vary in different applications and actual performance may vary over time. All operating parameters, including "Typicals" must be validated for each customer application by customer's technical experts. **onsemi** does not convey any license under any of its intellectual property rights nor the rights of others. **onsemi** products are not designed, intended, or authorized for use as a critical component in life support systems or any FDA Class 3 medical devices or medical devices with a same or similar classification in a foreign jurisdiction or any devices intended for implantation in the human body. Should Buyer purchase or use **onsemi** products for any such unintended or unauthorized application, Buyer shall indemnify and hold **onsemi** and its officers, employees, subsidiaries, affiliates, and distributors harmless against all claims, costs, damages, and expenses, and reasonable attorney fees arising out of, directly or indirectly, any claim of personal injury or death associated with such unintended or unauthorized use, even if such claim alleges that **onsemi** was negligent regarding the design or manufacture of the part. **onsemi** is an Equal Opportunity/Affirmative Action Employer. This literature is subject to all applicable copyright laws and is not for resale in any manner.

ADDITIONAL INFORMATION

TECHNICAL PUBLICATIONS:

Technical Library: www.onsemi.com/design/resources/technical-documentation
onsemi Website: www.onsemi.com

ONLINE SUPPORT: www.onsemi.com/support

For additional information, please contact your local Sales Representative at www.onsemi.com/support/sales