

3.75 kV_{RMS}, 4.5-A/9-A Isolated Single Channel Gate Driver

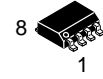

SOIC-8 NB
CASE 751-07

NCP51152

The NCP51152 is a family of isolated single-channel gate driver with 4.5-A/9-A source and sink peak current respectively. They are designed for fast switching to drive power MOSFETs, and SiC MOSFET power switches. The NCP51152 offers short and matched propagation delays. The NCP51152xA provides a split output that controls the rise and fall times individually. The NCP51152xB has its V_{CC} UVLO referenced to GND2 to get a true UVLO.

The NCP51152 is available in a 4 mm SOIC-8 package and can support isolation voltage up to 3.75 kV_{RMS}.

The NCP51152 offers other important protection function such as independent under-voltage lockout for both-side driver.

Features

- Feature Options
 - ◆ Separated Outputs (NCP51152xA)
 - ◆ Wide Bias Voltage Range Including Negative V_{EE} and V_{CC} UVLO Referenced to GND2 (NCP51152xB)
- 3-V to 20-V Input Supply Voltage
- Output Supply Voltage from 6.5 V to 30 V with 5-V and 8-V for MOSFET, 12-V and 17-V for SiC, Threshold
- 4.5-A Peak Source, 9-A Peak Sink Output Current Capability
- 200 V/ns dV/dt Immunity
- Negative 5-V Handling Capability on Input Pins
- Propagation Delay Typical 36 ns with
 - ◆ 5 ns Max Delay Matching
- Gate Clamping During Short Circuit (NCP51152xA)
- Isolation & Safety
 - ◆ 3.75 kV_{RMS} Isolation for 1 Minute (per UL1577 Requirements) (Planned)
 - ◆ CQC Certification per GB4943.1-2011 (Planned)
 - ◆ SGS FIMO Certification per IEC 62386-1 (Planned)

Typical Applications

- Motor Drives
- Isolated Converters in DC-DC and AC-DC Power Supply
- Server, Telecom, and Industrial Infrastructure

MARKING DIAGRAM

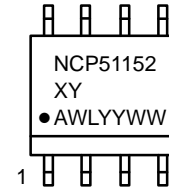

- NCP51152 = Specific Device Code
 X = A or B or C or D for UVLO Option
 Y = A: Split Output, or B: V_{EE}_GND2 for True UVLO
 A = Assembly Location
 WL = Wafer Lot
 YY = Year
 WW = Work Week

PIN CONNECTIONS

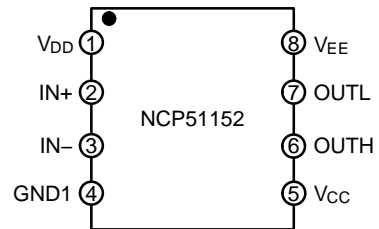

NCP51152xA

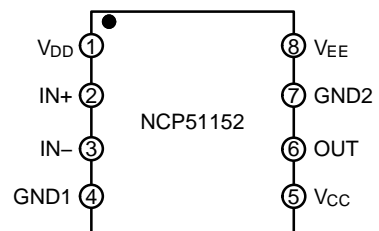

NCP51152xB

ORDERING INFORMATION

See detailed ordering and shipping information on page 22 of this data sheet.

NCP51152

FUNCTIONAL BLOCK DIAGRAM

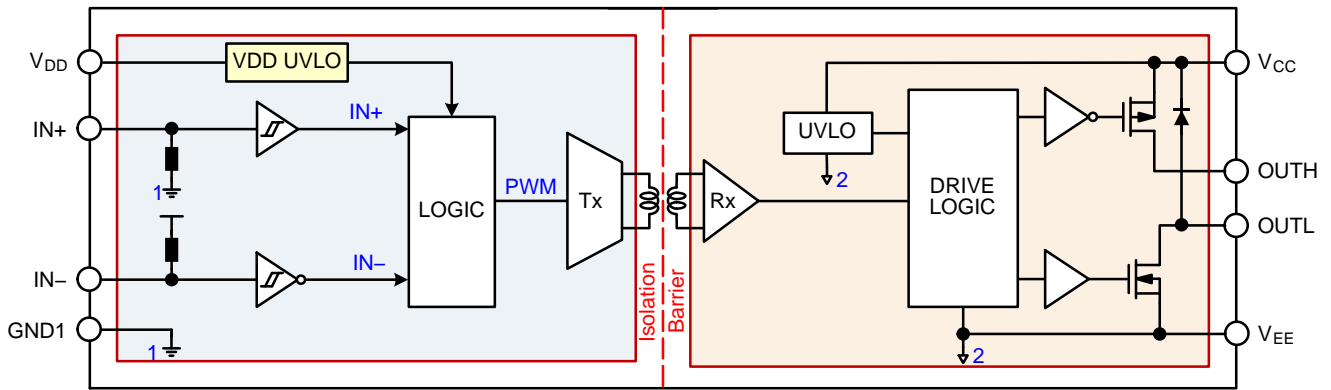

(a) Separated Output (Variant A)

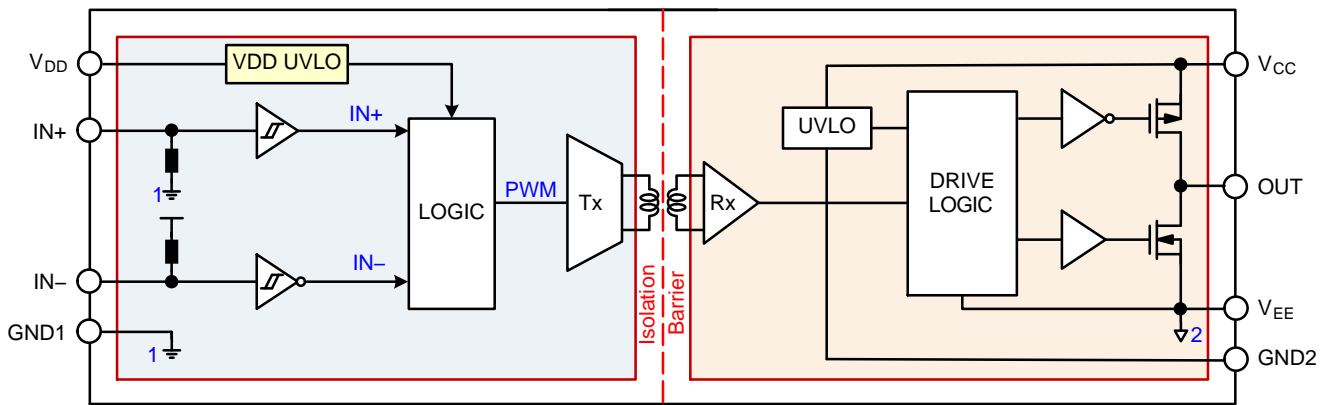

(b) V_{CC} UVLO Referenced to GND2 and external negative bias (Variant B)

Figure 2. Simplified Block Diagram

NCP51152

PIN CONNECTIONS

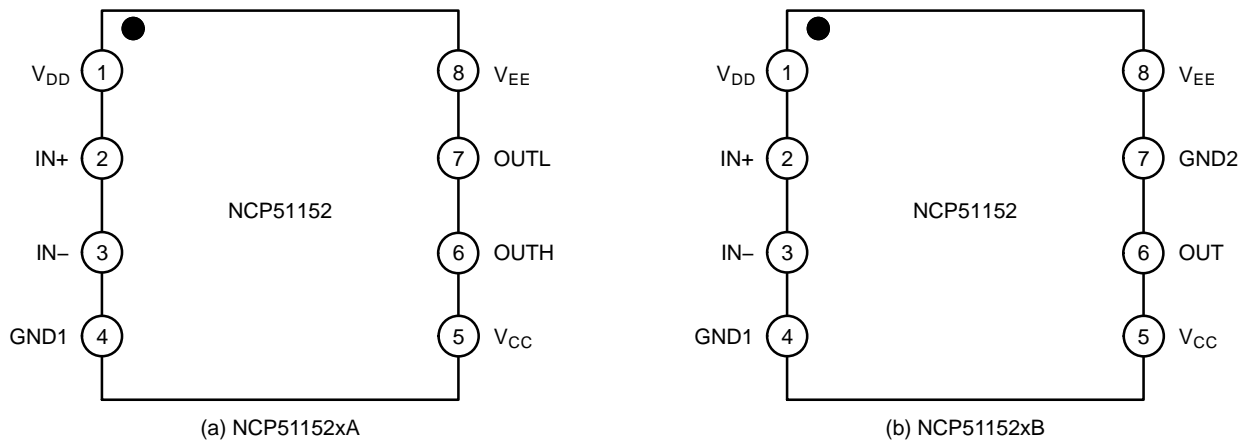

Figure 3. Pin Connections – SOIC–8 NB (Top View)

PIN DESCRIPTION

Pin Name	Pin No.		I/O	Description
	NCP51152xA	NCP51152xB		
V _{DD}	1	1	Power	Input-side Supply Voltage. It is recommended to place a bypass capacitor from V _{DD} to GND1.
IN+	2	2	Input	Non-inverting Logic Input with internal pull-down resistor to GND1.
IN-	3	3	Input	Inverting Logic Input with internal pull-up resistor to V _{DD} .
GND1	4	4	Power	Ground Input-side. (all signals on input-side are referenced to this ground)
V _{CC}	5	5	Power	Positive Output Supply Rail.
OUTH	6	6	Output	Gate Drive Pull-up Output.
OUTL	7	–	Output	Gate Drive Pull-down Output.
GND2	–	7	Power	Gate-drive common pin. Connect this pin to the MOSFET source. V _{CC} UVLO with respect to GND2 for variant B.
V _{EE}	8	8	Power	Negative output supply rail for variant B, and ground for variant A.

NCP51152

INSULATION RATINGS

Symbol	Parameter	Value	Unit
	Installation Classifications per DIN VDE 0110/1.89 Table 1 Rated Mains Voltage	<150 V _{RMS}	I-IV
		<300 V _{RMS}	I-IV
		<450 V _{RMS}	I-IV
		<600 V _{RMS}	I-IV
		<1000 V _{RMS}	I-III
CTI	Comparative Tracking Index (DIN IEC 112/VDE 0303 Part 1)	600	
	Climatic Classification	40/125/21	
	Pollution Degree (DIN VDE 0110/1.89)	2	
V _{PR}	Input-to-Output Test Voltage, Method b, V _{IORM} × 1.875 = V _{PR} , 100% Production Test with t _m = 1 s, Partial Discharge < 5 pC	2250	V _{PK}
V _{IORM}	Maximum Repetitive Peak Isolation Voltage	1200	V _{PK}
V _{IOWM}	Maximum Working Voltage	870	V _{RMS}
V _{IOTM}	Maximum Transient Isolation Voltage	6300	V _{PK}
E _{CR}	External Creepage	4.0	mm
E _{CL}	External Clearance	4.0	mm
DTI	Insulation Thickness	17.3	μm
R _{IO}	Insulation Resistance at T _S , V _{IO} = 500 V	10 ⁹	Ω

SAFETY LIMITING VALUE

Symbol	Parameter	Test Condition	Side	Value	Unit
P _S	Safety Supply Power	R _{θJA} = 120°C/W, T _A = 25°C, T _J = 150°C	INPUT	0.21	W
			OUTPUT	1.04	W
			TOTAL	1.25	W
T _S	Safety Temperature			150	°C

MAXIMUM RATINGS

Symbol	Parameter	Min	Max	Unit	
V _{DD} to GND1	Power Supply Voltage – Input Side (Note 2)	-0.3	25	V	
V _{CC} – GND2	Positive Supply Voltage – Driver Side	-0.3	33	V	
VEE – GND2	Negative Supply Voltage for Only B Version	-18	0.3	V	
V _{CC} – VEE	Differential Supply Voltage – Driver Side (Note 3)	-0.3	33	V	
OUT to VEE	Driver Output Voltage (Note 3)	V _{EE} – 0.3	V _{CC} + 0.3	V	
OUT to VEE, Transient for 200 ns (Note 4)		V _{EE} – 2	V _{CC} + 0.3	V	
IN+, and IN-	Input Signal Voltages (Note 2)	-5	V _{DD} + 0.3	V	
T _J	Junction Temperature	-40	+150	°C	
T _S	Storage Temperature	-65	+150	°C	
Electrostatic Discharge Capability	HBM (Note 5)	Human Body Model	-	2	kV
	CDM (Note 5)	Charged Device Model	-	1	kV

Stresses exceeding those listed in the Maximum Ratings table may damage the device. If any of these limits are exceeded, device functionality should not be assumed, damage may occur and reliability may be affected.

1. Refer to ELECTRICAL CHARACTERISTICS, RECOMMENDED OPERATING RANGES and/or APPLICATION INFORMATION for Safe Operating parameters.
2. All voltage values are given with respect to GND1 pin.
3. All voltage values are given with respect to VEE pin.
4. This parameter verified by design and bench test, not tested in production.
5. This device series incorporates ESD protection and is tested by the following methods:
 ESD Human Body Model tested per AEC-Q100-002 (EIA/JESD22-A114)
 ESD Charged Device Model tested per AEC-Q100-011 (EIA/JESD22-C101)
 Latch up Current Maximum Rating: ≤100 mA per JEDEC standard: JESD78F.

THERMAL CHARACTERISTICS

Symbol	Parameter	Min	Max	Unit
θ_{JA}	Secondary Thermal Resistance of Junction–Air (Note 6)	Type–A (Note 7)	100	$^{\circ}\text{C}/\text{W}$
		Type–B (Note 8)	120	
θ_{JT}	Thermal Characterization Parameter Junction–Case Top	Type–A (Note 7)	8	
		Type–B (Note 8)	8	
P_D	Secondary Power Dissipation (Note 6)	Type–A (Note 7)	1.25	W
		Type–B (Note 8)	1.04	

6. Refer to ELECTRICAL CHARACTERISTICS, RECOMMENDED OPERATING RANGES and/or APPLICATION INFORMATION for Safe Operating parameters.

7. As specified for a reference layout shown in Figure 4. The DUT is mounted on a 60 x 40 x 1.6 mm FR4 substrate with an additional heat spreading copper of 240 mm²/300 mm² (Primary/Secondary). The copper thickness is 1 oz and test conditions is under natural convection or zero air flow.

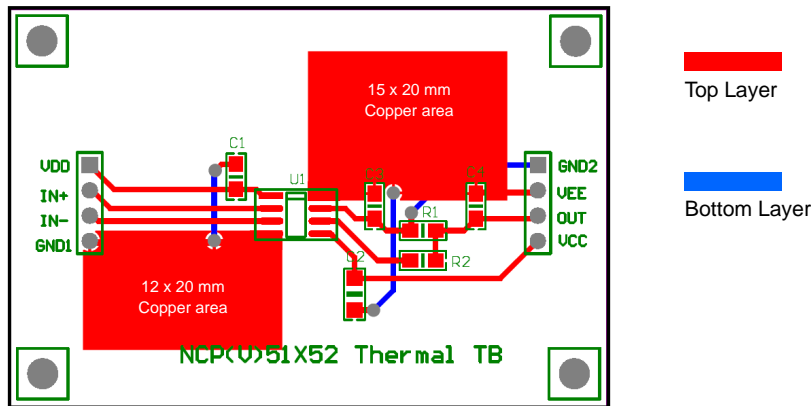

Figure 4. Reference Layout for the Type–A

8. As specified for a reference layout shown in Figure 5. The DUT is mounted on a 60 x 40 x 1.6 mm FR4 substrate with an additional heat spreading copper of 240 mm²/300 mm² (Primary/Secondary). The copper thickness is 1 oz and test conditions is under natural convection or zero air flow.

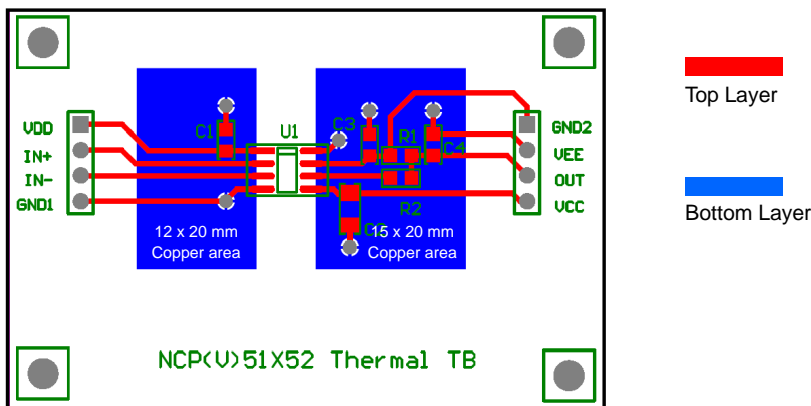

Figure 5. Reference Layout for the Type–B

NCP51152

RECOMMENDED OPERATING CONDITIONS

Symbol	Rating	Min	Max	Unit	
V _{DD}	Power Supply Voltage – Input Side	3.0	20	V	
V _{CC}	Power Supply Voltage – Driver Side (Note 9)	5-V UVLO Version	6.5	30	V
		8-V UVLO Version	9.5	30	V
		12-V UVLO Version	13.5	30	V
		17-V UVLO Version	18.5	30	V
VEE – GND2	Negative Supply Voltage for only Variant B (NCP51152xB)	-15	0	V	
V _{IN}	Logic Input Voltage at Pins IN+, and IN-	0	V _{DD}	V	
T _A	Ambient Temperature	-40	+125	°C	
T _J	Junction Temperature	-40	+125	°C	
CMTI	Common Mode Transient Immunity	200	-	kV/μs	

Functional operation above the stresses listed in the Recommended Operating Ranges is not implied. Extended exposure to stresses beyond the Recommended Operating Ranges limits may affect device reliability.

9. All V_{CC} UVLO threshold voltages of the variant A and B are given with respect to V_{EE} and GND2 pins respectively.

ISOLATION CHARACTERISTICS

Symbol	Parameter	Condition	Value	Unit
V _{ISO, INPUT TO OUTPUT}	Input to Output Isolation Voltage	T _A = 25°C, Relative Humidity < 50%, t = 1.0 minute, I _{I-O} < 30 μA, 50 Hz (Note 10,11,12)	3750	V _{RMS}
R _{ISO}	Isolation Resistance	V _{I-O} = 500 V (Note 10)	10 ¹¹	Ω

10. Device is considered a two-terminal device: pins 1 to 4 are shorted together and pins 5 to 8 are shorted together.

11. 3,750 V_{RMS} for 1-minute duration is equivalent to 4,500 V_{RMS} for 1-second duration for input to output isolation test, and Impulse Test > 10 ms; sample tested for between channel isolation test.

12. The input-output isolation voltage is a dielectric voltage rating per UL1577. It should not be regarded as an input-output continuous voltage rating. For the continuous working voltage rating, refer to equipment-level safety specification or DIN VDE V 0884-11 Safety and Insulation Ratings Table.

NCP51152

ELECTRICAL CHARACTERISTICS ($V_{DD} = 5\text{ V}$, $V_{CC} = 15\text{ V}$, or 20 V ($V_{EE} = 0\text{ V}$ for NCP51151xB) (Note 15) for typical values $T_J = T_A = 25^\circ\text{C}$, for min/max values $T_J = -40^\circ\text{C}$ to $+125^\circ\text{C}$, unless otherwise specified. (Note 15))

Symbol	Parameter	Condition	Min	Typ	Max	Unit
PRIMARY POWER SUPPLY SECTION (VDD)						
I_{QVDD}	V_{DD} Quiescent Current	$V_{IN+} = V_{IN-} = 0\text{ V}$, $V_{DD} = 5\text{ V}$	500	715	1000	μA
		$V_{IN+} = V_{IN-} = 0\text{ V}$, $V_{DD} = 15\text{ V}$	600	870	1100	μA
		$V_{IN+} = V_{IN-} = V_{DD}$, $V_{DD} = 5\text{ V}$	500	720	1000	μA
		$V_{IN+} = V_{IN-} = V_{DD}$, $V_{DD} = 15\text{ V}$	600	870	1100	μA
I_{VDD}	V_{DD} Operating Current	$V_{IN+} = V_{DD}$, $V_{IN-} = 0\text{ V}$, $V_{DD} = 5\text{ V}$	4.5	6.4	8.0	mA
		$V_{IN+} = V_{DD}$, $V_{IN-} = 0\text{ V}$, $V_{DD} = 15\text{ V}$	5.0	6.6	8.4	mA
		$f_{IN+} = 500\text{ kHz}$, $C_{OUT} = 200\text{ pF}$, $V_{DD} = 5\text{ V}$	2.9	3.9	5.0	mA
		$f_{IN+} = 500\text{ kHz}$, $C_{OUT} = 200\text{ pF}$, $V_{DD} = 15\text{ V}$	3.0	4.1	5.2	mA
V_{DDUV+}	V_{DD} Supply Under-Voltage Positive-Going Threshold	$V_{DD} = \text{Sweep}$	2.7	2.8	2.9	V
V_{DDUV-}	V_{DD} Supply Under-Voltage Negative-Going Threshold	$V_{DD} = \text{Sweep}$	2.6	2.7	2.8	V
V_{DDHYS}	V_{DD} Supply Under-Voltage Lockout Hysteresis	$V_{DD} = \text{Sweep}$	–	0.1	–	V
t_{VDDUV}	Debounce Time (Note 16)		–	–	10	μs

SECONDARY POWER SUPPLY SECTION

I_{QVCC}	V_{CC} Quiescent Current	$V_{IN+} = V_{IN-} = 0\text{ V}$ or 5 V , No Load	200	385	700	μA
		$V_{IN+} = 5\text{ V}$, $V_{IN-} = 0\text{ V}$, No Load	200	507	800	μA
I_{VCC}	V_{CC} Operating Current	$f_{IN+} = 500\text{ kHz}$, $C_{OUT} = 200\text{ pF}$, $V_{CC} = 15\text{ V}$	3.0	4.2	5.0	mA
		$f_{IN+} = 500\text{ kHz}$, $C_{OUT} = 200\text{ pF}$, $V_{CC} = 20\text{ V}$	3.7	5.2	6.2	mA

VCC UVLO THRESHOLD (6-V UVLO VERSION)

V_{CCUV+}	V_{CC} Supply Under-Voltage Positive-Going Threshold (Note 13)		5.7	6.0	6.4	V
V_{CCUV-}	V_{CC} Supply Under-Voltage Negative-Going Threshold		5.3	5.7	6.0	V
V_{CCHYS}	Under-Voltage Lockout Hysteresis		–	0.3	–	V
t_{VCCUV}	UVLO Filter Debounce Time (Note 16)		–	–	10	μs

VCC UVLO THRESHOLD (8-V UVLO VERSION)

V_{CCUV+}	V_{CC} Supply Under-Voltage Positive-Going Threshold (Note 13)		8.2	8.7	9.2	V
V_{CCUV-}	V_{CC} Supply Under-Voltage Negative-Going Threshold		7.7	8.2	8.7	V
V_{CCHYS}	Under-Voltage Lockout Hysteresis		–	0.5	–	V
t_{VCCUV}	UVLO Filter Debounce Time (Note 16)		–	–	10	μs

VCC UVLO THRESHOLD (12-V UVLO VERSION)

V_{CCUV+}	V_{CC} Supply Under-Voltage Positive-Going Threshold (Note 13)		11	12	13	V
V_{CCUV-}	V_{CC} Supply Under-Voltage Negative-Going Threshold		10	11	12	V
V_{CCHYS}	Under-Voltage Lockout Hysteresis		–	1.0	–	V
t_{VCCUV}	UVLO Filter Debounce Time (Note 16)		–	–	10	μs

NCP51152

ELECTRICAL CHARACTERISTICS ($V_{DD} = 5\text{ V}$, $V_{CC} = 15\text{ V}$, or 20 V ($V_{EE} = 0\text{ V}$ for NCP51151xB) (Note 15) for typical values $T_J = T_A = 25^\circ\text{C}$, for min/max values $T_J = -40^\circ\text{C}$ to $+125^\circ\text{C}$, unless otherwise specified. (Note 15)) (continued)

Symbol	Parameter	Condition	Min	Typ	Max	Unit
VCC UVLO THRESHOLD (17-V UVLO VERSION)						
V_{CCUV+}	V_{CC} Supply Under-Voltage Positive-Going Threshold (Note 13)		16	17	18	V
V_{CCUV-}	V_{CC} Supply Under-Voltage Negative-Going Threshold		15	16	17	V
V_{CCHYS}	Under-Voltage Lockout Hysteresis		–	1.0	–	V
t_{VCCUV}	UVLO Filter Debounce Time (Note 16)		–	–	10	μs

LOGIC INPUT SECTION (IN+, AND IN-)

V_{INH}	High Level Input Voltage		1.4	1.63	2.0	V
V_{INL}	Low Level Input Voltage		0.8	1.08	1.4	V
V_{INHYS}	Input Logic Hysteresis		–	0.55	–	V
I_{IN+H}	High Level Logic Input Bias Current at IN+	$V_{IN+} = 5\text{ V}$	33	40	52	μA
I_{IN+L}	Low Level Logic Input Bias Current at IN-	$V_{IN+} = \text{GND1}$	–	–	1.0	μA
I_{IN-H}	High Level Logic Input Bias Current at IN+	$V_{IN-} = 5\text{ V}$	-1.0	–	–	μA
I_{IN-L}	Low Level Logic Input Bias Current at IN-	$V_{IN-} = \text{GND1}$	-52	-40	-33	μA
R_{IN}	Logic Input Pull-Up/Down Resistance		95	125	155	k Ω

SHORT CIRCUIT SECTION

$V_{CLP-OUT}$	Clamping Voltage, Sourcing ($V_{OUTH} - V_{CC}$ or $V_{OUT} - V_{CC}$)	$I_{N+} = \text{High}$, $I_{N-} = \text{Low}$, $t_{CLAMP} = 10\ \mu\text{s}$ I_{OUTH} or $I_{OUT} = 500\ \text{mA}$	–	0.7	1.75	V
	Clamping Voltage, Sinking ($V_{EE} - V_{OUTL}$ or $V_{EE} - V_{OUT}$)	$I_{N+} = \text{Low}$, $I_{N-} = \text{High}$, $t_{CLAMP} = 10\ \mu\text{s}$ I_{OUTH} or $I_{OUT} = -500\ \text{mA}$	–	0.24	0.5	V

GATE DRIVE SECTION

I_{OUT+}	Source Peak Current (Note 16)	$V_{IN+} = 5\text{ V}$, $PW \leq 5\ \mu\text{s}$	2.6	4.5	–	A
I_{OUT-}	Sink Peak Current (Note 16)	$V_{IN+} = 0\text{ V}$, $PW \leq 5\ \mu\text{s}$	7.0	9.0	–	A
R_{OH}	Output Resistance at High State	$I_{OUTH} = 100\ \text{mA}$	–	1.4	2.8	Ω
R_{OL}	Output Resistance at Low State	$I_{OUTL} = 100\ \text{mA}$	–	0.5	1.0	Ω
V_{OH}	High Level Output Voltage ($V_{CC} - V_{OUT}$)	$I_{OUTH} = 100\ \text{mA}$	–	140	280	mV
V_{OL}	Low Level Output Voltage ($V_{OUT} - V_{EE}$)	$I_{OUTL} = 100\ \text{mA}$	–	50	100	mV

Product parametric performance is indicated in the Electrical Characteristics for the listed test conditions, unless otherwise noted. Product performance may not be indicated by the Electrical Characteristics if operated under different conditions.

13. All V_{CC} UVLO threshold voltages are given with respect to GND2 pin.

14. Performance guaranteed over the indicated operating temperature range by design and/or characterization tested at $T_J = T_A = 25^\circ\text{C}$.

15. $V_{CC} = 15\text{ V}$ is used for the test condition of 5-V, and 8-V UVLO, $V_{CC} = 20\text{ V}$ is used for 12-V and 17-V UVLO.

16. These parameters verified by bench test only and not tested in production

DYNAMIC ELECTRICAL CHARACTERISTICS

Symbol	Parameter	Condition	Min	Typ	Max	Unit
t_{PDON}	Turn-On Propagation Delay from IN to OUT	$C_{LOAD} = 0\ \text{nF}$	20	36	55	ns
t_{PDOFF}	Turn-Off Propagation Delay from IN to OUT		20	36	55	ns
t_{PWD}	Pulse Width Distortion ($t_{PDON} - t_{PDOFF}$)		-5	–	5	ns
$t_{SK(PP)}$	Propagation Part-to-part Skew (Note 17)		-20	–	20	ns
$t_{VPOR\ to\ OUT}$	Power-up Delay from the V_{POR} to Output (Note 17)	See the Figure 47	–	18	–	μs
t_R	Turn-On Rise Time	$C_{LOAD} = 1.8\ \text{nF}$	–	12	22	ns
t_F	Turn-Off Fall Time	$C_{LOAD} = 1.8\ \text{nF}$	–	8.3	22	ns
t_{PW}	Minimum Input Pulse Width that Change Output State	$C_{LOAD} = 0\ \text{nF}$	–	15	35	ns

Product parametric performance is indicated in the Electrical Characteristics for the listed test conditions, unless otherwise noted. Product performance may not be indicated by the Electrical Characteristics if operated under different conditions.

17. These parameters verified by bench test only and not tested in production

INSULATION CHARACTERISTICS CURVES

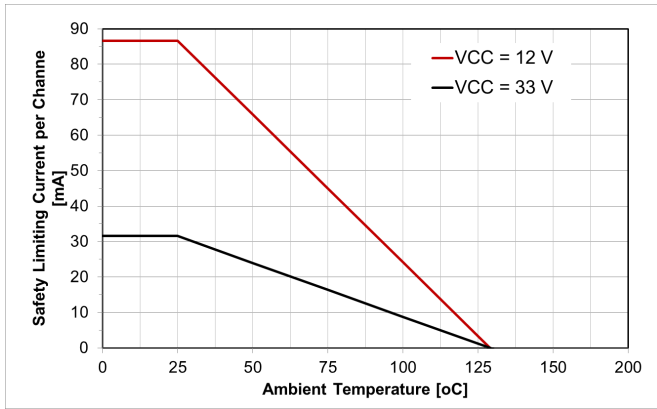

Figure 6. Thermal Derating Curve for Safety-related Limiting Current ($\theta_{JA} = 110^{\circ}\text{C/W}$) (Note 7)

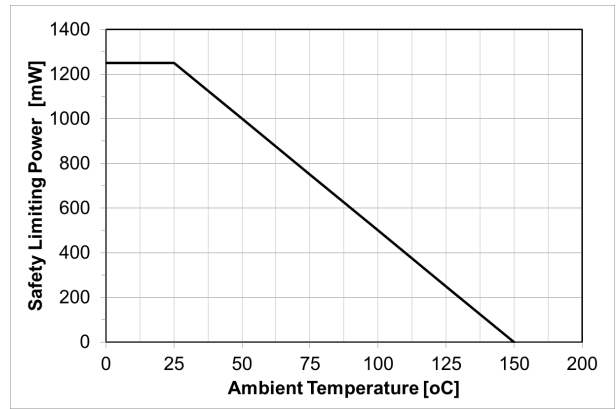

Figure 7. Thermal Derating Curve for Safety-related Limiting Power ($\theta_{JA} = 110^{\circ}\text{C/W}$) (Note 7)

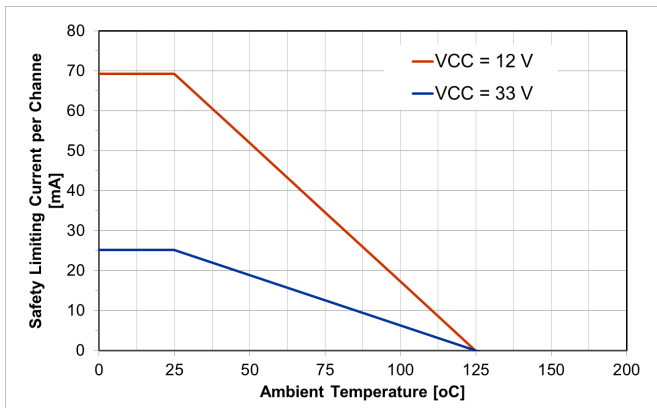

Figure 8. Thermal Derating Curve for Safety-related Limiting Current ($\theta_{JA} = 130^{\circ}\text{C/W}$) (Note 8)

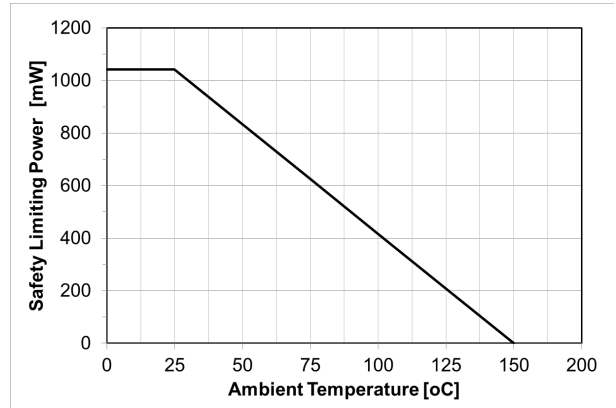

Figure 9. Thermal Derating Curve for Safety-related Limiting Power ($\theta_{JA} = 130^{\circ}\text{C/W}$) (Note 8)

TYPICAL CHARACTERISTICS

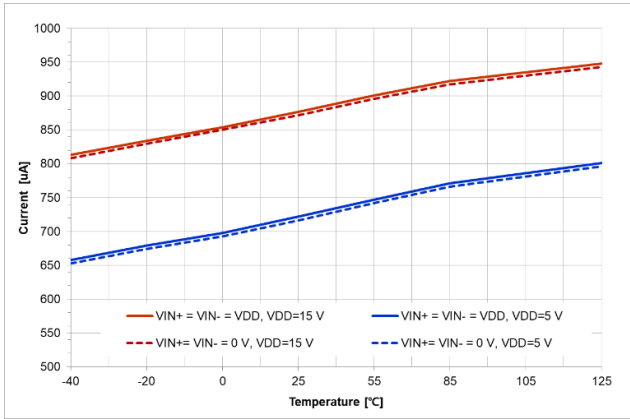

Figure 10. V_{DD} Quiescent Current vs. Temperature

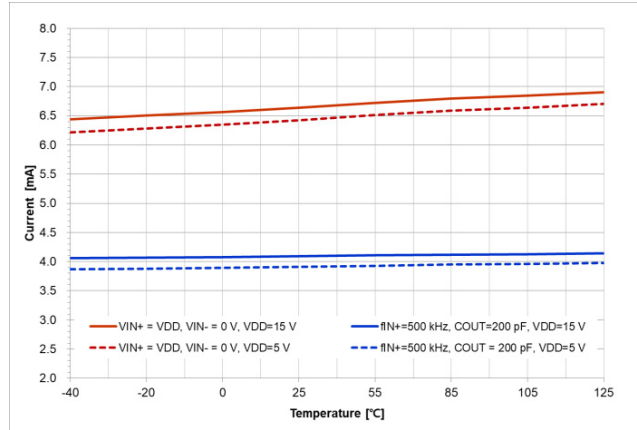

Figure 11. V_{DD} Quiescent Current vs. Temperature

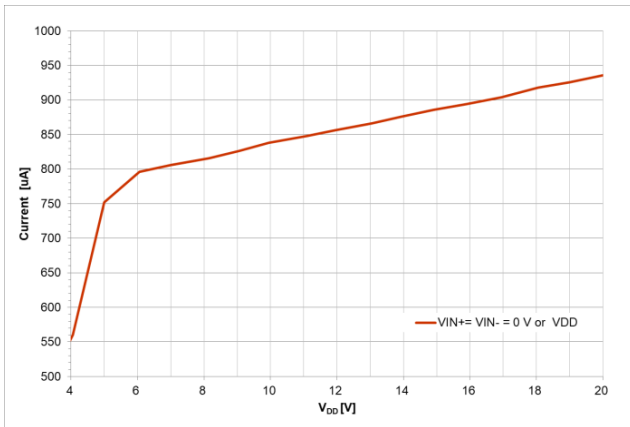

Figure 12. V_{DD} Quiescent Current vs. V_{DD}

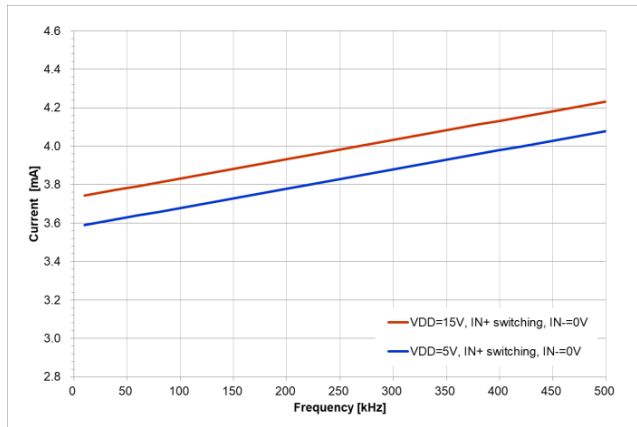

Figure 13. V_{DD} Operating Current vs. Switching Frequency

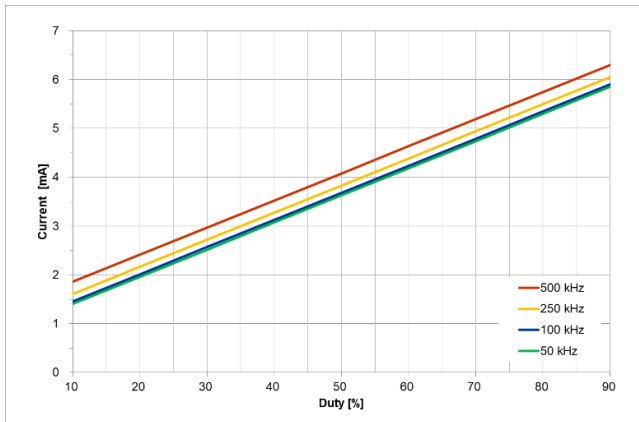

Figure 14. V_{DD} Operating Current vs. Duty ($V_{DD} = 5 V$, $IN+$ Switching with Different Frequency, $IN- = 0 V$)

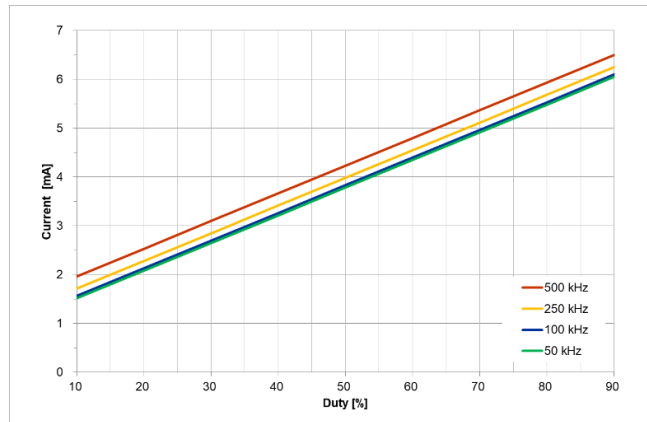

Figure 15. V_{DD} Operating Current vs. Duty ($V_{DD} = 15 V$, $IN+$ Switching with Different Frequency, $IN- = 0 V$)

TYPICAL CHARACTERISTICS (CONTINUED)

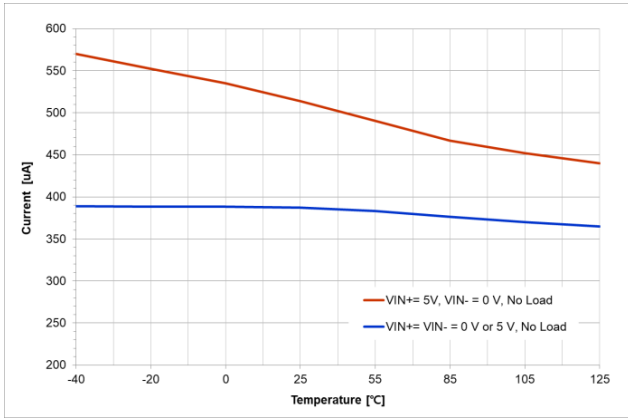

Figure 16. Quiescent V_{CC} Supply Current vs. Temperature

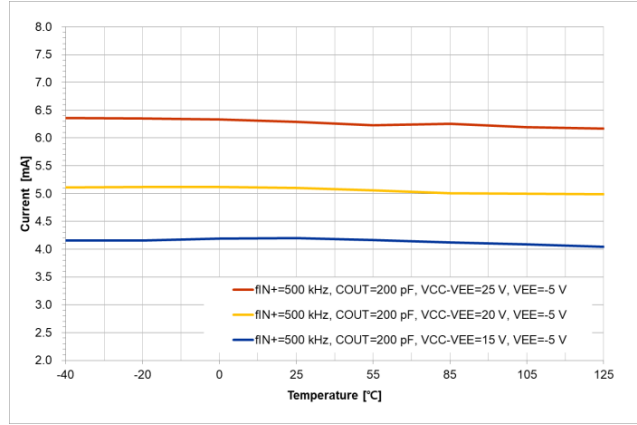

Figure 17. V_{CC} Operating Current vs. Temperature

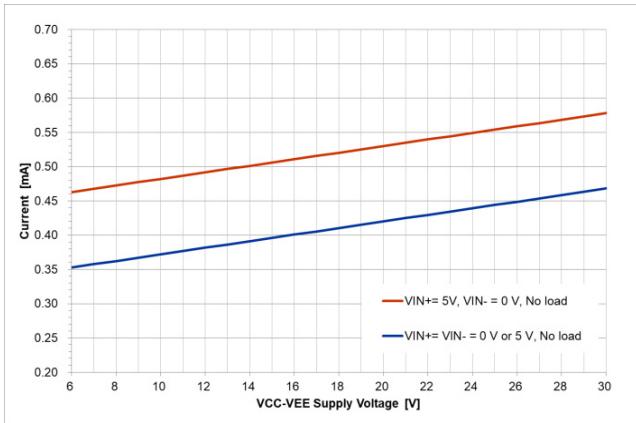

Figure 18. Quiescent V_{CC} Supply Current vs. V_{CC} Supply Voltage

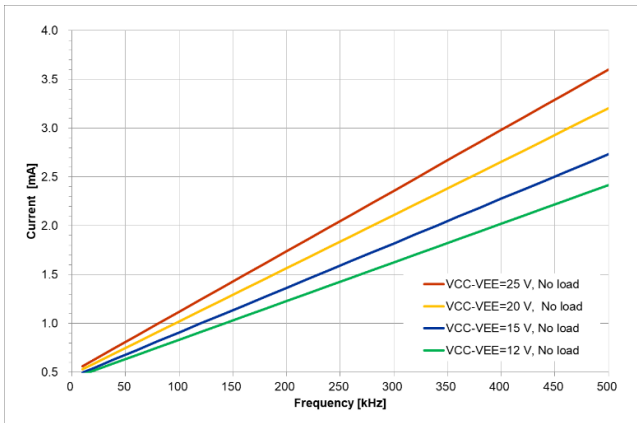

Figure 19. V_{CC} Operating Current vs. Switching Frequency ($V_{CC} - V_{EE} = 12/15/20/25$ V and No Load)

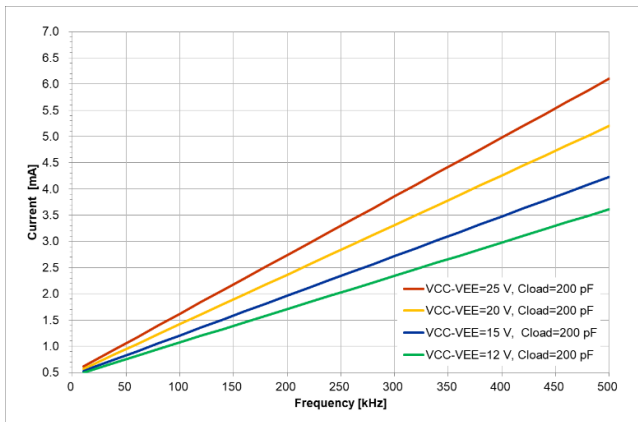

Figure 20. V_{CC} Operating Current vs. Switching Frequency ($V_{CC} - V_{EE} = 12/15/20/25$ V and $C_{LOAD} = 200$ pF)

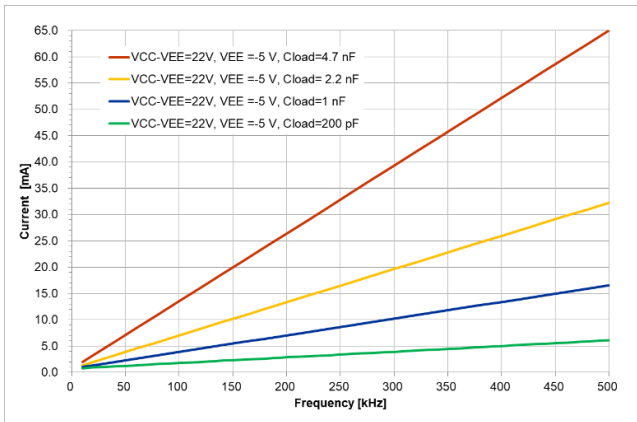

Figure 21. V_{CC} Operating Current vs. Switching Frequency ($V_{CC} - V_{EE} = 20$ V and Different C_{LOAD})

TYPICAL CHARACTERISTICS (CONTINUED)

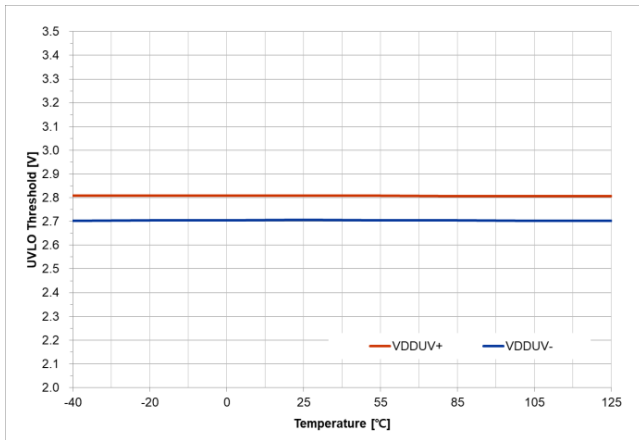

Figure 22. V_{DD} UVLO vs. Temperature

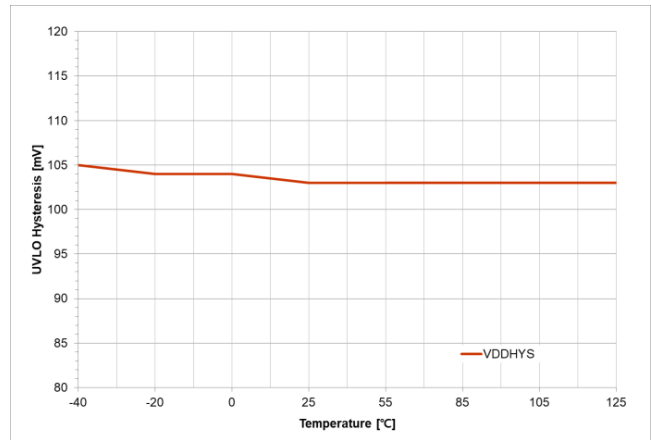

Figure 23. V_{DD} UVLO Hysteresis vs. Temperature

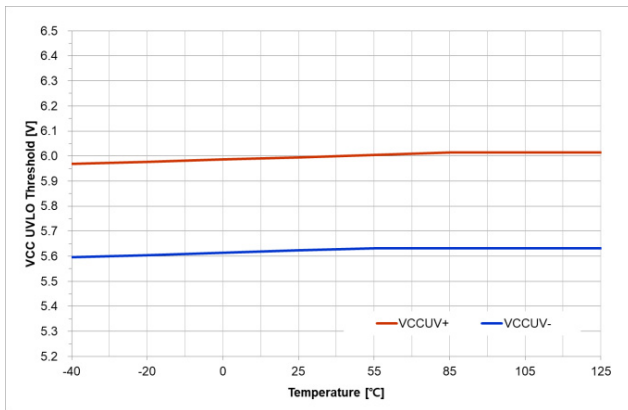

Figure 24. V_{CC} 6-V UVLO Threshold vs. Temperature

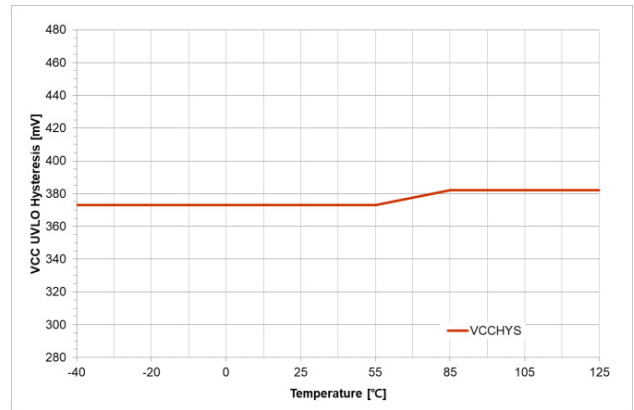

Figure 25. V_{DD} 6-V UVLO Hysteresis vs. Temperature

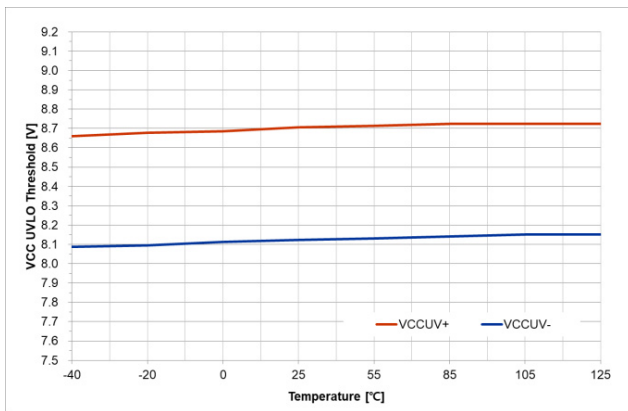

Figure 26. V_{CC} 8-V UVLO Threshold vs. Temperature

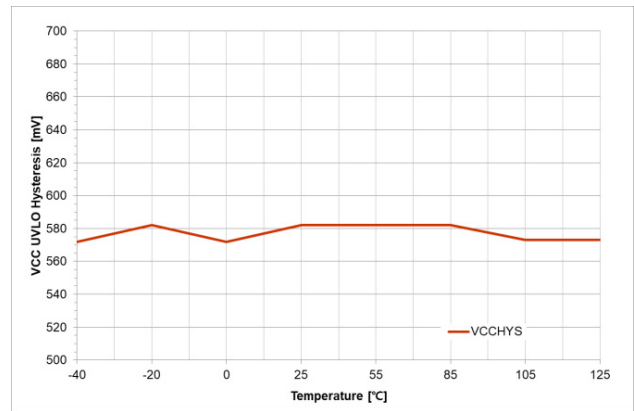

Figure 27. V_{DD} 8-V UVLO Hysteresis vs. Temperature

TYPICAL CHARACTERISTICS (CONTINUED)

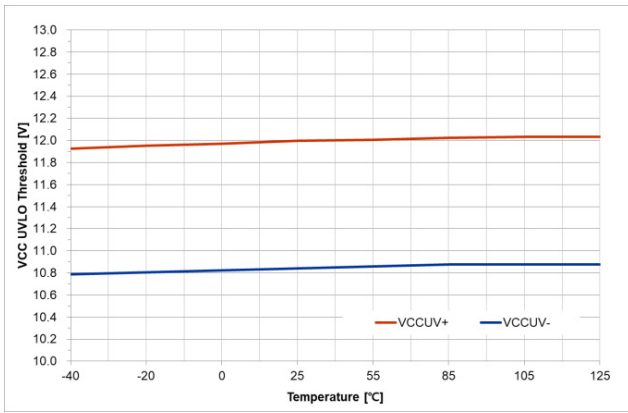

Figure 28. V_{CC} 12-V UVLO Threshold vs. Temperature

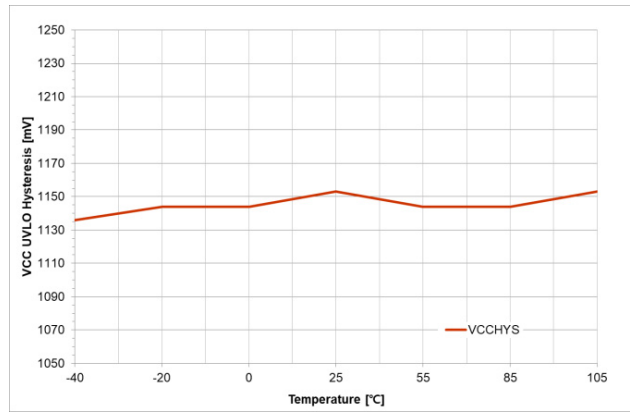

Figure 29. V_{CC} 12-V UVLO Hysteresis vs. Temperature

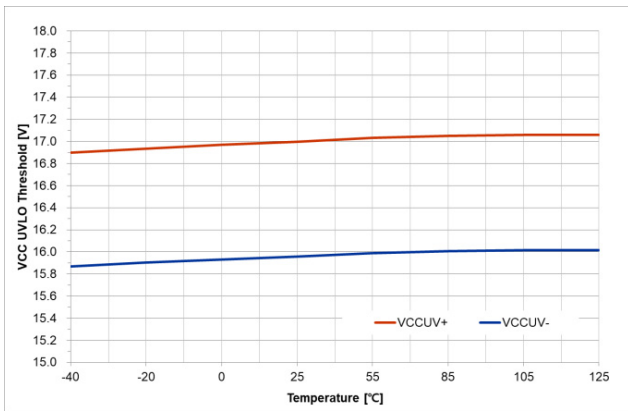

Figure 30. V_{CC} 17-V UVLO Threshold vs. Temperature

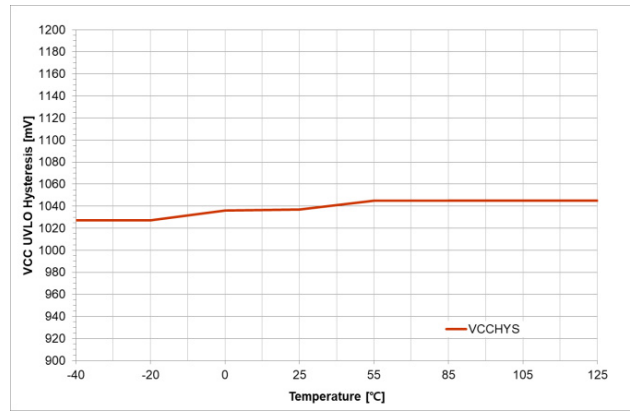

Figure 31. V_{CC} 17-V UVLO Hysteresis vs. Temperature

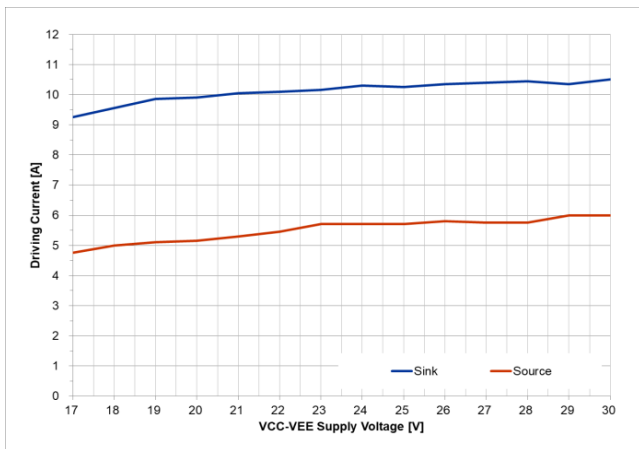

Figure 32. Figure 32. Output Current vs. V_{CC} Supply Voltage

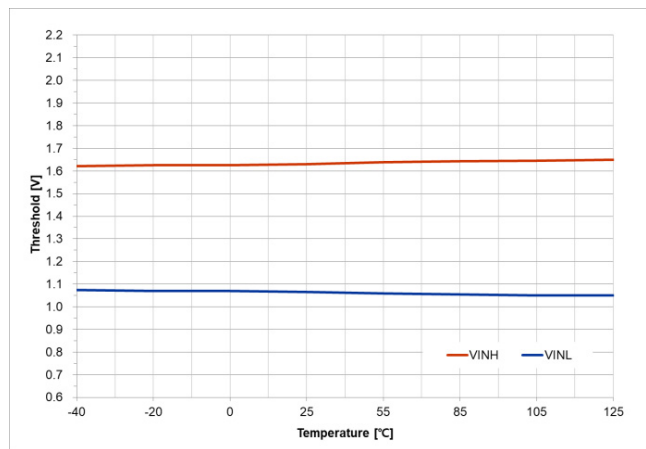

Figure 33. Input Logic Threshold vs. Temperature

TYPICAL CHARACTERISTICS (CONTINUED)

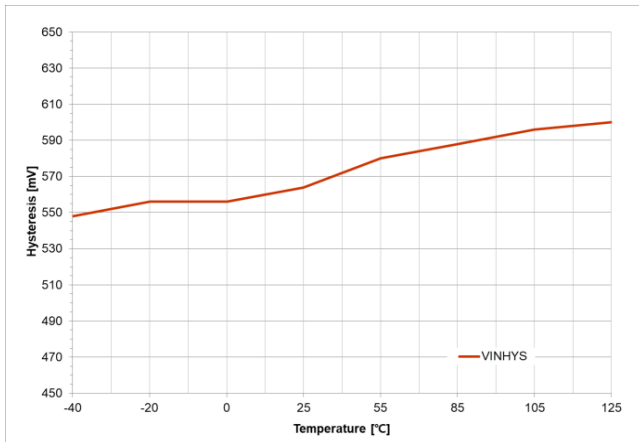

Figure 34. Input Logic Hysteresis vs. Temperature

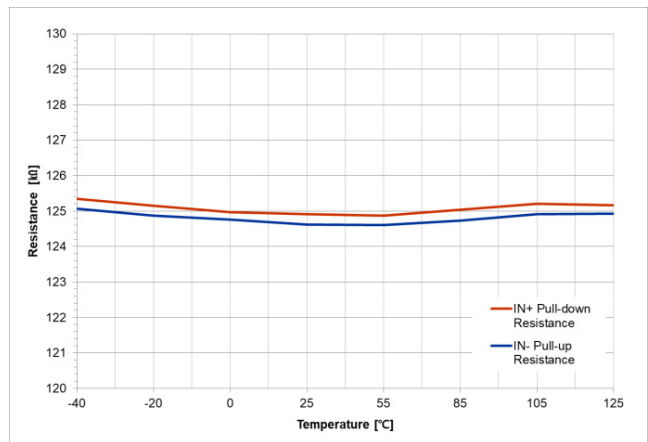

Figure 35. Logic Input Pull-Up/Down Resistance vs. Temperature

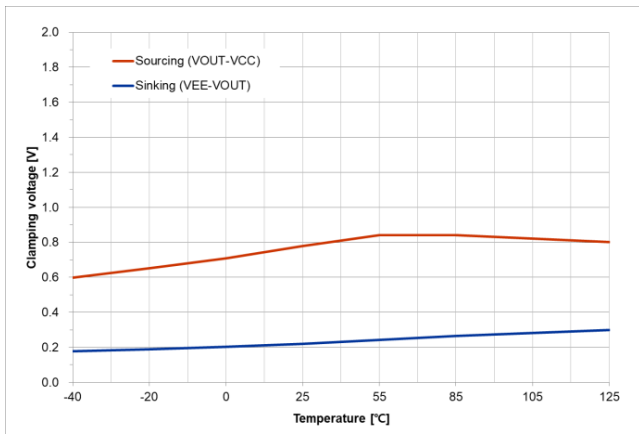

Figure 36. Clamping Voltage vs. Temperature

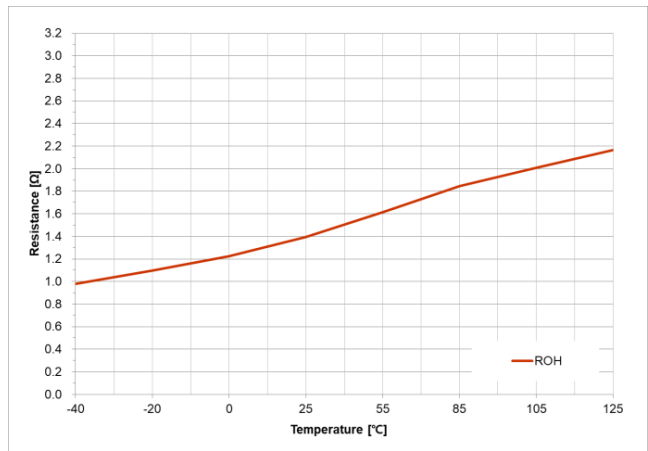

Figure 37. Output Resistance at High State vs. Temperature

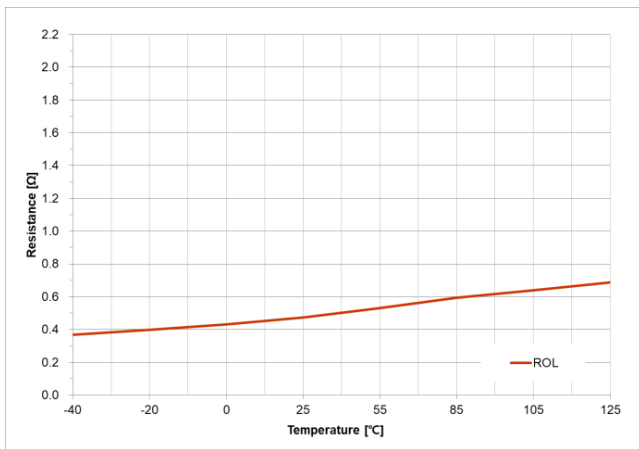

Figure 38. Output Resistance at Low State vs. Temperature

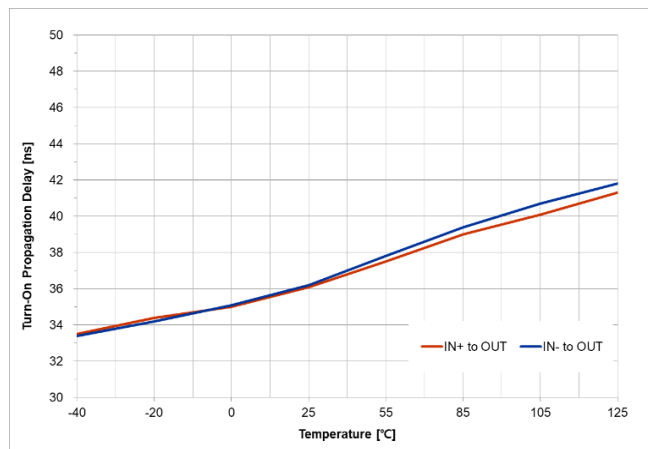

Figure 39. Turn-on Propagation Delay vs. Temperature ($C_{LOAD} = 0 \text{ nF}$)

TYPICAL CHARACTERISTICS (CONTINUED)

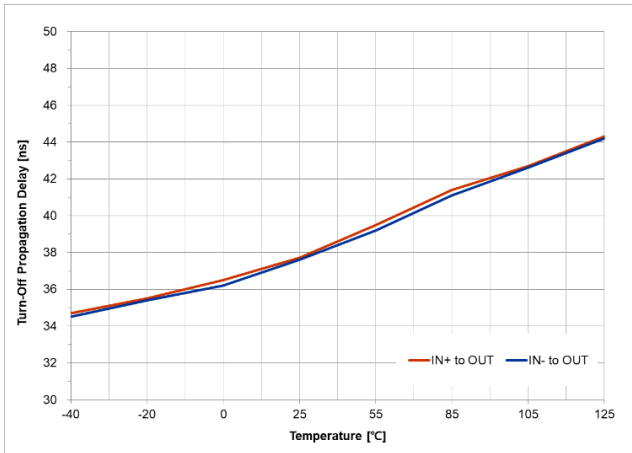

Figure 40. Turn-off Propagation Delay vs. Temperature ($C_{LOAD} = 0 \text{ nF}$)

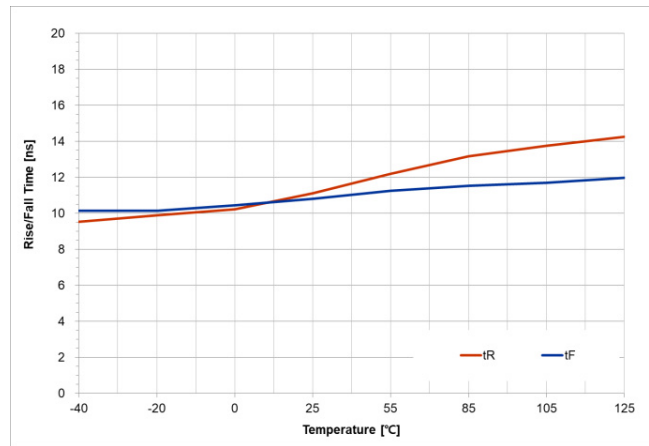

Figure 41. Rise/Fall Time vs. Temperature ($C_{LOAD} = 1.8 \text{ nF}$)

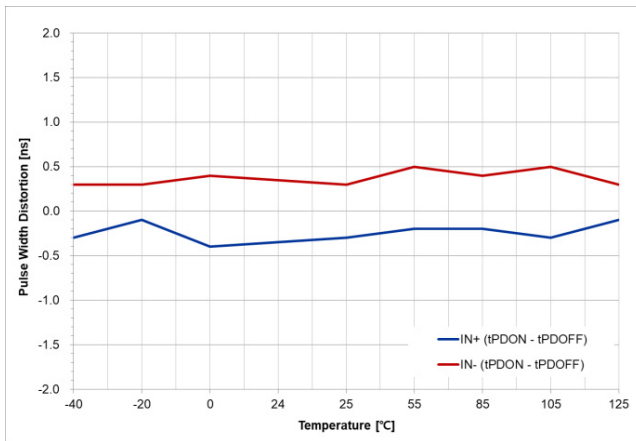

Figure 42. Pulse Width Distortion vs. Temperature ($C_{LOAD} = 0 \text{ nF}$)

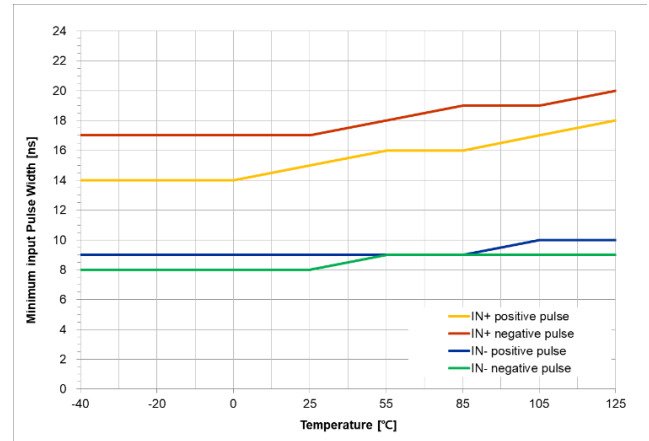

Figure 43. Minimum Input Pulse Width vs. Temperature

PARAMETER MEASUREMENT DEFINITION

Switching Time Definitions

Figure 44 shows the switching time waveforms definitions of the turn-on (t_{PDON}) and turn-off (t_{PDOFF})

propagation delay times among the driver's input signal IN+ and output signal OUT. The typical values of the propagation delay (t_{PDON} , t_{PDOFF}), pulse width distortion (t_{PWD}) and delay matching between channels times are specified in the electrical characteristics table.

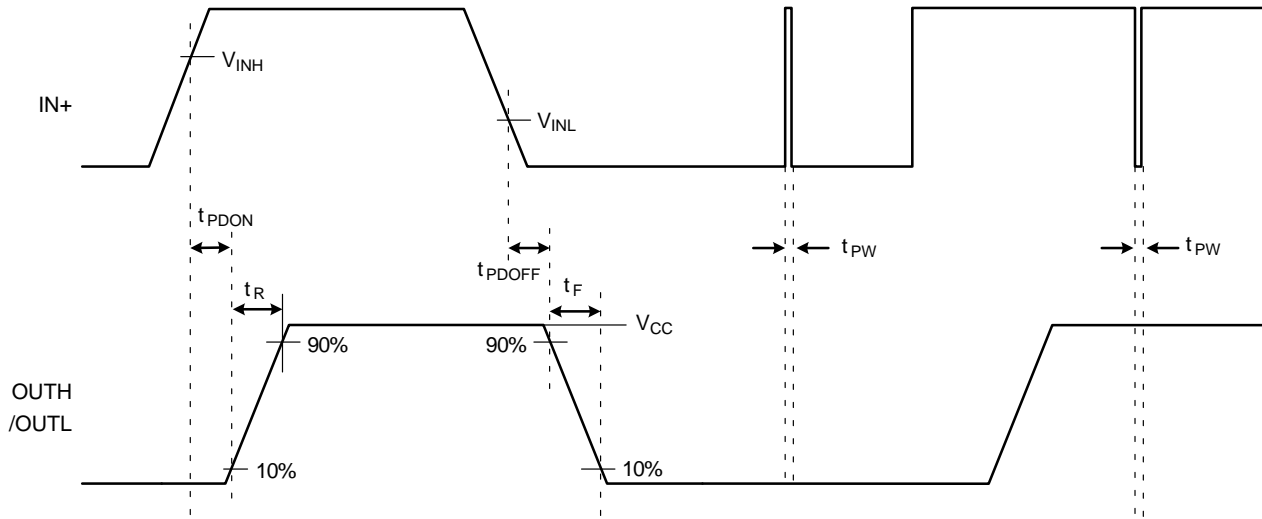

Figure 44. Switching Time Definition

Input to Output Operation Definitions

The NCP51152 provides important protection functions such as independent under-voltage lockout for gate driver. Figure 45 shows an overall input to output timing diagram. Under-Voltage Lockout protection on the primary- and

secondary-sides power supplies events in the *CASE-A, B and C* and the gate driver output (OUT) is immediately turn-off when two input signal (IN+ and IN-) are HIGH at same time in the *CASE-D*.

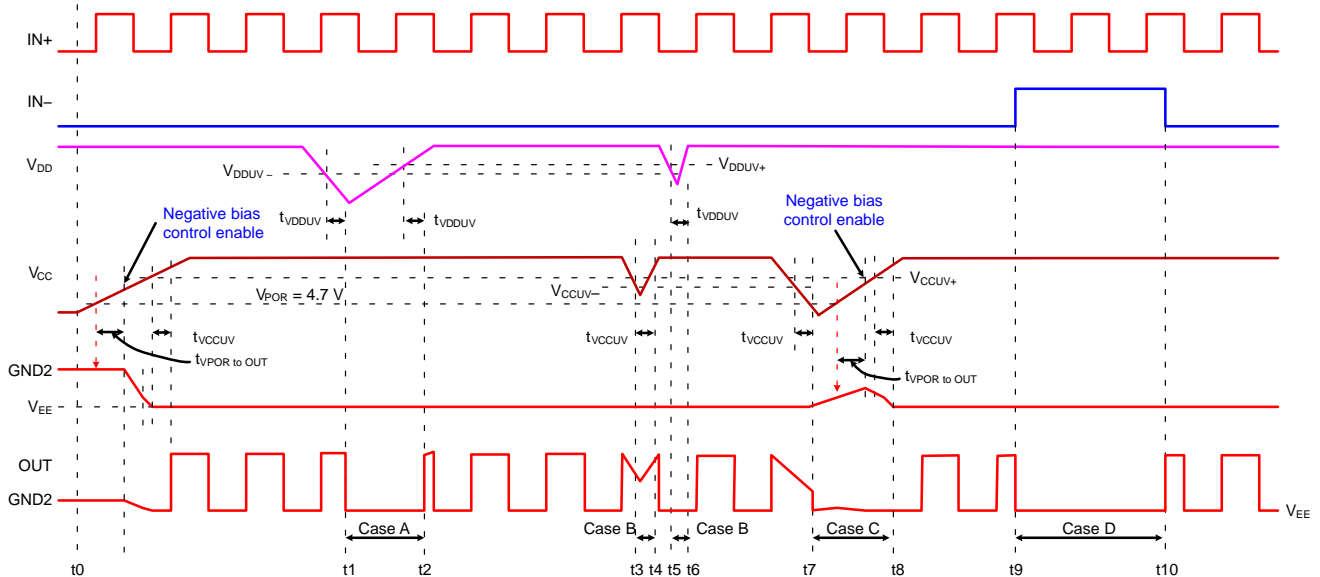

Figure 45. Overall Operating Waveforms Definitions

PROTECTION FUNCTION

The NCP51152 provides the protection features include Under-Voltage Lockout (UVLO) of power supplies on primary-side (V_{DD}), and secondary-side (V_{CC}).

Under-Voltage Lockout Protection V_{DD} and V_{CC}

The NCP51152 provides the Under-Voltage Lockout (UVLO) protection function for V_{DD} in primary-side and gate drive output for V_{CC} in secondary-side as shown in Figure 46. The gate driver is running when the V_{DD} supply voltage is greater than the specified under-voltage lockout threshold voltage (e.g. typically 2.8 V).

In addition, gate output driver has an under-voltage lockout protection (UVLO) function in secondary-side. (e.g. V_{CC}).

The variant A and B need to be greater than specified UVLO threshold level with respect to V_{EE} and GND2 respectively to let the output operate per input signal. The typical V_{CC} UVLO threshold voltage levels for each option respectively as are per Table 1.

Table 1. V_{CC} UVLO OPTION TABLE

Option	V_{CC} UVLO Threshold	V_{CC} UVLO Referenced		Unit
		Variant A	Variant B	
5-V	6.0	V_{EE}	GND2	V
8-V	8.7	V_{EE}	GND2	V
12-V	12	V_{EE}	GND2	V
17-V	17	V_{EE}	GND2	V

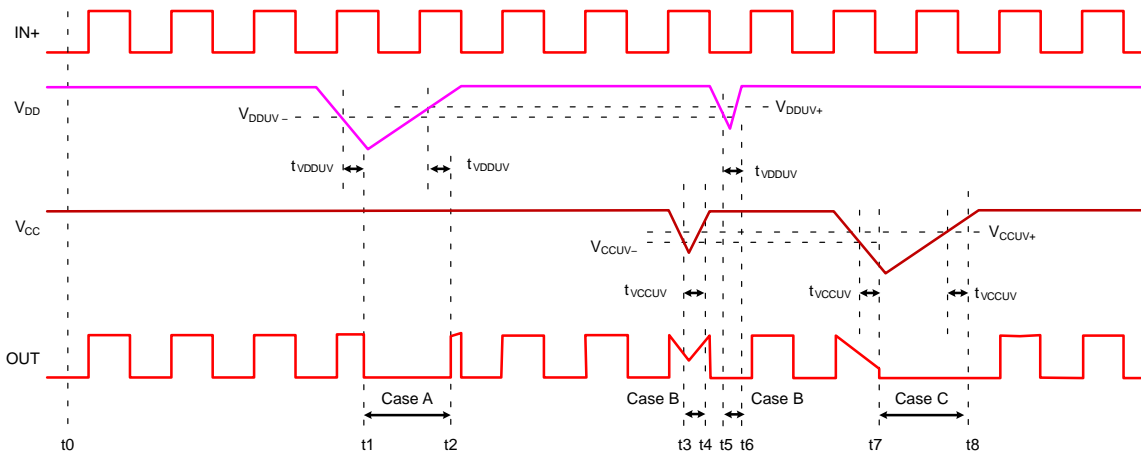

Figure 46. Timing Chart Under-Voltage Lockout Protection

Power-up V_{CC} UVLO Delay to OUTPUT

To provide a variety of Under-Voltage Lockout (UVLO) thresholds NCP51152 has a power-up delay time during initial V_{CC} start-up or after POR event.

Before the gate driver is ready to deliver a proper output state, there is a power-up delay time from the V_{CC} power-on reset (POR) threshold to output and it is defined as $t_{VPOR\ to\ OUT}$. (e.g. typically 18 μs). Figure 47 shows the V_{CC} power-up UVLO delay time diagram.

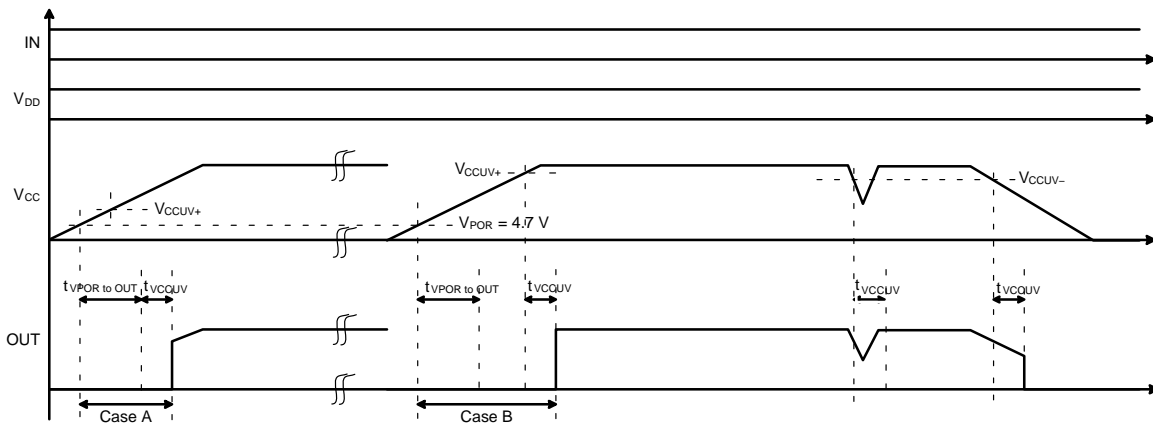

Figure 47. V_{CC} Power-up UVLO Delay Time

FUNCTIONAL MODES TABLE

Table 2 and Table 3 shows the functional modes for the NCP51152 variant A and B assuming V_{DD} and V_{CC} are in the recommended range.

Table 2. FUNCTIONAL MODES FOR THE VARIANT A

Input		Gate Drive Output	
IN+	IN-	OUTH	OUTL
LOW	X (Note 18)	Hi-Z	LOW
X (Note 18)	HIGH	Hi-Z	LOW
HIGH	LOW	HIGH	Hi-Z

Table 3. FUNCTIONAL MODES FOR THE VARIANT B

Input		Gate Drive Output
IN+	IN-	OUT
LOW	X (Note 18)	LOW
X (Note 18)	HIGH	LOW
HIGH	LOW	HIGH

18.X: Don't care

APPLICATION INFORMATION

This section provides application guidelines when using the NCP51152.

Power Supply Recommendations

The NCP51152 variant A and B are designed to support unipolar or bipolar power supply respectively.

The V_{DD} input power supply supports a wide voltage range from 3 V to 20 V and the V_{CC} output supply supports a voltage range from 6.5 V to 30 V. The V_{CC} local bypass capacitor should be placed between the V_{CC} and V_{EE} pins with a value of at least ten times the gate capacitance, and an additional capacitor 100-nF in parallel for device biasing and both capacitors located as close to the device as possible. A low ESR, ceramic surface mount capacitors are recommended. In addition, for the negative bias supply capacitor should be placed between $GND2$ and V_{EE} pins with a value of at least few hundred nanofarads. (variant B). Similarly, the V_{DD} bypass capacitor should also be placed between the V_{DD} and $GND1$ pins for input logic power supply. We recommend using 2 capacitors; at least 100 nF ceramic surface-mount capacitor with few microfarads added in parallel and both capacitors also located as close to the pins of the device as shown in Figure 48.

- In Unipolar power supply the driver is typically supplied with a positive voltage at V_{CC} . For operation with unipolar supply, the V_{CC} supply is connected to 15 V with respect to V_{EE} pin for IGBTs and MOSFET, and 20 V for SiC MOSFETs. (variant A)

- In bipolar power supply the driver is typically supplied of the V_{CC} and V_{EE} output supplies for bipolar operation are 15 V and -8 V with respect to $GND2$ for IGBTs and 20 V and -5 V for SiC MOSFETs. Negative power supply prevents the power device from unintentionally turning on because of current induced from the Miller effect. (variant B)

Input Stage

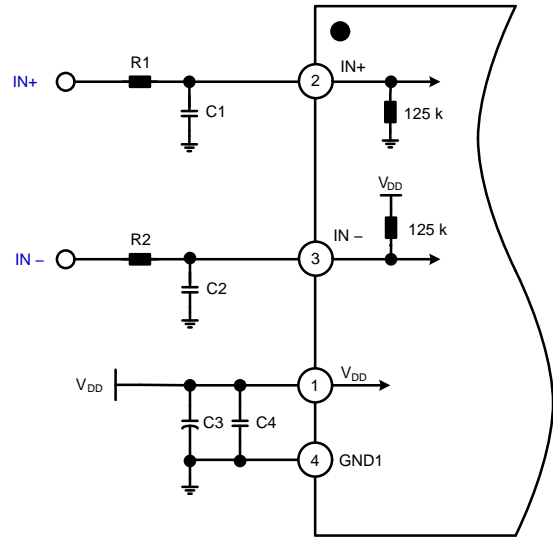

Figure 48. Schematic of Input Stage

The input signal pins (IN+, and IN-) of the NCP51152 are based on the TTL compatible input-threshold logic that is independent of the V_{DD} supply voltage.

The logic level compatible input provides a typically HIGH and LOW threshold of 1.6 V and 1.1 V respectively. The input signal pins impedance is 125 k Ω typically and the IN+ pin is pulled to GND1 pin and IN- pin is pulled to V_{DD} pin as shown in Figure 48. For non-inverting input logic input signal is applied to IN+ while the IN- input can be used as an enable function. If IN- is pulled HIGH, the driver output remains LOW state, regardless of the state of IN+. To enable the driver output, IN- should be tied to GND1 through a few ten k Ω resistor (e.g. 10 k Ω) or can be used as an active LOW enable pull down.

- Non-inverting input IN+ controls the driver output while inverting input IN- is set to LOW
- Inverting input IN- controls the driver output while non-inverting input IN+ is set to HIGH

An RC filter is recommended to be added on the input signal pins to reduce the impact of system noise and ground bounce, the time constant of the RC filter as shown in Figure 48. Such a filter should use an R_{IN} in the range of 0 Ω to 100 Ω and a C_{IN} between 10 pF and 100 pF.

Output Stage

The NCP51152 have different output stages of the variant A and B as shown in Figure 49.

For the variant A is designed to support separate source (OUTH) and sink (OUTL) outputs. This scheme allows a single resistor between each pin and the MOSFET gate to independently control gate ringing as well as fine tuning dV_{DS}/dT turn-on and turn-off transitions present on the MOSFET drain-source voltage.

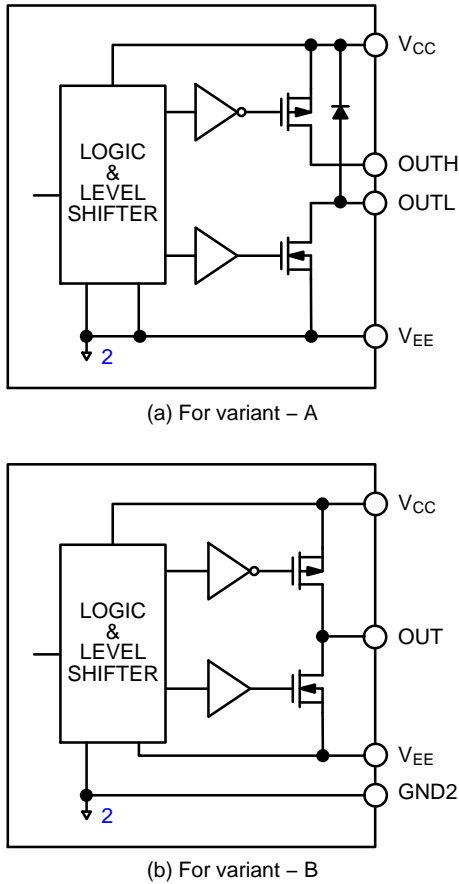

Figure 49. Schematic of Output Stage

The output impedance of the pull up and pull down switches shall be able to provide about +4.5 A and -9 A peak currents typical at 25°C and the minimum sink and source peak currents are -7 A sink and +2.6 A source at 125°C.

Common Mode Transient Immunity Testing

Figure 50 shows a simplified diagram of the Common Mode Transient Immunity (CMTI) testing configuration for each the variant A and B. CMTI is the maximum sustainable common-mode voltage slew rate while maintaining the correct output. CMTI applies to both rising and falling common-mode voltage edges. CMTI is tested with the transient generator connected between GND1 and VEE. ($V_{CM} = 1500$ V).

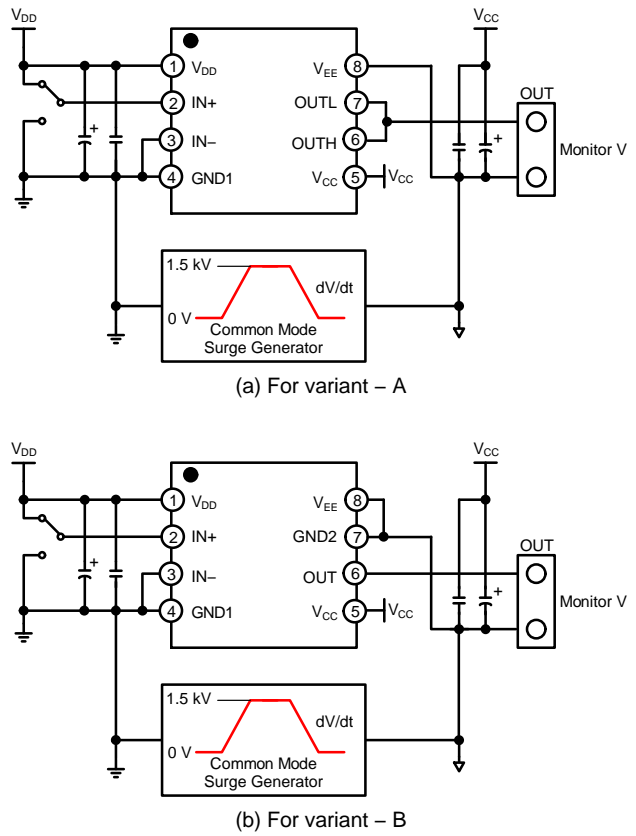

Figure 50. Common Mode Transient Immunity Test Circuit

PCB Layout Guideline

To improve the switching characteristics and efficiency of design, the following should be considered before beginning a PCB layout.

Component Placement

- Keep the input/output traces as short as possible. Minimize influence of the parasitic inductance and capacitance on the layout. (To maintain low signal-path inductance, avoid using via.)
- Placement and routing for supply bypass capacitors for V_{DD} , V_{CC} and V_{EE} , and gate resistors need to be located as close as possible to the gate driver.
- The gate driver should be located switching device as close as possible to decrease the trace inductance and avoid output ringing.

Grounding Consideration

- Have a solid ground plane underneath the high-speed signal layer.

High-Voltage (VISO) Consideration

- To ensure isolation performance between the primary and secondary side, any PCB traces or copper should be not placed under the driver device as shown in Figure 51. A PCB cutout is recommended to avoid contamination that may impair the isolation performance of NCP51152.

NCP51152

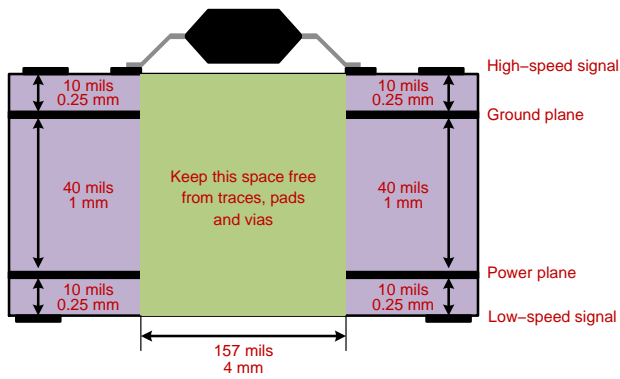

Figure 51. Recommended Layer Stack

Figure 52 shows the 3D layout of the top view of an evaluation board. The component's location of the PCB

cutout between primary and secondary sides ensures isolation performance.

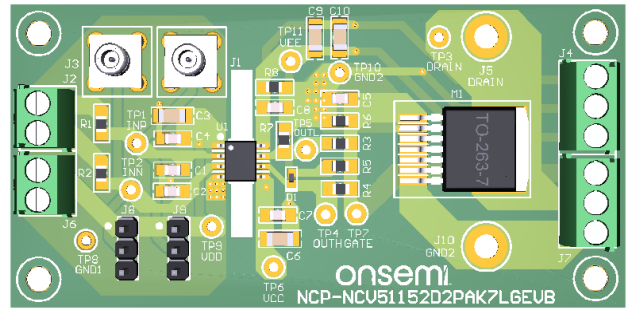
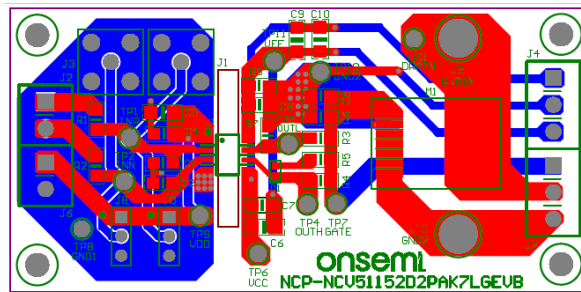
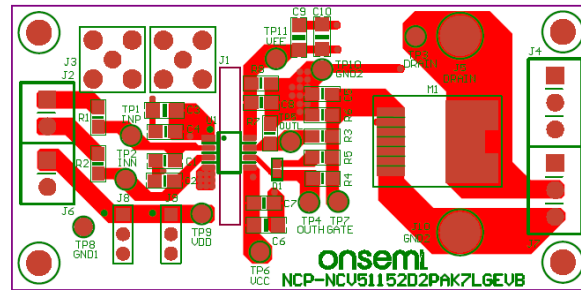

Figure 52. 3-D PCB View

Figure 53 shows the top and bottom layer traces and copper of printed circuit board layout.



(A) Top & Bottom View



(B) Top View

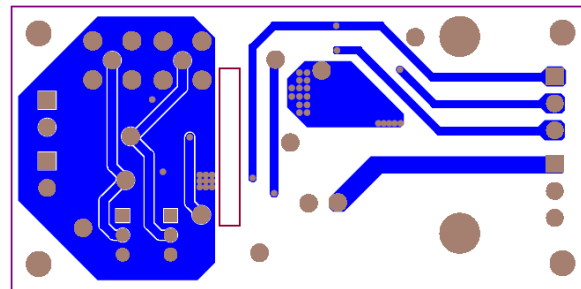

(C) Bottom View

Figure 53. Printed Circuit Board

NCP51152

ORDERING INFORMATION

Device	Description	Package	UVLO	OUTPUT/UVLO/NEG	Shipping [†]
NCP51152AADR2G*	High current single isolated MOS driver	SOIC-8 NB (Pb-Free)	6 V	Split OUTPUT	2500 / Tape & Reel
NCP51152BADR2G		SOIC-8 NB (Pb-Free)	8 V		2500 / Tape & Reel
NCP51152CADR2G		SOIC-8 NB (Pb-Free)	12 V		2500 / Tape & Reel
NCP51152DADR2G*		SOIC-8 NB (Pb-Free)	17 V		2500 / Tape & Reel
NCP51152ABDR2G*	High current single isolated MOS driver with true VCC UVLO	SOIC-8 NB (Pb-Free)	6 V	TRUE VCC UVLO	2500 / Tape & Reel
NCP51152BBDR2G*		SOIC-8 NB (Pb-Free)	8 V		2500 / Tape & Reel
NCP51152CBDR2G*		SOIC-8 NB (Pb-Free)	12 V		2500 / Tape & Reel
NCP51152DBDR2G*		SOIC-8 NB (Pb-Free)	17 V		2500 / Tape & Reel

†For information on tape and reel specifications, including part orientation and tape sizes, please refer to our Tape and Reel Packaging Specifications Brochure, BRD8011/D.

*Option on demand

MECHANICAL CASE OUTLINE PACKAGE DIMENSIONS



SCALE 1:1

SOIC-8 NB
CASE 751-07
ISSUE AK

DATE 16 FEB 2011



- NOTES:
1. DIMENSIONING AND TOLERANCING PER ANSI Y14.5M, 1982.
 2. CONTROLLING DIMENSION: MILLIMETER.
 3. DIMENSION A AND B DO NOT INCLUDE MOLD PROTRUSION.
 4. MAXIMUM MOLD PROTRUSION 0.15 (0.006) PER SIDE.
 5. DIMENSION D DOES NOT INCLUDE DAMBAR PROTRUSION. ALLOWABLE DAMBAR PROTRUSION SHALL BE 0.127 (0.005) TOTAL IN EXCESS OF THE D DIMENSION AT MAXIMUM MATERIAL CONDITION.
 6. 751-01 THRU 751-06 ARE OBSOLETE. NEW STANDARD IS 751-07.

DIM	MILLIMETERS		INCHES	
	MIN	MAX	MIN	MAX
A	4.80	5.00	0.189	0.197
B	3.80	4.00	0.150	0.157
C	1.35	1.75	0.053	0.069
D	0.33	0.51	0.013	0.020
G	1.27 BSC		0.050 BSC	
H	0.10	0.25	0.004	0.010
J	0.19	0.25	0.007	0.010
K	0.40	1.27	0.016	0.050
M	0°	8°	0°	8°
N	0.25	0.50	0.010	0.020
S	5.80	6.20	0.228	0.244

SOLDERING FOOTPRINT*



*For additional information on our Pb-Free strategy and soldering details, please download the ON Semiconductor Soldering and Mounting Techniques Reference Manual, SOLDERRM/D.

GENERIC MARKING DIAGRAM*



XXXXXX = Specific Device Code
A = Assembly Location
L = Wafer Lot
Y = Year
W = Work Week
■ = Pb-Free Package

XXXXXX = Specific Device Code
A = Assembly Location
Y = Year
WW = Work Week
■ = Pb-Free Package

*This information is generic. Please refer to device data sheet for actual part marking. Pb-Free indicator, "G" or microdot "▪", may or may not be present. Some products may not follow the Generic Marking.

STYLES ON PAGE 2

DOCUMENT NUMBER:	98ASB42564B	Electronic versions are uncontrolled except when accessed directly from the Document Repository. Printed versions are uncontrolled except when stamped "CONTROLLED COPY" in red.
DESCRIPTION:	SOIC-8 NB	PAGE 1 OF 2

onsemi and ONsemi are trademarks of Semiconductor Components Industries, LLC dba onsemi or its subsidiaries in the United States and/or other countries. onsemi reserves the right to make changes without further notice to any products herein. onsemi makes no warranty, representation or guarantee regarding the suitability of its products for any particular purpose, nor does onsemi assume any liability arising out of the application or use of any product or circuit, and specifically disclaims any and all liability, including without limitation special, consequential or incidental damages. onsemi does not convey any license under its patent rights nor the rights of others.

SOIC-8 NB
CASE 751-07
ISSUE AK

DATE 16 FEB 2011

- | | | | |
|---|--|--|--|
| <p>STYLE 1:
 PIN 1. EMITTER
 2. COLLECTOR
 3. COLLECTOR
 4. EMITTER
 5. EMITTER
 6. BASE
 7. BASE
 8. EMITTER</p> | <p>STYLE 2:
 PIN 1. COLLECTOR, DIE, #1
 2. COLLECTOR, #1
 3. COLLECTOR, #2
 4. COLLECTOR, #2
 5. BASE, #2
 6. EMITTER, #2
 7. BASE, #1
 8. EMITTER, #1</p> | <p>STYLE 3:
 PIN 1. DRAIN, DIE #1
 2. DRAIN, #1
 3. DRAIN, #2
 4. DRAIN, #2
 5. GATE, #2
 6. SOURCE, #2
 7. GATE, #1
 8. SOURCE, #1</p> | <p>STYLE 4:
 PIN 1. ANODE
 2. ANODE
 3. ANODE
 4. ANODE
 5. ANODE
 6. ANODE
 7. ANODE
 8. COMMON CATHODE</p> |
| <p>STYLE 5:
 PIN 1. DRAIN
 2. DRAIN
 3. DRAIN
 4. DRAIN
 5. GATE
 6. GATE
 7. SOURCE
 8. SOURCE</p> | <p>STYLE 6:
 PIN 1. SOURCE
 2. DRAIN
 3. DRAIN
 4. SOURCE
 5. SOURCE
 6. GATE
 7. GATE
 8. SOURCE</p> | <p>STYLE 7:
 PIN 1. INPUT
 2. EXTERNAL BYPASS
 3. THIRD STAGE SOURCE
 4. GROUND
 5. DRAIN
 6. GATE 3
 7. SECOND STAGE Vd
 8. FIRST STAGE Vd</p> | <p>STYLE 8:
 PIN 1. COLLECTOR, DIE #1
 2. BASE, #1
 3. BASE, #2
 4. COLLECTOR, #2
 5. COLLECTOR, #2
 6. EMITTER, #2
 7. EMITTER, #1
 8. COLLECTOR, #1</p> |
| <p>STYLE 9:
 PIN 1. EMITTER, COMMON
 2. COLLECTOR, DIE #1
 3. COLLECTOR, DIE #2
 4. EMITTER, COMMON
 5. EMITTER, COMMON
 6. BASE, DIE #2
 7. BASE, DIE #1
 8. EMITTER, COMMON</p> | <p>STYLE 10:
 PIN 1. GROUND
 2. BIAS 1
 3. OUTPUT
 4. GROUND
 5. GROUND
 6. BIAS 2
 7. INPUT
 8. GROUND</p> | <p>STYLE 11:
 PIN 1. SOURCE 1
 2. GATE 1
 3. SOURCE 2
 4. GATE 2
 5. DRAIN 2
 6. DRAIN 2
 7. DRAIN 1
 8. DRAIN 1</p> | <p>STYLE 12:
 PIN 1. SOURCE
 2. SOURCE
 3. SOURCE
 4. GATE
 5. DRAIN
 6. DRAIN
 7. DRAIN
 8. DRAIN</p> |
| <p>STYLE 13:
 PIN 1. N.C.
 2. SOURCE
 3. SOURCE
 4. GATE
 5. DRAIN
 6. DRAIN
 7. DRAIN
 8. DRAIN</p> | <p>STYLE 14:
 PIN 1. N-SOURCE
 2. N-GATE
 3. P-SOURCE
 4. P-GATE
 5. P-DRAIN
 6. P-DRAIN
 7. N-DRAIN
 8. N-DRAIN</p> | <p>STYLE 15:
 PIN 1. ANODE 1
 2. ANODE 1
 3. ANODE 1
 4. ANODE 1
 5. CATHODE, COMMON
 6. CATHODE, COMMON
 7. CATHODE, COMMON
 8. CATHODE, COMMON</p> | <p>STYLE 16:
 PIN 1. EMITTER, DIE #1
 2. BASE, DIE #1
 3. EMITTER, DIE #2
 4. BASE, DIE #2
 5. COLLECTOR, DIE #2
 6. COLLECTOR, DIE #2
 7. COLLECTOR, DIE #1
 8. COLLECTOR, DIE #1</p> |
| <p>STYLE 17:
 PIN 1. VCC
 2. V2OUT
 3. V1OUT
 4. TXE
 5. RXE
 6. VEE
 7. GND
 8. ACC</p> | <p>STYLE 18:
 PIN 1. ANODE
 2. ANODE
 3. SOURCE
 4. GATE
 5. DRAIN
 6. DRAIN
 7. CATHODE
 8. CATHODE</p> | <p>STYLE 19:
 PIN 1. SOURCE 1
 2. GATE 1
 3. SOURCE 2
 4. GATE 2
 5. DRAIN 2
 6. MIRROR 2
 7. DRAIN 1
 8. MIRROR 1</p> | <p>STYLE 20:
 PIN 1. SOURCE (N)
 2. GATE (N)
 3. SOURCE (P)
 4. GATE (P)
 5. DRAIN
 6. DRAIN
 7. DRAIN
 8. DRAIN</p> |
| <p>STYLE 21:
 PIN 1. CATHODE 1
 2. CATHODE 2
 3. CATHODE 3
 4. CATHODE 4
 5. CATHODE 5
 6. COMMON ANODE
 7. COMMON ANODE
 8. CATHODE 6</p> | <p>STYLE 22:
 PIN 1. I/O LINE 1
 2. COMMON CATHODE/VCC
 3. COMMON CATHODE/VCC
 4. I/O LINE 3
 5. COMMON ANODE/GND
 6. I/O LINE 4
 7. I/O LINE 5
 8. COMMON ANODE/GND</p> | <p>STYLE 23:
 PIN 1. LINE 1 IN
 2. COMMON ANODE/GND
 3. COMMON ANODE/GND
 4. LINE 2 IN
 5. LINE 2 OUT
 6. COMMON ANODE/GND
 7. COMMON ANODE/GND
 8. LINE 1 OUT</p> | <p>STYLE 24:
 PIN 1. BASE
 2. EMITTER
 3. COLLECTOR/ANODE
 4. COLLECTOR/ANODE
 5. CATHODE
 6. CATHODE
 7. COLLECTOR/ANODE
 8. COLLECTOR/ANODE</p> |
| <p>STYLE 25:
 PIN 1. VIN
 2. N/C
 3. REXT
 4. GND
 5. IOUT
 6. IOUT
 7. IOUT
 8. IOUT</p> | <p>STYLE 26:
 PIN 1. GND
 2. dv/dt
 3. ENABLE
 4. ILIMIT
 5. SOURCE
 6. SOURCE
 7. SOURCE
 8. VCC</p> | <p>STYLE 27:
 PIN 1. ILIMIT
 2. OVLO
 3. UVLO
 4. INPUT+
 5. SOURCE
 6. SOURCE
 7. SOURCE
 8. DRAIN</p> | <p>STYLE 28:
 PIN 1. SW_TO_GND
 2. DASIC_OFF
 3. DASIC_SW_DET
 4. GND
 5. V_MON
 6. VBULK
 7. VBULK
 8. VIN</p> |
| <p>STYLE 29:
 PIN 1. BASE, DIE #1
 2. EMITTER, #1
 3. BASE, #2
 4. EMITTER, #2
 5. COLLECTOR, #2
 6. COLLECTOR, #2
 7. COLLECTOR, #1
 8. COLLECTOR, #1</p> | <p>STYLE 30:
 PIN 1. DRAIN 1
 2. DRAIN 1
 3. GATE 2
 4. SOURCE 2
 5. SOURCE 1/DRAIN 2
 6. SOURCE 1/DRAIN 2
 7. SOURCE 1/DRAIN 2
 8. GATE 1</p> | | |

DOCUMENT NUMBER:	98ASB42564B	Electronic versions are uncontrolled except when accessed directly from the Document Repository. Printed versions are uncontrolled except when stamped "CONTROLLED COPY" in red.
DESCRIPTION:	SOIC-8 NB	PAGE 2 OF 2

onsemi and **ONSEMI** are trademarks of Semiconductor Components Industries, LLC dba **onsemi** or its subsidiaries in the United States and/or other countries. **onsemi** reserves the right to make changes without further notice to any products herein. **onsemi** makes no warranty, representation or guarantee regarding the suitability of its products for any particular purpose, nor does **onsemi** assume any liability arising out of the application or use of any product or circuit, and specifically disclaims any and all liability, including without limitation special, consequential or incidental damages. **onsemi** does not convey any license under its patent rights nor the rights of others.

onsemi, **Onsemi**, and other names, marks, and brands are registered and/or common law trademarks of Semiconductor Components Industries, LLC dba "**onsemi**" or its affiliates and/or subsidiaries in the United States and/or other countries. **onsemi** owns the rights to a number of patents, trademarks, copyrights, trade secrets, and other intellectual property. A listing of **onsemi**'s product/patent coverage may be accessed at www.onsemi.com/site/pdf/Patent-Marking.pdf. **onsemi** reserves the right to make changes at any time to any products or information herein, without notice. The information herein is provided "as-is" and **onsemi** makes no warranty, representation or guarantee regarding the accuracy of the information, product features, availability, functionality, or suitability of its products for any particular purpose, nor does **onsemi** assume any liability arising out of the application or use of any product or circuit, and specifically disclaims any and all liability, including without limitation special, consequential or incidental damages. Buyer is responsible for its products and applications using **onsemi** products, including compliance with all laws, regulations and safety requirements or standards, regardless of any support or applications information provided by **onsemi**. "Typical" parameters which may be provided in **onsemi** data sheets and/or specifications can and do vary in different applications and actual performance may vary over time. All operating parameters, including "Typicals" must be validated for each customer application by customer's technical experts. **onsemi** does not convey any license under any of its intellectual property rights nor the rights of others. **onsemi** products are not designed, intended, or authorized for use as a critical component in life support systems or any FDA Class 3 medical devices or medical devices with a same or similar classification in a foreign jurisdiction or any devices intended for implantation in the human body. Should Buyer purchase or use **onsemi** products for any such unintended or unauthorized application, Buyer shall indemnify and hold **onsemi** and its officers, employees, subsidiaries, affiliates, and distributors harmless against all claims, costs, damages, and expenses, and reasonable attorney fees arising out of, directly or indirectly, any claim of personal injury or death associated with such unintended or unauthorized use, even if such claim alleges that **onsemi** was negligent regarding the design or manufacture of the part. **onsemi** is an Equal Opportunity/Affirmative Action Employer. This literature is subject to all applicable copyright laws and is not for resale in any manner.

ADDITIONAL INFORMATION

TECHNICAL PUBLICATIONS:

Technical Library: www.onsemi.com/design/resources/technical-documentation
onsemi Website: www.onsemi.com

ONLINE SUPPORT: www.onsemi.com/support

For additional information, please contact your local Sales Representative at www.onsemi.com/support/sales