

# Interleaved, 2-Phase Power Factor Controller

## NCP1631

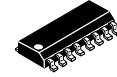

SOIC-16  
 D SUFFIX  
 CASE 751B

The NCP1631 integrates a dual MOSFET driver for interleaved PFC applications. Interleaving consists of paralleling two small stages in lieu of a bigger one, more difficult to design. This approach has several merits like the ease of implementation, the use of smaller components or a better distribution of the heating.

Also, Interleaving extends the power range of Critical Conduction Mode that is an efficient and cost-effective technique (no need for low  $t_{rr}$  diodes). In addition, the NCP1631 drivers are 180° phase shift for a significantly reduced current ripple.

Housed in a SOIC16 package, the circuit incorporates all the features necessary for building robust and compact interleaved PFC stages, with a minimum of external components.

### General Features

- Near-Unity Power Factor
- Substantial 180° Phase Shift in All Conditions Including Transient Phases
- Frequency Clamped Critical Conduction Mode (**FCCrM**) i.e., Fixed Frequency, Discontinuous Conduction Mode Operation with Critical Conduction Achievable in Most Stressful Conditions
- FCCrM Operation Optimizes the PFC Stage Efficiency Over the Load Range
- Out-of-phase Control for Low EMI and a Reduced rms Current in the Bulk Capacitor
- Frequency Fold-back at Low Power to Further Improve the Light Load Efficiency
- Accurate Zero Current Detection by Auxiliary Winding for Valley Turn On
- Fast Line / Load Transient Compensation
- High Drive Capability: -500 mA / +800 mA
- Signal to Indicate that the PFC is Ready for Operation (“pfcOK” Pin)
- $V_{CC}$  Range: from 10 V to 20 V

### Safety Features

- Output Over and Under Voltage Protection
- Brown-Out Detection with a 50-ms Delay to Help Meet Hold-up Time Specifications
- Soft-Start for Smooth Start-up Operation
- Programmable Adjustment of the Maximum Power
- Over Current Limitation
- Detection of Inrush Currents

### Typical Applications

- Computer Power Supplies
- LCD / Plasma Flat Panels
- All Off Line Appliances Requiring Power Factor Correction

\*For additional information on our Pb-Free strategy and soldering details, please download the ON Semiconductor Soldering and Mounting Techniques Reference Manual, SOLDERRM/D.

### MARKING DIAGRAM



- A = Assembly Location
- WL = Wafer Lot
- Y = Year
- WW = Work Week
- G = Pb-Free Package

### PIN ASSIGNMENT

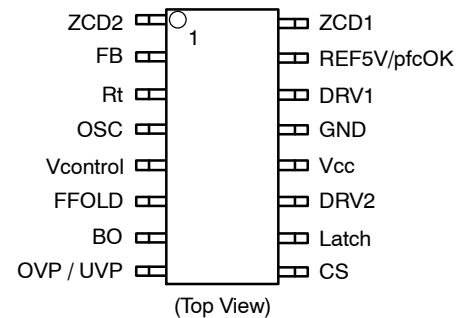

### ORDERING INFORMATION

Device	Package	Shipping†
NCP1631DR2G	SOIC-16 (Pb-Free)	2500 / Tape & Reel

†For information on tape and reel specifications, including part orientation and tape sizes, please refer to our Tape and Reel Packaging Specifications Brochure, [BRD8011/D](http://BRD8011/D).

# NCP1631

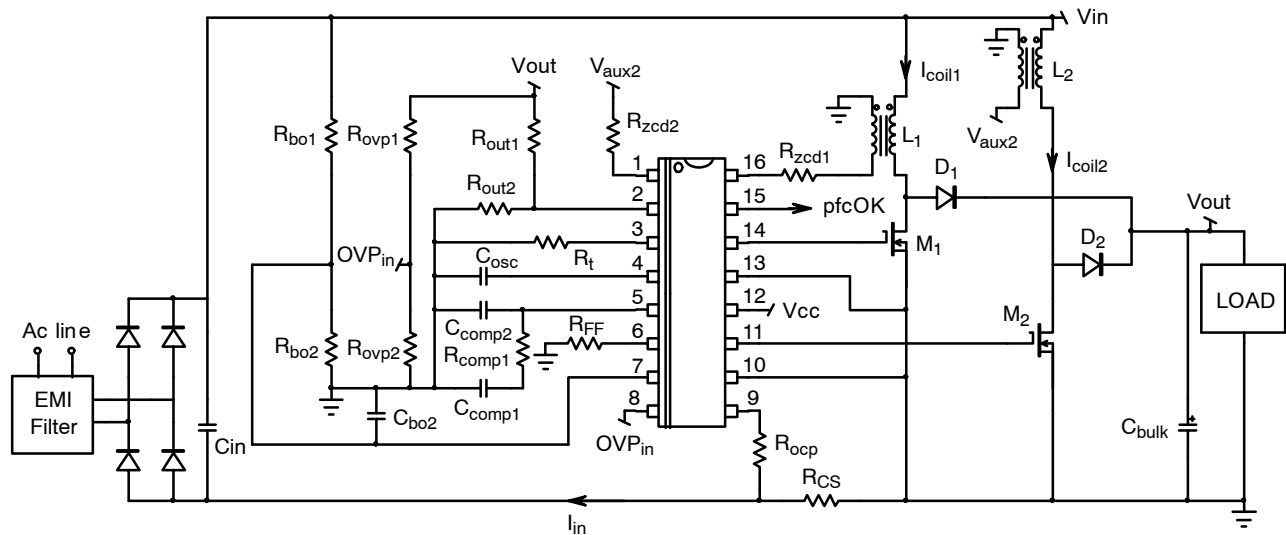

Figure 1. Typical Application Schematic

Table 1. MAXIMUM RATINGS

Symbol	Rating	Pin	Value	Unit
$V_{CC(MAX)}$	Maximum Power Supply Voltage Continuous	12	-0.3, +20	V
$DRV_{MAX}$	Maximum Voltage on DRV Pins	11, 14	-0.3 V, $V_{CC}$	V
$V_{MAX}$	Maximum Input Voltage on Low Power Pins	1, 2, 3, 4, 6, 7, 8, 9, 10, 15, and 16	-0.3, +9.0	V
$V_{Control(MAX)}$	$V_{Control}$ Pin Maximum Input Voltage	5	-0.3, $V_{Control(clamp)}$ (Note 1)	V
$P_D$ $R_{\theta J-A}$	Power Dissipation and Thermal Characteristics Maximum Power Dissipation @ $T_A = 70^\circ C$ Thermal Resistance Junction-to-Air		550 145	mW $^\circ C/W$
$T_J$	Operating Junction Temperature Range		-55 to +150	$^\circ C$
$T_{J(MAX)}$	Maximum Junction Temperature		150	$^\circ C$
$T_{S(MAX)}$	Storage Temperature Range		-65 to +150	$^\circ C$
$T_{L(MAX)}$	Lead Temperature (Soldering, 10s)		300	$^\circ C$
	ESD Capability, HBM model (Note 2)		3	kV
	ESD Capability, Machine Model (Note 2)		250	V

Stresses exceeding those listed in the Maximum Ratings table may damage the device. If any of these limits are exceeded, device functionality should not be assumed, damage may occur and reliability may be affected.

1. " $V_{Control(clamp)}$ " is the pin5 clamp voltage.
2. This device(s) contains ESD protection and exceeds the following tests:  
Human Body Model 2000 V per JEDEC Standard JESD22-A114E  
Machine Model Method 200 V per JEDEC Standard JESD22-A115-A
3. This device contains latch-up protection and exceeds 100 mA per JEDEC Standard JESD78.

# NCP1631

**Table 2. TYPICAL ELECTRICAL CHARACTERISTICS TABLE** (Conditions:  $V_{CC} = 15\text{ V}$ ,  $V_{pin7} = 2\text{ V}$ ,  $V_{pin10} = 0\text{ V}$ ; for typical values  $T_J = 25^\circ\text{C}$ , for min/max values  $T_J = -55^\circ\text{C}$  to  $+125^\circ\text{C}$ , unless otherwise specified) (Note 6)

Characteristics	Test Conditions	Symbol	Min	Typ	Max	Unit
<b>STARTUP AND SUPPLY CIRCUITS</b>						
Supply Voltage						V
Startup Threshold	$V_{CC}$ increasing	$V_{CC(on)}$	11	11.85	12.7	
Minimum Operating Voltage	$V_{CC}$ decreasing	$V_{CC(off)}$	9.5	10	10.5	
Hysteresis $V_{CC(on)} - V_{CC(off)}$		$V_{CC(hyst)}$	1.5	1.85	–	
Internal Logic Reset	$V_{CC}$ decreasing	$V_{CC(reset)}$	4.0	5.75	7.5	
Startup current	$V_{CC} = 9.4\text{ V}$	$I_{CC(start)}$	–	35	100	$\mu\text{A}$
Supply Current						$\text{mA}$
Device Enabled/No output load on pin6	$F_{sw} = 130\text{ kHz}$ (Note 4)	$I_{CC1}$	–	5.0	7.0	
Current that discharges $V_{CC}$ in latch mode	$V_{CC} = 15\text{ V}$ , $V_{pin10} = 5\text{ V}$	$I_{CC(latch)}$	–	0.4	0.8	
Current that discharges $V_{CC}$ in OFF mode	$V_{CC} = 15\text{ V}$ , pin 7 grounded	$I_{CC(off)}$	–	0.4	0.8	
<b>OSCILLATOR AND FREQUENCY FOLDBACK</b>						
Clamping Charging Current	Pin 6 open $T_J = -40^\circ\text{C}$ to $+125^\circ\text{C}$ $T_J = -55^\circ\text{C}$ to $+125^\circ\text{C}$ (Note 6)	$I_{OSC(clamp)}$	31.5 30	35 35	38.5 38.5	$\mu\text{A}$
Charge Current with no frequency foldback	Pin 6 grounded $T_J = -40^\circ\text{C}$ to $+125^\circ\text{C}$ $T_J = -55^\circ\text{C}$ to $+125^\circ\text{C}$ (Note 6)	$I_{OSC(CH1)}$	126 120	140 140	154 154	$\mu\text{A}$
Charge Current @ $I_{pin6} = 50\ \mu\text{A}$	$I_{pin6} = 50\ \mu\text{A}$	$I_{OSC(CH2)}$	76.5	85	93.5	$\mu\text{A}$
Maximum Discharge Current with no frequency foldback	Pin 6 grounded $T_J = -40^\circ\text{C}$ to $+125^\circ\text{C}$ $T_J = -55^\circ\text{C}$ to $+125^\circ\text{C}$ (Note 6)	$I_{OSC(DISCH1)}$	94.5 90	105 105	115.5 115.5	$\mu\text{A}$
Discharge Current @ $I_{pin6} = 50\ \mu\text{A}$	$I_{pin6} = 50\ \mu\text{A}$	$I_{OSC(DISCH2)}$	45	50	55	$\mu\text{A}$
Voltage on pin 6	$I_{pin6} = 50\ \mu\text{A}$ , $V_{pin5} = 2.5\text{ V}$	$V_{FF}$	0.9	1.0	1.3	V
Oscillator Upper Threshold		$V_{OSC(high)}$	–	5	–	V
Oscillator Lower Threshold		$V_{OSC(low)}$	3.6	4.0	4.4	V
Oscillator Swing (Note 5)		$V_{OSC(swing)}$	0.93	0.98	1.03	V
<b>CURRENT SENSE</b>						
Current Sense Voltage Offset	$I_{pin9} = 100\ \mu\text{A}$ $I_{pin9} = 10\ \mu\text{A}$	$V_{CS(TH100)}$ $V_{CS(TH10)}$	–20 –10	0 0	20 10	mV
Current Sense Protection Threshold	$T_J = 25^\circ\text{C}$ $T_J = -40^\circ\text{C}$ to $125^\circ\text{C}$ $T_J = -55^\circ\text{C}$ to $+125^\circ\text{C}$ (Note 6)	$I_{LIM1}$	202 194 173	210 210 210	226 226 226	$\mu\text{A}$
Threshold for In-rush Current Detection (Note 5)	$T_J = -40^\circ\text{C}$ to $+125^\circ\text{C}$ $T_J = -55^\circ\text{C}$ to $+125^\circ\text{C}$	$I_{in-rush}$	11 10.4	14 14	17 17	$\mu\text{A}$
<b>GATE DRIVE</b> (Note 7)						
Drive Resistance						$\Omega$
DRV1 Sink	$I_{pin14} = 100\text{ mA}$	$R_{SNK1}$	–	7	15	
DRV1 Source	$I_{pin14} = -100\text{ mA}$	$R_{SRC1}$	–	15	25	
DRV2 Sink	$I_{pin11} = 100\text{ mA}$	$R_{SNK2}$	–	7	15	
DRV2 Source	$I_{pin11} = -100\text{ mA}$	$R_{SRC2}$	–	15	25	

Product parametric performance is indicated in the Electrical Characteristics for the listed test conditions, unless otherwise noted. Product performance may not be indicated by the Electrical Characteristics if operated under different conditions.

4. DRV1 and DRV2 pulsating at half this frequency, that is, 65 kHz.
5. Not tested. Guaranteed by design and characterization.
6. For coldest temperature, QA sampling at  $-40^\circ\text{C}$  in production and  $-55^\circ\text{C}$  specification is Guaranteed by Characterization.
7. Guaranteed by design, the VCC pin can handle the double of the DRV peak source current, that is, 1 A typically.

# NCP1631

**Table 2. TYPICAL ELECTRICAL CHARACTERISTICS TABLE** (Conditions:  $V_{CC} = 15\text{ V}$ ,  $V_{pin7} = 2\text{ V}$ ,  $V_{pin10} = 0\text{ V}$ ; for typical values  $T_J = 25^\circ\text{C}$ , for min/max values  $T_J = -55^\circ\text{C}$  to  $+125^\circ\text{C}$ , unless otherwise specified) (Note 6)

Characteristics	Test Conditions	Symbol	Min	Typ	Max	Unit
<b>GATE DRIVE</b> (Note 7)						
Drive Current Capability (Note 5)						
DRV1 Sink	$V_{DRV1} = 10\text{ V}$	$I_{SNK1}$	–	800	–	mA
DRV1 Source	$V_{DRV1} = 0\text{ V}$	$I_{SRC1}$	–	500	–	
DRV2 Sink	$V_{DRV2} = 10\text{ V}$	$I_{SNK1}$	–	800	–	
DRV2 Source	$V_{DRV2} = 0\text{ V}$	$I_{SRC1}$	–	500	–	
Rise Time						ns
DRV1	$C_{DRV1} = 1\text{ nF}$ , $V_{DRV1} = 1\text{ to }10\text{ V}$	$t_{r1}$	–	40	–	
DRV2	$C_{DRV2} = 1\text{ nF}$ , $V_{DRV2} = 1\text{ to }10\text{ V}$	$t_{r2}$	–	40	–	
Fall Time						ns
DRV1	$C_{DRV1} = 1\text{ nF}$ , $V_{DRV1} = 10\text{ to }1\text{ V}$	$t_{f1}$	–	20	–	
DRV2	$C_{DRV2} = 1\text{ nF}$ , $V_{DRV2} = 10\text{ to }1\text{ V}$	$t_{f2}$	–	20	–	

## REGULATION BLOCK

Feedback Voltage Reference		$V_{REF}$	2.44	2.500	2.56	V
Error Amplifier Source Current Capability	@ $V_{pin2} = 2.4\text{ V}$	$I_{EA(SRC)}$		–20		$\mu\text{A}$
Error Amplifier Sink Current Capability	@ $V_{pin2} = 2.6\text{ V}$	$I_{EA(SNK)}$		+20		
Error Amplifier Gain		$G_{EA}$	110	200	290	$\mu\text{S}$
Pin 5 Source Current when ( $V_{out(low)}$ Detect) is activated	$T_J = -40^\circ\text{C}$ to $125^\circ\text{C}$ $T_J = -55^\circ\text{C}$ to $+125^\circ\text{C}$ (Note 6)	$I_{Control(boost)}$	184 178	230 230	276 276	$\mu\text{A}$ $\mu\text{A}$
Pin2 Bias Current	$V_{pin2} = 2.5\text{ V}$	$I_{FB(bias)}$	–500		500	nA
Pin 5 Voltage:	@ $V_{pin2} = 2.4\text{ V}$ @ $V_{pin2} = 2.6\text{ V}$	$V_{Control(clamp)}$ $V_{Control(MIN)}$ $V_{Control(range)}$	3.0 0 2.7	3.6 0.6 3	4.2 1.2 3.3	V
Internal $V_{REGUL}$ Voltage (measured on pin 6):	@ $V_{pin2} = 2.6\text{ V}$ , $I_{pin6} = 90\text{ }\mu\text{A}$ @ $V_{pin2} = 2.4\text{ V}$ , $I_{pin6} = 90\text{ }\mu\text{A}$	$V_{REGUL(MIN)}$ $V_{REGUL(Clamp)}$	– –	– 1.66	0.1 –	V
Ratio ( $V_{out(low)}$ Detect Threshold / $V_{REF}$ ) (Note 5)	FB falling	$V_{out(low)}/V_{REF}$	95.0	95.5	96.0	%
Ratio ( $V_{out(low)}$ Detect Hysteresis / $V_{REF}$ ) (Note 5)	FB rising	$H_{out(low)}/V_{REF}$	–	–	0.5	%

## SKIP MODE

Duty Cycle	$V_{pin2} = 3\text{ V}$	$D_{MIN}$	–	–	0	%
------------	-------------------------	-----------	---	---	---	---

## RAMP CONTROL (valid for the two phases)

Maximum DRV1 and DRV2 On-Time (FB pin grounded) $T_J = -25^\circ\text{C}$ to $+125^\circ\text{C}$	$V_{pin7} = 1.1\text{ V}$ , $I_{pin3} = 50\text{ }\mu\text{A}$	$t_{on1}$	14.5	19.5	22.5	$\mu\text{s}$
	$V_{pin7} = 1.1\text{ V}$ , $I_{pin3} = 200\text{ }\mu\text{A}$ (Note 5)	$t_{on2}$	1.10	1.35	1.60	
	$V_{pin7} = 2.2\text{ V}$ , $I_{pin3} = 100\text{ }\mu\text{A}$ (Note 5)	$t_{on3}$	4.00	5.00	6.00	
	$V_{pin7} = 2.2\text{ V}$ , $I_{pin3} = 400\text{ }\mu\text{A}$ (Note 5)	$t_{on4}$	0.35	0.41	0.48	
Maximum DRV1 and DRV2 On-Time (FB pin grounded) $T_J = -40^\circ\text{C}$ to $+125^\circ\text{C}$	$V_{pin7} = 1.1\text{ V}$ , $I_{pin3} = 50\text{ }\mu\text{A}$	$t_{on1}$	14.0	19.5	22.5	$\mu\text{s}$
	$V_{pin7} = 1.1\text{ V}$ , $I_{pin3} = 200\text{ }\mu\text{A}$ (Note 5)	$t_{on2}$	1.05	1.35	1.60	
	$V_{pin7} = 2.2\text{ V}$ , $I_{pin3} = 100\text{ }\mu\text{A}$ (Note 5)	$t_{on3}$	3.84	5.00	6.00	
	$V_{pin7} = 2.2\text{ V}$ , $I_{pin3} = 400\text{ }\mu\text{A}$ (Note 5)	$t_{on4}$	0.33	0.41	0.48	

Product parametric performance is indicated in the Electrical Characteristics for the listed test conditions, unless otherwise noted. Product performance may not be indicated by the Electrical Characteristics if operated under different conditions.

4. DRV1 and DRV2 pulsating at half this frequency, that is, 65 kHz.
5. Not tested. Guaranteed by design and characterization.
6. For coldest temperature, QA sampling at  $-40^\circ\text{C}$  in production and  $-55^\circ\text{C}$  specification is Guaranteed by Characterization.
7. Guaranteed by design, the VCC pin can handle the double of the DRV peak source current, that is, 1 A typically.

# NCP1631

**Table 2. TYPICAL ELECTRICAL CHARACTERISTICS TABLE** (Conditions:  $V_{CC} = 15\text{ V}$ ,  $V_{pin7} = 2\text{ V}$ ,  $V_{pin10} = 0\text{ V}$ ; for typical values  $T_J = 25^\circ\text{C}$ , for min/max values  $T_J = -55^\circ\text{C}$  to  $+125^\circ\text{C}$ , unless otherwise specified) (Note 6)

Characteristics	Test Conditions	Symbol	Min	Typ	Max	Unit
<b>RAMP CONTROL (valid for the two phases)</b>						
Maximum DRV1 and DRV2 On-Time (FB pin grounded) $T_J = -55^\circ\text{C}$ to $+125^\circ\text{C}$	$V_{pin7} = 1.1\text{ V}$ , $I_{pin3} = 50\text{ }\mu\text{A}$ (Note 6)	$t_{on1}$	13.0	19.5	22.5	$\mu\text{s}$
	$V_{pin7} = 1.1\text{ V}$ , $I_{pin3} = 200\text{ }\mu\text{A}$ (Note 5)	$t_{on2}$	1.00	1.35	1.60	
	$V_{pin7} = 2.2\text{ V}$ , $I_{pin3} = 100\text{ }\mu\text{A}$ (Note 5)	$t_{on3}$	3.70	5.00	6.00	
	$V_{pin7} = 2.2\text{ V}$ , $I_{pin3} = 400\text{ }\mu\text{A}$ (Note 5)	$t_{on4}$	0.32	0.41	0.48	
Pin 3 voltage	$V_{BO} = V_{pin7} = 1.1\text{ V}$ , $I_{pin3} = 50\text{ }\mu\text{A}$	$V_{Rt1}$	1.071	1.096	1.121	V
	$V_{BO} = V_{pin7} = 1.1\text{ V}$ , $I_{pin3} = 200\text{ }\mu\text{A}$	$V_{Rt2}$	1.071	1.096	1.121	
	$V_{BO} = V_{pin7} = 2.2\text{ V}$ , $I_{pin3} = 50\text{ }\mu\text{A}$	$V_{Rt3}$	2.169	2.196	2.223	
	$V_{BO} = V_{pin7} = 2.2\text{ V}$ , $I_{pin3} = 200\text{ }\mu\text{A}$	$V_{Rt4}$	2.169	2.196	2.223	
Maximum $V_{ton}$ Voltage	Not tested	$V_{ton(MAX)}$		5		V
Pin 3 Current Capability		$I_{Rt(MAX)}$	1	–	–	mA
Pin 3 sourced current below which the controller is OFF		$I_{Rt(off)}$		7		$\mu\text{A}$
Pin 3 Current Range	Not tested	$I_{Rt(range)}$	20		1000	$\mu\text{A}$
<b>ZERO VOLTAGE DETECTION CIRCUIT (valid for ZCD1 and ZCD2)</b>						
ZCD Threshold Voltage	$V_{ZCD}$ increasing	$V_{ZCD(TH),H}$	0.40	0.50	0.60	V
	$V_{ZCD}$ falling	$V_{ZCD(TH),L}$	0.20	0.25	0.30	
ZCD Hysteresis	$V_{ZCD}$ decreasing	$V_{ZCD(HYS)}$		0.25		V
Input Clamp Voltage	High State	$V_{ZCD(high)}$	9.0	11	13	V
	Low State	$V_{ZCD(low)}$	-1.1	-0.65	-0.1	
Internal Input Capacitance (Note 5)		$C_{ZCD}$	–	10	–	pF
ZCD Watchdog Delay		$t_{ZCD}$	80	200	320	$\mu\text{s}$
<b>BROWN-OUT DETECTION</b>						
Brown-Out Comparator Threshold		$V_{BO(TH)}$	0.97	1.00	1.03	V
Brown-Out Current Source	$T_J = -40^\circ\text{C}$ to $125^\circ\text{C}$	$I_{BO}$	6	7	8	$\mu\text{A}$
	$T_J = -55^\circ\text{C}$ to $+125^\circ\text{C}$ (Note 6)		5.7	7	8	
Brown-Out Blanking Time (Note 5)	$T_J = -40^\circ\text{C}$ to $125^\circ\text{C}$	$t_{BO(BLANK)}$	38	50	62	ms
	$T_J = -55^\circ\text{C}$ to $+125^\circ\text{C}$		38	50	63.5	
Brown-Out Monitoring Window (Note 5)		$t_{BO(window)}$	38	50	62	ms
Pin 7 clamped voltage if $V_{BO} < V_{BO(TH)}$ during $t_{BO(BLANK)}$	$I_{pin7} = -100\text{ }\mu\text{A}$	$V_{BO(clamp)}$	–	965	–	mV
Current Capability of the BO Clamp		$I_{BO(clamp)}$	100	–	–	$\mu\text{A}$
Hysteresis $V_{BO(TH)} - V_{BO(clamp)}$	$I_{pin7} = -100\text{ }\mu\text{A}$	$V_{BO(HYS)}$	10	35	60	mV
Current Capability of the BO pin Clamp PNP Transistor		$I_{BO(PNP)}$	100	–	–	$\mu\text{A}$
Pin BO voltage when clamped by the PNP	$I_{pin7} = -100\text{ }\mu\text{A}$	$V_{BO(PNP)}$	0.35	0.70	0.90	V
<b>OVER AND UNDER VOLTAGE PROTECTIONS</b>						
Over-Voltage Protection Threshold		$V_{OVP}$	2.425	2.500	2.575	V
Ratio ( $V_{OVP} / V_{REF}$ ) (Note 5)		$V_{OVP}/V_{REF}$	99.2	99.7	100.2	%
Ratio UVP Threshold over $V_{REF}$		$V_{UVP}/V_{REF}$	8	12	16	%

Product parametric performance is indicated in the Electrical Characteristics for the listed test conditions, unless otherwise noted. Product performance may not be indicated by the Electrical Characteristics if operated under different conditions.

4. DRV1 and DRV2 pulsating at half this frequency, that is, 65 kHz.
5. Not tested. Guaranteed by design and characterization.
6. For coldest temperature, QA sampling at  $-40^\circ\text{C}$  in production and  $-55^\circ\text{C}$  specification is Guaranteed by Characterization.
7. Guaranteed by design, the VCC pin can handle the double of the DRV peak source current, that is, 1 A typically.

# NCP1631

**Table 2. TYPICAL ELECTRICAL CHARACTERISTICS TABLE** (Conditions:  $V_{CC} = 15\text{ V}$ ,  $V_{pin7} = 2\text{ V}$ ,  $V_{pin10} = 0\text{ V}$ ; for typical values  $T_J = 25^\circ\text{C}$ , for min/max values  $T_J = -55^\circ\text{C}$  to  $+125^\circ\text{C}$ , unless otherwise specified) (Note 6)

Characteristics	Test Conditions	Symbol	Min	Typ	Max	Unit
-----------------	-----------------	--------	-----	-----	-----	------

## OVER AND UNDER VOLTAGE PROTECTIONS

Pin 8 Bias Current	$V_{pin8} = 2.5\text{ V}$ $V_{pin8} = 0.3\text{ V}$	$I_{OVP(bias)}$	-500	-	500	nA
--------------------	--	-----------------	------	---	-----	----

## LATCH INPUT

Pin Latch Threshold for Shutdown		$V_{Latch}$	2.375	2.500	2.625	V
Pin Latch Bias Current	$V_{pin10} = 2.3\text{ V}$	$I_{Latch(bias)}$	-500	-	500	nA

## pfcOK / REF5V

Pin 15 Voltage Low State	$V_{pin7} = 0\text{ V}$ , $I_{pin15} = 250\text{ }\mu\text{A}$	$V_{REF5V(low)}$	-	60	120	mV
Pin 15 Voltage High State	$V_{pin7} = 0\text{ V}$ , $I_{pin15} = 5\text{ mA}$	$V_{REF5V(high)}$	4.7	4.85	5.3	V
Current Capability		$I_{REF5V}$	5	10	-	mA

## THERMAL SHUTDOWN

Thermal Shutdown Threshold		$T_{SHDN}$	130	140	150	$^\circ\text{C}$
Thermal Shutdown Hysteresis		$T_{SHDN(HYS)}$	-	50	-	$^\circ\text{C}$

Product parametric performance is indicated in the Electrical Characteristics for the listed test conditions, unless otherwise noted. Product performance may not be indicated by the Electrical Characteristics if operated under different conditions.

4. DRV1 and DRV2 pulsating at half this frequency, that is, 65 kHz.
5. Not tested. Guaranteed by design and characterization.
6. For coldest temperature, QA sampling at  $-40^\circ\text{C}$  in production and  $-55^\circ\text{C}$  specification is Guaranteed by Characterization.
7. Guaranteed by design, the VCC pin can handle the double of the DRV peak source current, that is, 1 A typically.

# NCP1631

**Table 3. DETAILED PIN DESCRIPTION**

Pin Number	Name	Function
1	ZCD2	This is the zero current detection pin for phase 2 of the interleaved PFC stage. Apply the voltage from an auxiliary winding to detect the core reset of the inductor and the valley of the MOSFET drain source voltage
2	FB	This pin receives a portion of the pre-converter output voltage. This information is used for the regulation and the “output low” detection ( $V_{OUTL}$ ) that drastically speed-up the loop response when the output voltage drops below 95.5% of the wished level.
3	$R_T$	The resistor placed between pin 3 and ground adjusts the maximum on-time of our system for both phases, and hence the maximum power that can be delivered by the PFC stage.
4	OSC	Connect a capacitor to set the clamp frequency of the PFC stage. If wished, this frequency can be reduced in light load as a function of the resistor placed between pin 6 and ground (frequency fold-back). If the coil current cycle is longer than the selected switching period, the circuit delays the next cycle until the core is reset. Hence, the PFC stage can operate in Critical Conduction Mode in the most stressful conditions.
5	$V_{Control}$	The error amplifier output is available on this pin. The capacitor connected between this pin and ground adjusts the regulation loop bandwidth that is typically set below 20 Hz to achieve high Power Factor ratios. Pin5 is grounded when the circuit is off so that when it starts operation, the power increases slowly (soft-start).
6	Freq. Foldback	Apply a resistor between pin 6 and ground to adjust the oscillator charge current. Clamped not to exceed 100 $\mu$ A, this charge current is made proportional to the power level for a reduced switching frequency at light load and an optimum efficiency over the load range.
7	BO (Brown-out Protection)	Apply an averaged portion of the input voltage to detect brown-out conditions when $V_{pin2}$ drops below 1 V. A 50-ms internal delay blanks short mains interruptions to help meet hold-up time requirements. When it detects a brown-out condition, the circuit stops pulsing and grounds the “pfcOK” pin to disable the downstream converter. Also an internal 7- $\mu$ A current source is activated to offer a programmable hysteresis. The pin2 voltage is internally re-used for feed-forward. Grounding pin 7 disables the part (after the 50-ms blanking time has elapsed).
8	OVP / UVP	The circuit turns off when $V_{pin9}$ goes below 480 mV (UVP) and disables the drive as long as the pin voltage exceeds 2.5 V (OVP).
9	CS	This pin monitors a negative voltage proportional to the coil current. This signal is sensed to limit the maximum coil current and protect the PFC stage in presence of in-rush currents.
10	Latch	Apply a voltage higher than 2.5 V to latch-off the circuit. The device is reset by unplugging the PFC stage (practically when the circuit detects a brown-out detection) or by forcing the circuit $V_{CC}$ below $V_{CCRST}$ (4 V typically). Operation can then resume when the line is applied back.
11	DRV2	This is the gate drive pin for phase 2 of the interleaved PFC stage. The high current capability of the totem pole gate drive (+0.5/-0.8 A) makes it suitable to effectively drive high gate charge power MOSFETs.
12	$V_{CC}$	This pin is the positive supply of the IC. The circuit starts to operate when $V_{CC}$ exceeds 12 V and turns off when $V_{CC}$ goes below 10 V (typical values). After start-up, the operating range is 9.5 V up to 20 V.
13	GND	Connect this pin to the pre-converter ground.
14	DRV1	This is the gate drive pin for phase 1 of the interleaved PFC stage. The high current capability of the totem pole gate drive (+0.5/-0.8 A) makes it suitable to effectively drive high gate charge power MOSFETs.
15	REF5V / pfcOK	The pin15 voltage is high (5 V) when the PFC stage is in a normal, steady state situation and low otherwise. This signal serves to “inform” the downstream converter that the PFC stage is ready and that hence, it can start operation.
16	ZCD1	This is the zero current detection pin for phase 1 of the interleaved PFC stage. Apply the voltage from an auxiliary winding to detect the core reset of the inductor and the valley of the MOSFET drain source voltage.

# NCP1631

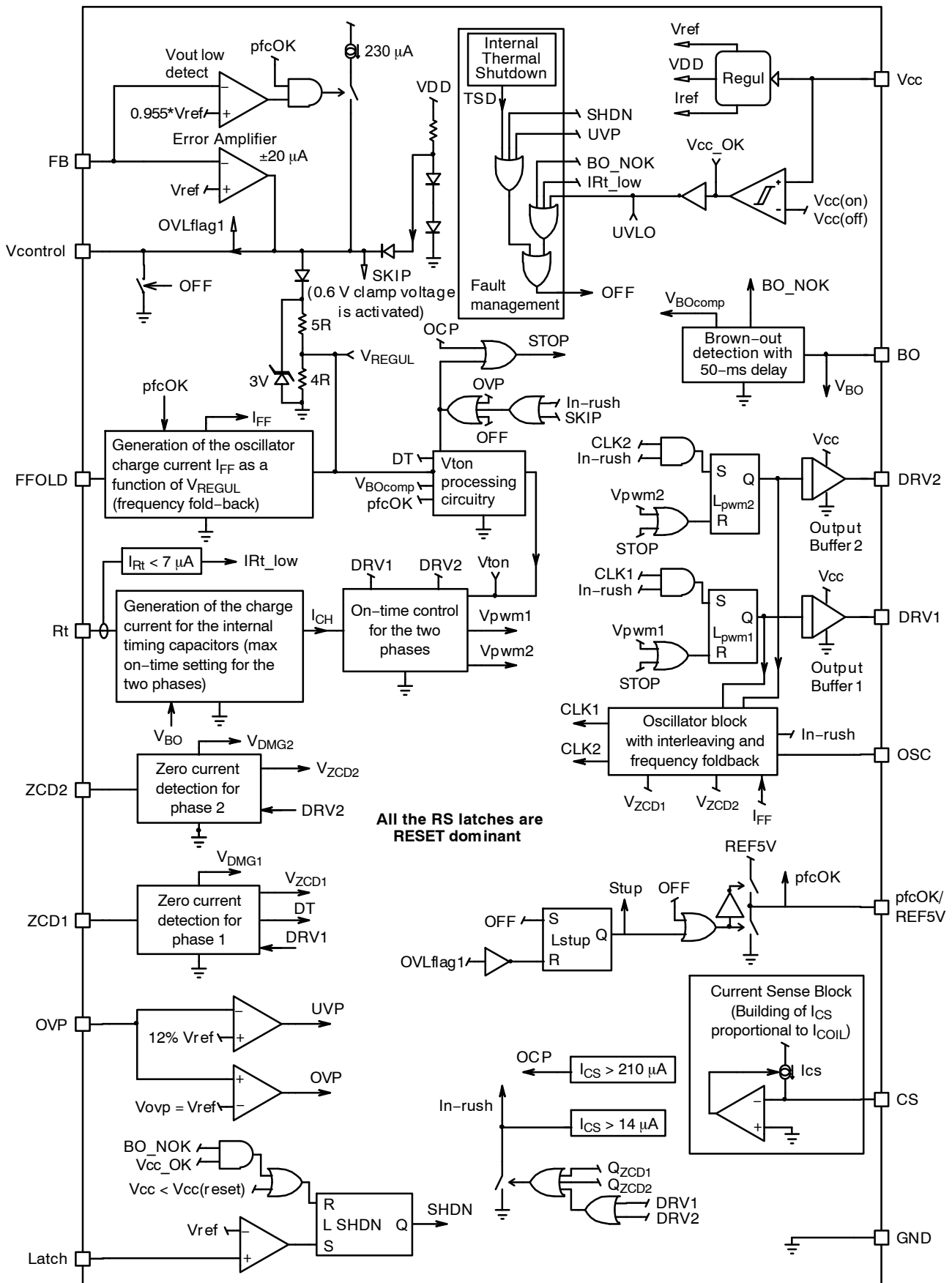

**Figure 2. Functional Block Diagram**

### Detailed Operating Description

The NCP1631 integrates a dual MOSFET driver for interleaved, 2-phase PFC applications. It drives the two branches in so-called *Frequency Clamped Critical conduction Mode (FCCrM)* where each phase operates in *Critical conduction Mode (CrM)* in the most stressful conditions and in *Discontinuous Conduction Mode (DCM)* otherwise, acting as a CrM controller with a frequency clamp (given by the oscillator). According to the conditions, the PFC stage actually jumps from DCM to CrM (and vice versa) with no discontinuity in operation and without degradation of the current shape.

Furthermore, the circuit incorporates protection features for a rugged operation together with some special circuitry to lower the power consumed by the PFC stage in no-load conditions. More generally, the NCP1631 is ideal in systems where cost-effectiveness, reliability, low stand-by power and high power factor are the key parameters:

#### Fully Stable FCCrM and Out-Of-Phase Operation.

Unlike master/slave controllers, the NCP1631 utilizes an interactive-phase approach where the two branches operate independently. Hence, the two phases necessarily operate in FCCrM, preventing risks of undesired dead-times or continuous conduction mode sequences. In addition, the circuit makes them interact so that they run out-of-phase. The NCP1631 unique interleaving technique substantially maintains the wished 180° phase shift between the 2 branches, in all conditions including start-up, fault or transient sequences.

#### Optimized Efficiency Over The Full Power Range.

The NCP1631 optimizes the efficiency of your PFC stage in the whole line/load range. Its clamp frequency is a major contributor at nominal load. For medium and light load, the clamp frequency linearly decays as a function of the power to maintain high efficiency levels even in very light load. The power threshold under which frequency reduces is programmed by the resistor placed between pin 6 and ground. To prevent any risk of regulation loss at no load, the circuit further skips cycles when the error amplifier reaches its low clamp level.

#### Fast Line / Load Transient Compensation.

Characterized by the low bandwidth of their regulation loop, PFC stages exhibit large over and under-shoots when abrupt load or line transients occur (e.g. at start-up). The NCP1631 dramatically narrows the output voltage range. First, the controller dedicates one pin to set an accurate Over-Voltage Protection level and interrupts the power delivery as long as the output voltage exceeds this threshold. Also, the NCP1631 *dynamic response enhancer* drastically speeds-up the regulation loop when the output voltage is 4.5% below its desired level. As a matter of fact, a PFC stage provides the downstream converter with a very narrow voltage range.

#### A “pfcOK” signal.

The circuit detects when the PFC stage is in steady state or if on the contrary, it is in a start-up or fault condition. In the first case, the “pfcOK” pin (pin15) is in high state and low otherwise. This signal is to disable the downstream converter unless the bulk capacitor is charged and no fault is detected. Finally, the downstream converter can be optimally designed for the narrow voltage provided by the PFC stage in normal operation.

#### Safety Protections.

The NCP1631 permanently monitors the input and output voltages, the input current and the die temperature to protect the system from possible over-stresses and make the PFC stage extremely robust and reliable. In addition to the aforementioned OVP protection, one can list:

**Maximum Current Limit:** the circuit permanently senses the total input current and prevents it from exceeding the preset current limit, still maintaining the out-of-phase operation.

**In-rush Detection:** the NCP1631 prevents the power switches turn on for the large in-rush currents sequence that occurs during the start-up phase.

**Under-Voltage Protection:** this feature is mainly to prevent operation in case of a failure in the OVP monitoring network (e.g., bad connection).

**Brown-Out Detection:** the circuit stops operating if the line magnitude is too low to protect the PFC stage from the excessive stress that could damage it in such conditions.

**Thermal Shutdown:** the circuit stops pulsing when its junction temperature exceeds 150°C typically and resumes operation once it drops below about 100°C (50°C hysteresis).

#### NCP1631 Operating Modes

The NCP1631 drives the two branches of the interleaved in *FCCrM* where each phase operates in *Critical conduction Mode (CrM)* in the most stressful conditions and in *Discontinuous Conduction Mode (DCM)* otherwise, acting as a CrM controller with a frequency clamp (given by the oscillator). According to the conditions, the PFC stage actually jumps from DCM to CrM (and vice versa) with no discontinuity in operation and without degradation of the current shape.

The circuit can also transition within an ac line cycle so that:

- CrM reduces the current stress around the sinusoid top.
- DCM limits the frequency around the line zero crossing.

This capability offers the best of each mode without the drawbacks. The way the circuit modulates the MOSFET on-time allows this facility.

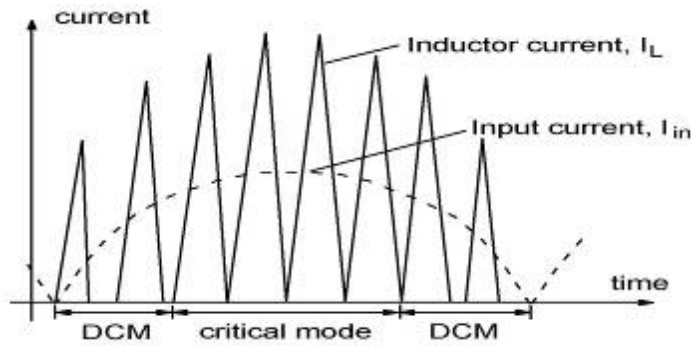

Figure 3. DCM and CRM Operation Within a Sinusoid Cycle for One Branch

**NCP1631 On-time Modulation**

Let’s study the ac line current absorbed by one phase of the interleaved PFC converter.

The current waveform of the inductor (L) during one switching period ( $T_{sw}$ ) is portrayed by Figure 5.

The ac line current is the averaged value of the coil current as the result of the EMI filter “polishing” action. Hence, the line current produced by one of the phase is:

$$I_{in} = \frac{1}{2} \left( \frac{t_1}{L} \right) \left( \frac{t_1 + t_2}{T_{sw}} \right) V_{in} \quad (\text{eq. 1})$$

Where ( $T_{sw} = t_1 + t_2 + t_3$ ) is the switching period and  $V_{in}$  is the ac line rectified voltage.

Equation 1 shows that  $I_{in}$  is proportional to  $V_{in}$  if

$\left( \frac{t_1(t_1 + t_2)}{T_{sw}} \right)$  is a constant.

Forcing  $\left( \frac{t_1(t_1 + t_2)}{T_{sw}} \right)$

constant is what the NCP1631 does to perform **FCCrM** operation that is, to operate in discontinuous or critical conduction mode according to the conditions, without degradation of the power factor.

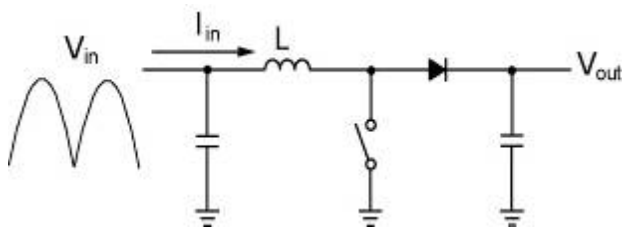

Figure 4. Boost Converter

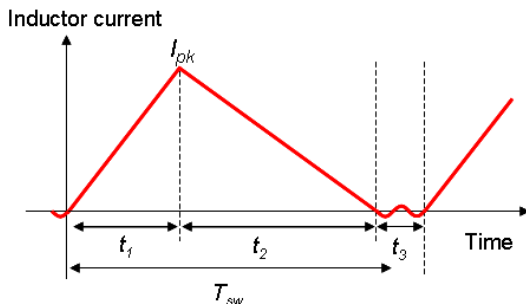

Figure 5. Inductor Current in DCM

The NCP1631 operates in voltage mode. As portrayed by Figure 6, the MOSFET on time  $t_1$  is controlled by the signal  $V_{ton}$  generated by the regulation block as follows:

$$t_1 = \frac{C_t V_{TON}}{I_t} \quad (\text{eq. 2})$$

Where:

- $C_t$  is the internal timing capacitor
- $I_t$  is the internal current source for the timing capacitor.

The  $I_t$  charge current is constant for a given resistor placed on the  $R_t$  pin.  $C_t$  is also a constant. Hence, the condition

$$\left( \frac{t_1(t_1 + t_2)}{T_{sw}} \right)$$

to be a constant for proper power factor correction can be changed into:

$$\left( \frac{V_{TON}(t_1 + t_2)}{T_{sw}} \right) \text{ is constant.}$$

The output of the regulation block ( $V_{CONTROL}$ ) is linearly changed into a signal ( $V_{REGUL}$ ) varying between 0 and 1.66 V. ( $V_{REGUL}$ ) is the voltage that is injected into the PWM section to modulate the MOSFET duty-cycle. However, the NCP1631 inserts some circuitry that processes ( $V_{REGUL}$ ) to form the signal ( $V_{TON}$ ) that is used in the PWM section instead of ( $V_{REGUL}$ ) (see Figure 7). ( $V_{TON}$ ) is modulated in response to the dead-time sensed during the precedent current cycles, that is, for a proper shaping of the ac line current. This modulation leads to:

$$V_{TON} = \frac{T_{sw} V_{REGUL}}{t_1 + t_2} \quad \text{or:} \quad V_{TON} \frac{t_1 + t_2}{T_{sw}} = V_{REGUL} \quad (\text{eq. 3})$$

Substitution of Equation 3 into Equation 2 leads to the following on-time expression:

$$t_1 = \frac{C_t \left( \frac{T_{sw} V_{REGUL}}{t_1 + t_2} \right)}{I_t} \quad (\text{eq. 4})$$

Replacing “ $t_1$ ” by its expression of Equation 4, Equation 1 simplifies as follows:

$$I_{in(\text{phase1})} = I_{in(\text{phase2})} = \frac{V_{in} C_t V_{REGUL}}{2L I_t} \quad (\text{eq. 5})$$

Given the regulation low bandwidth of the PFC systems, ( $V_{CONTROL}$ ) and then ( $V_{REGUL}$ ) are slow varying signals. Hence, the line current absorbed by each phase is:

$$I_{in(phase1)} = I_{in(phase2)} = k V_{in} \quad (eq. 6)$$

$$\text{where: } k = \text{constant} = \left[ \frac{C_t V_{REGUL}}{2 L I_t} \right]$$

Hence, the input current is then proportional to the input voltage and the ac line current is properly shaped.

One can note that this analysis is also valid for CrM operation that is just a particular case of this functioning where ( $t_3=0$ ), which leads to ( $t_1+t_2=T_{sw}$ ) and ( $V_{TON}=V_{REGUL}$ ). That is why the NCP1631 automatically adapts to the conditions and jumps from DCM and CrM (and vice versa) without power factor degradation and without discontinuity in the power delivery.

The charging current  $I_t$  is internally processed to be proportional to the square of the line magnitude. Its value is however programmed by the pin 3 resistor to adjust the available on-time as defined by the  $T_{on1}$  to  $T_{on4}$  parameters of the data sheet.

From these data, we can deduce:

$$t_1 = T_{on}(\mu s) = 50 n \frac{R_t^2}{V_{pin7}^2} \quad (eq. 7)$$

From this equation, we can check that if  $V_{pin7}$  (BO voltage) is 1 V and  $R_t$  is 20 k $\Omega$  ( $I_{pin3} = 50 \mu A$ ) that the on-time is 20  $\mu s$  as given by parameter  $T_{on1}$ .

Since:

$$V_{REGUL(max)} = 1.66 V$$

$$T_{on} = \frac{C_t V_{REGUL}}{I_t}$$

$$V_{pin7} = \frac{2\sqrt{2} V_{in(rms)} k_{BO}}{\pi}$$

where  $k_{BO}$  is the scale down factor of the BO sensing network

$$\left( k_{BO} = \frac{R_{bo2}}{R_{bo1} + R_{bo2}} \right)$$

(see Brown-out section)

We can deduce the total input current value and the average input power:

$$I_{in(rms)} \cong \frac{(R_t)^2 V_{REGUL}}{26.9 \cdot 10^{12} L k_{BO}^2 V_{in,rms}} \quad (eq. 8)$$

$$P_{in,avg} \cong \frac{(R_t)^2 V_{REGUL}}{26.9 \cdot 10^{12} L k_{BO}^2} \quad (eq. 9)$$

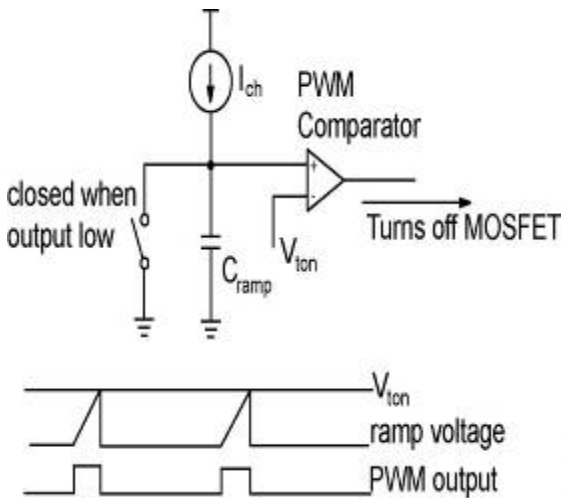
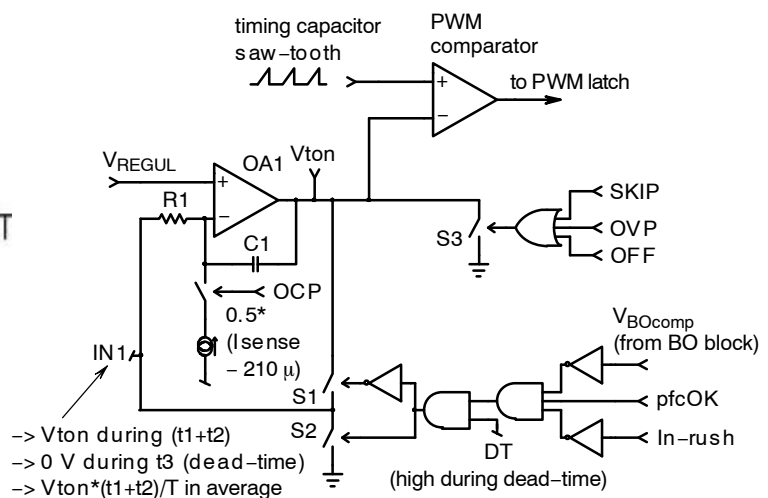

Figure 6. PWM Circuit and Timing Diagram

The “ $V_{TON}$  processing circuit” is “informed” when there is an OVP condition or a skip sequence, not to over-dimension  $V_{TON}$  in that conditions. Otherwise, an OVP sequence or a skipped cycle would be viewed as a “normal” dead-time phase by the circuit and  $V_{TON}$  would inappropriately increase to compensate it. (Refer to Figure 7).



The integrator OA1 amplifies the error between  $V_{REGUL}$  and  $IN1$  so that in average,  $(V_{TON} * (t_1+t_2) / T_{sw})$  equates  $V_{REGUL}$ .

Figure 7.  $V_{TON}$  Processing Circuit

The output of the “ $V_{TON}$  processing circuit” is also grounded when the circuit is in OFF state to discharge the capacitor  $C1$  and initialize it for the next active phase.

Finally, the “ $V_{TON}$ ” is not allowed to be further increased compared to  $V_{REGUL}$  when the circuit has not completed the start-up phase (pfcOK low) and if  $V_{BOcomp}$  from the brown-out block is high (refer to brown-out section for more information).

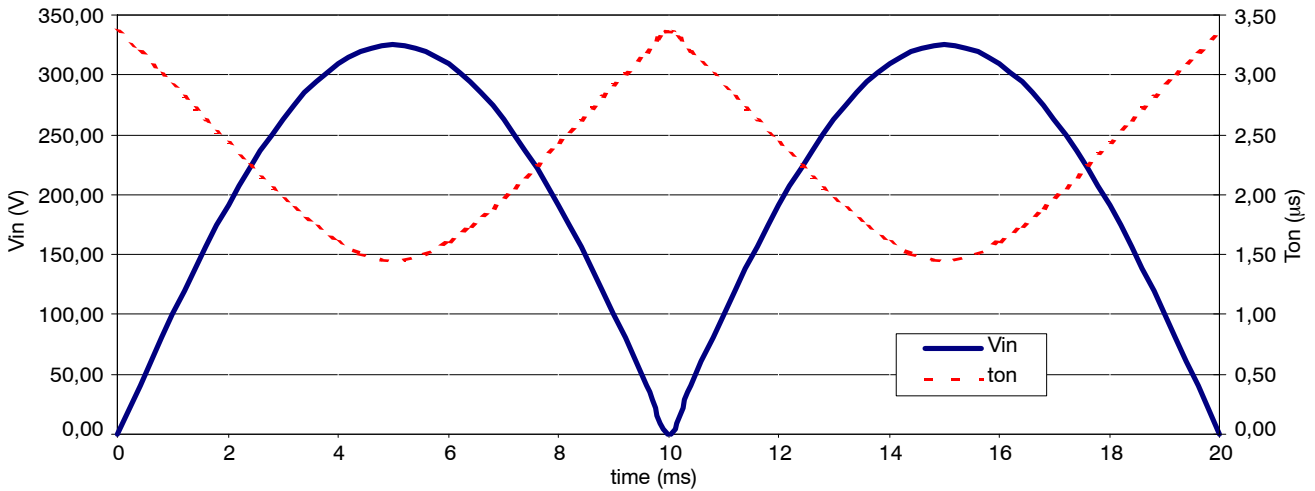

Figure 8. Input Voltage and On-time vs. Time (example with  $F_{SW} = 100 \text{ kHz}$ ,  $P_{in} = 150 \text{ W}$ ,  $V_{AC} = 230 \text{ V}$ ,  $L = 200 \mu\text{H}$ )

**Regulation Block and Low Output Voltage Detection**

A trans-conductance error amplifier with access to the inverting input and output is provided. It features a typical trans-conductance gain of  $200 \mu\text{S}$  and a typical capability of  $\pm 20 \mu\text{A}$ . The output voltage of the PFC stage is typically scaled down by a resistors divider and monitored by the inverting input (feed-back pin – pin2). The bias current is minimized (less than  $500 \text{ nA}$ ) to allow the use of a high impedance feed-back network. The output of the error amplifier is pinned out for external loop compensation (pin5). Typically a type-2 compensator is applied between pin5 and ground, to set the regulation bandwidth below  $20 \text{ Hz}$ , as need in PFC applications (refer to application note AND8407).

The swing of the error amplifier output is limited within an accurate range:

- It is forced above a voltage drop ( $V_F$ ) by the “low clamp” circuitry. When this circuitry is activated, the power demand is minimum and the NCP1631 enters skip mode (the controller stops pulsating) until the clamp is no more active.
- It is clamped not to exceed  $3.0 \text{ V} +$  the same  $V_F$  voltage drop.

Hence,  $V_{pin5}$  features a  $3 \text{ V}$  voltage swing.  $V_{pin5}$  is then offset down by ( $V_F$ ) and further divided before it connects to the “ $V_{ton}$  processing block” and the PWM section. Finally, the output of the regulation is a signal (“ $V_{REGUL}$ ” of the block diagram) that varies between  $0$  and  $1.66 \text{ V}$ .

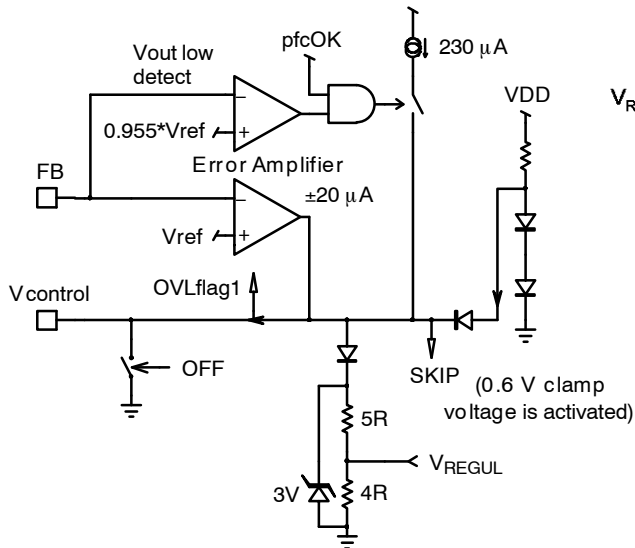

Figure 9. Regulation Block

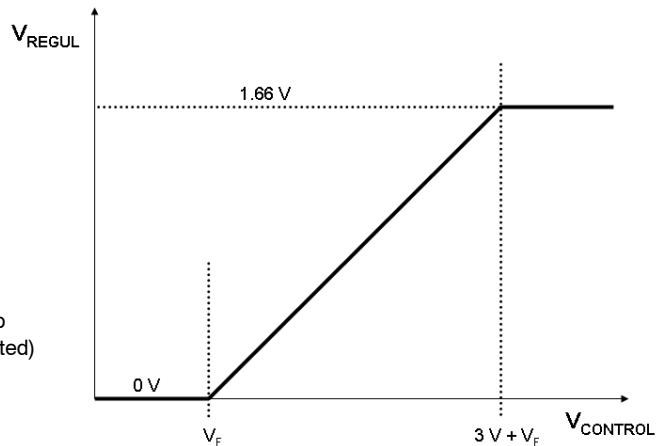

Figure 10. Correspondence Between  $V_{CONTROL}$  and  $V_{REGUL}$

Provided the low bandwidth of the regulation loop, sharp variations of the load, may result in excessive over and under-shoots. Over-shoots are limited by the Over-Voltage Protection (see OVP section). To contain the under-shoots, an internal comparator monitors the feed-back signal ( $V_{pin2}$ ) and when  $V_{pin2}$  is lower than 95.5% of its nominal value, it connects a 230  $\mu$ A current source to speed-up the charge of the compensation capacitor ( $C_{pin5}$ ). Finally, it is like if the comparator multiplied the error amplifier gain by 10.

One must note that this circuitry for under-shoots limitation, is not enabled during the start-up sequence of the PFC stage but only once the converter has stabilized (that is when the “pfcOK” signal of the block diagram, is high). This is because, at the beginning of operation, the pin5 capacitor must charge slowly and gradually for a soft start-up.

**Zero Current Detection**

While the on time is constant, the core reset time varies with the instantaneous input voltage. The NCP1631 determines the demagnetization completion by sensing the inductor voltage, more specifically, by detecting when the inductor voltage drops to zero.

Practically, an auxiliary winding in flyback configuration is taken off of the boost inductor and gives a scaled down version of the inductor voltage that is usable by the controller (Figure 12). In that way, the ZCD voltage (“ $V_{AUX}$ ”) falls and starts to ring around zero volts when the inductor current drops to zero. The NCP1631 detects this falling edge and allows the next driver on time.

Figure 1 shows how it is implemented.

For each phase, a comparator detects when the voltage of the ZCD winding exceeds 0.5 V. When this is the case, the coil is in demagnetization phase and the latch  $L_{ZCD}$  is set. This latch is reset when the next driver pulse occurs.

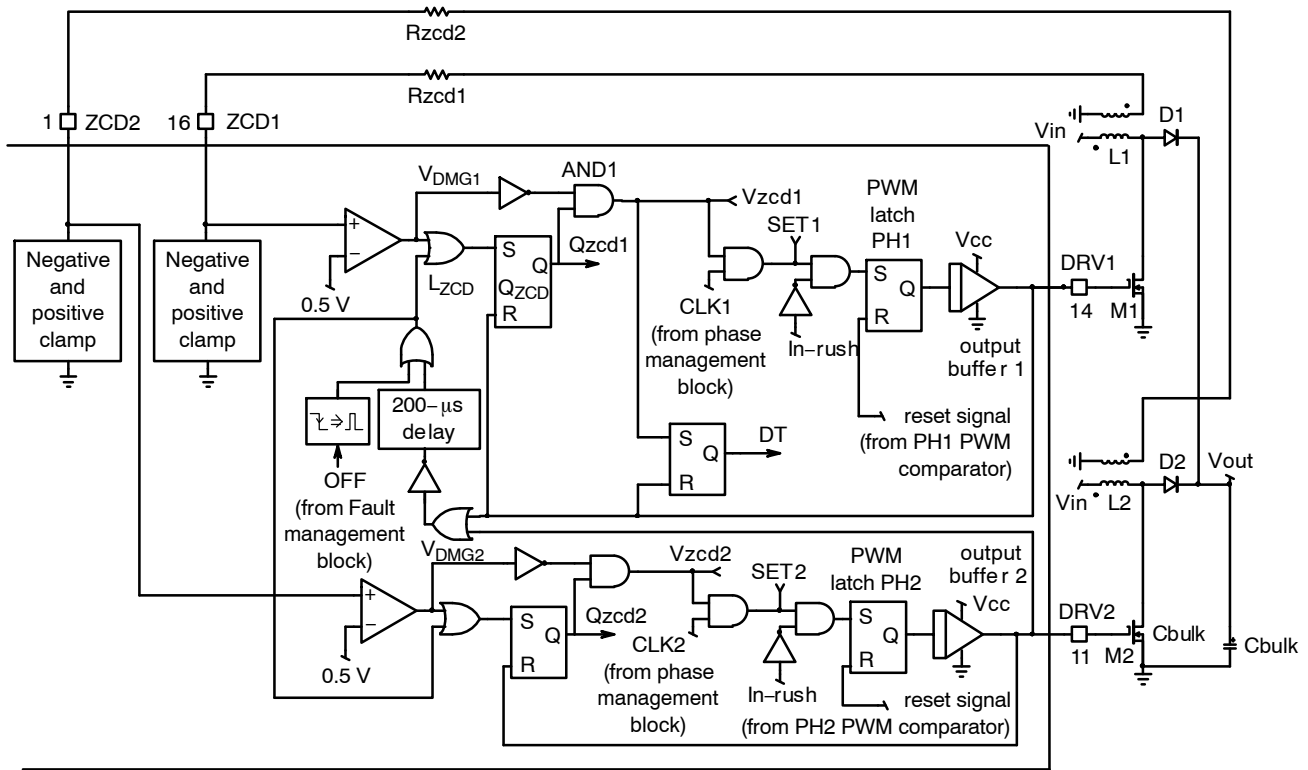

**Figure 11. Zero Current Detection**

To prevent negative voltages on the ZCD pins (ZCD1 for phase 1 and ZCD2 for phase 2), these pins are internally clamped to about 0 V when the voltage applied by the corresponding ZCD winding is negative. Similarly, the ZCD pins are clamped to  $V_{ZCD(high)}$  (10 V typical), when the ZCD voltage rises too high. Because of these clamps, a resistor ( $R_{ZCD}$  of Figure 11) is necessary to limit the current from the ZCD winding to the ZCD pin. The clamps are designed to respectively source and sink 5 mA minimum. It is recommended not to exceed this 5 mA level within the ZCD clamps for a proper operation.

At startup or after an inactive period (because of a protection that has tripped for instance), there is no energy in the ZCD winding and therefore no voltage signal to activate the ZCD comparator. This means that the driver will never turn on. To avoid this, an internal watchdog timer is integrated into the controller. If the driver remains low for more than 200  $\mu$ s (typical), the timer sets the  $L_{ZCD}$  latch as the ZCD winding signal would do. Obviously, this 200- $\mu$ s delay acts as a minimum off-time if there is no demagnetization winding while it has no action if there is a ZCD voltage provided by the auxiliary winding.

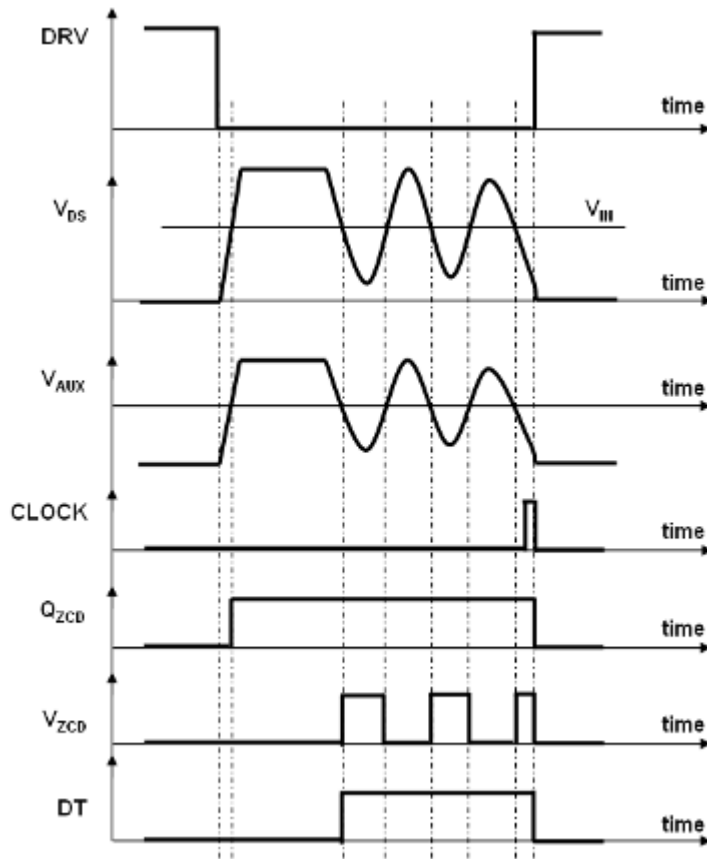

**Figure 12. Zero Current Detection Timing Diagram**  
( $V_{AUX}$  is the Voltage Provided by the ZCD Winding)

**Current Sense**

The NCP1631 is designed to monitor a negative voltage proportional to total input current, i.e., the current drawn by the two interleaved branches ( $I_{in}$ ). As portrayed by Figure 13, a current sense resistor ( $R_{CS}$ ) is practically inserted within the return path to generate a negative voltage ( $V_{CS}$ ) proportional to  $I_{in}$ . The circuit uses  $V_{CS}$  to detect when  $I_{in}$  exceeds its maximum permissible level. To do so, the circuit incorporates an operational amplifier that sources the current necessary to maintain the CS pin voltage null (refer to Figure 13). By inserting a resistor  $R_{OCP}$  between the CS pin and  $R_{CS}$ , we adjust the current that is sourced by the CS pin ( $I_{CS}$ ) as follows:

$$- [R_{CS}I_{COIL}] + [R_{OCP}I_{CS}] = 0 \quad (\text{eq. 10})$$

Which leads to:

$$I_{CS} = \frac{R_{CS}}{R_{OCP}} I_{COIL} \quad (\text{eq. 11})$$

In other words, the pin 9 current ( $I_{CS}$ ) is proportional to the coil current.

A negative clamp protects the circuit from the possible negative voltage that can be applied to the pin. This protection is permanently active (even if the circuit off). The clamp is designed to sustain 5 mA. It is recommended

not to sink more than 5 mA from the CS pin for a proper operation.

Two functions use  $I_{CS}$ : the over current protection and the in-rush current detection.

**Over-Current Protection (OCP)**

If  $I_{CS}$  exceeds  $I_{LIM1}$  (210  $\mu\text{A}$  typical), an over-current is detected and the on-time is decreased proportionally to the difference between the sensed current  $I_{IN}$  and the 210  $\mu\text{A}$  OCP threshold.

The on-time reduction is done by injecting a current  $I_{neg}$  in the negative input of the “ $V_{TON}$  processing circuit” OPAMP. (See Figure 7)

$$I_{neg} = 0.5(I_{CS} - 210 \mu) \quad (\text{eq. 12})$$

This current is injected each time the OCP signal is high.

The maximum coil current is:

$$I_{COIL(max)} = \frac{R_{OCP}}{R_{CS}} I_{LIM1} \quad (\text{eq. 13})$$

**In-rush Current Detection**

When the PFC stage is plugged to the mains, the bulk capacitor is abruptly charged to the line voltage. The charge current (named in-rush current) can be very huge

depending on the presence or absence of an effective in-rush limiting circuitry. If the MOSFET turns on during this severe transient, it may be over-stressed and finally damaged. That is why, the NCP1631 permanently monitors the input current and delays the MOSFET turn on until the in-rush current has vanished. This is the function of the  $I_{CS}$  comparison to the  $I_{in-rush}$  threshold ( $14 \mu A$  typical). When  $I_{CS}$  exceeds  $I_{in-rush}$ , the comparator output (“In-rush”) is high and prevents the PWM latches from setting (see block diagram). Hence, the two drivers cannot turn high and the MOSFETs cannot switch on. This is to guarantee that the MOSFETs remain off as long as if the input current exceeds 10% of its maximum value. This feature protects the

MOSFETs from the possible excessive stress it could suffer from if it was allowed to turn on while a huge current flowed through the coil as it can be the case at start-up or during an over-load transient.

The propagation delay ( $I_{CS} < I_{in-rush}$ ) to (drive outputs high) is in the range of few  $\mu s$ .

However when the circuit starts to operate, the NCP1631 disables this protection to avoid that the current produced by one phase and sensed by the circuit prevents the other branch from operating. Practically, some logic grounds the In-rush protection output when it detects the presence of current cycles with a zero current detection signal provided by the auxiliary winding (Figure 13).

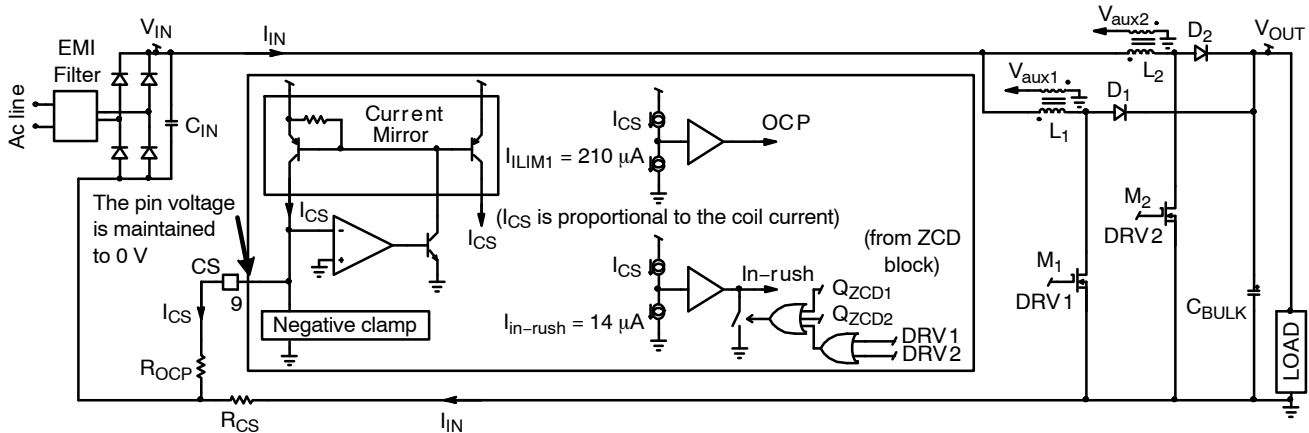

The CS block performs the over-current protection and the in-rush current detection.

Figure 13. Current Sense Block

**Over-Voltage Protection**

While PFC circuits often use one single pin for both the Over-Voltage Protection (OVP) and the feed-back, the NCP1631 dedicates one specific pin for the under-voltage and over-voltage protections. The NCP1631 configuration

allows the implementation of two separate feed-back networks (see Figure 15):

1. One for regulation applied to pin 2.
2. Another one for the OVP function (pin 8).

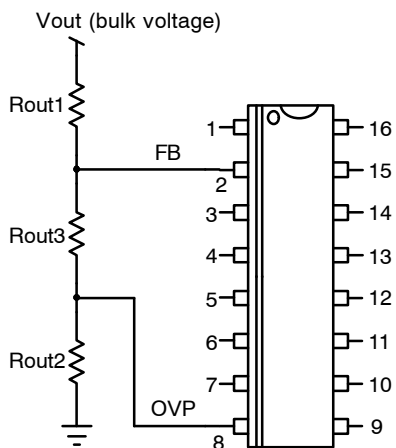

Figure 14. Configuration with One Feed-back Network for Both OVP and Regulation

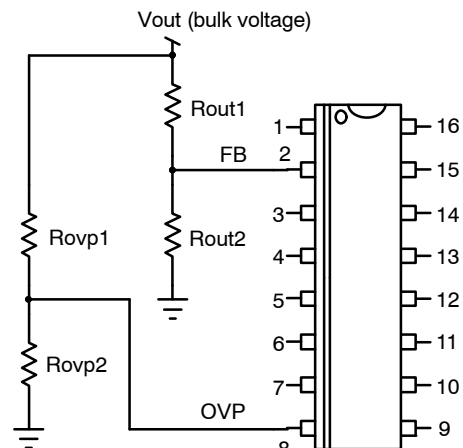

Figure 15. Configuration with Two Separate Feed-back Networks

The double feed-back configuration offers some up-graded safety level as it protects the PFC stage even if there is a failure of one of the two feed-back arrangements.

However, if wished, one single feed-back arrangement is possible as portrayed by Figure 14. The regulation and OVP blocks having the same reference voltage, the resistance ratio  $R_{out2}$  over  $R_{out3}$  adjusts the OVP threshold. More specifically,

The bulk regulation voltage (“ $V_{out(nom)}$ ”) is:

$$V_{out(nom)} = \frac{R_{out1} + R_{out2} + R_{out3}}{R_{out2} + R_{out3}} \cdot V_{ref} \quad (\text{eq. 14})$$

The OVP level (“ $V_{out(ovp)}$ ”) is:

$$V_{out(ovp)} = \frac{R_{out1} + R_{out2} + R_{out3}}{R_{out2}} \cdot V_{ref} \quad (\text{eq. 15})$$

The ratio OVP level over regulation level is:

$$\frac{V_{out(ovp)}}{V_{out(nom)}} = 1 + \frac{R_{out3}}{R_{out2}} \quad (\text{eq. 16})$$

For instance, ( $V_{out(nom)} = 105\% \times V_{out(nom)}$ ) leads to: ( $R_{out3} = 5\% \times R_{out2}$ ).

When the circuit detects that the output voltage exceeds the OVP level, it maintains the power switch open to stop the power delivery.

As mentioned previously, the “ $V_{TON}$  processing circuit” is “informed” when there is an OVP condition, not to over-dimension  $V_{TON}$  in that conditions. Otherwise, an OVP sequence would be viewed as a dead-time phase by the circuit and  $V_{TON}$  would inappropriately increase to compensate it (refer to Figure 7).

### PfcOK / REF5V Signal

The NCP1631 can communicate with the downstream converter. The signal “pfcOK/REF5V” is high (5 V) when the PFC stage is in normal operation (its output voltage is stabilized at the nominal level) and low otherwise.

More specifically, “pfcOK/REF5V” is low:

- During the PFC stage start-up, that is, as long as the output voltage has not yet stabilized at the right level. The start-up phase is detected by the latch “ $L_{STUP}$ ” of the block diagram in Figure 2. “ $L_{STUP}$ ” is set during each “off” phase so that its output (“ $STUP$ ”) is high when the circuit enters an active phase. The latch is reset when the error amplifier stops charging its output capacitor, that is, when the output voltage of the PFC stage has reached its desired regulation level. At that moment, “ $STUP$ ” falls down to indicate the end of the start-up phase.
- Any time, the circuit is off or a fault condition is detected as described by the “Fault management and OFF mode” section

Finally, “pfcOK/REF5V” is high when the PFC output voltage is properly and safely regulated. “pfcOK/REF5V”

should be used to allow operation of the downstream converter.

### Oscillator Section – Phase Management

The oscillator generates the clock signal that dictates the maximum switching frequency for the global system ( $f_{osc}$ ). In other words, each of the two interleaved branches cannot operate above the clamp frequency that is half the oscillator frequency ( $f_{osc}/2$ ). The oscillator frequency ( $f_{osc}$ ) is adjusted by the capacitor applied to pin 4. Typically, a **440 pF** capacitor approximately leads to a 120-kHz operating frequency, meaning a 60-kHz clamp frequency for each branch. The oscillator frequency should be kept below 500 kHz (which corresponds to a pin4 capacitor in the range of **100 pF**).

As shown by Figure 16, two current sources  $I_{OSC(clamp)}$  (35  $\mu\text{A}$  typical) and  $I_{OSC(CH)}$  (105  $\mu\text{A}$  typical) charge the pin 4 capacitor until its voltage exceeds  $V_{OSC(high)}$  (5 V typically). At that moment, the output of the COMP\_OSC comparator (“ $SYNC$ ” of Figure 16) turns high and changes the COMP\_OSC reference threshold that drops from  $V_{OSC(high)}$  down to  $V_{OSC(low)}$  (hysteresis). The system enters a discharge phase where the  $I_{CH}$  current source is disabled and instead a sink current  $I_{OSC(DISCH)}$  (105  $\mu\text{A}$  typ.) discharges the pin 4 capacitor. This sequence lasts until  $V_{pin4}$  goes below  $V_{OSC(low)}$  when the “ $SYNC$ ” signal turns low and a new charging phase starts. A divider by two uses the “ $SYNC$ ” information to manage the phases of the interleaved PFC: the first  $SYNC$  pulse sets “phase 1”, the second one, “phase 2”, the third one phase 1 again... etc...

According to the selected phase, the “ $SYNC$ ” signal sets the relevant “Clock generator latch” that will generate the clock signal (“ $CLK1$ ” for phase 1, “ $CLK2$ ” for phase 2) when  $SYNC$  drops to zero (falling edge detector). So, the drivers are synchronized to  $SYNC$  falling edge.

Actually, the drivers cannot turn on at this very moment if the demagnetization of the coil is not yet complete (CrM operation). In this case, the clock signal is maintained high until the driver turns high (the clock generator latches are reset by the corresponding driver is high – reset on rising edge detector). Also, the discharge time can be prolonged if when  $V_{pin4}$  drops below  $V_{OSC(low)}$ , the driver of the phase cannot turn on because the core is not reset yet (CrM operation). In this case,  $V_{pin4}$  decreases until the driver turns high. The further discharge of  $V_{pin4}$  below  $V_{OSC(low)}$  helps maintain a substantial 180° phase shift in CrM that is in essence, guaranteed in DCM. In the two conditions (CrM or DCM), operation is stable and robust.

Figure 17 portrays the clock signal waveforms in different cases:

- In fixed frequency operation (DCM), the cycle time of the coil current is shorter than an oscillator period. Hence, as soon as the clock signal goes high, the driver can turn on and reset the clock generator latch. The clock signal is then a short pulse.

- However, the coil current can possibly be non zero when the clock signal turns high. The circuit would enter Continuous Conduction Mode (CCM) if the MOSFET turned on in that moment. In order to avoid CCM operation, the clock is prevented from setting the PWM latch until the core is reset (that is as low as “V<sub>ZCD</sub>” of Figure 8 is low). The clock signal remains high during this waiting phase (refer to Figure 12). Hence the next MOSFET conduction time occurs as soon as the coil

current has totally vanished. In other words, critical conduction mode (CrM) operation is obtained.

The clamp frequency can be computed using the following equation:

$$f_{osc} \cong \frac{60 \mu}{C_{OSC} + 10 p} \quad (\text{eq. 17})$$

where C<sub>OSC</sub> is the pin 4 external capacitor and C<sub>pin</sub> the pin 4 parasitic capacitance (about 10 pF).

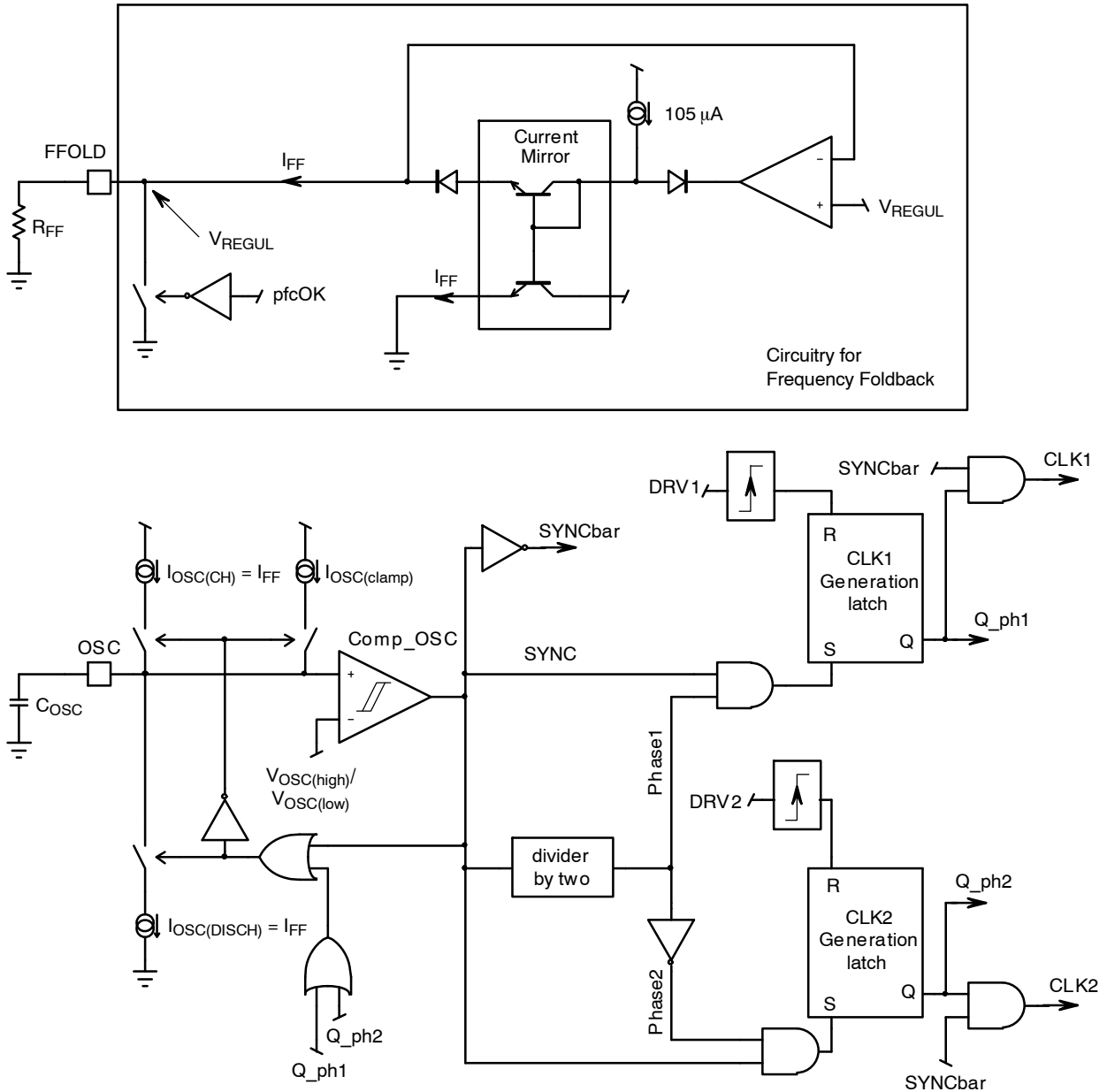

Figure 16. Oscillator Block

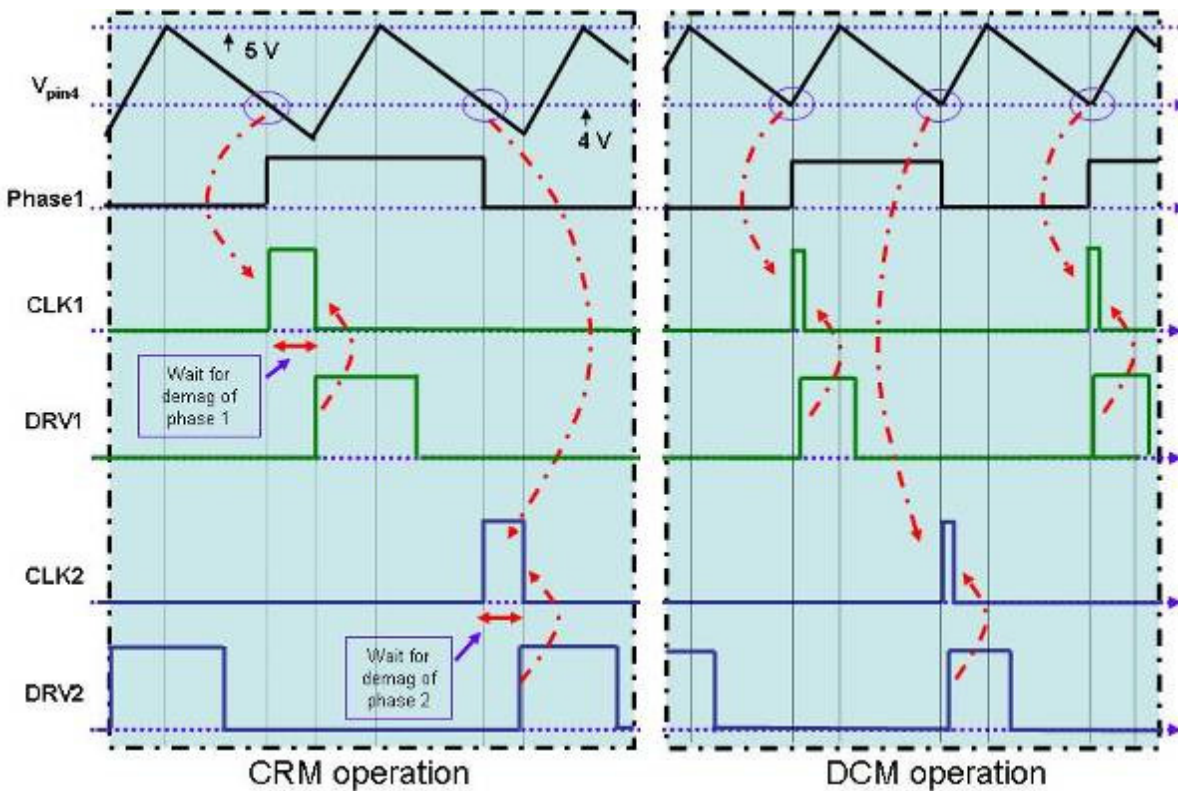

Figure 17. Typical Waveforms ( $T_{delay}$  not shown here for the sake of simplicity)

**Frequency Foldback**

In addition, the circuit features the frequency fold-back function to improve the light load efficiency. Practically, the oscillator charge and discharge currents ( $I_{OSC(CH)}$  and  $I_{OSC(DISCH)}$  of Figure 16) are not constant but dependent on the power level. More specifically,  $I_{OSC(CH)}$  and  $I_{OSC(DISCH)}$  linearly vary as a function of  $V_{control}$  output of the regulation block that thanks to the feed-forward featured by the NCP1631, is representative of the load.

The practical implementation is portrayed by Figure 16.

“ $V_{REGUL}$ ” is the signal derived from  $V_{control}$  that is effectively used to modulate the MOSFET on-time.  $V_{REGUL}$  is buffered and applied to pin 6 (“Frequency fold-back” pin). A resistor  $R_{FF}$  is to be connected to pin 6 to sink a current proportional to  $V_{REGUL}$

$$\left( I_{pin6} = I_{FF} = \frac{V_{REGUL}}{R_{FF}} \right).$$

This current is clamped not to exceed  $105 \mu A$  and copied by a current mirror to form  $I_{OSC(CH)}$  and  $I_{OSC(DISCH)}$ .

As a matter of fact, the oscillator charge current is:

$$\Rightarrow \begin{cases} I_{OSC(CH)} = I_{OSC(clamp)} + \frac{V_{REGUL}}{R_{FF}} & \text{if } \left( \frac{V_{REGUL}}{R_{FF}} \leq 105 \mu A \right) \\ I_{OSC(CH)} = I_{OSC(clamp)} + I_{OSC(CH)} = I_{OSC(CHT1)} = 140 \mu A & \text{otherwise} \end{cases} \quad (\text{eq. 18})$$

The oscillator charge current is then an increasing function of  $V_{REGUL}$  and is clamped to  $140 \mu A$ .

The oscillator discharge current is:

$$\Rightarrow \begin{cases} I_{OSC(DISCH)} = \frac{V_{REGUL}}{R_{FF}} & \text{if } \left( \frac{V_{REGUL}}{R_{FF}} \leq 105 \mu A \right) \\ I_{OSC(DISCH)} = I_{OSC(DISCH1)} = 105 \mu A & \text{otherwise} \end{cases} \quad (\text{eq. 19})$$

The oscillator discharge current is also an increasing function of  $V_{REGUL}$  and is clamped to  $105 \mu A$ .

As a consequence, the clamp frequency is also an increasing function of  $V_{REGUL}$  until it reaches a maximum

value for ( $I_{FF} = 105 \mu A$ ). If we consider the clamp frequency  $f_{OSC}$  computed by Equation 17 as the nominal value obtained at full load and if we name it “ $f_{OSC(nom)}$ ”:

$$\rightarrow \begin{cases} f_{OSC} = f_{OSC(nom)} & \text{if } (V_{REGUL} \geq R_{FF} \cdot 105 \mu A) \\ f_{OSC} = \frac{V_{REGUL}(R_{FF}I_{OSC(clamp)} + V_{REGUL})}{60 \mu R_{FF}(R_{FF}I_{OSC(clamp)} + 2V_{REGUL})} \cdot f_{OSC(nom)} & \text{if } (V_{REGUL} \leq R_{FF} \cdot 105 \mu A) \end{cases} \quad (\text{eq. 20})$$

Let's illustrate this operation on an example.

$V_{REGUL}$  is the control signal that varies between 0 and 1.66 V, ( $V_{REGUL} = 1.66$  V) corresponding to the maximum power ( $P_{in}HL$ ) that can virtually be delivered by the PFC stage as selected by the timing resistor (for more details, you can refer to the application note AND8407).

If one decides to start to reduce the clamp frequency when the power goes below ( $P_{in}HL/2$ ), the oscillator charge current should start to decrease when  $V_{REGUL}$  is 0.83 V.

Hence, the pin 6 resistor (" $R_{FF}$ ") must be selected so that pin 6 sources 105  $\mu A$  when  $V_{REGUL}$  equates 0.83 V:

$$R_{FF} = \frac{0.83 \text{ V}}{105 \mu A} = 7.9 \text{ k}\Omega \quad (\text{eq. 21})$$

Let's take ( $R_{FF} = 8.2 \text{ k}\Omega$ ) which is a normalized value. This selection leads to:

$$\rightarrow \begin{cases} f_{OSC} = f_{OSC(nom)} & \text{if } (V_{REGUL} \geq 8.2 \text{ k} \cdot 105 \mu = 860 \text{ mV}) \\ f_{OSC} = \frac{V_{REGUL}(R_{FF}I_{OSC(clamp)} + V_{REGUL})}{492 \text{ m}(R_{FF}I_{OSC(clamp)} + 2V_{REGUL})} \cdot f_{OSC(nom)} & \text{if } (V_{REGUL} \leq 860 \text{ mV}) \end{cases} \quad (\text{eq. 22})$$

For instance, if the nominal frequency ( $f_{OSC(nom)}$ ) is 120 kHz, the following characteristic is obtained.

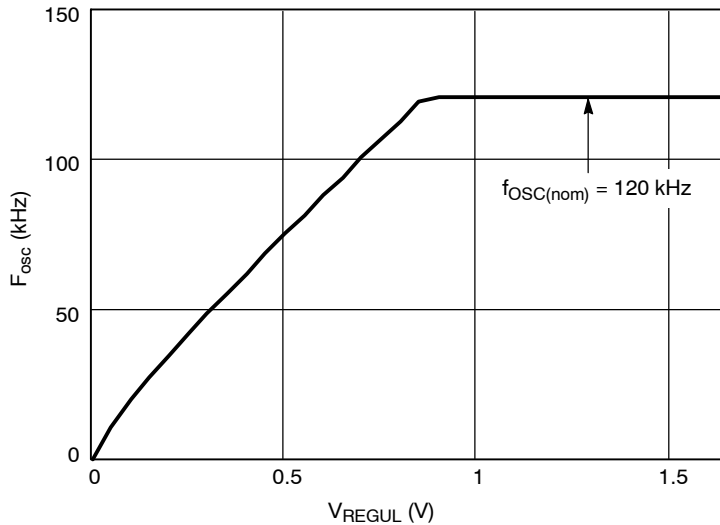

**Figure 18. Fold-back Characteristic of the Clamp Frequency with  $R_{FF} = 8.2 \text{ k}\Omega$  and  $f_{OSC(nom)} = 120 \text{ kHz}$**

If pin6 is grounded (accidentally or not), the circuit operates properly with a constant 140  $\mu A$  oscillator charge current and a 105  $\mu A$  discharge current. The clamp frequency equates its nominal value over the whole load range.

If pin6 is open, the oscillator charge current is equal to  $I_{OSC(clamp)}$  but the oscillator discharge current is null and hence the PFC stage cannot operate.

A minimum discharge current and hence a minimum clamp frequency can be forced by placing a resistor between pin 4 and ground. For instance, a 1.5-M $\Omega$  resistor forces a 3.3- $\mu A$  discharge current when the oscillator capacitor is fully charged and about 2.6  $\mu A$  when it is near the oscillator low threshold (4 V).

A transistor pulls the pin 6 down during startup to disable the frequency fold-back function.

**Skip Mode**

The circuit features the frequency fold-back that leads to a very efficient stand-by mode. In order to ensure a proper regulation in no load conditions even if this feature is not used (pin 6 grounded), the circuit skips cycles when the error amplifier output is at its minimum level. The error amplifier output is maintained between about 0.6 V and 3.6 V thanks to active clamps. A skip sequence occurs as long as the 0.6 V clamp circuitry is triggered and switching operation is recovered when the clamp is inactive.



- The 7- $\mu$ A current source is enabled that lowers the pin7 voltage for hysteresis purpose.

A short delay ( $T_{\text{delay}}$ ) is added to get sure that these three actions are properly done before the PFC driver is disabled and the “V<sub>control</sub>” and “pfcOK” pins are grounded.

At startup (and in UVLO situations that is when the V<sub>CC</sub> voltage is not sufficient for operation), a pnp transistor ensures that the BO pin voltage remains below the 1 V threshold until V<sub>CC</sub> reaches V<sub>CC(on)</sub>. This is to guarantee that the circuit starts operation in the right state, that is, “BONOK” high. When V<sub>CC</sub> exceeds V<sub>CC(on)</sub>, the pnp transistor turns off and the circuit enables the 7- $\mu$ A current source (I<sub>BO</sub>).

Also, (I<sub>BO</sub>) is enabled whenever the part is in off-mode, but at startup, I<sub>BO</sub> is disabled until V<sub>CC</sub> reaches V<sub>CC(on)</sub>.

### Brown-out Resistors Calculation

The BO resistors can be calculated with the following equations (for more details, refer to the application note AND8407)

$$R_{\text{bo1}} = \frac{(V_{\text{in,avg}})_{\text{boH}} - \left( (V_{\text{in,avg}})_{\text{boL}} \left[ 1 - \frac{f_{\text{line}}}{3f_{\text{line}}} \right] \right)}{I_{\text{HYST}}} \quad (\text{eq. 23})$$

$$R_{\text{bo2}} = \frac{R_{\text{bo1}}}{\left( \frac{(V_{\text{in,avg}})_{\text{boL}}}{V_{\text{BO(th)}}} \left( 1 - \frac{f_{\text{BO}}}{3f_{\text{line}}} \right) \right) - 1} \quad (\text{eq. 24})$$

### Feed-forward

As shown by Figure 19, The BO circuit also generates an internal current proportional to the input voltage average value (I<sub>Rt</sub>). The pin7 voltage is buffered and made available on pin 3. Placing a resistor between pin 3 and ground, enables to adjust a current proportional to the average input voltage. This current (I<sub>Rt</sub>) is internally copied and squared to form the charge current for the timing capacitor of each phase. Since this current is proportional to the square of the line magnitude, the conduction time is made inversely proportional to the line magnitude. This feed-forward feature makes the transfer function and the power delivery independent of the ac line level. Only the regulation output (V<sub>REGUL</sub>) controls the power amount. If the I<sub>Rt</sub> current is too low ( below 7  $\mu$ A), the controller goes in OFF mode to avoid damaging the MOSFETs with too long conduction time.

### Thermal Shutdown (TSD)

An internal thermal circuitry disables the circuit gate drive and then keeps the power switch off when the junction

temperature exceeds 140°C typically. The output stage is then enabled once the temperature drops below about 80°C (60°C hysteresis).

The temperature shutdown keeps active as long as the circuit is not reset, that is, as long as V<sub>CC</sub> keeps higher than V<sub>CCRESET</sub>. The reset action forces the TSD threshold to be the upper one (140°C). This ensures that any cold start-up will be done with the right TSD level.

### Under-Voltage Lockout Section

The NCP1631 incorporates an Under-Voltage Lockout block to prevent the circuit from operating when the power supply is not high enough to ensure a proper operation. An UVLO comparator monitors the pin 12 voltage (V<sub>CC</sub>) to allow the NCP1631 operation when V<sub>CC</sub> exceeds 12 V typically. The comparator incorporates some hysteresis (2.0 V typically) to prevent erratic operation as the V<sub>CC</sub> crosses the threshold. When V<sub>CC</sub> goes below the UVLO comparator lower threshold, the circuit turns off.

The circuit off state consumption is very low: < 50  $\mu$ A.

This low consumption enables to use resistors to charge the V<sub>CC</sub> capacitor during the start-up without the penalty of a too high dissipation.

### Output Drive Section

The circuit embeds two drivers to control the two interleaved branches. Each output stage contains a totem pole optimized to minimize the cross conduction current during high frequency operation. The gate drive is kept in a sinking mode whenever the Under-Voltage Lockout (UVLO) is active or more generally whenever the circuit is off. Its high current capability (-500 mA/+800 mA) allows it to effectively drive high gate charge power MOSFET.

### Reference Section

The circuit features an accurate internal reference voltage (V<sub>REF</sub>). V<sub>REF</sub> is optimized to be  $\pm 2.4\%$  accurate over the temperature range (the typical value is 2.5 V). V<sub>REF</sub> is the voltage reference used for the regulation and the over-voltage protection. The circuit also incorporates a precise current reference (I<sub>REF</sub>) that allows the Over-Current Limitation to feature a  $\pm 6\%$  accuracy over the temperature range.

### Fault Management and OFF Mode

The circuit detects a fault if the R<sub>t</sub> pin is open (Figure 20). Practically, if the pin sources less than 7  $\mu$ A, the “I<sub>Rt\_Low</sub>” signal sets a latch that turns off the circuit if its output (R<sub>t(open)</sub>) is high. A 30- $\mu$ s blanking time avoids parasitic fault detections. The latch is reset when the circuit is in UVLO state (too low V<sub>CC</sub> levels for proper operation).

## NCP1631

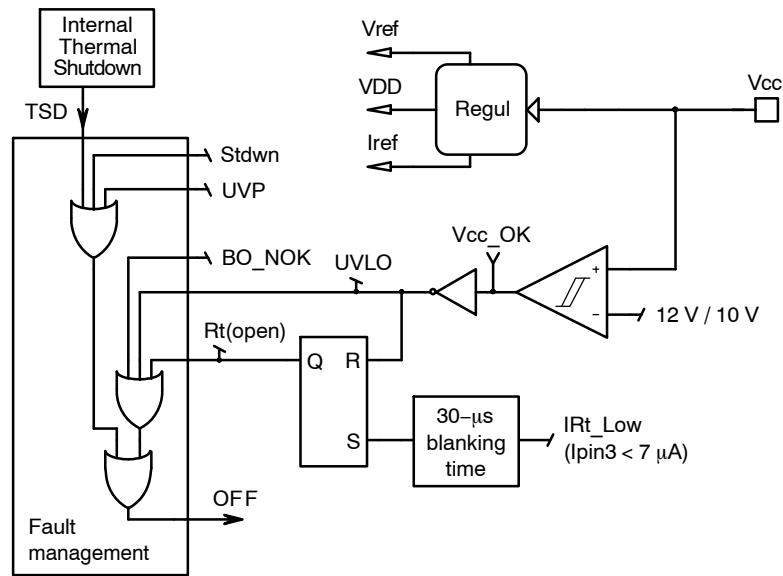

Figure 20. Fault Management Block

When any of the following faults is detected:

- brown-out (“BO\_NOK”)
- Under-Voltage Protection (“UVP”)
- Latch-off condition (“Stdwn”)
- Die over-temperature (“TSD”)
- Too low current sourced by the  $R_t$  pin (“ $R_{t(open)}$ ”)
- “UVLO” (improper  $V_{cc}$  level for operation)

The circuit turns off. In this mode, the controller stops operating. The major part of the circuit sleeps and its consumption is minimized ( $< 500 \mu A$ ). More specifically, when the circuit is in OFF state:

- The two drive outputs are kept low
- The  $7\text{-}\mu A$  current source of the brown-out block is enabled to set the proper start-up BO threshold if  $V_{cc}$  is high enough for proper operation. If not, the brown-out pin is pulled down by a pnp transistor for a proper input voltage sensing when the circuit recovers operation (see brown-out section).

- The pin5 capacitor ( $V_{control}$ ) is discharged and kept grounded along the OFF time, to initialize it for the next operating sequence, where it must be slowly and gradually charged to offer some soft-start.
- The “pfcOK” pin is grounded.
- The output of the “ $V_{TON}$  processing block” is grounded

When the circuit recovers after a fault, the first watchdog time is around  $20 \mu s$  instead of  $200 \mu s$  to allow a faster re-start.

In OFF mode at startup, the consumption is very low ( $< 50 \mu A$ ). The brown-out block is initialized not to allow operation (“BO\_NOK” high) by default. The PNP clamp is active and maintains the BO pin level below 1 V. The  $7\text{-}\mu A$  current source is enabled only when  $V_{CC}$  reaches  $V_{CC(on)}$  threshold.

# NCP1631

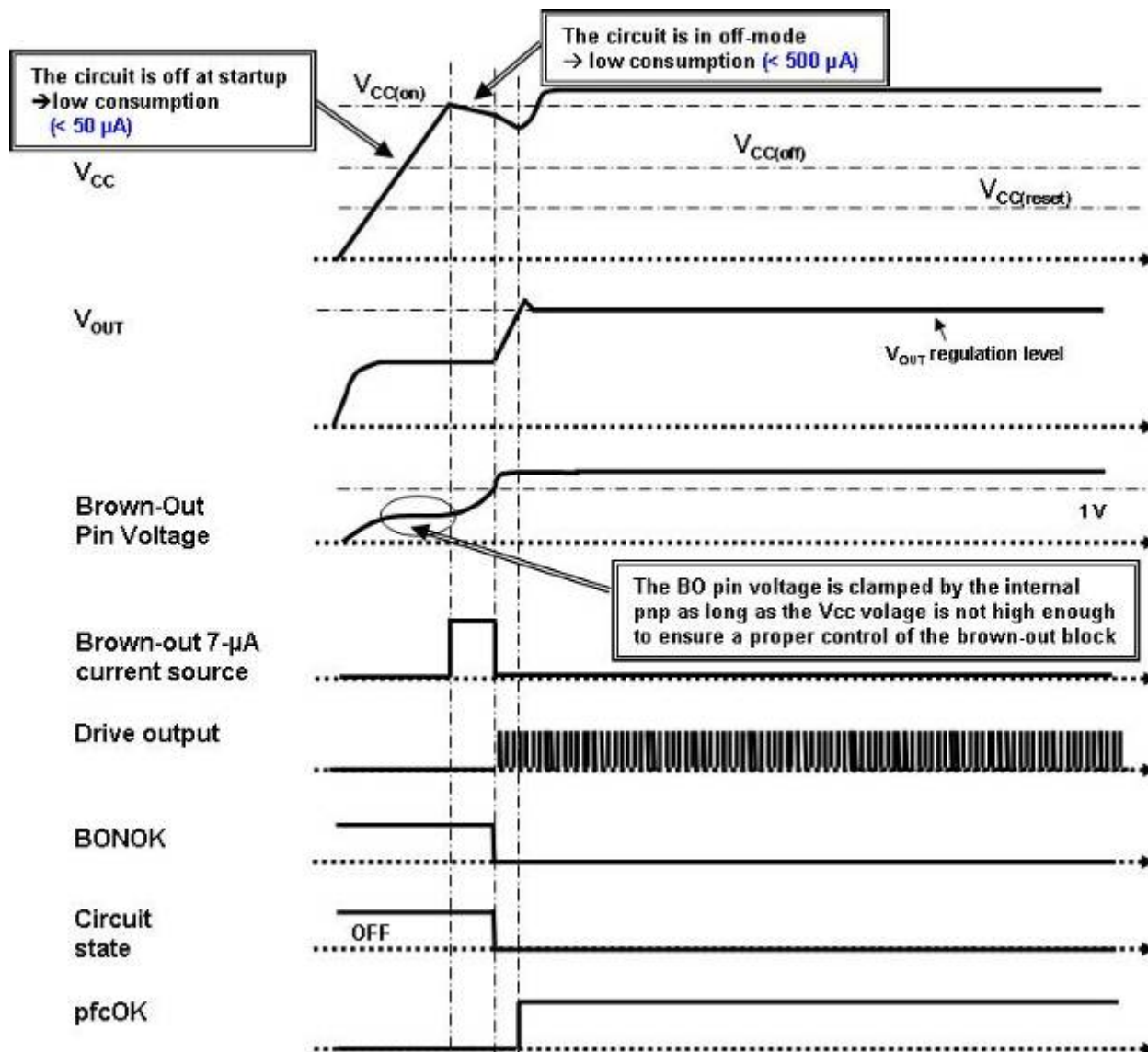
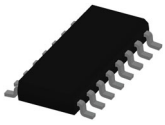

Figure 21. Start-up and Brown Out Conditions



**SOIC-16 9.90x3.90x1.37 1.27P**  
**CASE 751B**  
**ISSUE M**

DATE 18 OCT 2024

NOTES:

1. DIMENSIONING AND TOLERANCING PER ASME Y14.5M, 2018.
2. DIMENSION IN MILLIMETERS. ANGLE IN DEGREES.
3. DIMENSIONS D AND E1 DO NOT INCLUDE MOLD PROTRUSION.
4. MAXIMUM MOLD PROTRUSION 0.15mm PER SIDE.
5. DIMENSION b DOES NOT INCLUDE DAMBAR PROTRUSION. ALLOWABLE DAMBAR PROTRUSION SHALL BE 0.127mm TOTAL IN EXCESS OF THE b DIMENSION AT MAXIMUM MATERIAL CONDITION.

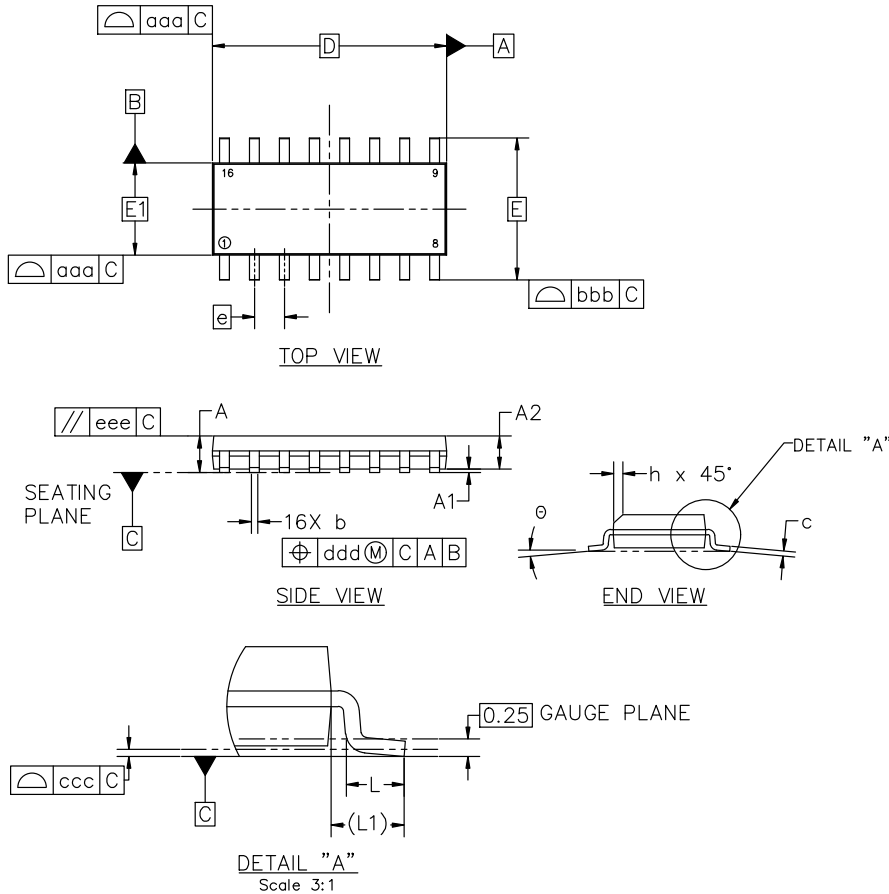

MILLIMETERS			
DIM	MIN	NOM	MAX
A	1.35	1.55	1.75
A1	0.10	0.18	0.25
A2	1.25	1.37	1.50
b	0.35	0.42	0.49
c	0.19	0.22	0.25
D	9.90 BSC		
E	6.00 BSC		
E1	3.90 BSC		
e	1.27 BSC		
h	0.25	---	0.50
L	0.40	0.83	1.25
L1	1.05 REF		
θ	0°	---	7°
TOLERANCE OF FORM AND POSITION			
aaa	0.10		
bbb	0.20		
ccc	0.10		
ddd	0.25		
eee	0.10		

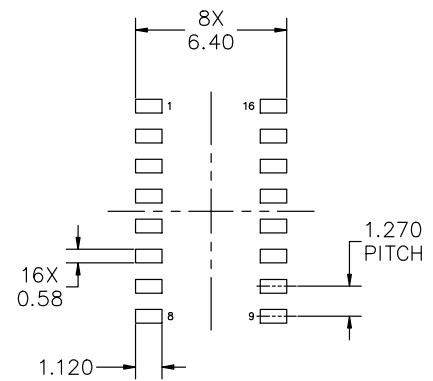

RECOMMENDED MOUNTING FOOTPRINT

\*FOR ADDITIONAL INFORMATION ON OUR PB-FREE STRATEGY AND SOLDERING DETAILS, PLEASE DOWNLOAD THE onsemi SOLDERING AND MOUNTING TECHNIQUES REFERENCE MANUAL, SOLDERRM/D

<b>DOCUMENT NUMBER:</b>	<b>98ASB42566B</b>	Electronic versions are uncontrolled except when accessed directly from the Document Repository. Printed versions are uncontrolled except when stamped "CONTROLLED COPY" in red.
<b>DESCRIPTION:</b>	<b>SOIC-16 9.90X3.90X1.37 1.27P</b>	<b>PAGE 1 OF 2</b>

onsemi and onSEMI are trademarks of Semiconductor Components Industries, LLC dba onsemi or its subsidiaries in the United States and/or other countries. onsemi reserves the right to make changes without further notice to any products herein. onsemi makes no warranty, representation or guarantee regarding the suitability of its products for any particular purpose, nor does onsemi assume any liability arising out of the application or use of any product or circuit, and specifically disclaims any and all liability, including without limitation special, consequential or incidental damages. onsemi does not convey any license under its patent rights nor the rights of others.

**SOIC-16 9.90x3.90x1.37 1.27P**  
**CASE 751B**  
**ISSUE M**

DATE 18 OCT 2024

**GENERIC  
MARKING DIAGRAM\***

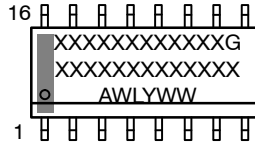

XXXXX = Specific Device Code  
A = Assembly Location  
WL = Wafer Lot  
Y = Year  
WW = Work Week  
G = Pb-Free Package

\*This information is generic. Please refer to device data sheet for actual part marking. Pb-Free indicator, "G" or microdot "•", may or may not be present. Some products may not follow the Generic Marking.

<p><b>STYLE 1:</b></p> <p>PIN 1. COLLECTOR  2. BASE  3. EMITTER  4. NO CONNECTION  5. EMITTER  6. BASE  7. COLLECTOR  8. COLLECTOR  9. BASE  10. EMITTER  11. NO CONNECTION  12. EMITTER  13. BASE  14. COLLECTOR  15. EMITTER  16. COLLECTOR</p>	<p><b>STYLE 2:</b></p> <p>PIN 1. CATHODE  2. ANODE  3. NO CONNECTION  4. CATHODE  5. CATHODE  6. NO CONNECTION  7. ANODE  8. CATHODE  9. CATHODE  10. ANODE  11. NO CONNECTION  12. CATHODE  13. CATHODE  14. NO CONNECTION  15. ANODE  16. CATHODE</p>	<p><b>STYLE 3:</b></p> <p>PIN 1. COLLECTOR, DYE #1  2. BASE, #1  3. EMITTER, #1  4. COLLECTOR, #1  5. COLLECTOR, #2  6. BASE, #2  7. EMITTER, #2  8. COLLECTOR, #2  9. COLLECTOR, #3  10. BASE, #3  11. EMITTER, #3  12. COLLECTOR, #3  13. COLLECTOR, #4  14. BASE, #4  15. EMITTER, #4  16. COLLECTOR, #4</p>	<p><b>STYLE 4:</b></p> <p>PIN 1. COLLECTOR, DYE #1  2. COLLECTOR, #1  3. COLLECTOR, #2  4. COLLECTOR, #2  5. COLLECTOR, #3  6. COLLECTOR, #3  7. COLLECTOR, #4  8. COLLECTOR, #4  9. BASE, #4  10. EMITTER, #4  11. BASE, #3  12. EMITTER, #3  13. BASE, #2  14. EMITTER, #2  15. BASE, #1  16. EMITTER, #1</p>
<p><b>STYLE 5:</b></p> <p>PIN 1. DRAIN, DYE #1  2. DRAIN, #1  3. DRAIN, #2  4. DRAIN, #2  5. DRAIN, #3  6. DRAIN, #3  7. DRAIN, #4  8. DRAIN, #4  9. GATE, #4  10. SOURCE, #4  11. GATE, #3  12. SOURCE, #3  13. GATE, #2  14. SOURCE, #2  15. GATE, #1  16. SOURCE, #1</p>	<p><b>STYLE 6:</b></p> <p>PIN 1. CATHODE  2. CATHODE  3. CATHODE  4. CATHODE  5. CATHODE  6. CATHODE  7. CATHODE  8. CATHODE  9. ANODE  10. ANODE  11. ANODE  12. ANODE  13. ANODE  14. ANODE  15. ANODE  16. ANODE</p>	<p><b>STYLE 7:</b></p> <p>PIN 1. SOURCE N-CH  2. COMMON DRAIN (OUTPUT)  3. COMMON DRAIN (OUTPUT)  4. GATE P-CH  5. COMMON DRAIN (OUTPUT)  6. COMMON DRAIN (OUTPUT)  7. COMMON DRAIN (OUTPUT)  8. SOURCE P-CH  9. SOURCE P-CH  10. COMMON DRAIN (OUTPUT)  11. COMMON DRAIN (OUTPUT)  12. COMMON DRAIN (OUTPUT)  13. GATE N-CH  14. COMMON DRAIN (OUTPUT)  15. COMMON DRAIN (OUTPUT)  16. SOURCE N-CH</p>	

<b>DOCUMENT NUMBER:</b>	<b>98ASB42566B</b>	Electronic versions are uncontrolled except when accessed directly from the Document Repository. Printed versions are uncontrolled except when stamped "CONTROLLED COPY" in red.
<b>DESCRIPTION:</b>	<b>SOIC-16 9.90X3.90X1.37 1.27P</b>	<b>PAGE 2 OF 2</b>

**onsemi** and **ONSEMI** are trademarks of Semiconductor Components Industries, LLC dba **onsemi** or its subsidiaries in the United States and/or other countries. **onsemi** reserves the right to make changes without further notice to any products herein. **onsemi** makes no warranty, representation or guarantee regarding the suitability of its products for any particular purpose, nor does **onsemi** assume any liability arising out of the application or use of any product or circuit, and specifically disclaims any and all liability, including without limitation special, consequential or incidental damages. **onsemi** does not convey any license under its patent rights nor the rights of others.

**onsemi**, **Onsemi**, and other names, marks, and brands are registered and/or common law trademarks of Semiconductor Components Industries, LLC dba "**onsemi**" or its affiliates and/or subsidiaries in the United States and/or other countries. **onsemi** owns the rights to a number of patents, trademarks, copyrights, trade secrets, and other intellectual property. A listing of **onsemi**'s product/patent coverage may be accessed at [www.onsemi.com/site/pdf/Patent-Marking.pdf](http://www.onsemi.com/site/pdf/Patent-Marking.pdf). **onsemi** reserves the right to make changes at any time to any products or information herein, without notice. The information herein is provided "as-is" and **onsemi** makes no warranty, representation or guarantee regarding the accuracy of the information, product features, availability, functionality, or suitability of its products for any particular purpose, nor does **onsemi** assume any liability arising out of the application or use of any product or circuit, and specifically disclaims any and all liability, including without limitation special, consequential or incidental damages. Buyer is responsible for its products and applications using **onsemi** products, including compliance with all laws, regulations and safety requirements or standards, regardless of any support or applications information provided by **onsemi**. "Typical" parameters which may be provided in **onsemi** data sheets and/or specifications can and do vary in different applications and actual performance may vary over time. All operating parameters, including "Typicals" must be validated for each customer application by customer's technical experts. **onsemi** does not convey any license under any of its intellectual property rights nor the rights of others. **onsemi** products are not designed, intended, or authorized for use as a critical component in life support systems or any FDA Class 3 medical devices or medical devices with a same or similar classification in a foreign jurisdiction or any devices intended for implantation in the human body. Should Buyer purchase or use **onsemi** products for any such unintended or unauthorized application, Buyer shall indemnify and hold **onsemi** and its officers, employees, subsidiaries, affiliates, and distributors harmless against all claims, costs, damages, and expenses, and reasonable attorney fees arising out of, directly or indirectly, any claim of personal injury or death associated with such unintended or unauthorized use, even if such claim alleges that **onsemi** was negligent regarding the design or manufacture of the part. **onsemi** is an Equal Opportunity/Affirmative Action Employer. This literature is subject to all applicable copyright laws and is not for resale in any manner.

## ADDITIONAL INFORMATION

### TECHNICAL PUBLICATIONS:

Technical Library: [www.onsemi.com/design/resources/technical-documentation](http://www.onsemi.com/design/resources/technical-documentation)  
onsemi Website: [www.onsemi.com](http://www.onsemi.com)

### ONLINE SUPPORT: [www.onsemi.com/support](http://www.onsemi.com/support)

For additional information, please contact your local Sales Representative at [www.onsemi.com/support/sales](http://www.onsemi.com/support/sales)