

# High Voltage High Efficiency Power Factor Correction Controller



## NCP1616

The NCP1616 is a high voltage PFC controller designed to drive PFC boost stages based on an innovative Current Controlled Frequency Foldback (CCFF) method. In this mode, the circuit operates in critical conduction mode (CrM) when the inductor current exceeds a programmable value. When the current is below this preset level, the NCP1616 linearly decays the frequency down to a minimum of about 26 kHz at the sinusoidal zero-crossing. CCFF maximizes the efficiency at both nominal and light load. In particular, the standby losses are reduced to a minimum. Innovative circuitry allows near-unity power factor even when the switching frequency is reduced.

The integrated high voltage start-up circuit eliminates the need for external start-up components and consumes negligible power during normal operation. Housed in a SOIC-9 package, the NCP1616 incorporates the features necessary for robust and compact PFC stages, with few external components.

### General Features

- High Voltage Start-Up Circuit with Integrated Brownout Detection
- Input to Force Controller into Standby Mode
- Skip Mode Near the Line Zero Crossing
- Fast Line / Load Transient Compensation
- Valley Switching for Improved Efficiency
- High Drive Capability: -500 mA/+800 mA
- Wide V<sub>CC</sub> Range: from 9.5 V to 30 V
- Input Voltage Range Detection
- Line Removal Detection Circuitry
- This is a Pb and Halogen Free Device

### Safety Features

- Soft Overvoltage Protection
- Overcurrent Protection
- Open Pin Protection for FB and STDBY/FAULT Pins
- Internal Thermal Shutdown
- Latch Input for OVP
- Bypass/Boost Diode Short Circuit Protection
- Open Ground Pin Protection

### Typical Applications

- PC Power Supplies
- Off Line Appliances Requiring Power Factor Correction
- LED Drivers
- Flat TVs

### MARKING DIAGRAM

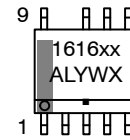

1616xx = Specific Device Code  
 xx = A1 or A2  
 A = Assembly Location  
 L = Wafer Lot  
 Y = Year  
 W = Work Week  
 ■ = Pb-Free Package

### PIN CONNECTIONS

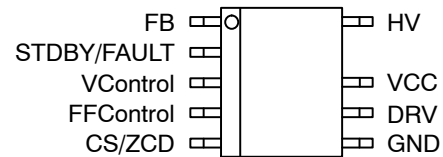

NCP1616 9 Pins (Top View)

### ORDERING INFORMATION

See detailed ordering and shipping information on page 4 of this data sheet.

# NCP1616

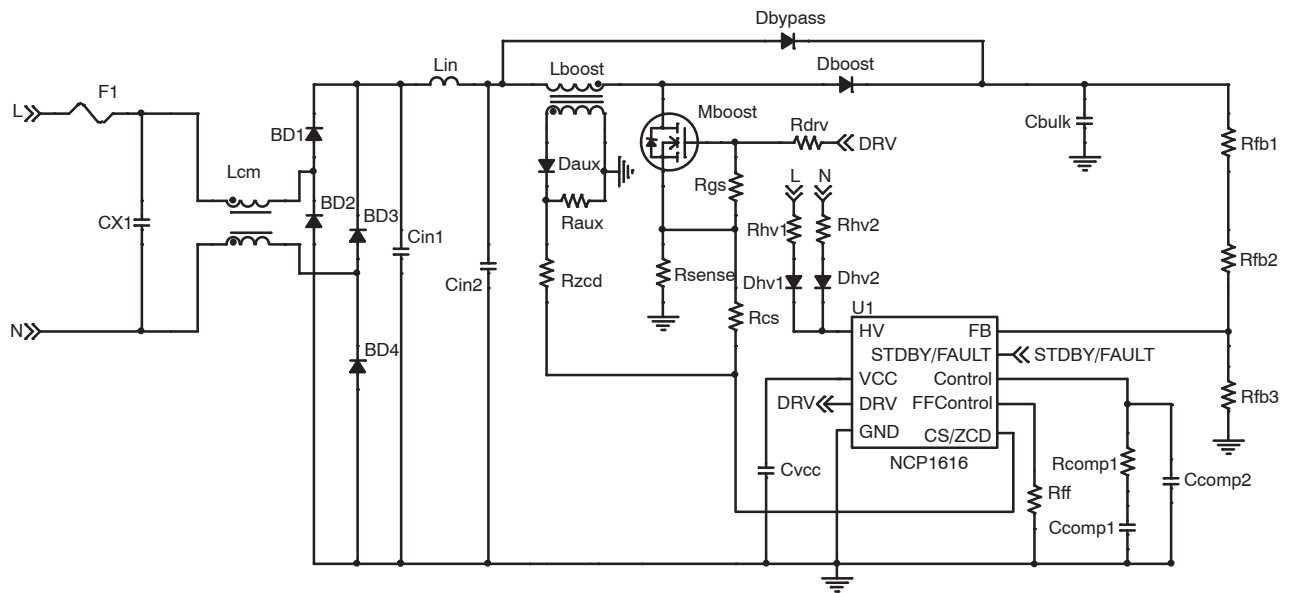

Figure 1. Typical Application Circuit

# NCP1616

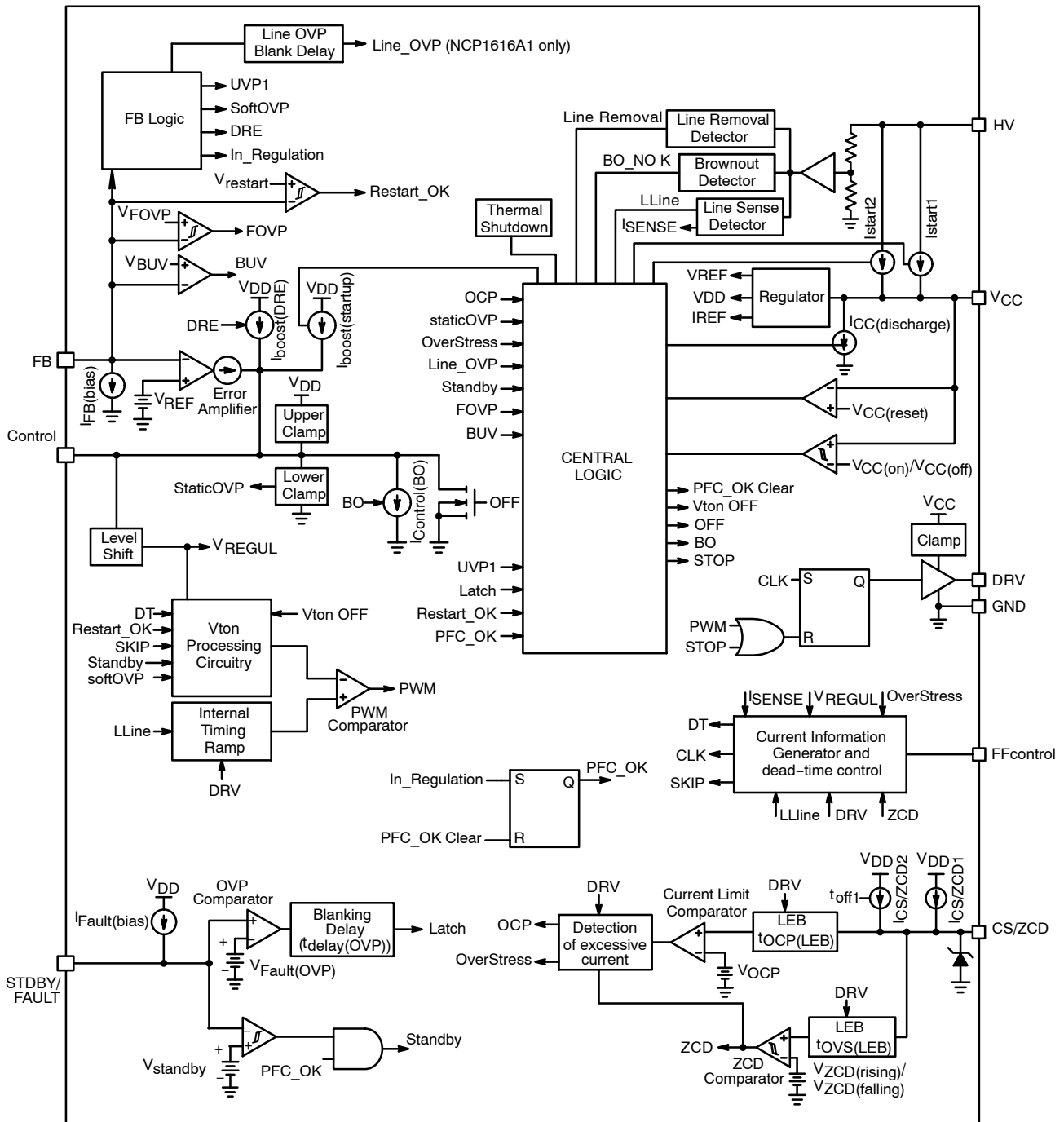

Figure 2. Functional Block Diagram

# NCP1616

**Table 1. PIN FUNCTION DESCRIPTION**

Pin Number	Name	Function
1	FB	<p>This pin receives a portion of the PFC output voltage for the regulation and the dynamic response enhancer (DRE) that speeds up the loop response when the output voltage drops below 95.5% of the regulation level. <math>V_{FB}</math> is also the input signal for the Soft-Overvoltage Comparators as well as the Undervoltage (UVP) Comparator. The UVP Comparator prevents operation as long as <math>V_{FB}</math> is lower than 12% of the reference voltage (<math>V_{REF}</math>). The Soft-Overvoltage Comparator (Soft-OVP) gradually reduces the duty ratio to zero when <math>V_{FB}</math> exceeds 105% of <math>V_{REF}</math>. A 250 nA sink current is built-in to trigger the UVP protection and disable the part if the feedback pin is accidentally open. A dedicated comparator monitors the bulk voltage and disables the controller if a line overvoltage fault is detected. The Fast Overvoltage (Fast-OVP) and Bulk Undervoltage (BUV) comparators monitor the FB pin voltage. The circuit disables the driver if the VFB exceeds the VFOVP threshold which is set 2% higher than the reference for the Soft-OVP comparator.</p> <p>The BUV Comparator trips when VFB falls below VBUV. A BUV fault disables the driver and grounds the PFCOK latch. The BUV function has no action whenever the PFCOK latch is in low state. Once the downstream converter is enabled the BUV Comparator monitors the output voltage to ensure it is high enough for proper operation of the downstream converter.</p>
2	STDBY/ FAULT	This pin is used to force the controller into standby mode. The controller enters fault mode if the voltage of this pin is pulled above the fault threshold. Fault detection triggers a latch.
3	Control	The error amplifier output is available on this pin. The network connected between this pin and ground sets the regulation loop bandwidth. It is typically set below 20 Hz to achieve high power factor ratios. This pin is grounded when the controller is disabled. The voltage on this pin gradually increases during power up to achieve a soft-start.
4	FFcontrol	<p>This pin sources a current representative to the line current. Connect a resistor between this pin and GND to generate a voltage representative of the line current. When this voltage exceeds the internal 2.5 V reference, the circuit operates in critical conduction mode. If the pin voltage is below 2.5 V, a dead-time is generated. By this means, the circuit increases the deadtime when the current is smaller and decreases the deadtime as the current increases.</p> <p>The circuit skips cycles whenever <math>V_{FFcontrol}</math> is below 0.65 V to prevent the PFC stage from operating near the line zero crossing where the power transfer is particularly inefficient. This does result in a slightly increased distortion of the current. If superior power factor is required, offset the voltage on this pin by more than 0.75 V to inhibit skip operation.</p>
5	CS/ZCD	This pin monitors the MOSFET current to limit its maximum current. This pin is also connected to an internal comparator for zero current detection (ZCD). This comparator is designed to monitor a signal from an auxiliary winding and to detect the core reset when this voltage drops to zero. The auxiliary winding voltage is to be applied through a diode to avoid altering the current sense information for the on time (see application schematic).
6	GND	Ground reference.
7	DRV	MOSFET driver. The high current capability of the totem pole gate drive (-0.5/ +0.8 A) makes it suitable to effectively drive high gate charge power MOSFETs.
8	VCC	Supply input. This pin is the positive supply of the IC. The circuit starts to operate when $V_{CC}$ exceeds $V_{CC(on)}$ . After start-up, the operating range is 9.5 V up to 30 V.
9	HV	This pin is the input for the line removal detection, line level detection, and brownout detection circuits. This pin is also the input for the high voltage start-up circuit.

**Table 2. ORDERABLE PART OPTION**

Part Number	Restart Threshold	$I_{dt1}$	Brownout	Max Dead-Time	High Line Threshold	Line OVP
NCP1616A1DR2G	2.35 V	125.5 $\mu$ A	100 Vdc	29 $\mu$ s	236 Vdc	Enabled
NCP1616A2DR2G	2.35 V	125.5 $\mu$ A	100 Vdc	29 $\mu$ s	236 Vdc	Disabled

**Table 3. ORDERING INFORMATION**

Part Number	Device Marking	Package	Shipping†
NCP1616A1DR2G	1616A1	SOIC-10 NB, LESS PIN 9 (Pb-Free)	2500 / Tape & Reel
NCP1616A2DR2G	1616A2	SOIC-10 NB, LESS PIN 9 (Pb-Free)	2500 / Tape & Reel

†For information on tape and reel specifications, including part orientation and tape sizes, please refer to our Tape and Reel Packaging Specifications Brochure, BRD8011/D.

# NCP1616

**Table 4. MAXIMUM RATINGS** (Notes 1 and 2)

Rating	Pin	Symbol	Value	Unit
High Voltage Start-Up Circuit Input Voltage	HV	$V_{HV}$	-0.3 to 700	V
Zero Current Detection and Current Sense Input Voltage (Note 3)	CS/ZCD	$V_{CS/ZCD}$	-0.3 to $V_{CS/ZCD(MAX)}$	V
Zero Current Detection and Current Sense Input Current	CS/ZCD	$I_{CS/ZCD}$	+5	mA
Control Input Voltage (Note 4)	Control	$V_{Control}$	-0.3 to $V_{Control(MAX)}$	V
Supply Input Voltage	VCC	$V_{CC(MAX)}$	-0.3 to 30	V
Driver Maximum Voltage (Note 5)	DRV	$V_{DRV}$	-0.3 to $V_{DRV}$	V
Driver Maximum Current	DRV	$I_{DRV(SRC)}$ $I_{DRV(SNK)}$	500 800	mA
Maximum Input Voltage (Note 6)	Other Pins	$V_{MAX}$	-0.3 to 7	V
Maximum Operating Junction Temperature		$T_J$	-40 to 150	°C
Storage Temperature Range		$T_{STG}$	-60 to 150	°C
Lead Temperature (Soldering, 10 s)		$T_{L(MAX)}$	300	°C
Moisture Sensitivity Level		MSL	1	-
Power Dissipation ( $T_A = 70^\circ\text{C}$ , 1 Oz Cu, 0.155 Sq Inch Printed Circuit Copper Clad) Plastic Package SOIC-9NB		$P_D$	380	mW
Thermal Resistance, (Junction to Ambient 1 Oz Cu Printed Circuit Copper Clad) Plastic Package SOIC-9NB		$R_{\theta JA}$	210	°C/W
ESD Capability Human Body Model per JEDEC Standard JESD22-A114E. Charge Device Model per JEDEC Standard JESD22-C101E.			> 2000 > 1000	V

Stresses exceeding those listed in the Maximum Ratings table may damage the device. If any of these limits are exceeded, device functionality should not be assumed, damage may occur and reliability may be affected.

1. This device contains Latch-Up protection and exceeds  $\pm 100$  mA per JEDEC Standard JESD78.
2. Low Conductivity Board. As mounted on 80 x 100 x 1.5 mm FR4 substrate with a single layer of 50 mm<sup>2</sup> of 2 oz copper traces and heat spreading area. As specified for a JEDEC51-1 conductivity test PCB. Test conditions were under natural convection of zero air flow.
3.  $V_{CS/ZCD(MAX)}$  is the CS/ZCD pin positive clamp voltage.
4.  $V_{Control(MAX)}$  is the Control pin positive clamp voltage.
5. When  $V_{CC}$  exceeds the driver clamp voltage ( $V_{DRV(high)}$ ),  $V_{DRV}$  is equal to  $V_{DRV(high)}$ . Otherwise,  $V_{DRV}$  is equal to  $V_{CC}$ .
6. When the voltage applied to these pins exceeds 5.5 V, they sink a current about equal to  $(V_{pin} - 5.5 \text{ V}) / (4 \text{ k}\Omega)$ . An applied voltage of 7 V generates a sink current of approximately 0.375 mA.

# NCP1616

**Table 5. ELECTRICAL CHARACTERISTICS** ( $V_{CC} = 15\text{ V}$ ,  $V_{HV} = 120\text{ V}$ ,  $V_{FB} = 2.4\text{ V}$ ,  $C_{VControl} = 10\text{ nF}$ ,  $V_{FFcontrol} = 2.6\text{ V}$ ,  $V_{ZCD/CS} = 0\text{ V}$ ,  $V_{STDBY/FAULT} = 1\text{ V}$ ,  $C_{DRV} = 1\text{ nF}$ , for typical values  $T_J = 25^\circ\text{C}$ , for min/max values,  $T_J$  is  $-40^\circ\text{C}$  to  $125^\circ\text{C}$ , unless otherwise noted)

Characteristics	Conditions	Symbol	Min	Typ	Max	Unit
<b>START-UP AND SUPPLY CIRCUITS</b>						
Start-Up Threshold	$V_{CC}$ increasing	$V_{CC(on)}$	16	17	18	V
Minimum Operating Voltage	$V_{CC}$ decreasing	$V_{CC(off)}$	8.5	9.0	9.5	V
$V_{CC}$ Hysteresis	$V_{CC(on)} - V_{CC(off)}$	$V_{CC(HYS)}$	7.0	8.0	–	V
Internal Latch / Logic Reset Level	$V_{CC}$ decreasing	$V_{CC(reset)}$	7.3	7.8	8.3	V
Difference Between $V_{CC(off)}$ and $V_{CC(reset)}$	$V_{CC(off)} - V_{CC(reset)}$	$\Delta V_{CC(reset)}$	0.5	–	–	V
Transition from $I_{start1}$ to $I_{start2}$	$V_{CC}$ increasing, $I_{HV} = 650\text{ }\mu\text{A}$	$V_{CC(inhibit)}$	–	0.8	–	V
Start-Up Time	$C_{VCC} = 0.47\text{ }\mu\text{F}$ , $V_{CC} = 0\text{ V}$ to $V_{CC(on)}$	$t_{start-up}$	–	–	2.5	ms
Inhibit Current Sourced from $V_{CC}$ Pin	$V_{CC} = 0\text{ V}$ , $V_{HV} = 100\text{ V}$	$I_{start1}$	0.375	0.5	0.87	mA
Start-Up Current Sourced from $V_{CC}$ Pin	$V_{CC} = V_{CC(on)} - 0.5\text{ V}$ , $V_{HV} = 100\text{ V}$	$I_{start2}$	6.5	12	16.5	mA
Start-Up Circuit Off-State Leakage Current	$V_{HV} = 400\text{ V}$ $V_{HV} = 700\text{ V}$	$I_{HV(off1)}$	–	–	70	$\mu\text{A}$
		$I_{HV(off2)}$	–	–	75	$\mu\text{A}$
Minimum Voltage for Start-Up Circuit Start-Up	$I_{start2} = 6.5\text{ mA}$ , $V_{CC} = V_{CC(on)} - 0.5\text{ V}$	$V_{HV(MIN)}$	–	–	38	V
Supply Current Standby Mode No Switching Operating Current	$V_{standby} = 0\text{ V}$ , $V_{Restart} = 3\text{ V}$ $V_{FB} = 2.55\text{ V}$ $f = 50\text{ kHz}$ , $C_{DRV} = \text{open}$ , $V_{Control} = 2.5\text{ V}$ , $V_{FB} = 2.45\text{ V}$	$I_{CC3}$	–	–	1.0	mA
		$I_{CC4}$	–	–	2.8	
		$I_{CC5}$	–	2.0	3.5	

## LINE REMOVAL

Line Voltage Removal Detection Timer		$t_{line(removal)}$	60	100	165	ms
Upslope Detection Reset Timer	HV increasing	$t_{HV(up)}$	–	14	–	ms
Downslope Detection Reset Timer	HV decreasing	$t_{HV(down)}$	–	1	–	ms
Slope Detection Limit		$S_{HV}$	–	3.5	–	V/ms
$V_{CC}$ Discharge Current	$V_{CC} = V_{CC(off)} + 200\text{ mV}$ $V_{CC} = V_{CC(discharge)} + 200\text{ mV}$	$I_{CC(discharge)}$	20	25	30	mA
			10	16.5	30	
HV Discharge Current		$I_{HV(discharge)}$	–	4	–	mA
HV Discharge Level		$V_{HV(discharge)}$	–	–	40	V
$V_{CC}$ Discharge Level		$V_{CC(discharge)}$	3.8	4.5	5.4	V

## LINE DETECTION

High Line Level Detection Threshold	$V_{HV}$ increasing	$V_{lineselect(HL)}$	220	236	252	V
Low Line Level Detection Threshold	$V_{HV}$ decreasing	$V_{lineselect(LL)}$	207	222	237	V
Line Select Hysteresis	$V_{HV}$ increasing	$V_{lineselect(HYS)}$	10	–	–	V
High to Low Line Mode Selector Timer	$V_{HV}$ decreasing	$t_{line}$	21	26	31	ms
Low to High Line Mode Selector Timer	$V_{HV}$ increasing	$t_{delay(line)}$	200	300	400	$\mu\text{s}$
Line Level Lockout Timer	After $t_{line}$ expires	$t_{line(lockout)}$	120	150	180	ms

## ON-TIME CONTROL

Maximum On Time – Low Line	$V_{HV} = 162.5\text{ V}$ , $V_{Control} = V_{Control(MAX)}$ $V_{HV} = 162.5\text{ V}$ , $V_{Control} = 2.5\text{ V}$	$t_{on(LL)}$	20.5	23.8	27.5	$\mu\text{s}$
		$t_{on(LL)2}$	9.5	11.2	13.0	
Maximum On Time – High Line	$V_{HV} = 325\text{ V}$ , $V_{Control} = V_{Control(MAX)}$	$t_{on(HL)}$	6.8	8.1	9.2	$\mu\text{s}$

# NCP1616

**Table 5. ELECTRICAL CHARACTERISTICS** ( $V_{CC} = 15\text{ V}$ ,  $V_{HV} = 120\text{ V}$ ,  $V_{FB} = 2.4\text{ V}$ ,  $C_{VControl} = 10\text{ nF}$ ,  $V_{FFcontrol} = 2.6\text{ V}$ ,  $V_{ZCD/CS} = 0\text{ V}$ ,  $V_{STDBY/FAULT} = 1\text{ V}$ ,  $C_{DRV} = 1\text{ nF}$ , for typical values  $T_J = 25^\circ\text{C}$ , for min/max values,  $T_J$  is  $-40^\circ\text{C}$  to  $125^\circ\text{C}$ , unless otherwise noted)

Characteristics	Conditions	Symbol	Min	Typ	Max	Unit
<b>ON-TIME CONTROL</b>						
Minimum On-Time	$V_{HV} = 162\text{ V}$ $V_{HV} = 325\text{ V}$	$t_{onLL(MIN)}$ $t_{onHL(MIN)}$	– –	– –	200 100	ns
<b>CURRENT SENSE</b>						
Current Limit Threshold		$V_{ILIM}$	0.46	0.50	0.54	V
Leading Edge Blanking Duration		$t_{OCP(LEB)}$	100	200	350	ns
Current Limit Propagation Delay	Step $V_{CS/ZCD} > V_{ILIM}$ to DRV falling edge	$t_{OCP(delay)}$	–	40	200	ns
Overstress Leading Edge Blanking Duration		$t_{OVS(LEB)}$	50	100	170	ns
Over Stress Detection Propagation Delay	$V_{CS/ZCD} > V_{ZCD(rising)}$ to DRV falling edge	$t_{OVS(delay)}$	–	40	200	ns
<b>REGULATION BLOCK</b>						
Reference Voltage	$T_J = 25^\circ\text{C}$ $T_J = -40$ to $125^\circ\text{C}$	$V_{REF}$ $V_{REF}$	2.475 2.445	2.500 2.500	2.525 2.550	V
Error Amplifier Current	Source Sink $V_{FB} = 2.4\text{ V}$ , $V_{VControl} = 2\text{ V}$ $V_{FB} = 2.6\text{ V}$ , $V_{VControl} = 2\text{ V}$	$I_{EA(SRC)}$ $I_{EA(SNK)}$	16 16	20 20	24 24	$\mu\text{A}$
Open Loop Error Amplifier Transconductance	$V_{FB} = V_{REF} \pm 100\text{ mV}$	$g_m$	180	210	245	$\mu\text{S}$
Maximum Control Voltage	$V_{FB} = 2\text{ V}$	$V_{Control(MAX)}$	–	4.5	–	V
Minimum Control Voltage	$V_{FB} = 2.6\text{ V}$	$V_{Control(MIN)}$	–	0.5	–	V
EA Output Control Voltage Range	$V_{Control(MAX)} - V_{Control(MIN)}$	$\Delta V_{Control}$	3.85	4.0	4.1	V
DRE Detect Threshold	$V_{FB}$ decreasing	$V_{DRE}$	–	2.388	–	V
DRE Threshold Hysteresis	$V_{FB}$ increasing	$V_{DRE(HYS)}$	–	–	25	mV
Ratio between the DRE Detect Threshold and the Regulation Level	$V_{FB}$ decreasing, $V_{DRE} / V_{REF}$	$K_{DRE}$	95.0	95.5	96.0	%
Control Pin Source Current During Start-Up	$V_{VControl} = 2\text{ V}$	$I_{Control(start-up)}$	80	100	113	$\mu\text{A}$
EA Boost Current During Start-Up		$I_{boost(start-up)}$	–	80	–	$\mu\text{A}$
Control Pin Source Current During DRE	$V_{VControl} = 2\text{ V}$	$I_{Control(DRE)}$	180	220	250	$\mu\text{A}$
EA Boost Current During DRE		$I_{boost(DRE)}$	–	200	–	$\mu\text{A}$
<b>PFC GATE DRIVE</b>						
Rise Time (10–90%)	$V_{DRV}$ from 10 to 90% of $V_{DRV}$	$t_{DRV(rise)}$	–	40	80	ns
Fall Time (90–10%)	90 to 10% of $V_{DRV}$	$t_{DRV(fall)}$	–	20	60	ns
Source Current Capability	$V_{DRV} = 0\text{ V}$	$I_{DRV(SRC)}$	–	500	–	mA
Sink Current Capability	$V_{DRV} = 12\text{ V}$	$I_{DRV(SNK)}$	–	800	–	mA
High State Voltage	$V_{CC} = V_{CC(off)} + 0.2\text{ V}$ , $R_{DRV} = 10\text{ k}\Omega$ $V_{CC} = 28\text{ V}$ , $R_{DRV} = 10\text{ k}\Omega$	$V_{DRV(high1)}$ $V_{DRV(high2)}$	8 10	– 12	– 14	V
Low Stage Voltage	$V_{STDBY} = 0\text{ V}$	$V_{DRV(low)}$	–	–	0.25	V
<b>ZERO CURRENT DETECTION</b>						
Zero Current Detection Threshold	$V_{CS/ZCD}$ rising $V_{CS/ZCD}$ falling	$V_{ZCD(rising)}$ $V_{ZCD(falling)}$	675 200	750 250	825 300	mV
ZCD and Current Sense Ratio	$V_{ZCD(rising)}/V_{ILIM}$	$K_{ZCD/ILIM}$	1.4	1.5	1.6	–

# NCP1616

**Table 5. ELECTRICAL CHARACTERISTICS** ( $V_{CC} = 15\text{ V}$ ,  $V_{HV} = 120\text{ V}$ ,  $V_{FB} = 2.4\text{ V}$ ,  $C_{VControl} = 10\text{ nF}$ ,  $V_{FFcontrol} = 2.6\text{ V}$ ,  $V_{ZCD/CS} = 0\text{ V}$ ,  $V_{STDBY/FAULT} = 1\text{ V}$ ,  $C_{DRV} = 1\text{ nF}$ , for typical values  $T_J = 25^\circ\text{C}$ , for min/max values,  $T_J$  is  $-40^\circ\text{C}$  to  $125^\circ\text{C}$ , unless otherwise noted)

Characteristics	Conditions	Symbol	Min	Typ	Max	Unit
<b>ZERO CURRENT DETECTION</b>						
Positive Clamp Voltage	$I_{CS/ZCD} = 0.75\text{ mA}$ $I_{CS/ZCD} = 5\text{ mA}$	$V_{CS/ZCD(MAX1)}$ $V_{CS/ZCD(MAX2)}$	7.1 15.4	7.4 15.8	7.8 16.1	V
CS/ZCD Input Bias Current	$V_{CS/ZCD} = V_{ZCD(rising)}$ $V_{CS/ZCD} = V_{ZCD(falling)}$	$I_{CS/ZCD(bias1)}$ $I_{CS/ZCD(bias2)}$	0.5 0.5	– –	2.0 2.0	$\mu\text{A}$
ZCD Propagation Delay	Measured from $V_{CS/ZCD} = V_{ZCD(falling)}$ to DRV rising	$t_{ZCD}$	–	60	200	ns
Minimum detectable ZCD Pulse Width	Measured from $V_{ZCD(rising)}$ to $V_{ZCD(falling)}$	$t_{SYNC}$	–	110	200	ns
Maximum Off-Time (Watchdog Timer)	$V_{CS/ZCD} > V_{ZCD(rising)}$	$t_{off1}$ $t_{off2}$	80 700	200 1000	320 1300	$\mu\text{s}$
Missing Valley Timeout Timer	Measured after last ZCD transition	$t_{out}$	20	30	50	$\mu\text{s}$
Pull-Up Current Source	Detects open pin fault.	$I_{CS/ZCD1}$	–	1	–	$\mu\text{A}$
Source Current for CS/ZCD Impedance Testing	Pulls up at the end of $t_{off1}$	$I_{CS/ZCD2}$	–	250	–	$\mu\text{A}$
<b>CURRENT CONTROLLED FREQUENCY FOLDBACK</b>						
Minimum Dead Time	$V_{FFControl} = 2.6\text{ V}$	$t_{DT1}$	–	–	0	$\mu\text{s}$
Median Dead Time	$V_{FFControl} = 1.75\text{ V}$	$t_{DT2}$	11	14	18	$\mu\text{s}$
Maximum Dead Time	$V_{FFControl} = 1.0\text{ V}$	$t_{DT3}$	22	29	34	$\mu\text{s}$
FFcontrol Pin Current – Low Line	$V_{HV} = 162.5\text{ V}$ , $V_{Control} = V_{Control(MAX)}$	$I_{DT1}$	111	125.5	140	$\mu\text{A}$
FFcontrol Pin Current – High Line	$V_{HV} = 325\text{ V}$ , $V_{Control} = V_{Control(MAX)}$	$I_{DT2}$	116	135	154	$\mu\text{A}$
FFcontrol Skip Level	$V_{FFControl} = \text{increasing}$ $V_{FFControl} = \text{decreasing}$	$V_{skip(out)}$ $V_{skip(in)}$	– 0.55	0.75 0.65	0.85 –	V
FFcontrol Skip Hysteresis		$V_{SKIP(HYS)}$	50	–	–	mV
Minimum Operating Frequency		$f_{MIN}$	–	26	–	kHz
<b>FEEDBACK OVER AND UNDERVOLTAGE PROTECTION</b>						
Soft-OVP to $V_{REF}$ Ratio	$V_{FB} = \text{increasing}$ , $V_{SOVP}/V_{REF}$	$K_{SOVP/VREF}$	104	105	106	%
Soft-OVP Threshold	$V_{FB} = \text{increasing}$	$V_{SOVP}$	–	2.625	–	V
Soft-OVP Hysteresis	$V_{FB} = \text{decreasing}$	$V_{SOVP(HYS)}$	35	50	65	mV
Static OVP Minimum Duty Ratio	$V_{FB} = 2.55\text{ V}$ , $V_{Control} = \text{open}$	$D_{MIN}$	–	–	0	%
Undervoltage to $V_{REF}$ Ratio	$V_{FB} = \text{decreasing}$ , $V_{UVP1}/V_{REF}$	$K_{UVP1/VREF}$	8	12	16	%
Undervoltage Threshold	$V_{FB} = \text{decreasing}$	$V_{UVP1}$	–	300	–	mV
Undervoltage to $V_{REF}$ Hysteresis Ratio	$V_{FB} = \text{increasing}$	$V_{UVP1(HYS)}$	–	11	25	mV
Feedback Input Sink Current	$V_{FB} = V_{SOVP}$ $V_{FB} = V_{UVP1}$	$I_{FB(SNK1)}$ $I_{FB(SNK2)}$	50 50	200 200	450 450	nA
<b>FAST OVERVOLTAGE AND BULK UNDERVOLTAGE PROTECTION ON FB PIN</b>						
Fast OVP Threshold	$V_{FB} \text{ increasing}$	$V_{FOVP}$	–	2.675	–	V
Fast OVP Hysteresis	$V_{FB} \text{ decreasing}$	$V_{FOVP(HYS)}$	50	100	150	mV
Ratio Between Fast and Soft OVP Levels	$K_{FOVP/SOVP} = V_{FOVP}/V_{SOVP}$	$K_{FOVP/SOVP}$	101.5	102.0	102.5	%
Ratio Between Fast OVP and $V_{REF}$	$K_{FOVP/VREF} = V_{FOVP}/V_{REF}$	$K_{FOVP/VREF}$	106	107	108	%
Bulk Undervoltage Threshold	$V_{FB} \text{ decreasing}$	$V_{BUV}$	–	2	–	V

# NCP1616

**Table 5. ELECTRICAL CHARACTERISTICS** ( $V_{CC} = 15\text{ V}$ ,  $V_{HV} = 120\text{ V}$ ,  $V_{FB} = 2.4\text{ V}$ ,  $C_{VControl} = 10\text{ nF}$ ,  $V_{FFcontrol} = 2.6\text{ V}$ ,  $V_{ZCD/CS} = 0\text{ V}$ ,  $V_{STDBY/FAULT} = 1\text{ V}$ ,  $C_{DRV} = 1\text{ nF}$ , for typical values  $T_J = 25^\circ\text{C}$ , for min/max values,  $T_J$  is  $-40^\circ\text{C}$  to  $125^\circ\text{C}$ , unless otherwise noted)

Characteristics	Conditions	Symbol	Min	Typ	Max	Unit
<b>FAST OVERVOLTAGE AND BULK UNDERVOLTAGE PROTECTION ON FB PIN</b>						
Undervoltage Protection Threshold to $V_{REF}$ Ratio	$V_{FB}$ decreasing, $V_{BUV}/V_{REF}$	$K_{BUV}/V_{REF}$	78	80	82	%
<b>LINE OVP (NCP1616A1 ONLY)</b>						
Ratio Between Line OVP and $V_{REF}$	$V_{FB}$ increasing	$K_{LOVP}$	110.5	112.0	113.5	%
Line Overvoltage Threshold		$V_{LOVP}$	–	2.8	–	V
Line Overvoltage Filter	$V_{FB}$ increasing	$t_{LOVP}(\text{blank})$	40	52.5	65	$\mu\text{s}$
<b>STANDBY FUNCTION ON STDBY/FAULT INPUT</b>						
Standby Input Threshold	$V_{STDBY/FAULT}$ decreasing	$V_{standby}$	285	300	315	mV
Standby Input Blanking Duration		$t_{blank}(\text{STDBY})$	0.8	1	1.2	ms
<b>RESTART FUNCTION ON FB PIN</b>						
Restart Threshold Ratio	$V_{Restart}/V_{REF}$	$K_{restart}$	93.5	94.0	94.5	%
Restart Threshold		$V_{restart}$	–	2.35	–	V
<b>BROWNOUT DETECTION</b>						
System Start-Up Threshold	$V_{HV}$ increasing	$V_{BO}(\text{start})$	102	111	118	V
System Shutdown Threshold	$V_{HV}$ decreasing	$V_{BO}(\text{stop})$	92	100	108	V
Hysteresis	$V_{HV}$ increasing	$V_{BO}(\text{HYS})$	7	11	–	V
Brownout Detection Blanking Time	$V_{HV}$ decreasing, delay from $V_{BO}(\text{stop})$ to drive disable	$t_{BO}(\text{stop})$	43	54	65	ms
Control Pin Sink Current in Brownout	$t_{BO}(\text{stop})$ expires	$I_{Control}(\text{BO})$	40	50	60	$\mu\text{A}$
<b>FAULT FUNCTION ON STDBY/FAULT INPUT</b>						
Overvoltage Protection (OVP) Threshold	$V_{STDBY/FAULT}$ increasing	$V_{Fault}(\text{OVP})$	2.79	3.00	3.21	V
Delay Before Fault Confirmation Used for OVP Detection	$V_{STDBY/FAULT}$ increasing	$t_{delay}(\text{OVP})$	22.5	30.0	37.5	$\mu\text{s}$
Fault Input Pull-Up Current Source	$V_{STDBY/FAULT} = V_{Fault}(\text{OVP})$	$I_{Fault}(\text{bias})$	50	200	450	nA
<b>THERMAL SHUTDOWN</b>						
Thermal Shutdown	Temperature increasing	$T_{SHDN}$	–	150	–	$^\circ\text{C}$
Thermal Shutdown Hysteresis	Temperature decreasing	$T_{SHDN}(\text{HYS})$	–	50	–	$^\circ\text{C}$

Product parametric performance is indicated in the Electrical Characteristics for the listed test conditions, unless otherwise noted. Product performance may not be indicated by the Electrical Characteristics if operated under different conditions.

## DETAILED OPERATING DESCRIPTION

## INTRODUCTION

The NCP1616 is designed to optimize the efficiency of your PFC stage throughout the load range. In addition, it incorporates protection features for rugged operation. More generally, the NCP1616 is ideal in systems where cost effectiveness, reliability, low standby power and high efficiency are the key requirements:

- **Current Controlled Frequency Foldback:** the NCP1616 operates in Current Controlled Frequency Foldback (CCFF). In this mode, the circuit operates in classical Critical conduction Mode (CrM) when the inductor current exceeds a programmable value. When the current falls below this preset level, the NCP1616 linearly reduces the operating frequency down to a minimum of about 26 kHz when the input current reaches zero. CCFF maximizes the efficiency at both nominal and light load. In particular, standby losses are reduced to a minimum. Similar to frequency clamped CrM controllers, internal circuitry allows near-unity power factor at lower output power.
- **Skip Mode:** to further optimize the efficiency, the circuit skips cycles near the line zero crossing when the current is very low. This is to avoid circuit operation when the power transfer is particularly inefficient at the cost of input current distortion. When superior power factor is required, this function can be inhibited by offsetting the FFcontrol pin by 0.75 V.
- **Integrated High Voltage Start-Up Circuit:** Eliminates the need of external start-up components. It is also used to discharge the input filter capacitors when the line is removed.
- **Line Removal Detection Circuitry:** reduces input power by eliminating external resistors for discharging the input filter capacitor.
- **Fast Line / Load Transient Compensation (Dynamic Response Enhancer):** since PFC stages exhibit low loop bandwidth, abrupt changes in the load or input voltage (e.g. at start-up) may cause an excessive over or undervoltage condition. This circuit limits possible deviations from the regulation level as follows:
  - ◆ The soft and fast Overvoltage Protections accurately limit the PFC stage maximum output voltage.
  - ◆ The NCP1616 dramatically speeds up the regulation loop when the output voltage falls below 95.5% of its regulation level. This function is disabled during power up to achieve a soft-start.
- **Standby Mode Input:** allows the downstream converter to inhibit the PFC drive pulses when the load is reduced.
- **Safety Protections:** the NCP1616 permanently monitors the input and output voltages, the MOSFET current and the die temperature to protect the system during fault conditions making the PFC stage extremely robust and

reliable. In addition to the bulk overvoltage protection, the NCP1616 include:

- ◆ **Maximum Current Limit:** the circuit senses the MOSFET current and turns off the power switch if the maximum current limit is exceeded. In addition, the circuit enters a low duty-ratio operation mode when the current reaches 150% of the current limit as a result of inductor saturation or a short of the bypass/boost diode.
- ◆ **Undervoltage Protection (UVP):** this circuit turns off when it detects that the output voltage is below 12% of the voltage reference (typically). This feature protects the PFC stage if the ac line is too low or if there is a failure in the feedback network (e.g., bad connection).
- ◆ **Bulk Undervoltage Detection (BUV):** the circuit monitors the output voltage to detect when the PFC stage cannot regulate the bulk voltage (BUV fault). When the BUV fault is detected, the control pin is gradually discharged.
- ◆ **Brownout Detection:** the circuit detects low ac line conditions and stops operation thus protecting the PFC stage from excessive stress.
- ◆ **Thermal Shutdown:** an internal thermal circuitry disables the gate drive when the junction temperature exceeds the thermal shutdown threshold.
- ◆ **A line overvoltage circuit** monitors the bulk voltage and disables the controller if voltage exceeds the overvoltage level.
- **Output Stage Totem Pole Driver:** the NCP1616 incorporates a 0.5 A source / 0.8 A sink gate driver to efficiently drive most medium to high power MOSFETs.

## HIGH VOLTAGE START-UP CIRCUIT

NCP1616 has an integrated high voltage start-up circuit accessible by the HV pin. The start-up circuit is rated at a maximum voltage of 700 V.

A start-up regulator consists of a constant current source that supplies current from a high voltage rail to the supply capacitor on the  $V_{CC}$  pin ( $C_{VCC}$ ). The start-up circuit current ( $I_{start2}$ ) is typically 12 mA.  $I_{start2}$  is disabled if the  $V_{CC}$  pin is below  $V_{CC(inhibit)}$ . In this condition the start-up current is reduced to  $I_{start1}$ , typically 0.5 mA. The internal high voltage start-up circuit eliminates the need for external start-up components. In addition, this regulator reduces no load power and increase the system efficiency as it uses negligible power in the normal operation mode

Once  $C_{VCC}$  is charged to the start-up threshold,  $V_{CC(on)}$ , typically 17 V, the start-up regulator is disabled and the controller is enabled. The start-up regulator remains disabled until  $V_{CC}$  falls below the lower supply threshold,



$V_{CC(off)}$ , typically 9.0 V, is reached. Once reached, the PFC controller is disabled reducing the bias current consumption of the IC.

The controller is disabled once a fault is detected. The controller will restart next time  $V_{CC}$  reaches  $V_{CC(on)}$  or after all non-latching faults are removed.

The supply capacitor provides power to the controller during power up. The capacitor must be sized such that a  $V_{CC}$  voltage greater than  $V_{CC(off)}$  is maintained while the auxiliary supply voltage is building up. Otherwise,  $V_{CC}$  will collapse and the controller will turn off. The operating IC bias current,  $I_{CC5}$ , and gate charge load at the drive outputs must be considered to correctly size  $C_{VCC}$ . The increase in current consumption due to external gate charge is calculated using Equation 1.

$$I_{CC(gatecharge)} = f \cdot Q_G \quad (\text{eq. 1})$$

where  $f$  is the operating frequency and  $Q_G$  is the gate charge of the external MOSFETs.

**OPERATING MODE**

The NCP1616 PFC controller achieves power factor correction using the novel Current Controlled Frequency Foldback (CCFF) topology. In CCFF the circuit operates in the classical critical conduction mode (CrM) when the inductor current exceeds a programmable value. Once the current falls below this preset level, the frequency is linearly reduced, reaching about 26 kHz when the current is zero.

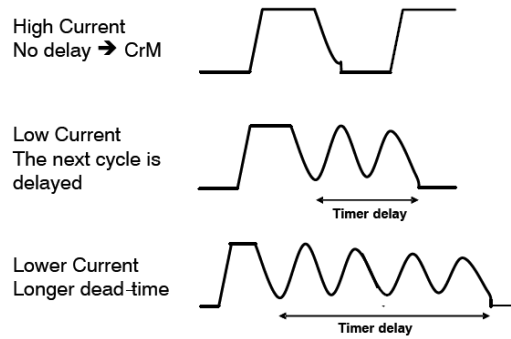

**Figure 3. CCFF Operation**

As illustrated in the top waveform in Figure 3, at high load, the boost stage operates in CrM. As the load decreases, the controller operates in a controlled frequency discontinuous mode.

Figure 4 details CCFF operation. A voltage representative of the input current (“current information”) is generated. If this signal is higher than a 2.5 V internal reference (named “Dead-Time Ramp Threshold”), there is no deadtime and the circuit operates in CrM. If the current information signal is lower than the 2.5 V threshold, deadtime is added. The deadtime is the time necessary for the internal ramp to reach 2.5 V from the current information floor. Hence, the lower the current information is, the longer the deadtime.

To further reduce the losses, the MOSFET turn on is further delayed until its drain-source voltage is at its valley. As illustrated in Figure 4, the ramp is synchronized to the drain-source ringing. If the ramp exceeds the 2.5 V threshold while the drain-source voltage is below  $V_{in}$ , the ramp is extended until it oscillates above  $V_{in}$  so that the drive will turn on at the next valley.

# NCP1616

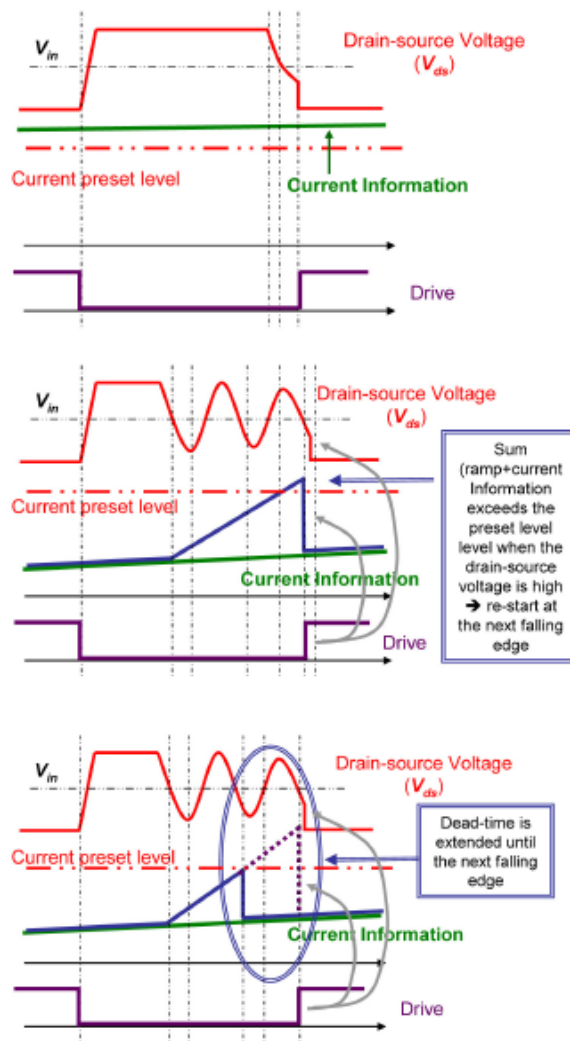

**Top:** CrM operation when the current information exceeds the preset level during the demagnetization phase  
**Middle:** the circuit re-starts at the next valley if the sum (ramp + current information) exceeds the preset level during the dead-time, while the drain-source voltage is high  
**Bottom:** the sum (ramp + current information) exceeds the preset level while during the dead-time, the drain-source voltage is low. The circuit skips the current valley and re-starts at the following one.

**Figure 4. Dead-Time Generation**

## CURRENT INFORMATION GENERATION

The FFcontrol pin sources a current that is representative of the input current. In practice,  $I_{FFcontrol}$  is built by multiplying the internal control signal ( $V_{REGUL}$ , i.e., the internal signal that controls the on time) by the internal sense voltage ( $V_{SENSE}$ ) that is proportional to the input voltage seen on the HV pin (see Figure 5).

The multiplier gain ( $K_m$  of Figure 5) is less in high line conditions (that is when the “LLine” signal from the brownout block is in low state) to ensure that the  $I_{FFcontrol}$  current is not influenced by the larger magnitude of  $V_{SENSE}$ .

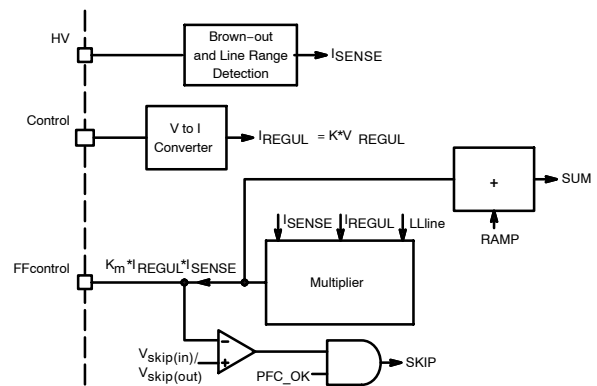

**Figure 5. Generation of the Current Information in the NCP1616**

**SKIP MODE**

As illustrated in Figure 5 the circuit also skips cycles near the line zero crossing where the current is very low and subsequently the voltage across RFF is low. A comparator monitors  $V_{FFcontrol}$  and inhibits the switching operation when  $V_{FFcontrol}$  falls below the skip level,  $V_{skip(in)}$ , typically 0.65 V. Switching resumes when  $V_{FFcontrol}$  exceeds the skip exit threshold,  $V_{skip(out)}$ , typically 0.75 V (100 mV hysteresis). This function disables the driver to reduce power dissipation when the power transfer is particularly inefficient at the expense of slightly increased input current distortion. When superior power factor is needed, this

function can be inhibited offsetting the FFcontrol pin by 0.75 V. The skip mode capability is disabled whenever the PFC stage is not in nominal operation represented by the PFCOK signal.

The circuit does not abruptly interrupt the switching when  $V_{FFcontrol}$  falls below  $V_{skip(in)}$ . Instead, the signal  $V_{TON}$  that controls the on time is gradually decreased by grounding the  $V_{REGUL}$  signal applied to the  $V_{TON}$  processing block shown in Figure 10. Doing so, the on time smoothly decays to zero in 3 to 4 switching periods typically. Figure 6 shows the practical implementation of the FFcontrol circuitry.

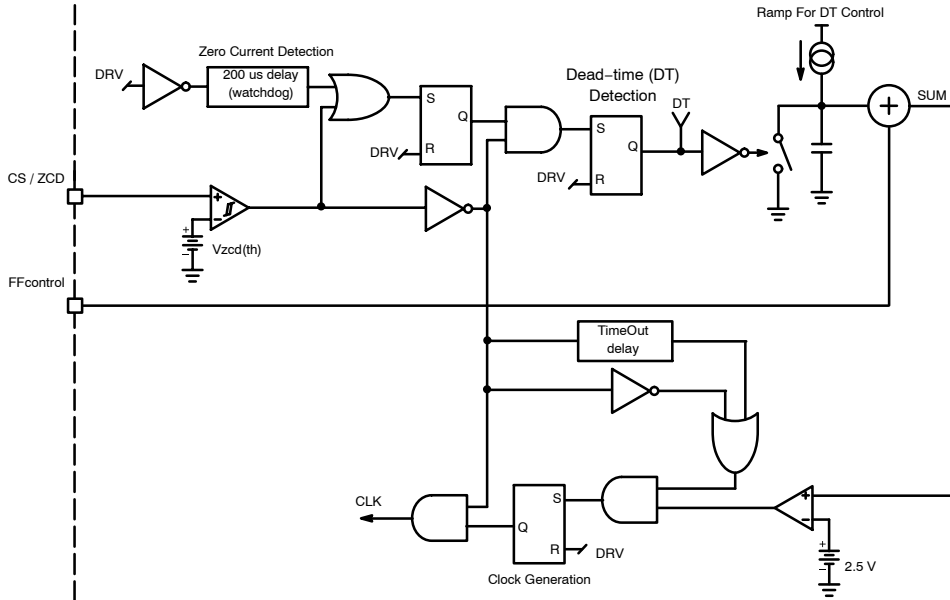

**Figure 6. CCFF Practical Implementation**

CCFF maximizes the efficiency at both nominal and light load. In particular, the standby losses are reduced to a minimum. Also, this method avoids that the system stalls or jumps between drain voltage valleys. Instead, the circuit acts

so that the PFC stage transitions from the  $n$  valley to  $(n + 1)$  valley or vice versa from the  $n$  valley to  $(n - 1)$  cleanly as illustrated by Figure 7.

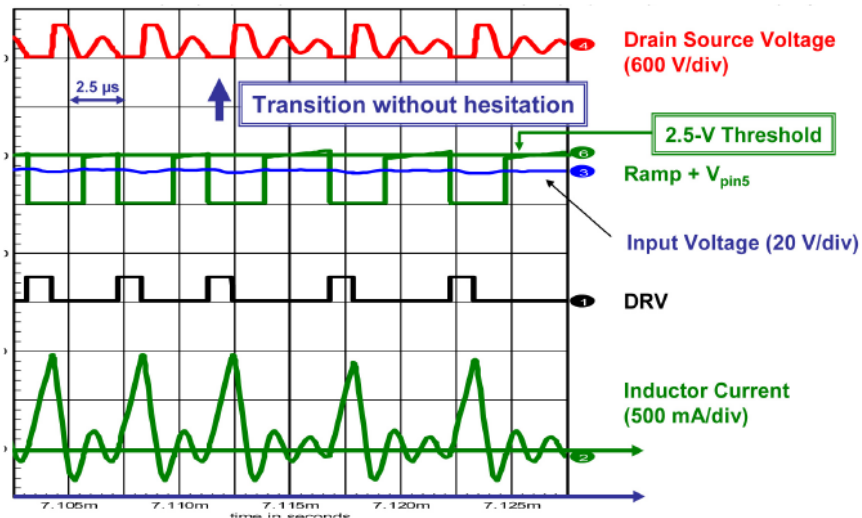

**Figure 7. Valley Transitions Without Valley Jumping**

**ON TIME MODULATION**

Let's analyze the ac line current absorbed by the PFC boost stage. The initial inductor current at the beginning of each switching cycle is always zero. The coil current ramps up when the MOSFET is on. The slope is  $(V_{in}/L)$  where  $L$  is the coil inductance. At the end of the on time period ( $t_1$ ), the inductor starts to demagnetize. The inductor current ramps down until it reaches zero. The duration of this phase is ( $t_2$ ). In some cases, the system enters then the dead-time ( $t_3$ ) that lasts until the next clock is generated.

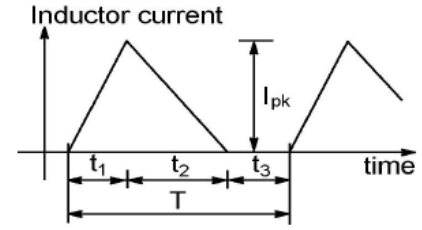
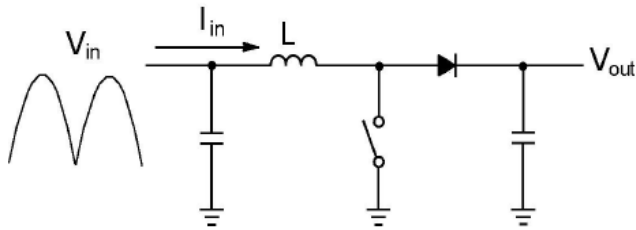

**Figure 8. PFC Boost Converter (left) and Inductor Current in DCM (right)**

The NCP1616 operates in voltage mode. As portrayed by Figure 9,  $t_1$  is controlled by the signal  $V_{TON}$  generated by the regulation block and an internal ramp as follows:

$$t_1 = \frac{C_{ramp} \cdot V_{TON}}{I_{ch}} \quad (eq. 3)$$

The charge current is constant at a given input voltage (as mentioned, it is three times higher at high line compared to its value at low line).  $C_{ramp}$  is an internal timing capacitor.

The output of the regulation block,  $V_{Control}$ , is linearly transformed into the signal  $V_{REGUL}$  varying between 0 and 1.5 V.  $V_{REGUL}$  is the voltage that is injected into the PWM section to modulate the MOSFET duty ratio. The NCP1616 includes circuitry that processes  $V_{REGUL}$  to generate the  $V_{TON}$  signal that is used in the PWM section (see Figure 10). It is modulated in response to the deadtime sensed during the precedent current cycles, that is, for a proper shaping of the ac line current. This modulation leads to:

$$V_{TON} = \frac{T \cdot V_{REGUL}}{t_1 + t_2} \quad (eq. 4)$$

or

$$V_{TON} \cdot \frac{(t_1 + t_2)}{T} = V_{REGUL}$$

Given the low regulation bandwidth of the PFC systems,  $V_{Control}$  and thus  $V_{REGUL}$  are slow varying signals. Hence, the  $(V_{ton} \cdot (t_1 + t_2)/T)$  term is substantially constant. Provided that during  $t_1$  it is proportional to  $V_{TON}$ , Equation 2 leads to:

$$I_{in} = k \cdot V_{in},$$

where  $k$  is a constant.

$$k = \text{constant} = \left[ \frac{1}{2L} \cdot \frac{V_{REGUL}}{V_{REGUL(MAX)}} \cdot t_{on(MAX)} \right]$$

One can show that the ac line current is given by:

$$I_{in} = V_{in} \left[ \frac{t_1(t_1 + t_2)}{2TL} \right] \quad (eq. 2)$$

Where  $T = (t_1 + t_2 + t_3)$  is the switching period and  $V_{in}$  is the ac line rectified voltage.

In light of this equation, we immediately note that  $I_{in}$  is proportional to  $V_{in}$  if  $[t_1 \cdot (t_1 + t_2)/T]$  is a constant.

Where  $t_{on(MAX)}$  is the maximum on time obtained when  $V_{REGUL}$  is at its maximum level,  $V_{REGUL(MAX)}$ . The parametric table shows that  $t_{on(MAX)}$  is equal to 25  $\mu s$  ( $t_{on(LL)}$ ) at low line and to 8.1  $\mu s$  ( $t_{on(HL)}$ ) at high line. Hence, we can rewrite the above equation as follows:

$$I_{in} = \frac{V_{in} \cdot t_{on(LL)}}{2 \cdot L} \cdot \frac{V_{REGUL}}{V_{REGUL(MAX)}}$$

at low line.

$$I_{in} = \frac{V_{in} \cdot t_{on(HL)}}{2 \cdot L} \cdot \frac{V_{REGUL}}{V_{REGUL(MAX)}}$$

From these equations, we can deduce the expression of the average input power at low line as shown below:

$$P_{in(ave)} = \frac{V_{in,rms}^2 \cdot t_{on(LL)} \cdot V_{REGUL}}{2 \cdot L \cdot V_{REGUL(MAX)}}$$

The input power at high line is shown below:

$$P_{in(ave)} = \frac{V_{in,rms}^2 \cdot t_{on(HL)} \cdot V_{REGUL}}{2 \cdot L \cdot V_{REGUL(MAX)}}$$

Hence, the maximum power that can be delivered by the PFC stage at low line is given by equation below:

$$P_{in(MAX)} = \frac{V_{in,rms}^2 \cdot t_{on(LL)}}{2 \cdot L}$$

The maximum power at high line is given by the equation below:

$$P_{in(MAX)} = \frac{V_{in,rms}^2 \cdot t_{on(HL)}}{2 \cdot L}$$

The input current is then proportional to the input voltage resulting in a properly shaped ac line current.

One can note that this analysis is also valid in CrM operation. This condition is just a particular case of this functioning where ( $t_3 = 0$ ), which leads to ( $t_1 + t_2 = T$ ) and ( $V_{TON} = V_{REGUL}$ ). That is why the NCP1616 automatically adapts to the conditions and transitions from DCM to CrM (and vice versa) without power factor degradation and without discontinuity in the power delivery.

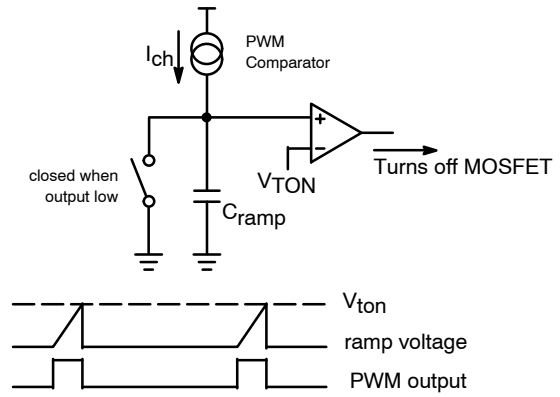

Figure 9. PWM Circuit and Timing Diagram

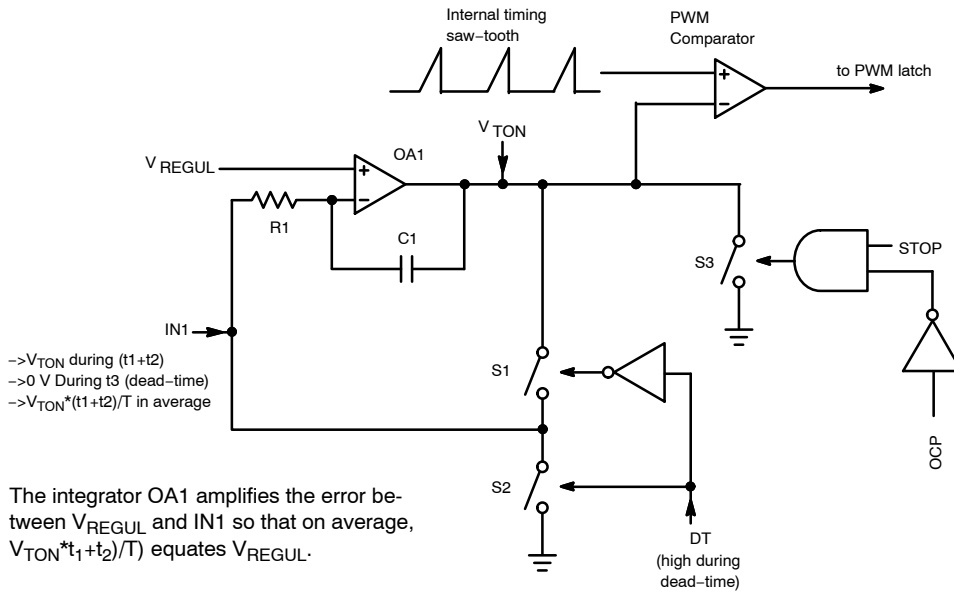

Figure 10.  $V_{TON}$  Processing Circuit

It is important to note that the “ $V_{TON}$  processing circuit” compensates for long interruption of the driver activity by grounding the  $V_{TON}$  signal as shown in Figure 10. Long driver interruptions are represented by the STOP signal. Such faults (excluding OCP) are BUV\_fault, OVP, BONOK, OverStress, SKIP, staticOVP, Fast-OVP, RestartNOK and OFF mode. Otherwise, a long off time will be interpreted as normal deadtime and the circuit would over dimension  $V_{TON}$  to compensate it. Grounding the  $V_{TON}$  signal leads to a short soft-start period due to ramp up of  $V_{TON}$ . This helps reduce the risk of acoustic noise.

**VOLTAGE REFERENCE**

A transconductance error amplifier regulates the PFC output voltage,  $V_{bulk}$ , by comparing the PFC feedback signal to an internal reference voltage,  $V_{REF}$ . The feedback signal is applied to the inverting input and the reference is connected to the non-inverting input of the error amplifier. A resistor divider scales down  $V_{bulk}$  to generate the PFC feedback signal.  $V_{REF}$  is trimmed during manufacturing to achieve an accuracy of  $\pm 2.4\%$ .

**REGULATION BLOCK AND LOW OUTPUT VOLTAGE DETECTION**

A transconductance error amplifier (OTA) with access to the inverting input and output is provided. Access to the inverting input is provided by the FB pin and the output is accessible through the Control pin. The OTA features a typical transconductance gain,  $g_m$ , of 210  $\mu S$ . The amplifier source and sink currents,  $I_{EA(SRC)}$  and  $I_{EA(SNK)}$ , are typically 20  $\mu A$ .

The output voltage of the PFC stage is typically scaled down by a resistors divider and fed into the FB pin. The pin input bias current is minimized (less than 500 nA) to allow the use of a high impedance feedback network. At the same time, the bias current is enough to effectively ground the FB if the pin is open or floating.

The output of the error amplifier is brought to the Control pin for external loop compensation. The compensation network on the Control pin is selected to filter the bulk voltage ripple such that a constant control voltage is maintained across the ac line cycle and provide adequate phase boost. Typically a type 2 network is used, to set the

regulation bandwidth below about 20 Hz and to provide a decent phase boost.

The minimum control voltage,  $V_{Control(MIN)}$  is typically 0.5 V and it is set by an internal diode drop or  $V_F$ . Maximum control voltage,  $V_{Control(MAX)}$  is typically 4.5 V. Therefore, the  $V_{Control}$  swing is 4 V.  $V_{Control}$  is offset down by a  $V_F$  and

scaled down by a resistor divider before it connects to the “ $V_{TON}$  processing block” and the PWM section as shown in Figure 11. The output of the regulation block is a signal (“ $V_{REGUL}$ ” of the block diagram) that varies between 0 and a maximum value corresponding to the maximum on-time.

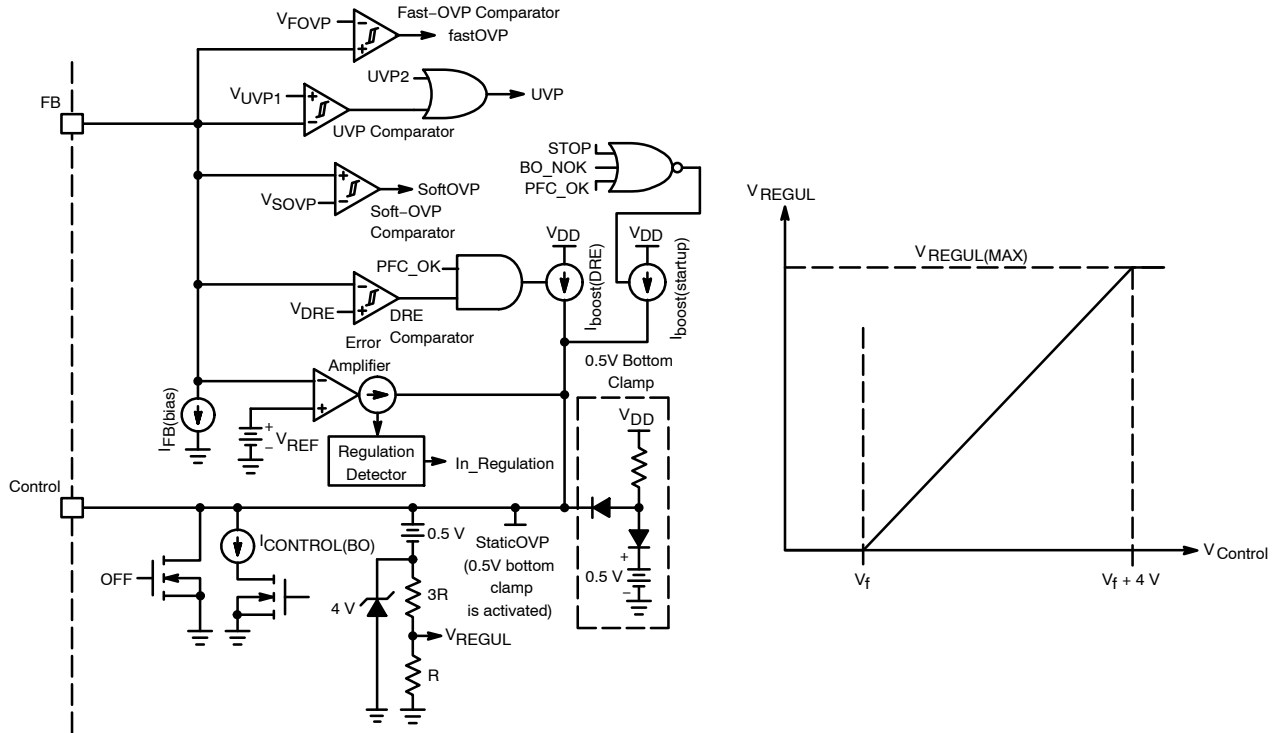

Figure 11. Regulation Block Diagram (left) Correspondence Between  $V_{control}$  and  $V_{REGUL}$  (right)

Given the low bandwidth of the regulation loop, abrupt variations of the load, may result in excessive over or undershoots.

The NCP1616 embeds a “dynamic response enhancer” circuitry (DRE) that limits output voltage undershoots. An internal comparator monitors the FB pin and if its voltage falls below 95.5% of its nominal value, it enables a pull-up current source,  $I_{boost(DRE)}$ , to increase the Control voltage by charging the compensation network and bring the system into regulation. The total current sourced from the Control Pin during DRE,  $I_{Control(DRE)}$ , is typically 220  $\mu A$ . This effectively appears as a 10x increase in the loop gain.

A reduced current source,  $I_{boost(start-up)}$  (typically 80  $\mu A$ ), is enabled to speed up the start-up sequence and achieve a faster start-up time.  $I_{boost(start-up)}$  is disabled when faults (i.e. Brownout) are detected.

Voltage overshoots are limited by the Soft Overvoltage Protection (SOVP) connected to the FB pin. The circuit reduces the power delivery when the output voltage exceeds 105% of its desired level. The NCP1616 does not abruptly interrupt the switching. Instead, the  $V_{TON}$  signal that controls the on time is gradually decreased by grounding the  $V_{REGUL}$  signal applied to the  $V_{TON}$  processing block as

shown in Figure 10. Doing so, the on time smoothly decays to zero in 3 to 4 cycles. If the output voltage keeps increasing, the Fast Overvoltage Protection (FOVP) comparator immediately disables the driver when the output voltage exceeds 107% of its desired level.

The Undervoltage (UVP) Comparator monitors the FB voltage and disables the PFC stage if the bulk voltage falls below 12% of its regulation level. Once an undervoltage fault is detected, the PFCOK signal goes low to disable the downstream converter and the control capacitor is grounded.

The Bulk Undervoltage Comparator (BUV) monitors the bulk voltage and disables the controller if the BUV voltage falls below the BUV threshold. The BUV threshold is a ratio of  $V_{REF}$  and it is given by  $K_{BUV}/V_{REF}$ , typically 80% of  $V_{REF}$ . Once a BUV fault is detected the controller is disabled and the PFCOK signal goes low. The Control capacitor is slowly discharged until it falls below the skip level. The discharge delay forces a minimum off time for the downstream converter. Once the discharge phase is complete the circuit may attempt to restart if  $V_{CC}$  is above  $V_{CC(on)}$ . Otherwise, it will restart at the next  $V_{CC(on)}$ . The BUV fault is blanked while the PFCOK signal is low (i.e. during start-up) to allow a correct start-up sequence.

A dedicated comparator monitors the FB voltage to detect the presence of a line overvoltage (LOVP) fault. The line overvoltage threshold,  $V_{FB(LOVP)}$ , is typically 112.5%. A timer,  $t_{LOVP(blank)}$ , typically 50  $\mu s$ , blanks the line detect signal to prevent false detection during line transients and surge. Once a line OVP fault is detected the converter is latched.

The input to the Error Amplifier, the soft-OVP, line OVP, UVP and DRE Comparators is the FB pin. The table below shows the relationship between the nominal output voltage,  $V_{out(NOM)}$ , and the DRE, soft-OVP, Fast-OVP, line OVP and UVP levels.

Parameter	Symbol/Value
Nominal Output Voltage	$V_{out(NOM)}$
DRE Threshold	$V_{out(NOM)} * 95.5\%$
Soft-OVP	$V_{out(NOM)} * 105\%$
UVP	$V_{out(NOM)} * 12\%$
Fast-OVP	$V_{out(NOM)} * 107\%$
Line OVP (Version A1 only)	$V_{out(NOM)} * 112\%$

**CURRENT SENSE AND ZERO CURRENT DETECTION**

The NCP1616 combines the PFC current sense and zero current detectors (ZCD) in a single input terminal, CS/ZCD. Figure 12 shows the circuit schematic of the current sense and ZCD detectors.

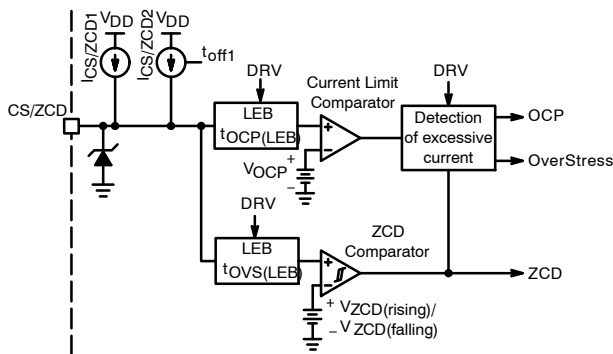

**Figure 12. PFC Current Sense and ZCD Detectors Schematic**

**Current Sense**

The PFC Switch current is sensed across a sense resistor,  $R_{sense}$ , and the resulting voltage ramp is applied to the CS/ZCD pin. The current signal is blanked by a leading edge blanking (LEB) circuit. The blanking period eliminates the leading edge spike and high frequency noise during the switch turn-on event. The LEB period,  $t_{OCP(LEB)}$ , is typically 200 ns. The Current Limit Comparator disables the driver once the current sense signal exceeds the overcurrent threshold,  $V_{OCP}$ , typically 0.5 V.

**PFC Zero Current Detection**

The CS pin is also designed to receive a signal from an auxiliary winding to detect the inductor demagnetization or for zero current detection (ZCD). This winding is commonly known as a zero crossing detector (ZCD) winding. This winding provides a scaled version of the inductor voltage. Figure 13 shows the ZCD winding arrangement.

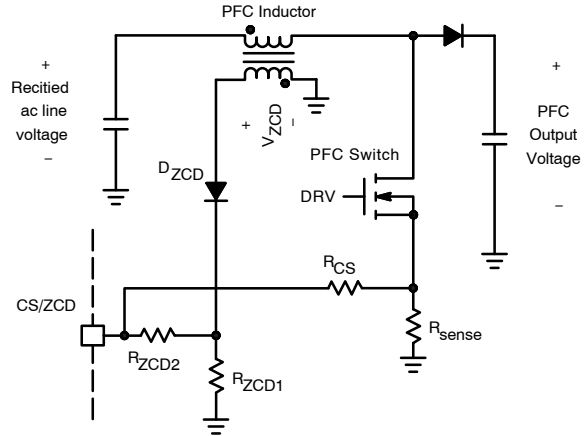

**Figure 13. ZCD Winding Implementation**

The ZCD winding voltage,  $V_{ZCD}$ , is positive while the PFC Switch is off and the inductor current decays to zero.  $V_{ZCD}$  drops to and rings around zero volts once the inductor is demagnetized. The ZCD winding voltage is applied through a diode,  $D_{ZCD}$ , to prevent this signal from distorting the current sense information during the on time. Therefore, the overcurrent protection is not impacted by the ZCD sensing circuitry.

As illustrated in Figure 12, an internal ZCD Comparator monitors the CS/ZCD voltage,  $V_{CS/ZCD}$ . The start of the demagnetization phase is detected (signal ZCD is high) once  $V_{CS/ZCD}$  exceeds the ZCD arming threshold,  $V_{ZCD(rising)}$ , typically 750 mV. This comparator is able to detect ZCD pulses with a duration longer than 200 ns. When  $V_{CS/ZCD}$  drops below the lower or trigger ZCD threshold,  $V_{ZCD(falling)}$ , the end of the demagnetization phase is detected and the driver goes high within 200 ns.

When a ZCD signal is not detected during start-up or during the off time, an internal watchdog timer,  $t_{off1}$ , initiates the next drive pulse. The watchdog timer duration is typically 200  $\mu s$ . Once the watchdog timer expires the circuit senses the impedance at the CS/ZCD pin to detect if the pin is shorted and disable the controller. The CS/ZCD external components must be selected to avoid false fault detection. The recommended minimum impedance connected to the CS/ZCD pin is 3.9 k $\Omega$ . Practically,  $R_{CS}$  in Figure 13 must be higher than 3.9 k $\Omega$ .

**BYPASS/BOOST DIODE SHORT CIRCUIT AND INRUSH CURRENT PROTECTION**

It may be possible to turn on the MOSFET while a high current flows through the inductor. Examples of this condition include start-up when large inrush current is present to charge the bulk capacitor. Traditionally, a bypass diode is generally placed between the input and output high-voltage rails to divert this inrush current. If this diode is accidentally shorted or damaged, the MOSFET will operate at a minimum on time but the current can be very high causing a significant temperature increase.

The NCP1616 operates in a very low duty ratio to reduce the MOSFET temperature and protect the system in this “Over Stress” condition. This is achieved by disabling the drive signal if the  $V_{ZCD(rising)}$  threshold is reached during the MOSFET conduction time. In this condition, a latch is set and the “OverStress” signal goes high. The driver is then disabled for a period determined by the overstress watchdog timer,  $t_{off2}$ , typically 1 ms. This longer delay leads to a very low duty-ratio operation to reduce the risk of overheating. This operation also protects the system in the event of a boost diode short.

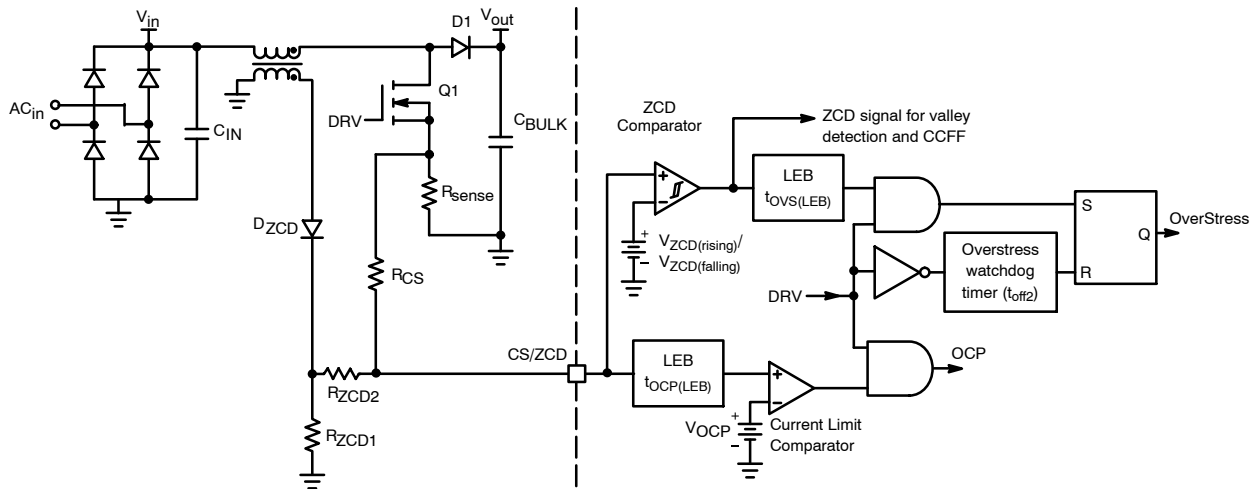

Figure 14. Current Sense and Zero Current Detection Blocks

**PFCOK LATCH**

The internal PFCOK latch is reset during the following conditions:

- During Start-Up: It remains low until the output voltage achieves regulation and the voltage stabilizes at the right level.
- Low Output Voltage: If the PFC stage output voltage is below the bulk undervoltage (BUV\_Fault) level, this is indicative of a fault.
- Brownout fault is detected (after discharge of control capacitor).
- Low supply voltage:  $V_{CC}$  falls below  $V_{CC(off)}$ .
- Feedback undervoltage fault.
- A fault is detected through the STDBY/FAULT pin.
- Open FB pin.
- Thermal Shutdown.
- Line voltage removal.

The circuit schematic of the PFCOK block is shown Figure 15.

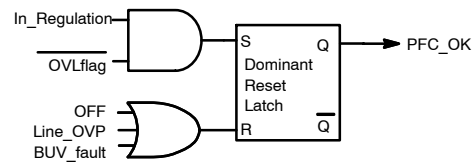

Figure 15. PFCOK Circuit Schematic

The PFCOK circuit monitors the current sourced by the OTA. The OTA current reaches zero when the output voltage has reached its nominal level. This is represented in the block diagram by the “In\_Regulation” Signal. The PFCOK signal goes high when the current reaches zero or falls below zero. The start-up phase is then complete and the PFCOK signal goes high until a fault is detected.

Another signal considered before setting the PFCOK signal is the BUV. The PFCOK signal will remain low until the bulk voltage is above the undervoltage threshold. The PFCOK signal will go low if the bulk voltage drops below its undervoltage threshold.

**BROWNOUT DETECTION**

The HV pin provides access to the brownout and line voltage detectors. It also provides access to the input filter capacitor discharge circuit. The brownout detector detects main interruptions and the line voltage detector determines the presence of either 110 V or 220 V ac mains. Depending on the detected input voltage range device parameters are internally adjusted to optimize the system performance.

Line and neutral are diode “ORed” before connecting to the HV pin as shown in Figure 16. The diodes prevent the pin voltage from going below ground. A low value resistor in series with the diodes can be used for protection. A low value resistor is needed to reduce the voltage offset while sensing the line voltage.

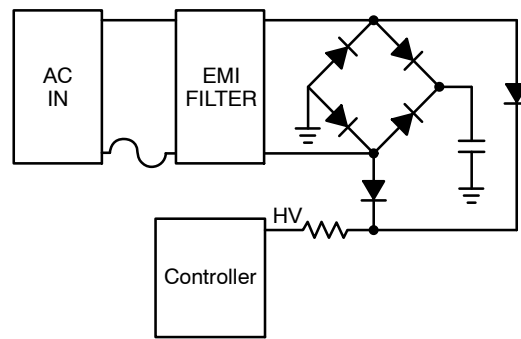

**Figure 16. High-Voltage Input Connection**

The controller is enabled once  $V_{HV}$  is above the brownout threshold,  $V_{BO(start)}$ , typically 111 V, and  $V_{CC}$  reaches  $V_{CC(on)}$ . Figure 17 shows typical power up waveforms.

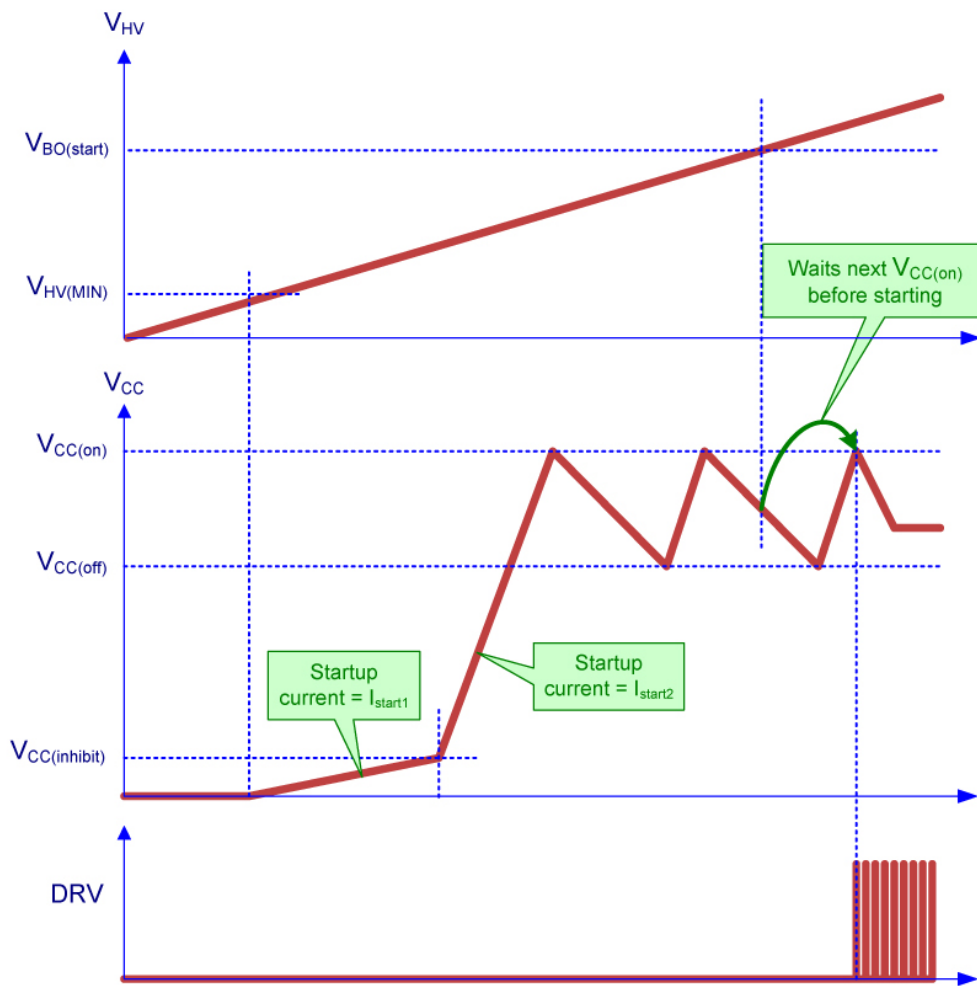

**Figure 17. Start-Up Timing Diagram**

A timer is enabled once  $V_{HV}$  drops below its disable threshold,  $V_{BO(stop)}$ , typically 100 V. The controller is disabled if  $V_{HV}$  doesn't exceed  $V_{BO(stop)}$  before the brownout timer expires,  $t_{BO}$ , typically 54 ms. The timer is

set long enough to ignore a single cycle dropout. The timer ramp starts charging once  $V_{HV}$  drops below  $V_{BO(stop)}$ . Figure 18 shows brownout detector waveforms during line dropout.

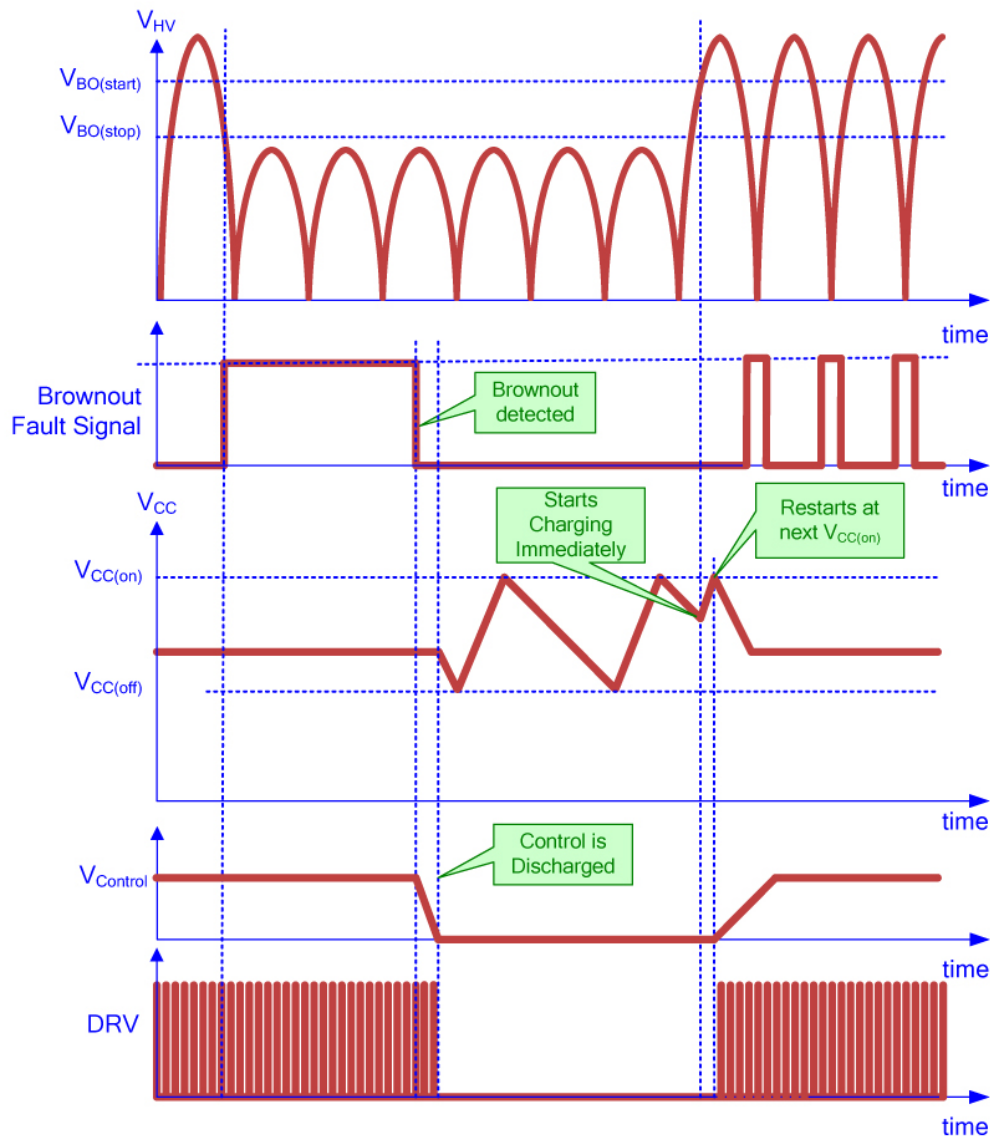

Figure 18. Brownout Operation During Line Dropout

**LINE RANGE DETECTOR**

The input voltage range is detected based on the peak voltage measured at the HV pin. The line range detection circuit allows more optimal loop gain control for universal (wide input mains) applications. Discrete values are selected for the PFC stage gain (feedforward) depending on the input voltage range.

The controller compares  $V_{HV}$  to the high line select threshold,  $V_{lineselect(HL)}$ , typically 236 V. Once  $V_{HV}$  exceeds  $V_{lineselect(HL)}$ , the PFC stage operates in “high line” (Europe/Asia) or “220 Vac” mode. In high line mode the loop gain is divided by three, thus the internal PWM ramp slope is three times steeper.

The default power-up mode of the controller is low line. The controller switches to “high line” mode if  $V_{HV}$  exceeds the high line select threshold for longer than the low to high

line timer,  $t_{delay(line)}$ , typically 300  $\mu s$  as long as it was not previously in high line mode. A lockout timer is started upon transitioning to “low line” mode. If the controller has switched to “low line” mode, it is prevented from switching back to “high line” mode until the valley detection lockout timer  $t_{line(lockout)}$  (typically 150 ms), expires. The timer and logic is included to prevent unwanted noise from toggling the operating line level.

In “high line” mode the high to low line timer,  $t_{line}$ , (typically 25 ms) is enabled once  $V_{HV}$  falls below  $V_{lineselect(LL)}$ , typically 222 V. It is reset if  $V_{HV}$  exceeds  $V_{lineselect(LL)}$ . The controller switches back to “low line” mode if the high to low line timer expires. Figure 19 shows operating waveforms of the line detector circuit. Figure 20 shows the operation of the lockout timer.

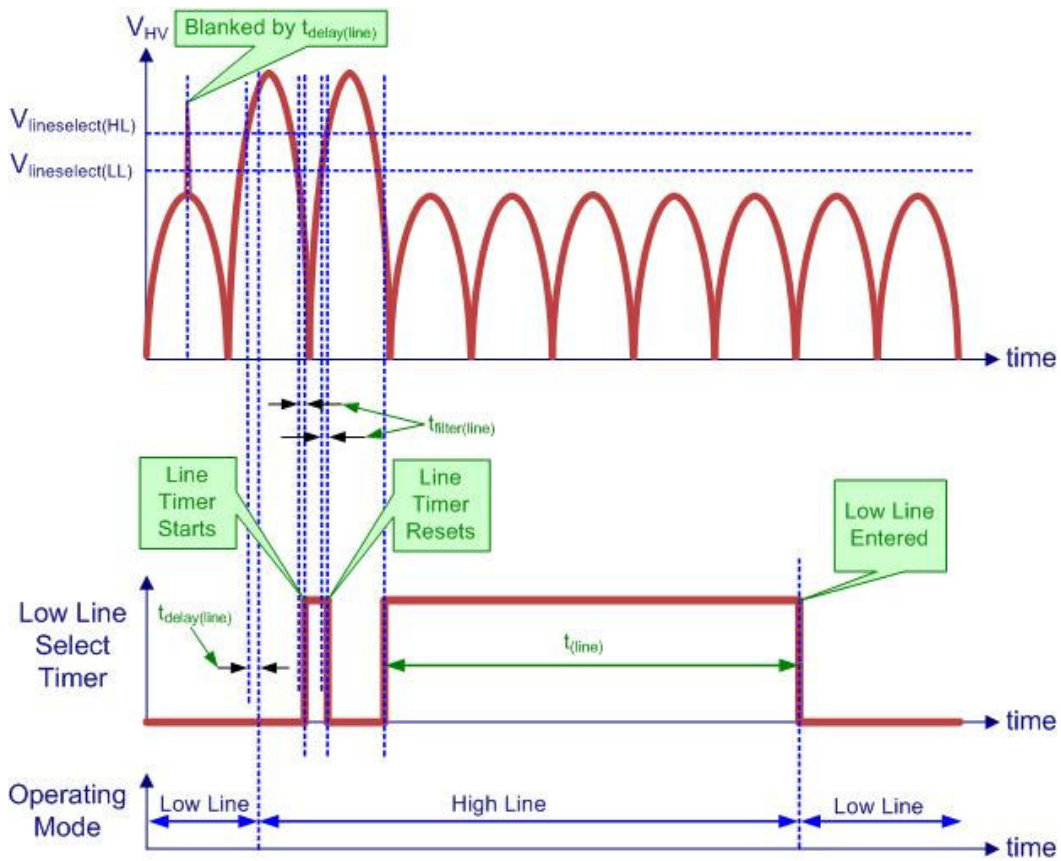

Figure 19. Line Detector Timing Waveforms

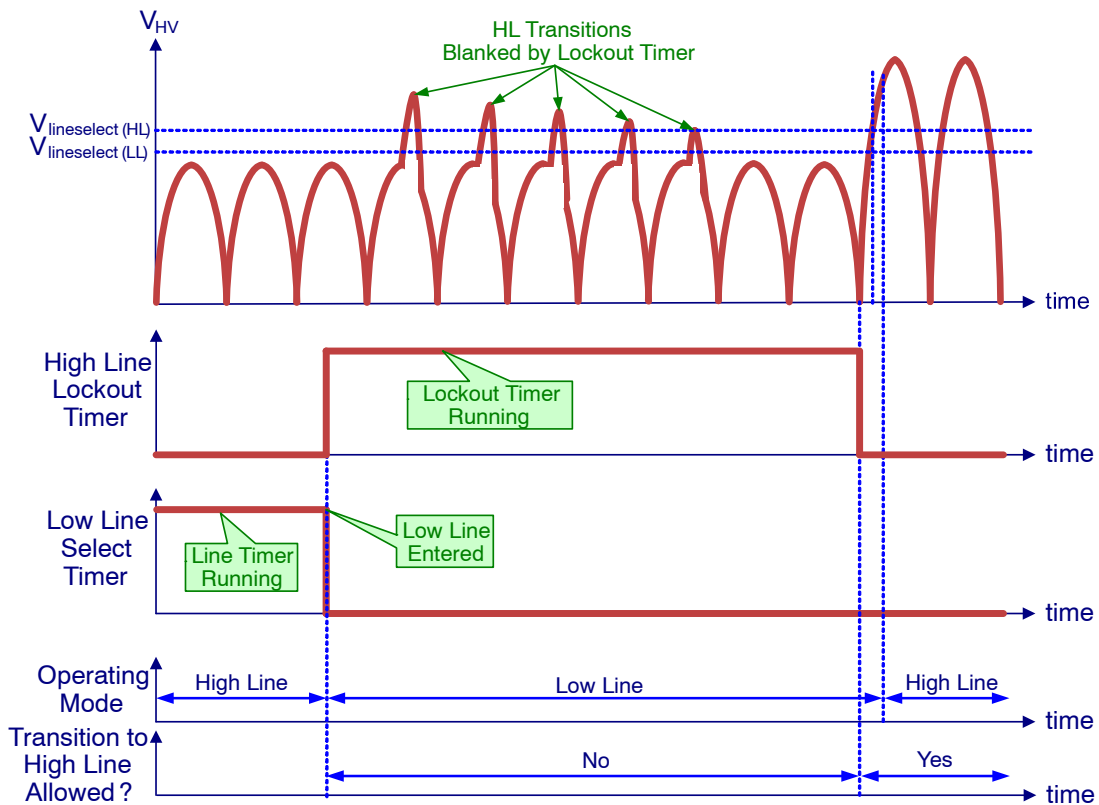

Figure 20. Lockout Timer Operation

## OUTPUT DRIVE SECTION

The NCP1616 incorporates a large MOSFET driver. It is a totem pole optimized to minimize the cross conduction current during high frequency operation. It has a high drive current capability ( $-500/+800$  mA) allowing the controller to effectively drive high gate charge power MOSFET.

The device maximum supply voltage,  $V_{CC(MAX)}$ , is 30 V. Typical high voltage MOSFETs have a maximum gate voltage rating of 20 V. The driver incorporates an active voltage clamp to limit the gate voltage on the external MOSFETs. The voltage clamp,  $V_{DRV(high)}$ , is typically 12 V with a maximum limit of 14 V.

The gate driver is kept in a sinking mode whenever the controller is disabled. This occurs when the Undervoltage Lockout is active or more generally whenever the controller detects a fault and enters off mode (i.e., when the “STDWN” signal of the block diagram is high).

## OFF MODE

The controller is disabled and in a low current mode if any of the following faults are detected:

- Low supply input voltage. An undervoltage (or UVLO) fault is detected if  $V_{CC}$  falls below  $V_{CC(off)}$ .
- Thermal shutdown is activated due to high die temperature.
- A brownout fault is detected.
- The controller enters skip mode
- A bulk undervoltage fault is detected.
- The controller enters latch mode.

Generally speaking, the circuit turns off when the conditions are not proper for desired operation. In this mode, the controller stops operation and most of the internal circuitry is disabled to reduce power consumption. Below is description of the IC operation in off mode:

- The driver is disabled.
- The controller maintains  $V_{CC}$  between  $V_{CC(on)}$  and  $V_{CC(off)}$ .
- The following blocks or features remain active:
  - ◆ Brownout detector.
  - ◆ Thermal shutdown.
  - ◆ The undervoltage protection (“UVP”) detector.
  - ◆ The overvoltage latch input remains active
- $V_{Control}$  is grounded to ensure a controlled start-up sequence once the fault is removed.
- The PFCOK latch is reset.
- The output of the “ $V_{TON}$  processing block” is grounded.

## SYSTEM FAILURE DETECTION

When manufacturing a power supply, elements can be accidentally shorted or improperly soldered. Such failures can also occur as the system ages due to component fatigue, excessive stress, soldering faults, or external interactions. In particular, a pin can be grounded, left open, or shorted to an

adjacent pin. Such open/short situations require a safe failure without smoke, fire, or loud noises. The NCP1616 integrates functions that ease meeting this requirement. Among them are:

- GND connection fault. If the GND pin is properly connected, the supply current drawn from the positive terminal of the VCC capacitor, flows out of the GND pin and returns to the negative terminal of the VCC capacitor. If the GND pin is disconnected, the internal ESD protection diodes provides a return path. An open or floating GND pin is detected if current flows in the CS/ZCD ESD diode. If current flow is detected for 200  $\mu$ s, a fault is acknowledged and the controller stops operating.
- Open CS/ZCD Pin: A pull-up current source,  $I_{CS/ZCD(bias1)}$ , on the CS/ZCD pin allows detection of an open CS/ZCD pin.  $I_{CS/ZCD1}$ , is typically 1  $\mu$ A. If the pin is open, the voltage on the pin will increase to the supply rail. This condition is detected and the controller is disabled.
- Grounded CS/ZCD Pin: If the CS/ZCD pin is grounded, the circuit cannot detect a ZCD transition, activating the watchdog timer (typically 200  $\mu$ s). Once the watchdog timer expires, a pull-up current source,  $I_{CS/ZCD2}$ , sources 250  $\mu$ A to pull-up the CS/ZCD pin. The driver is inhibited until the CS/ZCD pin voltage exceeds the ZCD arming threshold,  $V_{ZCD(rising)}$ , typically 0.75 V. Therefore, if the pin is grounded, the voltage on the pin will not exceed  $V_{ZCD(rising)}$  and drive pulses will be inhibited. The external impedance should be above 3.9 k $\Omega$  to ensure correct operation.
- Boost or bypass diode short. The NCP1616 addresses the short situations of the boost and bypass diodes (a bypass diode is generally placed between the input and output high-voltage rails to divert this inrush current). Practically, the overstress protection is implemented to detect such conditions and forces a low duty ratio operation until the fault is removed.

## FAULT INPUT

The NCP1616 controller can be latched by pulling up the STDBY/FAULT pin above the upper fault threshold,  $V_{Fault(OVP)}$ , typically 3.0 V. The Fault input signal is filtered to prevent noise from triggering the fault detection. Fault detector blanking delay,  $t_{delay(OVP)}$  is typically 30  $\mu$ s. A fault is detected if the fault condition is asserted for a period longer than the blanking delay.

Once the controller is latched, it is reset if a brownout condition is detected or if  $V_{CC}$  is cycled down to its reset level,  $V_{CC(reset)}$ . In the typical application these conditions occur only if the ac voltage is removed from the system. A 200 nA pull up current source,  $I_{Fault(bias)}$  triggers controller fault detection when the pin is left open.



**STANDBY OPERATION**

A signal proportional to the downstream converter output power is applied to the STDBY pin to enable standby mode operation. A STDBY voltage below the standby threshold,  $V_{standby}$ , typically 300 mV, forces the controller into a controlled burst mode, or standby mode.

In standby mode, the driver is disabled until the bulk voltage falls below the bulk restart level. At which point, the driver is re-enabled. The bulk restart level determines the minimum bulk voltage in standby mode. As long as the STBY pin voltage is below the standby threshold, the controller will operate in controlled burst mode.

The controller is not allowed to enter standby mode while the PFCOK signal is low. A dedicated timer,  $t_{blank}(STDBY)$ , blanks the standby signal for 1 ms (typically) right after the PFCOK signal transitions high. This ensures the signal proportional to the downstream converter output power has enough time to build up and prevent disabling the PFC while powering up the downstream converter. The standby circuit block is shown in Figure 21.

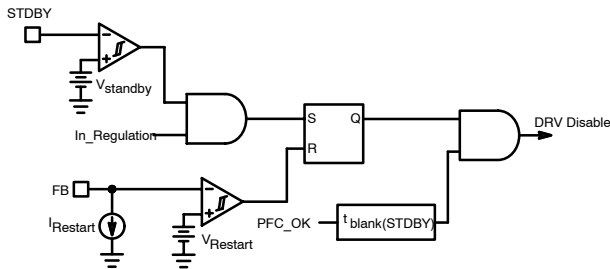

Figure 21. Standby Circuit Block

**ADJUSTABLE BULK VOLTAGE HYSTERESIS**

The bulk restart threshold allows the user to enable the bulk level at which the controller exits standby mode.

NCP1616 has the restart threshold ( $V_{Restart}$ ) set to 2.35 V, 6% below the internal reference,  $V_{REF}$ . The ratio between  $V_{REF}$  and the restart level is given by  $K_{Restart}$ .

**LINE REMOVAL**

Safety agency standards require the input filter capacitors to be discharged once the ac line voltage is removed. A resistor network is the most common method to meet this requirement. Unfortunately, the resistor network consumes power across all operating modes and it is a major contributor of input power losses during light-load and no-load conditions. The NCP1616 eliminates the need for external discharge resistors by integrating active input filter capacitor discharge circuitry. A novel approach is used to reconfigure the high voltage startup circuit to discharge the input filter capacitors upon removal of the ac line voltage. The line removal detection circuitry is always active to ensure safety compliance.

*Line Removal Detection*

The line removal is detected by digitally sampling the voltage present at the HV pin, and monitoring the magnitude of the slope.

A timer,  $t_{line(removal)}$  (typically 100 ms), starts running when the slope magnitude of the input signal is below a minimum level. The timer is reset by the upslope detection reset timer  $t_{HV(up)}$  (typically 14 ms) or the downslope detection reset timer  $t_{HV(down)}$  (typically 1 ms). Once the timer expires, a line removal condition is acknowledged initiating an HV discharge cycle, and disabling the controller. This operation is depicted in Figure 22.

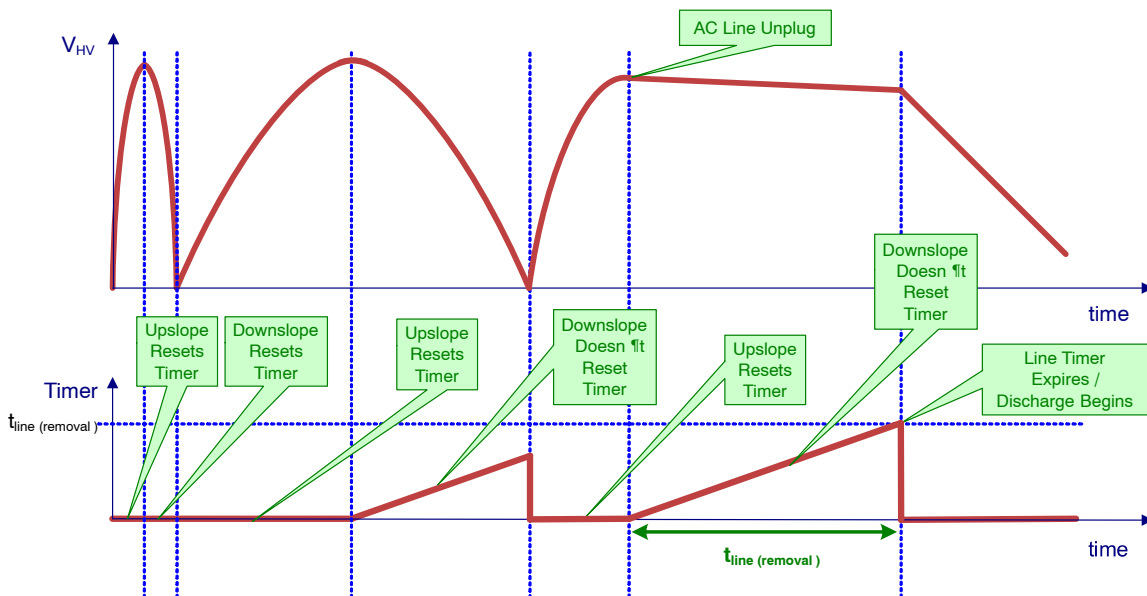

Figure 22. Line Removal Detection Timing

*Capacitor Discharge*

During the discharge phase, the discharge current source  $I_{HV(discharge)}$  (typically 4 mA) is activated. The current source remains active and constant until  $V_{HV}$  drops to  $V_{HV(discharge)}$  (typically 30 V). At this point, it begins to pinch off until the discharge phase completes. Once the discharge phase completes, a new start-up cycle commences as normal. This circuit is shown in Figure 23, while the operation is depicted in Figure 24.

Safety agency standards require the input filter capacitors to be discharged once the ac line voltage is removed. A resistor network is the most common method to meet this

requirement. Unfortunately, the resistor network consumes power across all operating modes and it is a major contributor of input power losses during light-load and no-load conditions.

**It is important to note that the HV pin cannot be connected to any dc voltage due to this feature, i.e. directly to the bulk capacitor.**

In the event that line voltage is reapplied during a discharge phase, the circuit will simply continue to discharge until the line zero crossing occurs, at which point  $V_{HV}$  will drop to  $V_{HV(discharge)}$  and a new start-up cycle will commence.

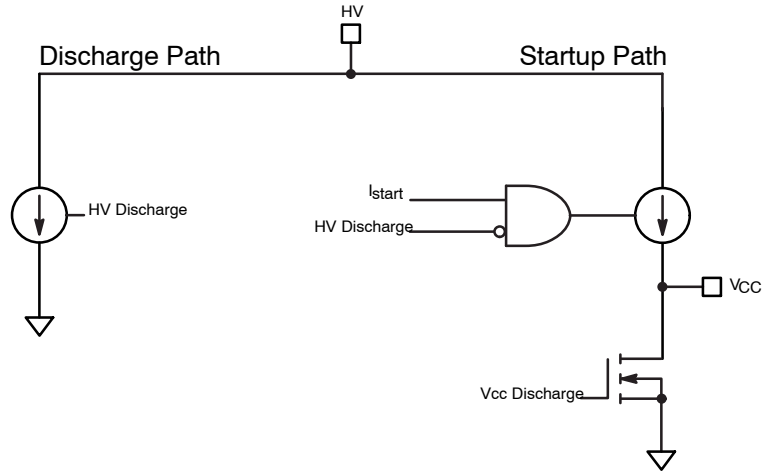

**Figure 23. Discharge Block Simplified Schematic**

# NCP1616

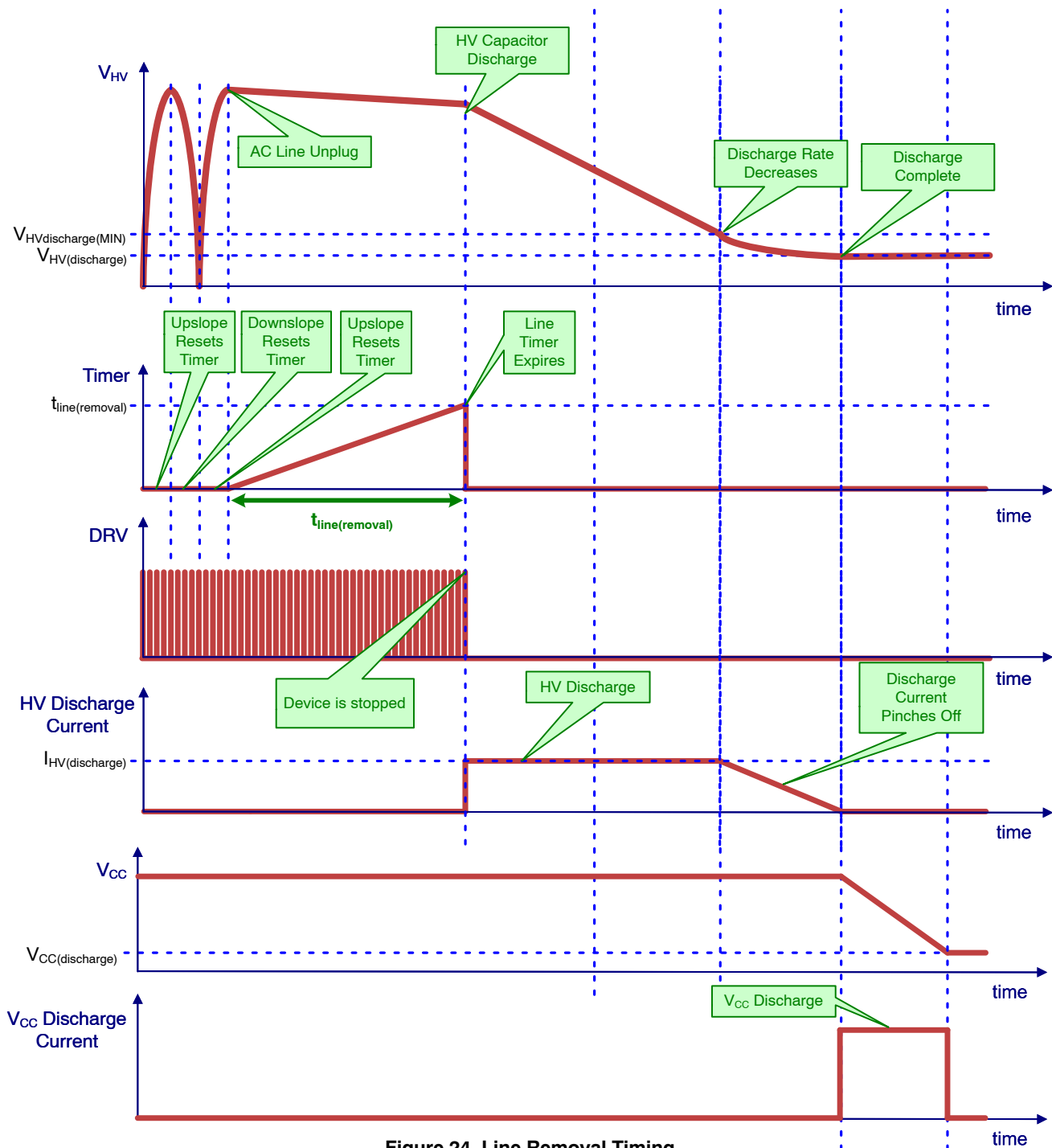

Figure 24. Line Removal Timing

## V<sub>CC</sub> DISCHARGE

If the downstream converter is latched due to a fault, it will require the supply voltage to be removed to reset the controller. Depending on the supply capacitor and current consumption, this may take a significant amount of time after the line voltage is removed. The NCP1616 uses the voltage at the HV pin to detect a line removal and discharge the V<sub>CC</sub> capacitor, effectively resetting the downstream converter.

Immediately following the line removal phase, V<sub>CC</sub> is discharged by a current sink, I<sub>CC(discharge)</sub>, typically 23 mA. The current sink is disabled and the device is allowed to restart once V<sub>CC</sub> falls down to V<sub>CC(discharge)</sub> (5 V maximum). This operation is shown in Figure 24.

## TEMPERATURE SHUTDOWN

An internal thermal shutdown circuit monitors the junction temperature of the IC. The controller is disabled if the junction temperature exceeds the thermal shutdown threshold, T<sub>SHDN</sub>, typically 150°C. A continuous V<sub>CC</sub> hiccup is initiated after a thermal shutdown fault is detected. The controller restarts at the next V<sub>CC(on)</sub> once the IC temperature drops below T<sub>SHDN</sub> by the thermal shutdown hysteresis, T<sub>SHDN(HYS)</sub>, typically 50°C.

The thermal shutdown fault is also cleared if V<sub>CC</sub> drops below V<sub>CC(reset)</sub>, or if a brownout/line removal fault is detected. A new power up sequence commences at the next V<sub>CC(on)</sub> once all the faults are removed.



TYPICAL CHARACTERISTICS

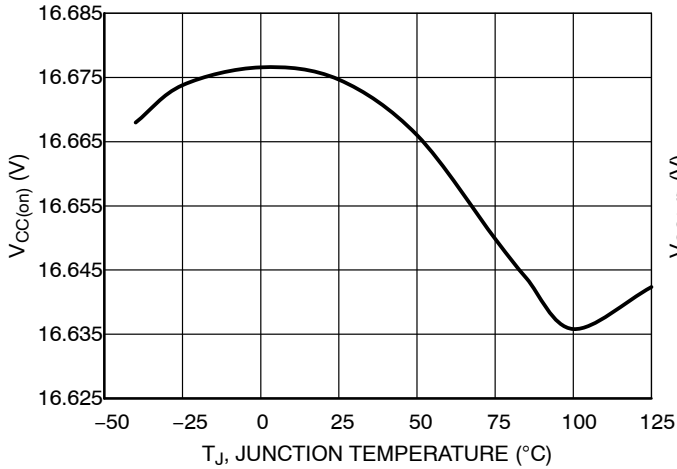

Figure 25. V<sub>CC(on)</sub> vs. Temperature

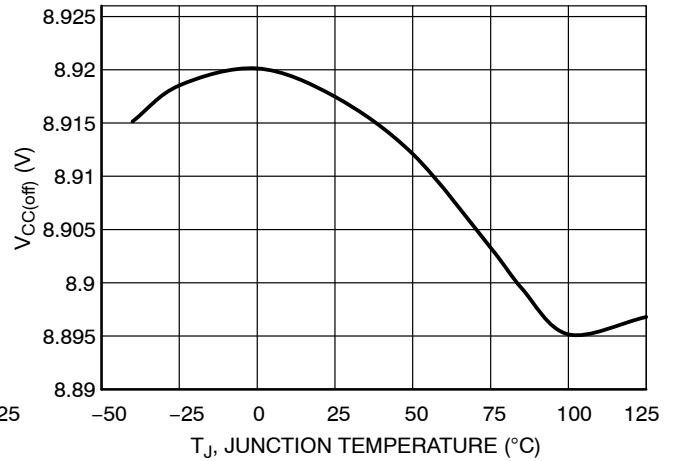

Figure 26. V<sub>CC(off)</sub> vs. Temperature

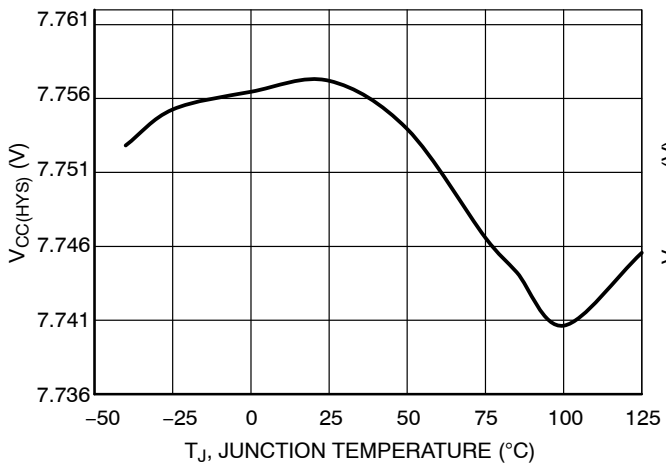

Figure 27. V<sub>CC(HYS)</sub> vs. Temperature

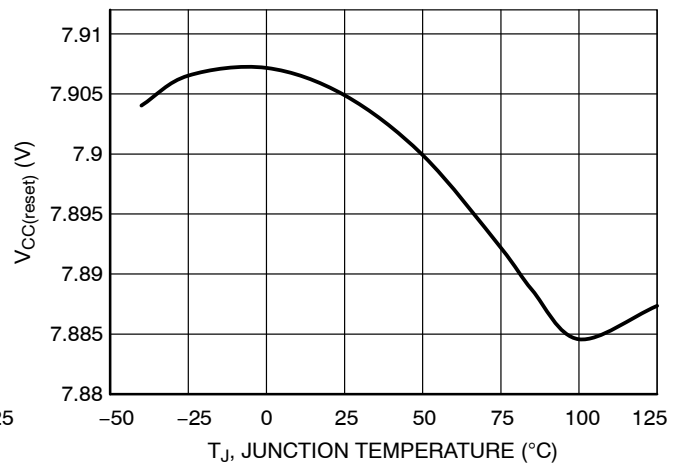

Figure 28. V<sub>CC(reset)</sub> vs. Temperature

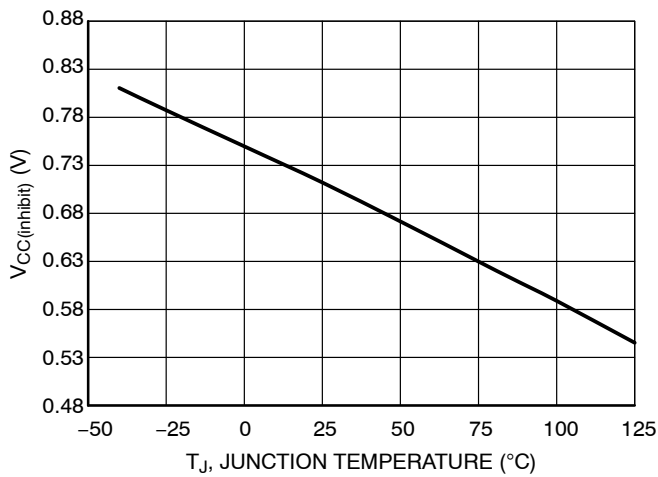

Figure 29. V<sub>CC(inhibit)</sub> vs. Temperature

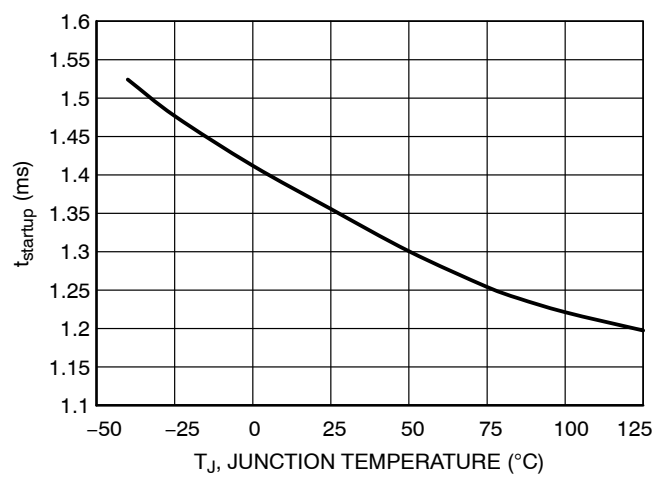

Figure 30. t<sub>startup</sub> vs. Temperature

# NCP1616

## TYPICAL CHARACTERISTICS

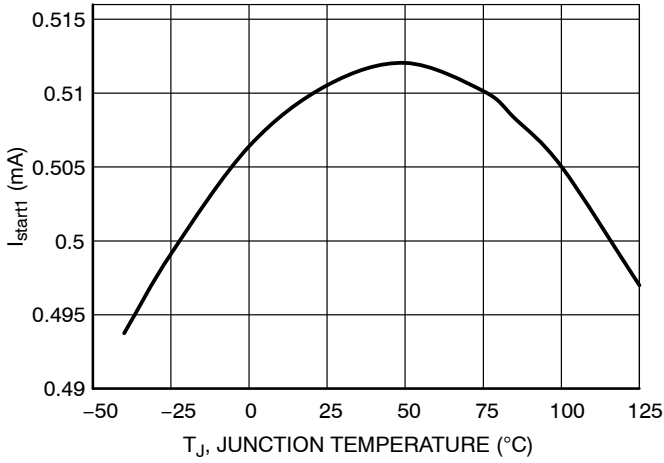

Figure 31. I<sub>start1</sub> vs. Temperature

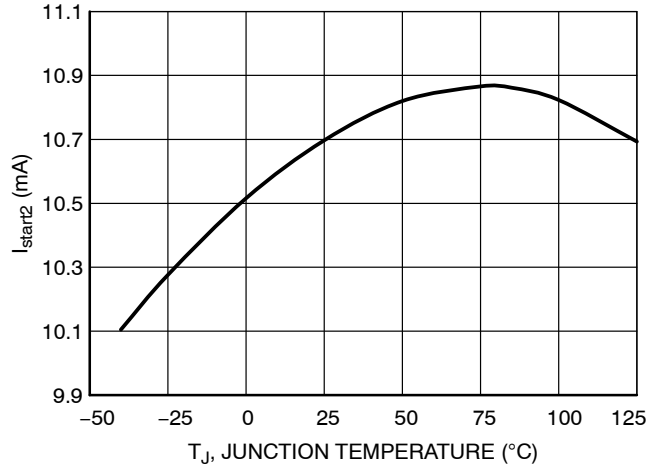

Figure 32. I<sub>start2</sub> vs. Temperature

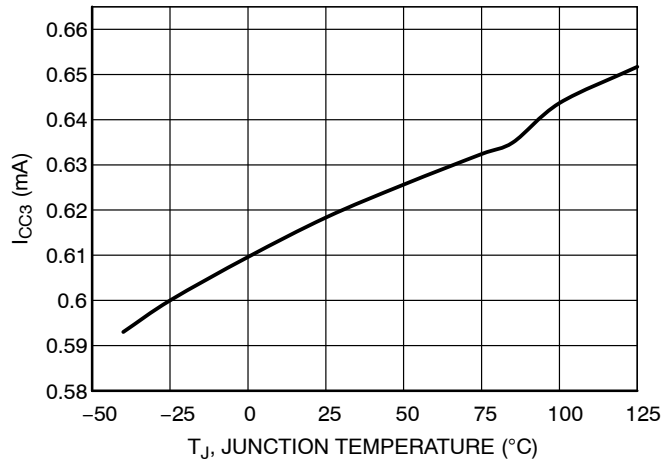

Figure 33. I<sub>CC3</sub> vs. Temperature

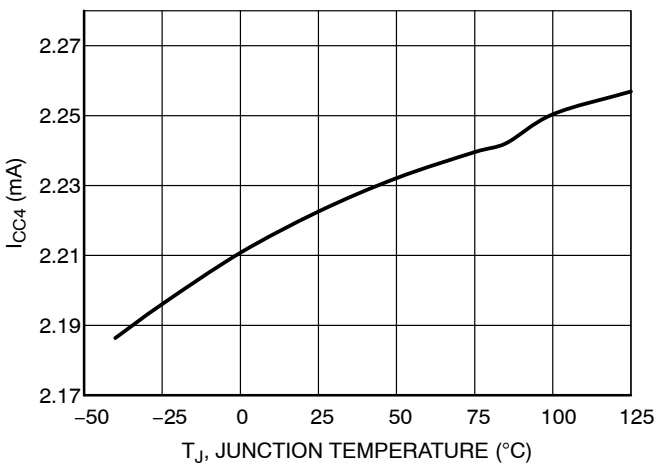

Figure 34. I<sub>CC4</sub> vs. Temperature

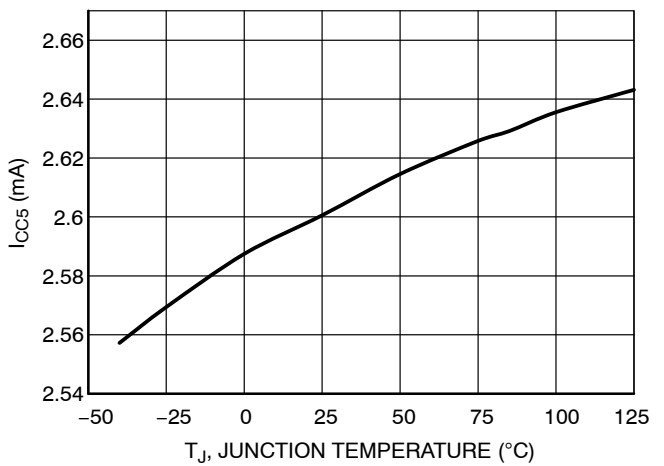

Figure 35. I<sub>CC5</sub> vs. Temperature

# NCP1616

## TYPICAL CHARACTERISTICS

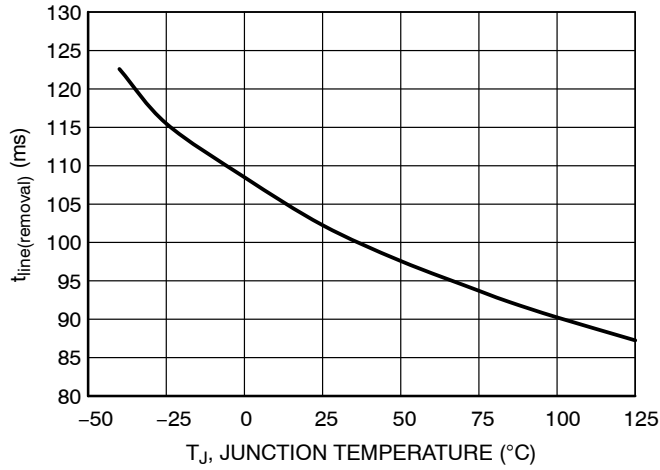

Figure 36.  $t_{line(removal)}$  vs. Temperature

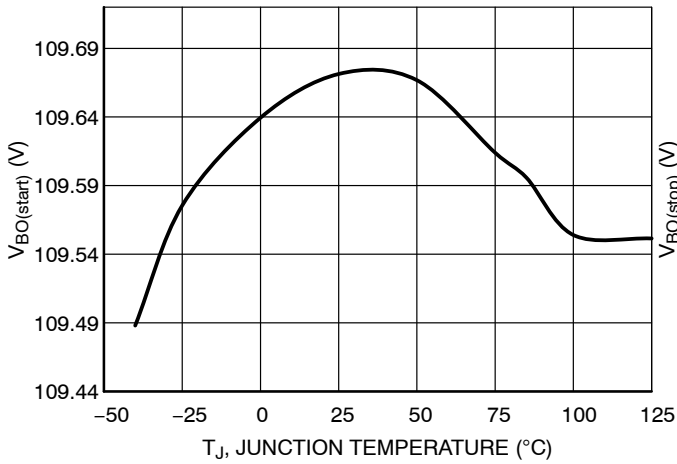

Figure 37.  $V_{BO(start)}$  vs. Temperature

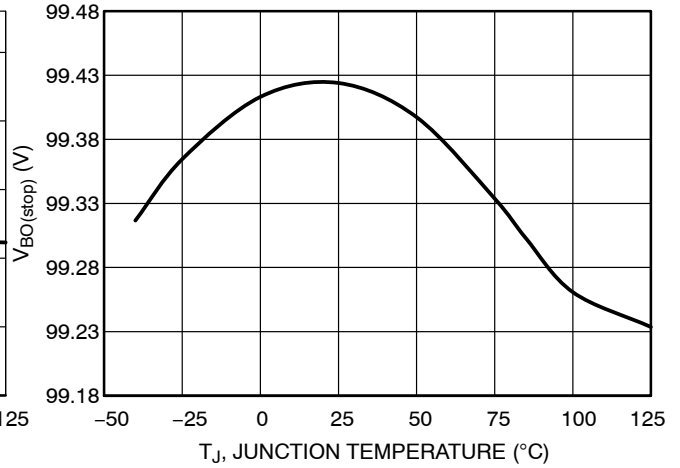

Figure 38.  $V_{BO(stop)}$  vs. Temperature

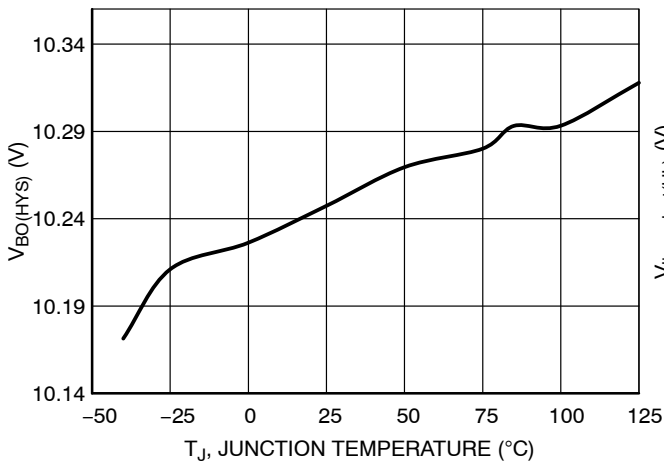

Figure 39.  $V_{BO(HYS)}$  vs. Temperature

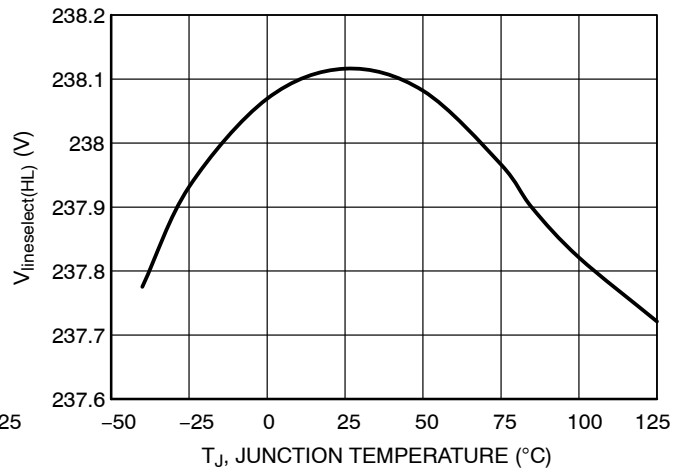

Figure 40.  $V_{lineselect(HL)}$  vs. Temperature

TYPICAL CHARACTERISTICS

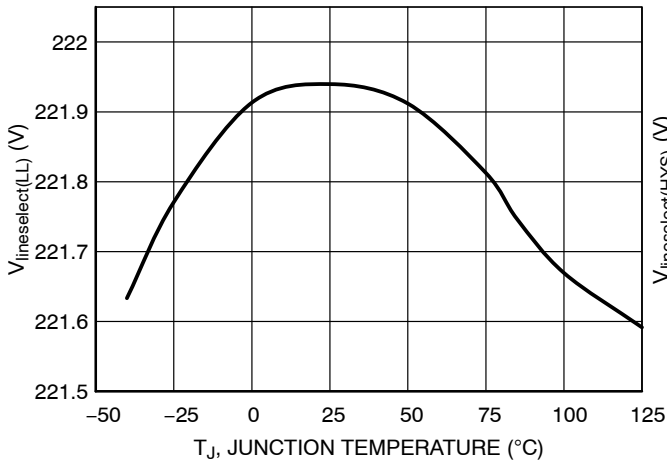

Figure 41.  $V_{lineselect(LL)}$  vs. Temperature

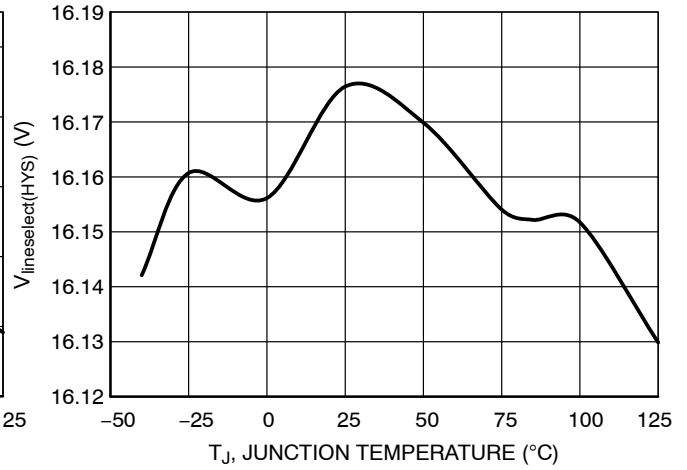

Figure 42.  $V_{lineselect(HYS)}$  vs. Temperature

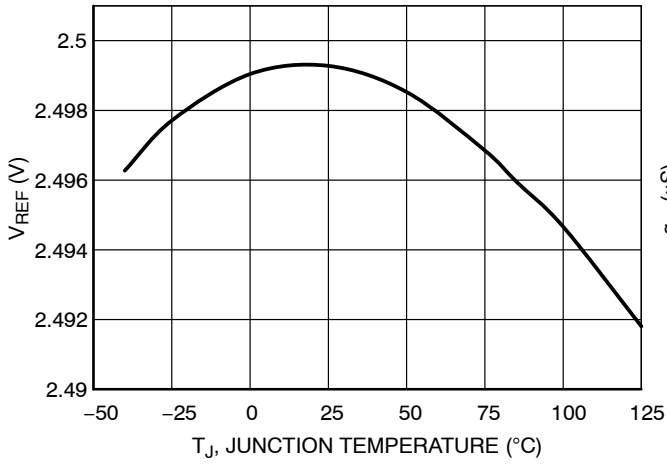

Figure 43.  $V_{REF}$  vs. Temperature

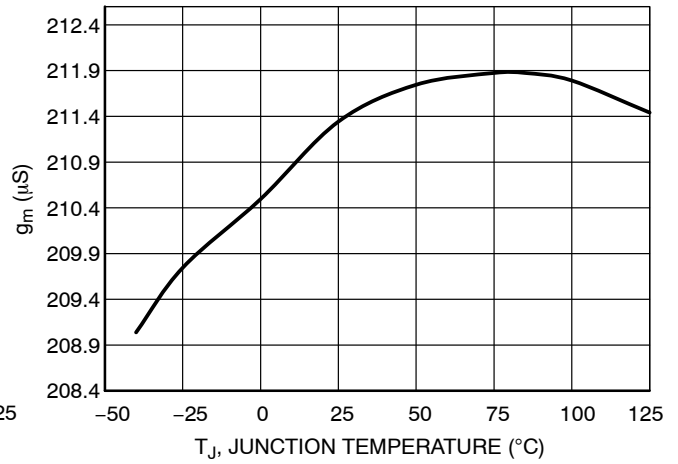

Figure 44.  $g_m$  vs. Temperature

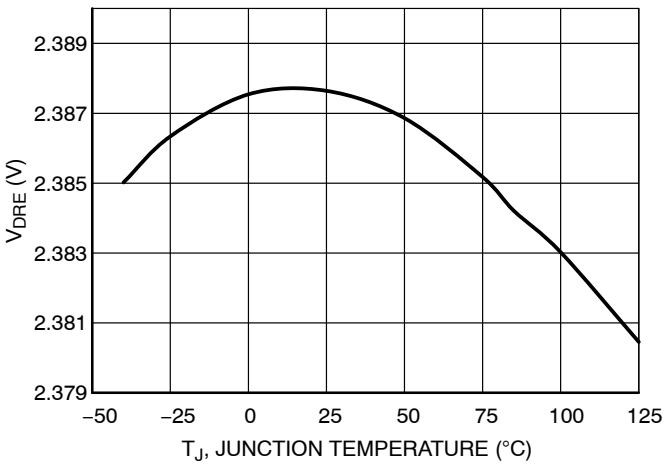

Figure 45.  $V_{DRE}$  vs. Temperature

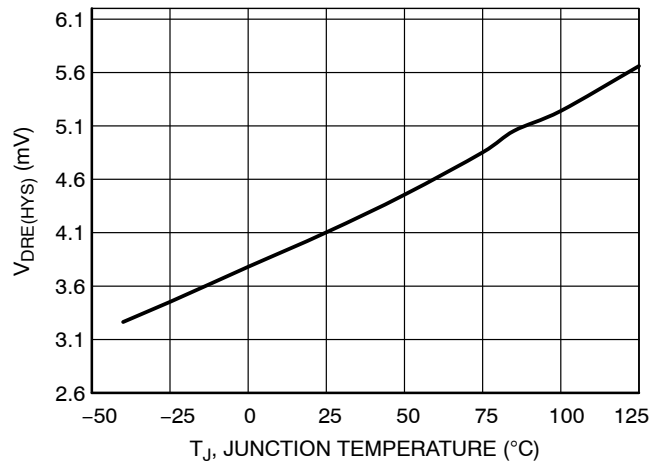

Figure 46.  $V_{DRE(HYS)}$  vs. Temperature

# NCP1616

## TYPICAL CHARACTERISTICS

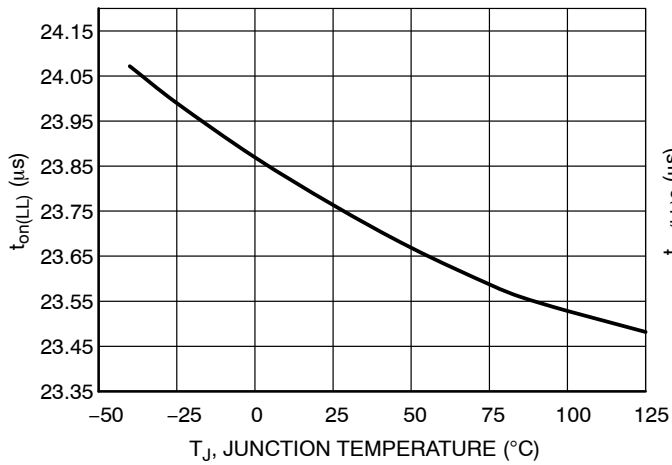

Figure 47.  $t_{on(LL)}$  vs. Temperature

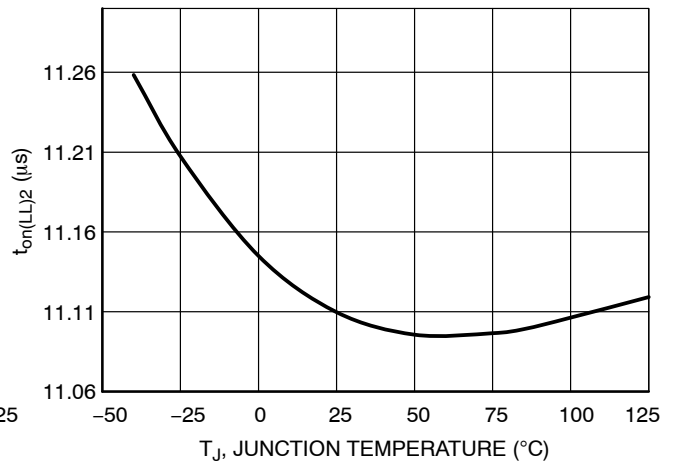

Figure 48.  $T_{on(LL)2}$  vs. Temperature

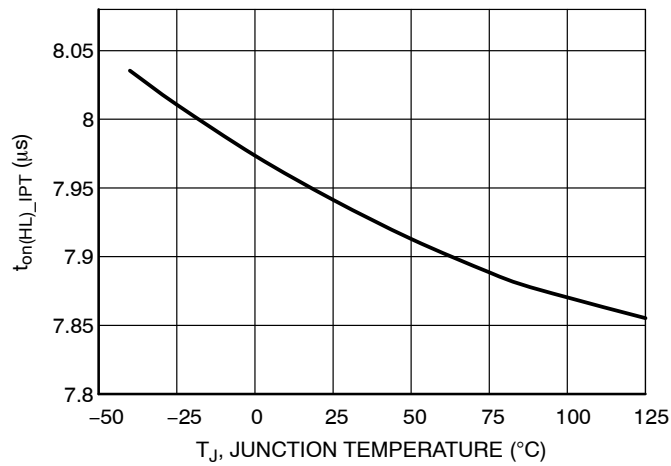

Figure 49.  $t_{on(HL)}$  vs. Temperature

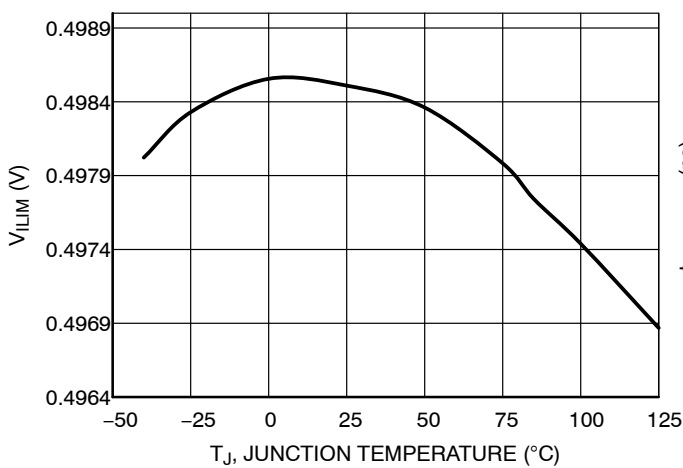

Figure 50.  $V_{ILIM}$  vs. Temperature

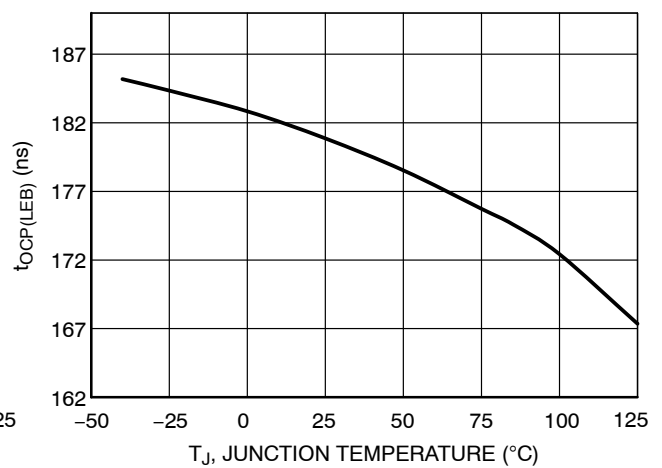

Figure 51.  $t_{OCP(LEB)}$  vs. Temperature

TYPICAL CHARACTERISTICS

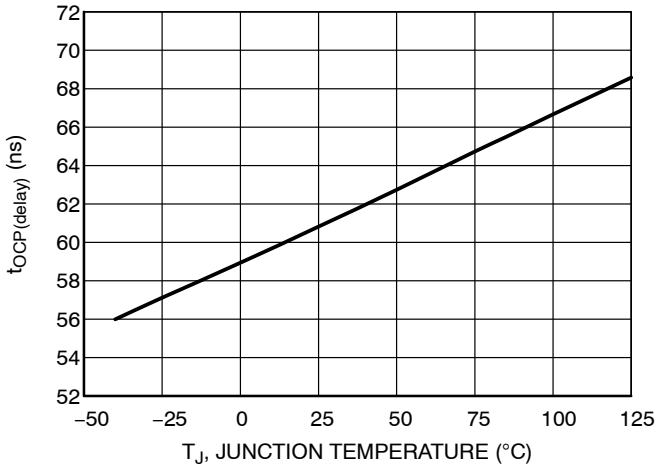

Figure 52.  $t_{OCP(delay)}$  vs. Temperature

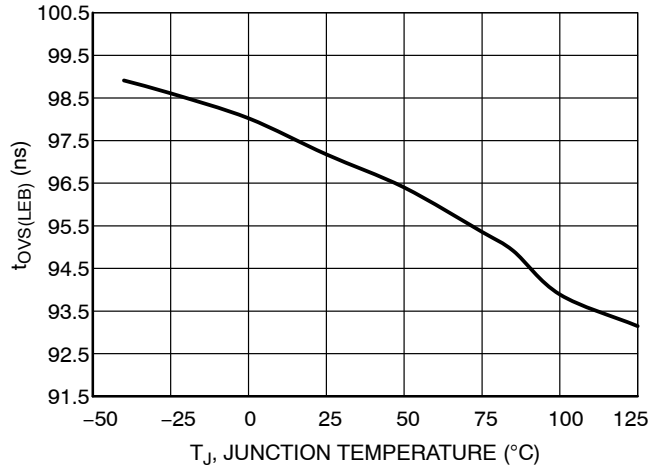

Figure 53.  $t_{OVS(LEB)}$  vs. Temperature

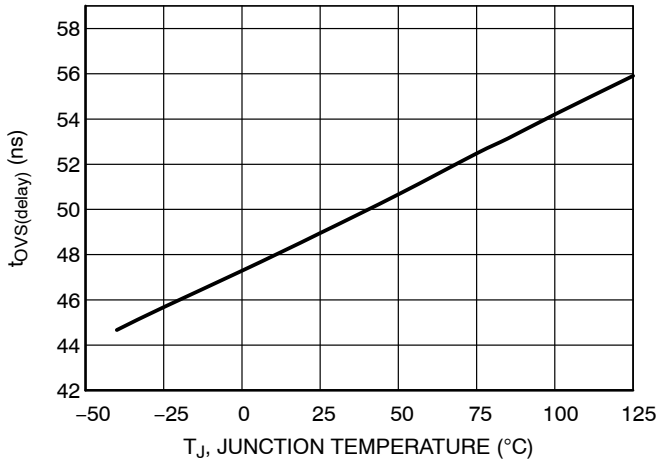

Figure 54.  $t_{OVS(delay)}$  vs. Temperature

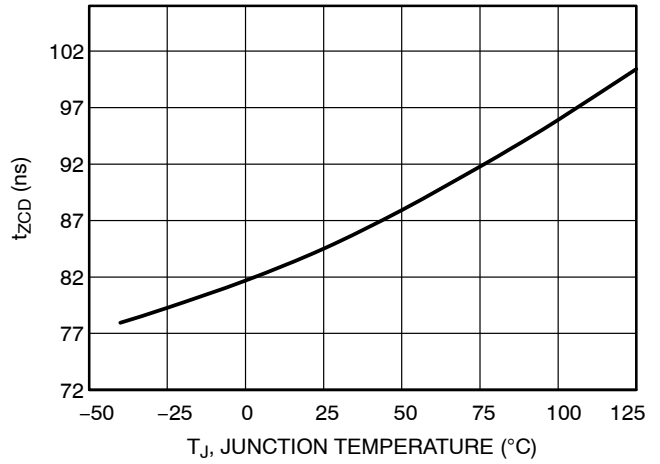

Figure 55.  $t_{ZCD}$  vs. Temperature

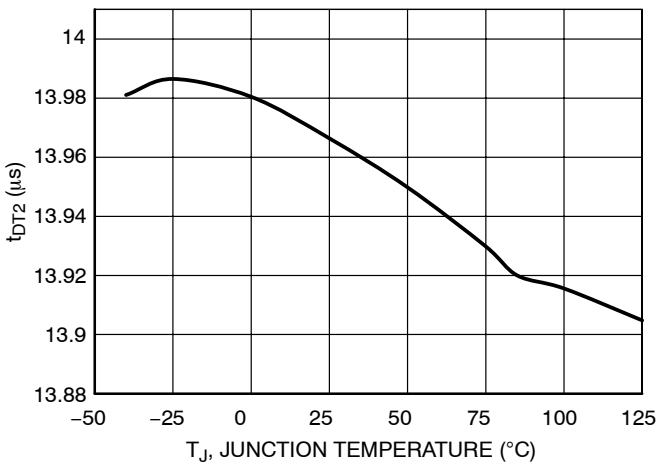

Figure 56.  $t_{DT2}$  vs. Temperature

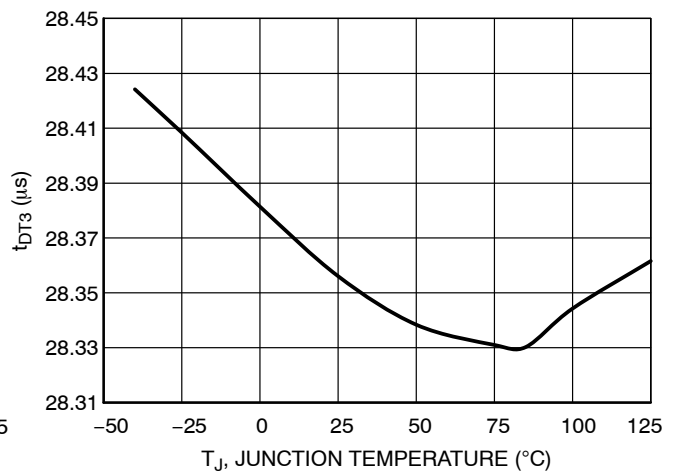

Figure 57.  $t_{DT3}$  vs. Temperature

TYPICAL CHARACTERISTICS

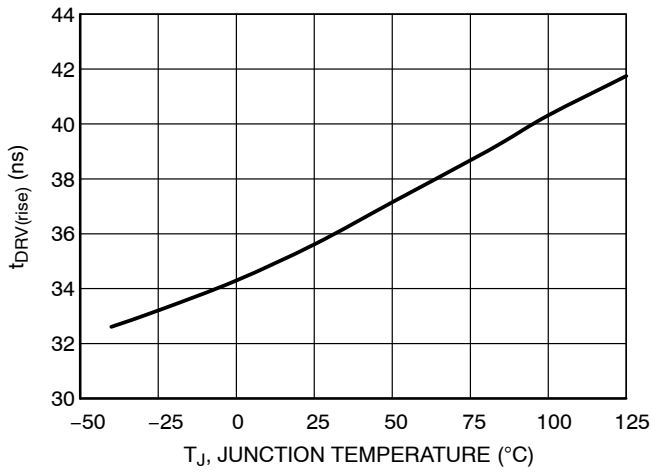

Figure 58.  $t_{DRV(rise)}$  vs. Temperature

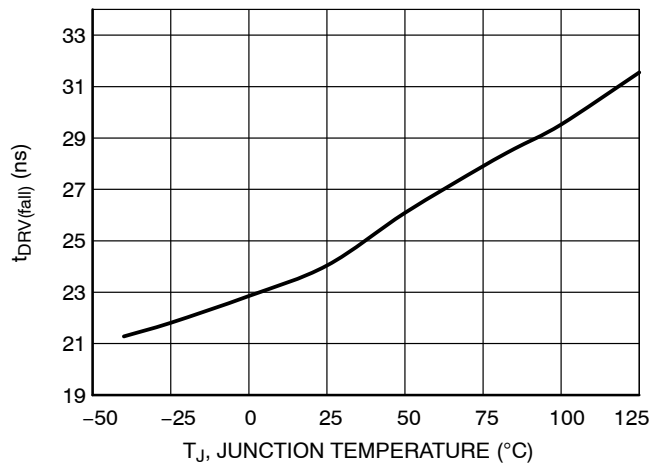

Figure 59.  $t_{DRV(fall)}$  vs. Temperature

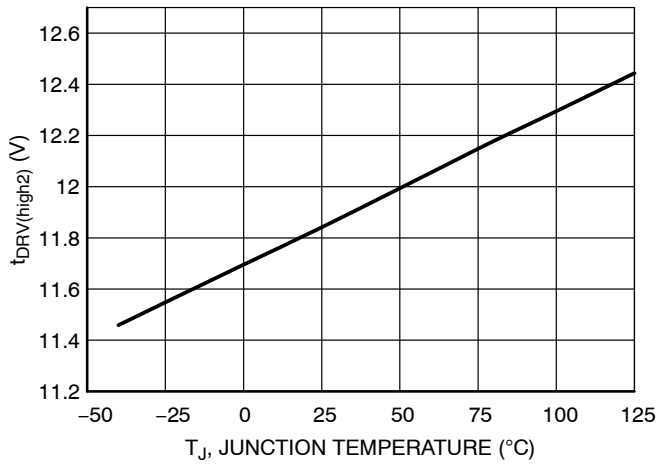

Figure 60.  $t_{DRV(high2)}$  vs. Temperature

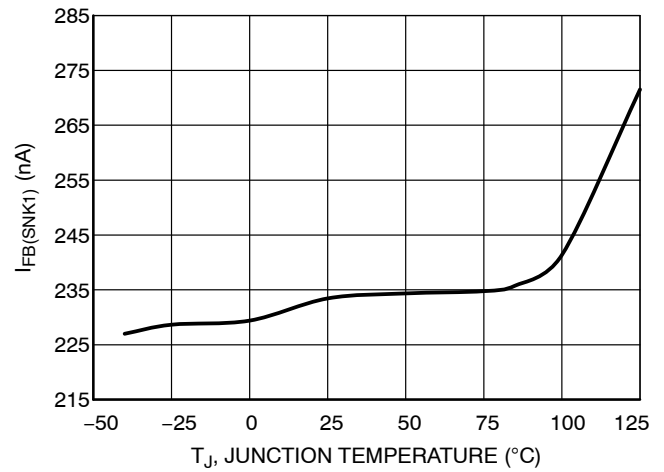

Figure 61.  $I_{FB(SNK1)}$  vs. Temperature

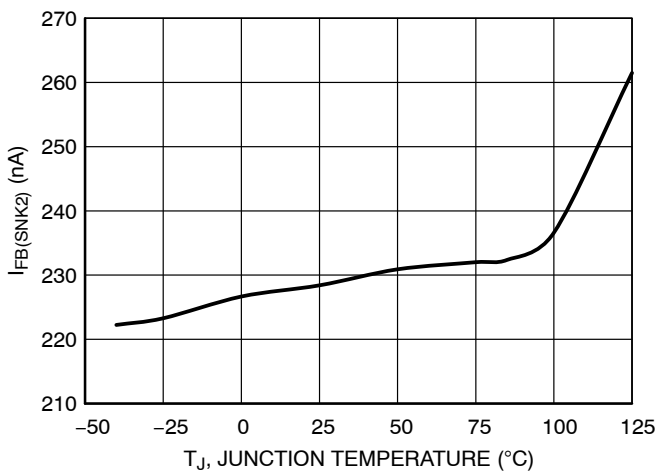

Figure 62.  $I_{FB(SNK2)}$  vs. Temperature

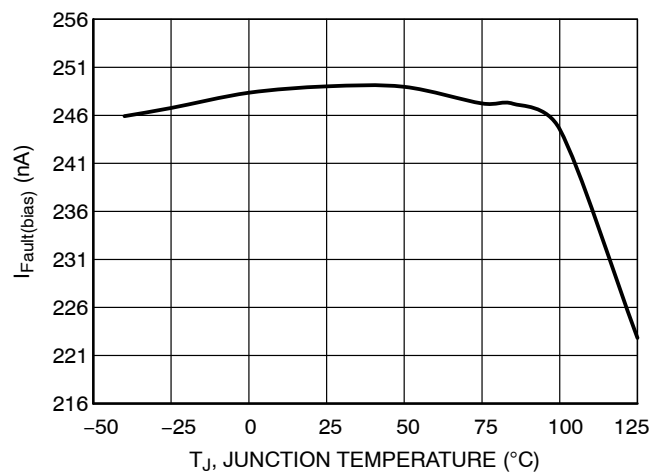

Figure 63.  $I_{Fault(bias)}$  vs. Temperature

# NCP1616

## TYPICAL CHARACTERISTICS

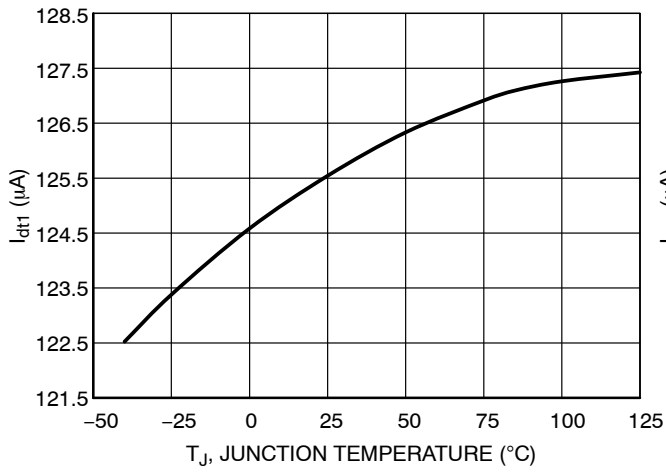

Figure 64. I<sub>dt1</sub> vs. Temperature

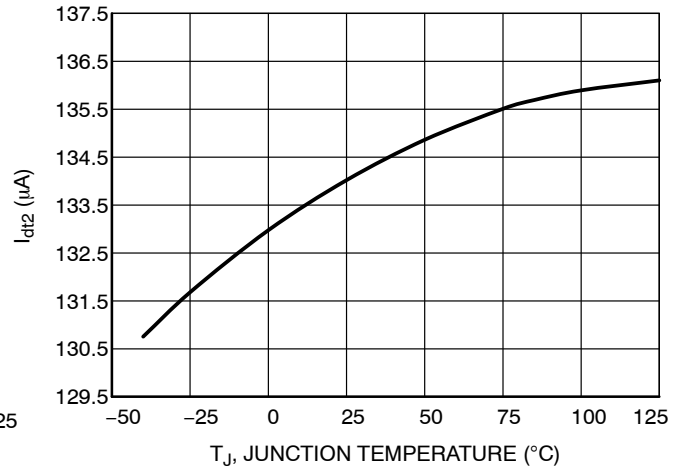

Figure 65. I<sub>dt2</sub> vs. Temperature

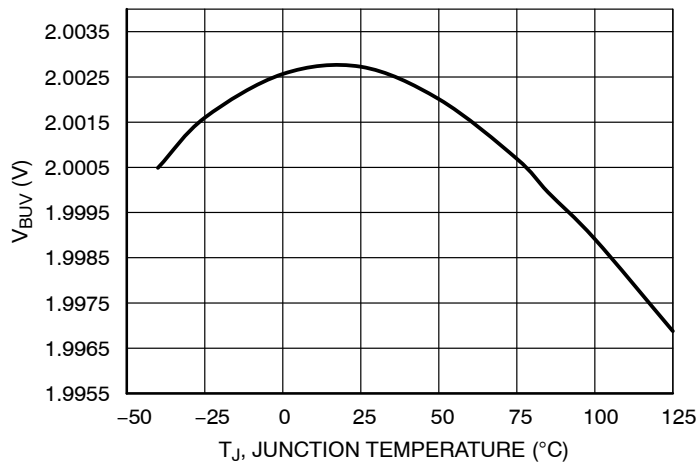

Figure 66. V<sub>BUV</sub> vs. Temperature

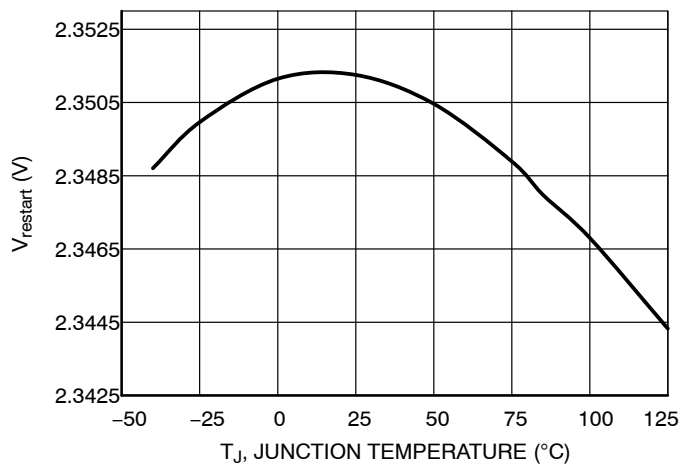

Figure 67. V<sub>restart</sub> vs. Temperature

# NCP1616

## TYPICAL CHARACTERISTICS

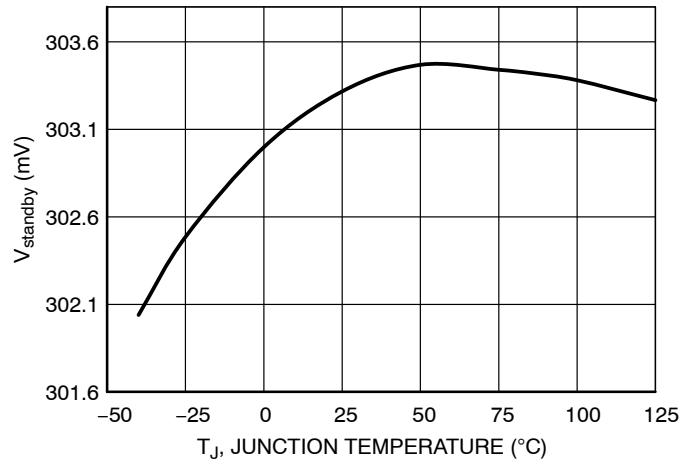

Figure 68.  $V_{\text{standby}}$  vs. Temperature



SCALE 1:1

SOIC-9 NB  
CASE 751BP  
ISSUE A

DATE 21 NOV 2011

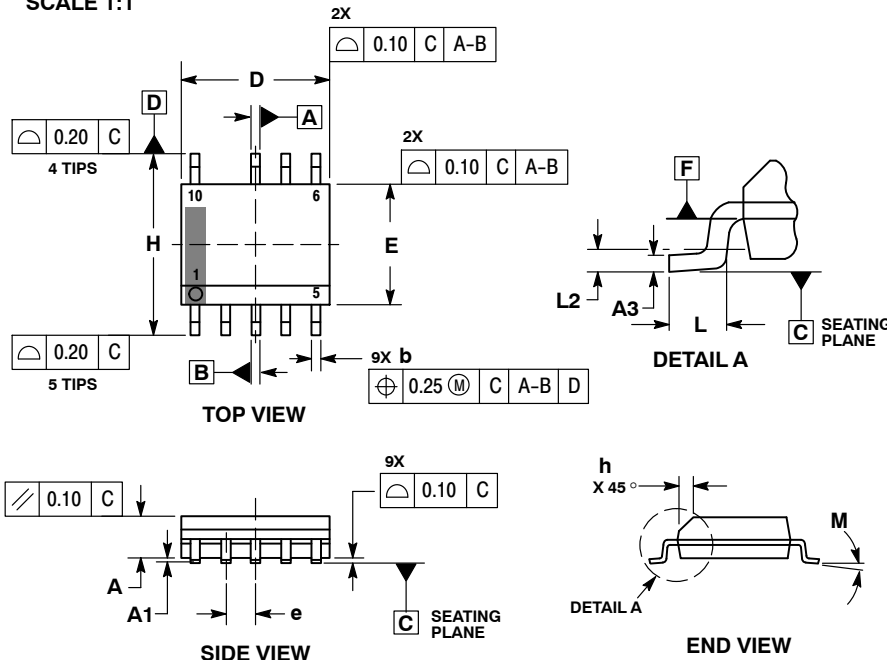

- NOTES:
1. DIMENSIONING AND TOLERANCING PER ASME Y14.5M, 1994.
  2. CONTROLLING DIMENSION: MILLIMETERS.
  3. DIMENSION b DOES NOT INCLUDE DAMBAR PROTRUSION. ALLOWABLE PROTRUSION SHALL BE 0.10mm TOTAL IN EXCESS OF 'b' AT MAXIMUM MATERIAL CONDITION.
  4. DIMENSIONS D AND E DO NOT INCLUDE MOLD FLASH, PROTRUSIONS, OR GATE BURRS. MOLD FLASH, PROTRUSIONS, OR GATE BURRS SHALL NOT EXCEED 0.15mm PER SIDE. DIMENSIONS D AND E ARE DETERMINED AT DATUM F.
  5. DIMENSIONS A AND B ARE TO BE DETERMINED AT DATUM F.
  6. A1 IS DEFINED AS THE VERTICAL DISTANCE FROM THE SEATING PLANE TO THE LOWEST POINT ON THE PACKAGE BODY.

DIM	MILLIMETERS	
	MIN	MAX
A	1.25	1.75
A1	0.10	0.25
A3	0.17	0.25
b	0.31	0.51
D	4.80	5.00
E	3.80	4.00
e	1.00 BSC	
H	5.80	6.20
h	0.37 REF	
L	0.40	1.27
L2	0.25 BSC	
M	0°	8°

RECOMMENDED  
SOLDERING FOOTPRINT\*

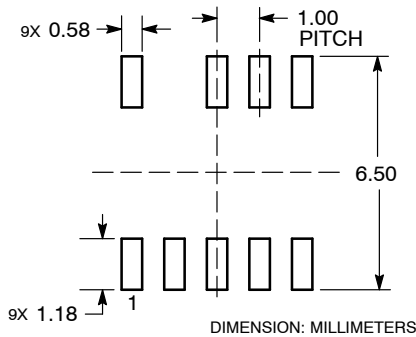

GENERIC  
MARKING DIAGRAM\*

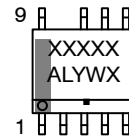

- XXXXX = Specific Device Code
- A = Assembly Location
- L = Wafer Lot
- Y = Year
- W = Work Week
- = Pb-Free Package

\*This information is generic. Please refer to device data sheet for actual part marking. Pb-Free indicator, "G", may or not be present.

\*For additional information on our Pb-Free strategy and soldering details, please download the onsemi Soldering and Mounting Techniques Reference Manual, SOLDERRM/D.

DOCUMENT NUMBER:	98AON52301E	Electronic versions are uncontrolled except when accessed directly from the Document Repository. Printed versions are uncontrolled except when stamped "CONTROLLED COPY" in red.
DESCRIPTION:	SOIC-9 NB	PAGE 1 OF 1

onsemi and ONSEMI are trademarks of Semiconductor Components Industries, LLC dba onsemi or its subsidiaries in the United States and/or other countries. onsemi reserves the right to make changes without further notice to any products herein. onsemi makes no warranty, representation or guarantee regarding the suitability of its products for any particular purpose, nor does onsemi assume any liability arising out of the application or use of any product or circuit, and specifically disclaims any and all liability, including without limitation special, consequential or incidental damages. onsemi does not convey any license under its patent rights nor the rights of others.

**onsemi**, **Onsemi**, and other names, marks, and brands are registered and/or common law trademarks of Semiconductor Components Industries, LLC dba "**onsemi**" or its affiliates and/or subsidiaries in the United States and/or other countries. **onsemi** owns the rights to a number of patents, trademarks, copyrights, trade secrets, and other intellectual property. A listing of **onsemi**'s product/patent coverage may be accessed at [www.onsemi.com/site/pdf/Patent-Marking.pdf](http://www.onsemi.com/site/pdf/Patent-Marking.pdf). **onsemi** reserves the right to make changes at any time to any products or information herein, without notice. The information herein is provided "as-is" and **onsemi** makes no warranty, representation or guarantee regarding the accuracy of the information, product features, availability, functionality, or suitability of its products for any particular purpose, nor does **onsemi** assume any liability arising out of the application or use of any product or circuit, and specifically disclaims any and all liability, including without limitation special, consequential or incidental damages. Buyer is responsible for its products and applications using **onsemi** products, including compliance with all laws, regulations and safety requirements or standards, regardless of any support or applications information provided by **onsemi**. "Typical" parameters which may be provided in **onsemi** data sheets and/or specifications can and do vary in different applications and actual performance may vary over time. All operating parameters, including "Typicals" must be validated for each customer application by customer's technical experts. **onsemi** does not convey any license under any of its intellectual property rights nor the rights of others. **onsemi** products are not designed, intended, or authorized for use as a critical component in life support systems or any FDA Class 3 medical devices or medical devices with a same or similar classification in a foreign jurisdiction or any devices intended for implantation in the human body. Should Buyer purchase or use **onsemi** products for any such unintended or unauthorized application, Buyer shall indemnify and hold **onsemi** and its officers, employees, subsidiaries, affiliates, and distributors harmless against all claims, costs, damages, and expenses, and reasonable attorney fees arising out of, directly or indirectly, any claim of personal injury or death associated with such unintended or unauthorized use, even if such claim alleges that **onsemi** was negligent regarding the design or manufacture of the part. **onsemi** is an Equal Opportunity/Affirmative Action Employer. This literature is subject to all applicable copyright laws and is not for resale in any manner.

## ADDITIONAL INFORMATION

### TECHNICAL PUBLICATIONS:

Technical Library: [www.onsemi.com/design/resources/technical-documentation](http://www.onsemi.com/design/resources/technical-documentation)  
onsemi Website: [www.onsemi.com](http://www.onsemi.com)

### ONLINE SUPPORT: [www.onsemi.com/support](http://www.onsemi.com/support)

For additional information, please contact your local Sales Representative at [www.onsemi.com/support/sales](http://www.onsemi.com/support/sales)