

Micropower Undervoltage Sensing Circuits

MC34164, MC33164, NCV33164

The MC34164 series are undervoltage sensing circuits specifically designed for use as reset controllers in portable microprocessor based systems where extended battery life is required. These devices offer the designer an economical solution for low voltage detection with a single external resistor. The MC34164 series features a bandgap reference, a comparator with precise thresholds and built-in hysteresis to prevent erratic reset operation, an open collector reset output capable of sinking in excess of 6.0 mA, and guaranteed operation down to 1.0 V input with extremely low standby current. The MC devices are packaged in 3-pin TO-92 (TO-226AA), micro size TSOP-5, 8-pin SOIC-8 and Micro8 surface mount packages. The NCV device is packaged in SOIC-8.

Applications include direct monitoring of the 3.0 V or 5.0 V MPU/logic power supply used in appliance, automotive, consumer, and industrial equipment.

Features

- Temperature Compensated Reference
- Monitors 3.0 V (MC34164-3) or 5.0 V (MC34164-5) Power Supplies
- Precise Comparator Thresholds Guaranteed Over Temperature
- Comparator Hysteresis Prevents Erratic Reset
- Reset Output Capable of Sinking in Excess of 6.0 mA
- Internal Clamp Diode for Discharging Delay Capacitor
- Guaranteed Reset Operation With 1.0 V Input
- Extremely Low Standby Current: As Low as 9.0 μ A
- Economical TO-92 (TO-226AA), TSOP-5, SOIC-8 and Micro8 Surface Mount Packages
- NCV Prefix for Automotive and Other Applications Requiring Site and Control Changes
- These Devices are Pb-Free and are RoHS Compliant

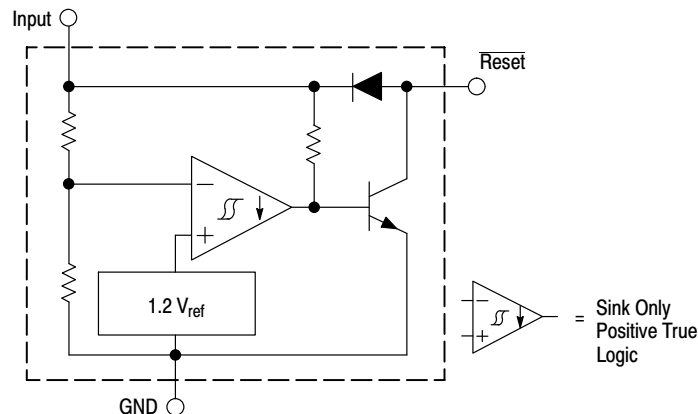
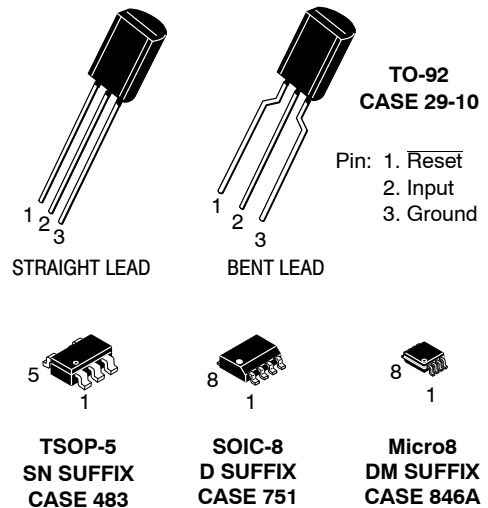
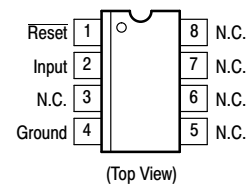

Figure 1. Representative Block Diagram

This device contains 28 active transistors.



PIN CONNECTIONS



TSOP-5

- Pin 1. Ground
Pin 2. Input
Pin 3. Reset
Pin 4. NC
Pin 5. NC

TO-92

- Pin 1. $\overline{\text{Reset}}$
Pin 2. Input
Pin 3. Ground

ORDERING INFORMATION

See detailed ordering and shipping information on page 7 of this data sheet.

NOTE: Some of the devices on this data sheet have been **DISCONTINUED**. Please refer to the table on page 7.

DEVICE MARKING INFORMATION

See general marking information in the device marking section on page 8 of this data sheet.

MC34164, MC33164, NCV33164

MAXIMUM RATINGS

| Symbol | Rating | Value | Unit |
|--------------------------|---|--------------------------|--------------------------|
| V_{in} | Power Input Supply Voltage | -1.0 to 12 | V |
| V_O | $\overline{\text{Reset}}$ Output Voltage | -1.0 to 12 | V |
| I_{Sink} | $\overline{\text{Reset}}$ Output Sink Current | Internally Limited | mA |
| IF | Clamp Diode Forward Current, Reset to Input Pin (Note 1) | 100 | mA |
| P_D $R_{\theta JA}$ | Power Dissipation and Thermal Characteristics P Suffix, Plastic Package Maximum Power Dissipation @ $T_A = 25^\circ\text{C}$ Thermal Resistance, Junction-to-Air | 700 178 | mW $^\circ\text{C/W}$ |
| P_D $R_{\theta JA}$ | D Suffix, Plastic Package Maximum Power Dissipation @ $T_A = 25^\circ\text{C}$ Thermal Resistance, Junction-to-Air | 700 178 | mW $^\circ\text{C/W}$ |
| P_D $R_{\theta JA}$ | DM Suffix, Plastic Package Maximum Power Dissipation @ $T_A = 25^\circ\text{C}$ Thermal Resistance, Junction-to-Air | 520 240 | mW $^\circ\text{C/W}$ |
| T_J | Operating Junction Temperature | +150 | $^\circ\text{C}$ |
| T_A | Operating Ambient Temperature Range MC34164 Series MC33164 Series, NCV33164 | 0 to +70 - 40 to +125 | $^\circ\text{C}$ |
| T_{stg} | Storage Temperature Range | - 65 to +150 | $^\circ\text{C}$ |
| ESD | Electrostatic Discharge Sensitivity (ESD) Human Body Model (HBM) Machine Model (MM) | 4000 200 | V |

Stresses exceeding those listed in the Maximum Ratings table may damage the device. If any of these limits are exceeded, device functionality should not be assumed, damage may occur and reliability may be affected.

MC34164-3, MC33164-3 SERIES, NCV33164-3

ELECTRICAL CHARACTERISTICS (For typical values $T_A = 25^\circ\text{C}$, for min/max values T_A is the operating ambient temperature range that applies [Notes 2 & 3], unless otherwise noted.)

| Symbol | Characteristic | Min | Typ | Max | Unit |
|--------|----------------|-----|-----|-----|------|
|--------|----------------|-----|-----|-----|------|

COMPARATOR

| | | | | | |
|----------|---|------|------|------|---|
| V_{IH} | Threshold Voltage High State Output (V_{in} Increasing) | 2.55 | 2.71 | 2.80 | V |
| V_{IL} | Low State Output (V_{in} Decreasing) | 2.55 | 2.65 | 2.80 | |
| V_H | Hysteresis ($I_{\text{Sink}} = 100\ \mu\text{A}$) | 0.03 | 0.06 | - | |

RESET OUTPUT

| | | | | | |
|---------------------------|---|--------|--------------|------------|---------------|
| V_{OL} | Output Sink Saturation ($V_{in} = 2.4\ \text{V}$, $I_{\text{Sink}} = 1.0\ \text{mA}$) ($V_{in} = 1.0\ \text{V}$, $I_{\text{Sink}} = 0.25\ \text{mA}$) | - - | 0.14 0.1 | 0.4 0.3 | V |
| I_{Sink} | Output Sink Current (V_{in} , $\overline{\text{Reset}} = 2.4\ \text{V}$) | 6.0 | 12 | 30 | mA |
| $I_{\overline{R}}$ (leak) | Output Off-State Leakage (V_{in} , $\overline{\text{Reset}} = 3.0\ \text{V}$) (V_{in} , $\overline{\text{Reset}} = 10\ \text{V}$) | - - | 0.02 0.02 | 0.5 1.0 | μA |
| V_F | Clamp Diode Forward Voltage, Reset to Input Pin ($I_F = 5.0\ \text{mA}$) | 0.6 | 0.9 | 1.2 | V |

TOTAL DEVICE

| | | | | | |
|----------|---|-----------|-----------|----------|---------------|
| V_{in} | Operating Input Voltage Range | 1.0 to 10 | - | - | V |
| I_{in} | Quiescent Input Current $V_{in} = 3.0\ \text{V}$ $V_{in} = 6.0\ \text{V}$ | - - | 9.0 24 | 15 40 | μA |

- Maximum package power dissipation limits must be observed.
- Low duty cycle pulse techniques are used during test to maintain junction temperature as close to ambient as possible.
- $T_{\text{low}} = 0^\circ\text{C}$ for MC34164
 $T_{\text{high}} = +70^\circ\text{C}$ for MC34164
 $= -40^\circ\text{C}$ for MC33164, NCV33164
 $= +125^\circ\text{C}$ for MC33164, NCV33164

MC34164, MC33164, NCV33164

MC34164-5, MC33164-5 SERIES, NCV33164-5

ELECTRICAL CHARACTERISTICS (For typical values $T_A = 25\text{ }^\circ\text{C}$, for min/max values T_A is the operating ambient temperature range that applies [Notes 5 & 6], unless otherwise noted.)

| Characteristic | Symbol | Min | Typ | Max | Unit |
|----------------|--------|-----|-----|-----|------|
|----------------|--------|-----|-----|-----|------|

COMPARATOR

| | | | | | |
|--|----------|------|------|------|---|
| Threshold Voltage | | | | | V |
| High State Output (V_{in} Increasing) | V_{IH} | 4.15 | 4.33 | 4.45 | |
| Low State Output (V_{in} Decreasing) | V_{IL} | 4.15 | 4.27 | 4.45 | |
| Hysteresis ($I_{Sink} = 100\text{ }\mu\text{A}$) | V_H | 0.02 | 0.09 | - | |

RESET OUTPUT

| | | | | | |
|---|--------------------|-----|--------------|------------|---------------|
| Output Sink Saturation ($V_{in} = 4.0\text{ V}$, $I_{Sink} = 1.0\text{ mA}$) ($V_{in} = 1.0\text{ V}$, $I_{Sink} = 0.25\text{ mA}$) | V_{OL} | - | 0.14 0.1 | 0.4 0.3 | V |
| Output Sink Current (V_{in} , $\overline{\text{Reset}} = 4.0\text{ V}$) | I_{Sink} | 7.0 | 20 | 50 | mA |
| Output Off-State Leakage (V_{in} , $\overline{\text{Reset}} = 5.0\text{ V}$) (V_{in} , $\overline{\text{Reset}} = 10\text{ V}$) | $I_R(\text{leak})$ | - | 0.02 0.02 | 0.5 2.0 | μA |
| Clamp Diode Forward Voltage, Reset to Input Pin ($I_F = 5.0\text{ mA}$) | V_F | 0.6 | 0.9 | 1.2 | V |

TOTAL DEVICE

| | | | | | |
|--|----------|-----------|----------|----------|---------------|
| Operating Input Voltage Range | V_{in} | 1.0 to 10 | - | - | V |
| Quiescent Input Current $V_{in} = 5.0\text{ V}$ $V_{in} = 10\text{ V}$ | I_{in} | - | 12 32 | 20 50 | μA |

Product parametric performance is indicated in the Electrical Characteristics for the listed test conditions, unless otherwise noted. Product performance may not be indicated by the Electrical Characteristics if operated under different conditions.

- Maximum package power dissipation limits must be observed.
- Low duty cycle pulse techniques are used during test to maintain junction temperature as close to ambient as possible.
- $T_{low} = 0\text{ }^\circ\text{C}$ for MC34164 $T_{high} = +70\text{ }^\circ\text{C}$ for MC34164
 $= -40\text{ }^\circ\text{C}$ for MC33164, NCV33164 $= +125\text{ }^\circ\text{C}$ for MC33164, NCV33164
- NCV prefix is for automotive and other applications requiring site and change control.

TYPICAL CHARACTERISTICS

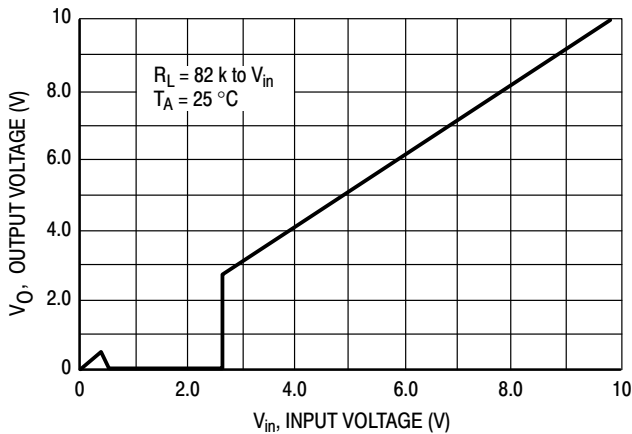

Figure 2. MC3X164-3 $\overline{\text{Reset}}$ Output Voltage versus Input Voltage

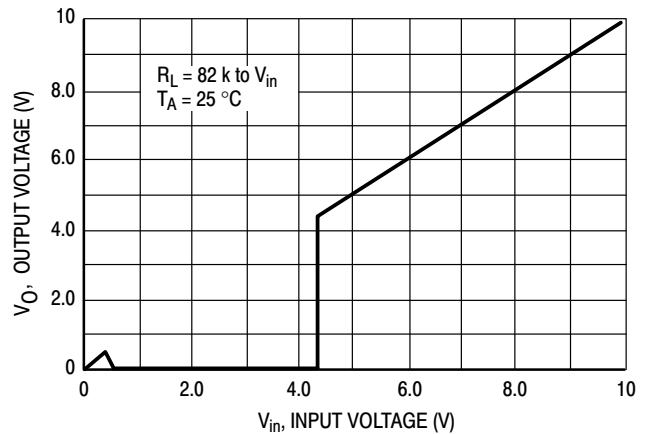

Figure 3. MC3X164-5 $\overline{\text{Reset}}$ Output Voltage versus Input Voltage

TYPICAL CHARACTERISTICS (continued)

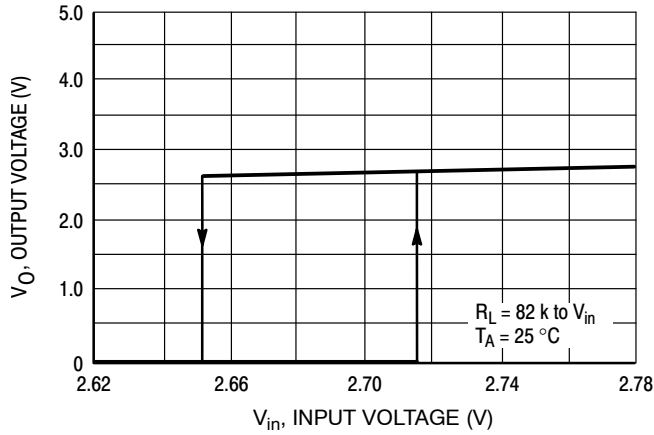

Figure 4. MC3X164-3 Reset Output Voltage versus Input Voltage

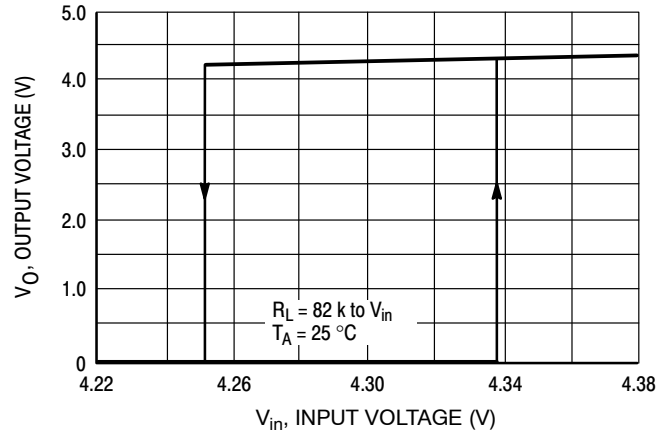

Figure 5. MC3X164-5 Reset Output Voltage versus Input Voltage

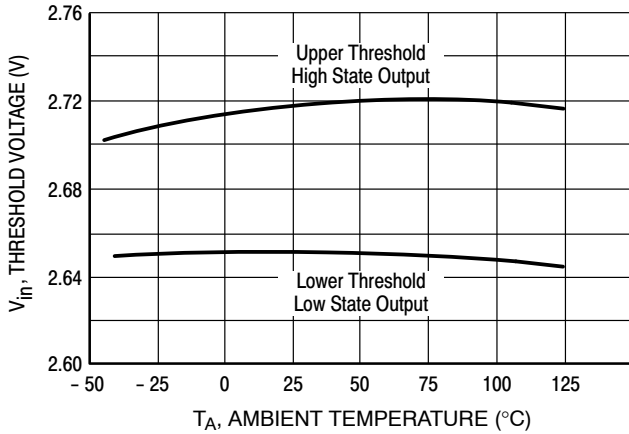

Figure 6. MC3X164-3 Comparator Threshold Voltage versus Temperature

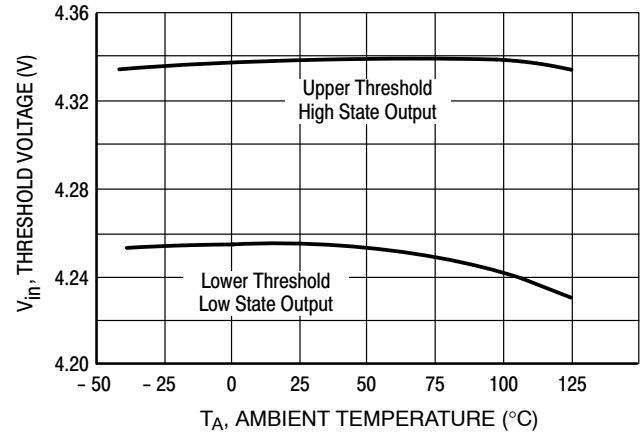

Figure 7. MC3X164-5 Comparator Threshold Voltage versus Temperature

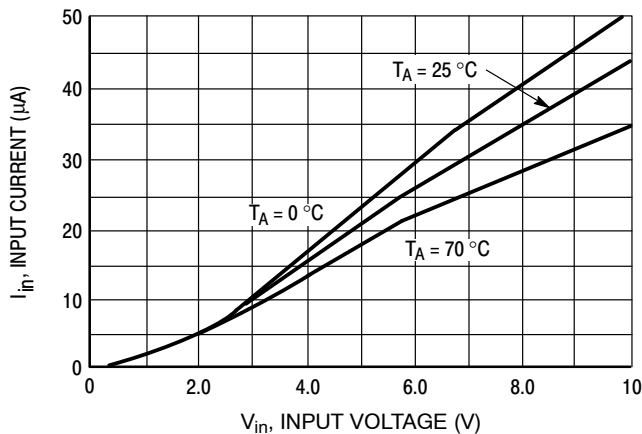

Figure 8. MC3X164-3 Input Current versus Input Voltage

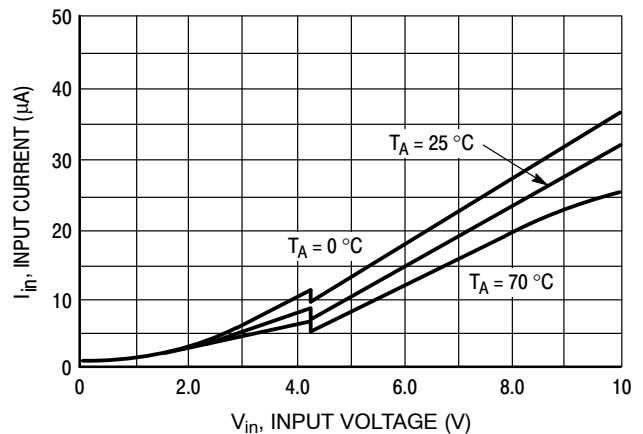

Figure 9. MC3X164-5 Input Current versus Input Voltage

TYPICAL CHARACTERISTICS (continued)

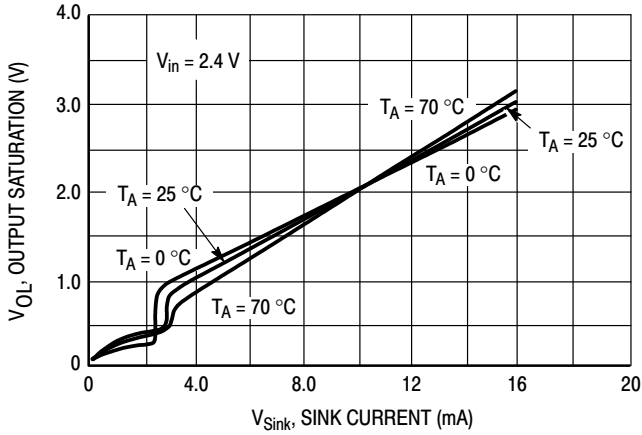

Figure 10. MC3X164-3 $\overline{\text{Reset}}$ Output Saturation versus Sink Current

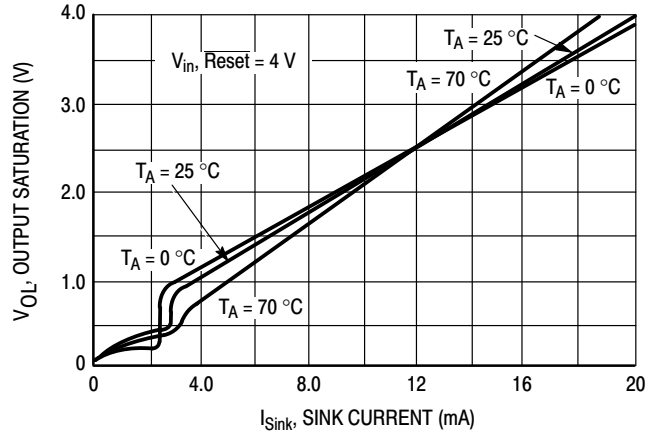

Figure 11. MC3X164-5 $\overline{\text{Reset}}$ Output Saturation versus Sink Current

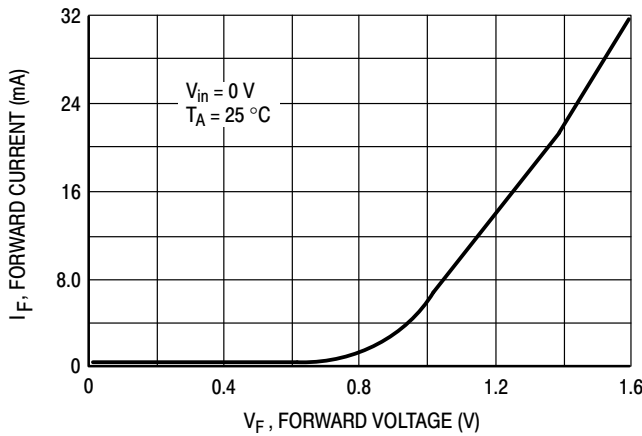

Figure 12. Clamp Diode Forward Current versus Voltage

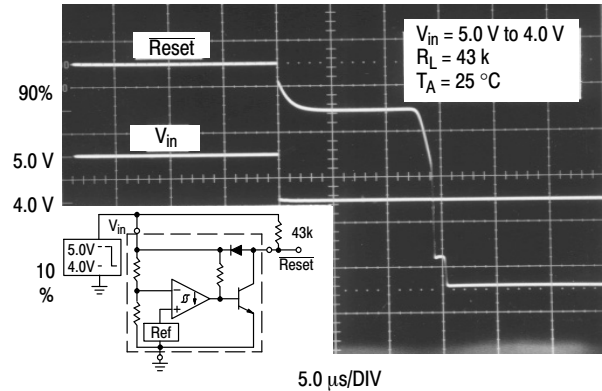
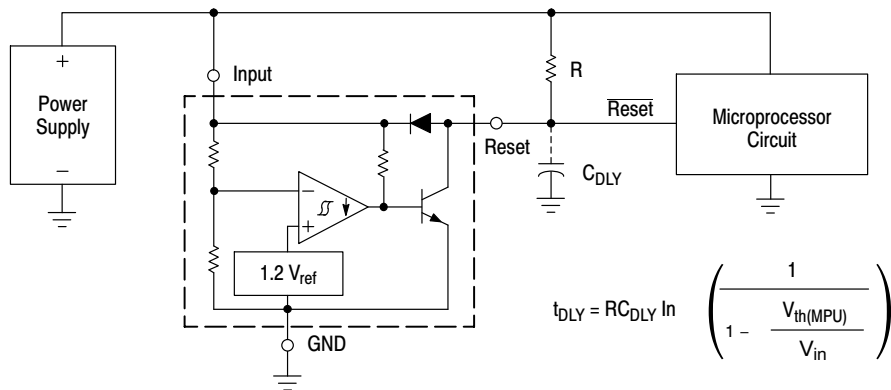

Figure 13. $\overline{\text{Reset}}$ Delay Time (MC3X164-5 Shown)



A time delayed reset can be accomplished with the addition of C_{DLY} . For systems with extremely fast power supply rise times (< 500 ns) it is recommended that the RC_{DLY} time constant be greater than $5.0 \mu\text{s}$. $V_{th(MPU)}$ is the microprocessor reset input threshold.

Figure 14. Low Voltage Microprocessor Reset

MC34164, MC33164, NCV33164

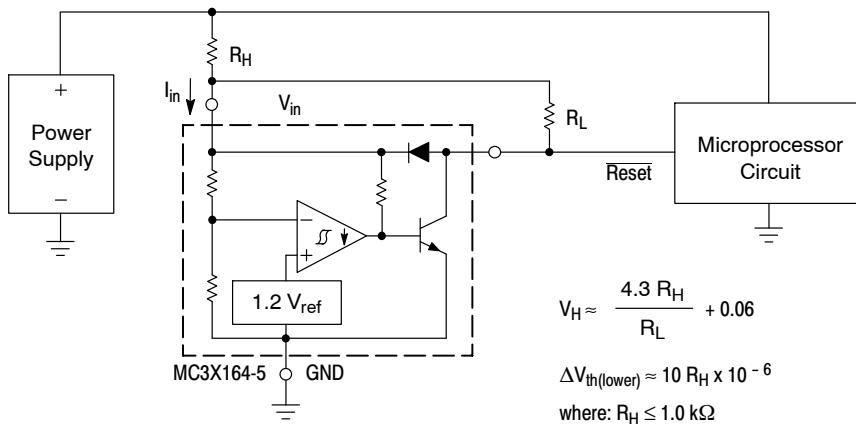

$$V_H \approx \frac{4.3 R_H}{R_L} + 0.06$$

$$\Delta V_{th(lower)} \approx 10 R_H \times 10^{-6}$$

where: $R_H \leq 1.0 \text{ k}\Omega$
 $43 \text{ k}\Omega \geq R_L \geq 4.3 \text{ k}\Omega$

| Test Data | | | |
|------------|----------------------|--------------------|---------------------|
| V_H (mV) | ΔV_{th} (mV) | R_H (Ω) | R_L (k Ω) |
| 60 | 0 | 0 | 43 |
| 103 | 1.0 | 100 | 10 |
| 123 | 1.0 | 100 | 6.8 |
| 160 | 1.0 | 100 | 4.3 |
| 155 | 2.2 | 220 | 10 |
| 199 | 2.2 | 220 | 6.8 |
| 280 | 2.2 | 220 | 4.3 |
| 262 | 4.7 | 470 | 10 |
| 306 | 4.7 | 470 | 8.2 |
| 357 | 4.7 | 470 | 6.8 |
| 421 | 4.7 | 470 | 5.6 |
| 530 | 4.7 | 470 | 4.3 |

Comparator hysteresis can be increased with the addition of resistor R_H . The hysteresis equation has been simplified and does not account for the change of input current I_{in} as V_{in} crosses the comparator threshold (Figure 8). An increase of the lower threshold $\Delta V_{th(lower)}$ will be observed due to I_{in} which is typically $10 \mu\text{A}$ at 4.3 V . The equations are accurate to $\pm 10\%$ with R_H less than $1.0 \text{ k}\Omega$ and R_L between $4.3 \text{ k}\Omega$ and $43 \text{ k}\Omega$.

Figure 15. Low Voltage Microprocessor Reset With Additional Hysteresis (MC3X164-5 Shown)

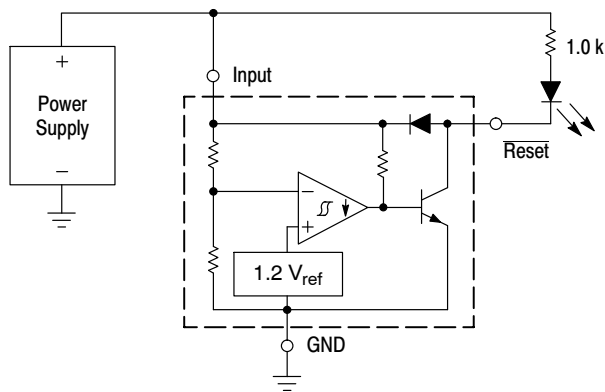

Figure 16. Voltage Monitor

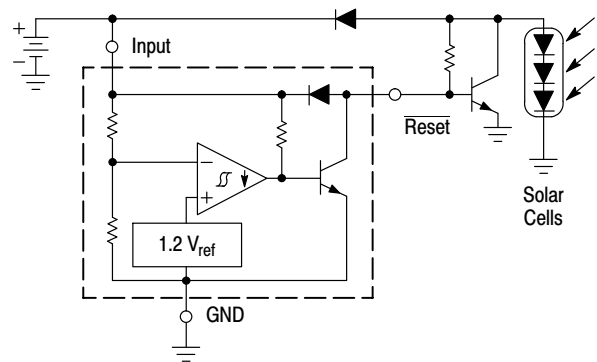
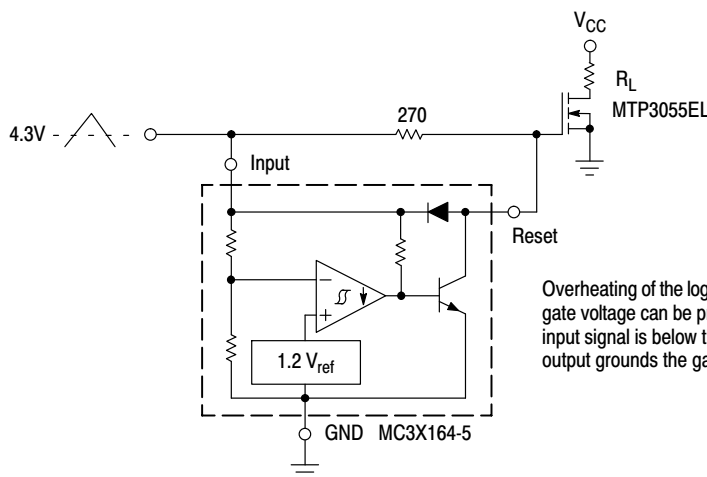

Figure 17. Solar Powered Battery Charger



Overheating of the logic level power MOSFET due to insufficient gate voltage can be prevented with the above circuit. When the input signal is below the 4.3 V threshold of the MC3X164-5, its output grounds the gate of the L^2 MOSFET.

Figure 18. MOSFET Low Voltage Gate Drive Protection Using the MC3X164-5

MC34164, MC33164, NCV33164

ORDERING INFORMATION

| Device | Package | Shipping† |
|-----------------|---------------------|---------------------------|
| MC33164D-3G | SOIC-8 (Pb-Free) | 98 Units / Rail |
| MC33164D-3R2G | SOIC-8 (Pb-Free) | 2,500 Units / Tape & Reel |
| MC33164DM-3R2G | Micro8 (Pb-Free) | 4,000 Units / Tape & Reel |
| MC33164P-3G | TO-92 (Pb-Free) | 2,000 Units / Box |
| MC33164P-3RPG | TO-92 (Pb-Free) | 2,000 Units / Pack |
| MC33164D-5G | SOIC-8 (Pb-Free) | 98 Units / Rail |
| MC33164D-5R2G | SOIC-8 (Pb-Free) | 2,500 Units / Tape & Reel |
| NCV33164D-5R2G* | SOIC-8 (Pb-Free) | |
| MC33164DM-5R2G | Micro8 (Pb-Free) | 4,000 Units / Tape & Reel |
| MC33164P-5G | TO-92 (Pb-Free) | 2,000 Units / Box |
| MC34164D-3R2G | SOIC-8 (Pb-Free) | 2,500 Units / Tape & Reel |
| MC34164D-5R2G | SOIC-8 (Pb-Free) | 2,500 Units / Tape & Reel |
| MC34164P-5G | TO-92 (Pb-Free) | 2,000 Units / Box |

DISCONTINUED (Note 8)

| | | |
|-----------------|---------------------|---------------------------|
| NCV33164D-3R2G* | SOIC-8 (Pb-Free) | 2,500 Units / Tape & Reel |
| MC33164P-3RAG | TO-92 (Pb-Free) | 2,000 Units / Tape & Reel |
| MC33164P-5RAG | TO-92 (Pb-Free) | 2,000 Units / Tape & Reel |
| MC33164P-5RPG | TO-92 (Pb-Free) | 2,000 Units / Pack |
| MC34164D-3G | SOIC-8 (Pb-Free) | 98 Units / Rail |
| MC34164DM-3R2G | Micro8 (Pb-Free) | 4,000 Units / Tape & Reel |
| MC34164P-3G | TO-92 (Pb-Free) | 2,000 Units / Box |
| MC34164P-3RPG | TO-92 (Pb-Free) | 2,000 Units / Pack |
| MC34164D-5G | SOIC-8 (Pb-Free) | 98 Units / Rail |
| MC34164DM-5R2G | Micro8 (Pb-Free) | 4,000 Units / Tape & Reel |
| MC34164SN-5T1G | TSOP-5 (Pb-Free) | 3,000 Units / Tape & Reel |
| MC34164P-5RAG | TO-92 (Pb-Free) | 2,000 Units / Tape & Reel |
| MC34164P-5RPG | TO-92 (Pb-Free) | 2,000 Units / Pack |

† For information on tape and reel specifications, including part orientation and tape sizes, please refer to our Tape and Reel Packaging Specifications Brochure, [BRD8011/D](#).

* NCV33164: $T_{low} = -40\text{ }^{\circ}\text{C}$, $T_{high} = +125\text{ }^{\circ}\text{C}$. Guaranteed by design. NCV prefix is for automotive and other applications requiring site and change control.

8. **DISCONTINUED:** These devices are not available. Please contact your **onsemi** representative for information. The most current information on these devices may be available on www.onsemi.com.

MC34164, MC33164, NCV33164

PIN CONNECTIONS AND MARKING DIAGRAMS

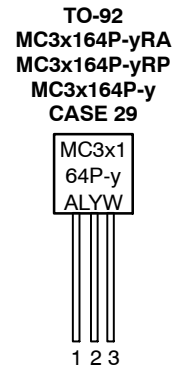
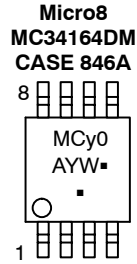
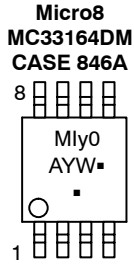
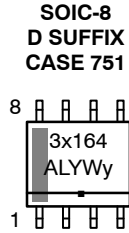
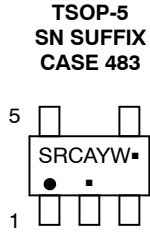

- SRC = Device Code
- x = Device Number 3 or 4
- y = Suffix Number 3 or 5
- A = Assembly Location
- L = Wafer Lot
- Y = Year
- W = Work Week
- = Pb-Free

MC34164, MC33164, NCV33164

REVISION HISTORY

| Revision | Description of Changes | Date |
|----------|--|------------|
| 23 | MC33164P-5RAG and MC33164P-5RPG OPNs marked as discontinued. | 11/13/2025 |

This document has undergone updates prior to the inclusion of this revision history table. The changes tracked here only reflect updates made on the noted approval dates.

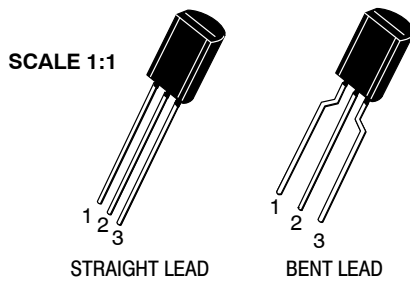

TO-92 (TO-226) 1 WATT
CASE 29-10
ISSUE D

DATE 05 MAR 2021

STRAIGHT LEAD

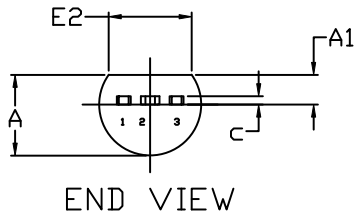

NOTES:

1. DIMENSIONING AND TOLERANCING PER ASME Y14.5M, 2009.
2. CONTROLLING DIMENSION: MILLIMETERS
3. DIMENSIONS D AND E DO NOT INCLUDE MOLD FLASH OR GATE PROTRUSIONS.
4. DIMENSION b AND b2 DOES NOT INCLUDE DAMBAR PROTRUSION. LEAD WIDTH INCLUDING PROTRUSION SHALL NOT EXCEED 0.20. DIMENSION b2 LOCATED ABOVE THE DAMBAR PORTION OF MIDDLE LEAD.

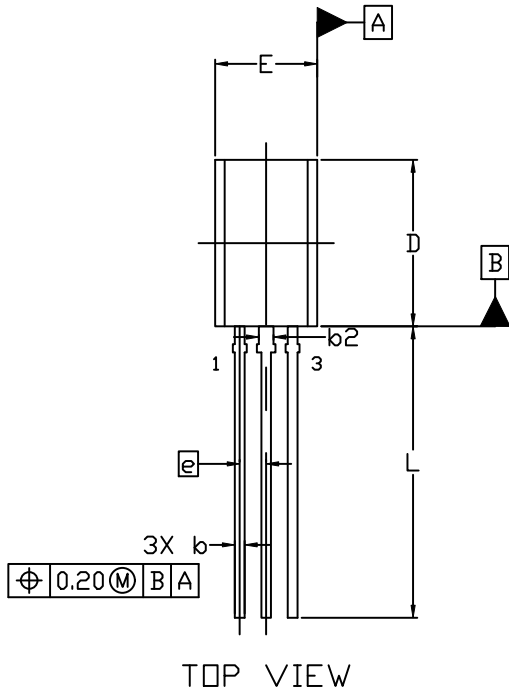

| DIM | MILLIMETERS | | |
|-----|-------------|-------|-------|
| | MIN. | NOM. | MAX. |
| A | 3.75 | 3.90 | 4.05 |
| A1 | 1.28 | 1.43 | 1.58 |
| b | 0.38 | 0.465 | 0.55 |
| b2 | 0.62 | 0.70 | 0.78 |
| c | 0.35 | 0.40 | 0.45 |
| D | 7.85 | 8.00 | 8.15 |
| E | 4.75 | 4.90 | 5.05 |
| E2 | 3.90 | --- | --- |
| e | 1.27 BSC | | |
| L | 13.80 | 14.00 | 14.20 |

STYLES AND MARKING ON PAGE 3

| | | |
|-------------------------|------------------------------|--|
| DOCUMENT NUMBER: | 98AON52857E | Electronic versions are uncontrolled except when accessed directly from the Document Repository. Printed versions are uncontrolled except when stamped "CONTROLLED COPY" in red. |
| DESCRIPTION: | TO-92 (TO-226) 1 WATT | PAGE 1 OF 3 |

onsemi and ONSEMI are trademarks of Semiconductor Components Industries, LLC dba onsemi or its subsidiaries in the United States and/or other countries. onsemi reserves the right to make changes without further notice to any products herein. onsemi makes no warranty, representation or guarantee regarding the suitability of its products for any particular purpose, nor does onsemi assume any liability arising out of the application or use of any product or circuit, and specifically disclaims any and all liability, including without limitation special, consequential or incidental damages. onsemi does not convey any license under its patent rights nor the rights of others.

FORMED LEAD

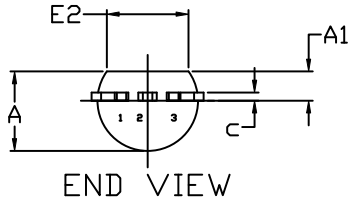

NOTES:

1. DIMENSIONING AND TOLERANCING PER ASME Y14.5M, 2009.
2. CONTROLLING DIMENSION: MILLIMETERS
3. DIMENSIONS D AND E DO NOT INCLUDE MOLD FLASH OR GATE PROTRUSIONS.
4. DIMENSION b AND b2 DOES NOT INCLUDE DAMBAR PROTRUSION. LEAD WIDTH INCLUDING PROTRUSION SHALL NOT EXCEED 0.20. DIMENSION b2 LOCATED ABOVE THE DAMBAR PORTION OF MIDDLE LEAD.

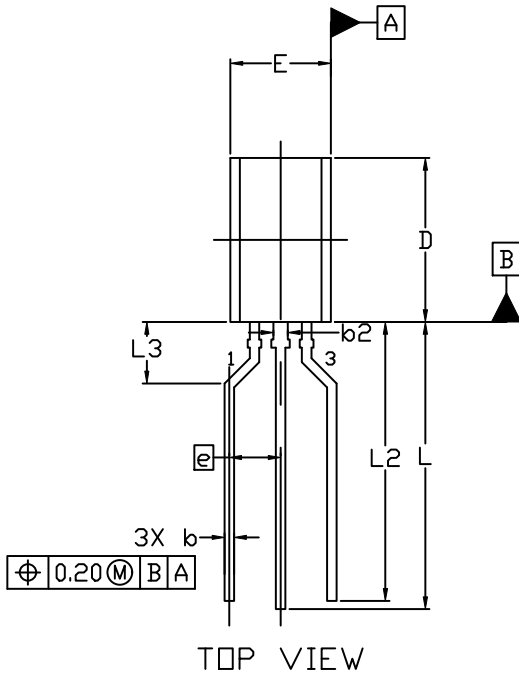

| DIM | MILLIMETERS | | |
|-----|-------------|-------|-------|
| | MIN. | NOM. | MAX. |
| A | 3.75 | 3.90 | 4.05 |
| A1 | 1.28 | 1.43 | 1.58 |
| b | 0.38 | 0.465 | 0.55 |
| b2 | 0.62 | 0.70 | 0.78 |
| c | 0.35 | 0.40 | 0.45 |
| D | 7.85 | 8.00 | 8.15 |
| E | 4.75 | 4.90 | 5.05 |
| E2 | 3.90 | --- | --- |
| e | 2.50 BSC | | |
| L | 13.80 | 14.00 | 14.20 |
| L2 | 13.20 | 13.60 | 14.00 |
| L3 | 3.00 REF | | |

STYLES AND MARKING ON PAGE 3

| | | |
|------------------|-----------------------|--|
| DOCUMENT NUMBER: | 98AON52857E | Electronic versions are uncontrolled except when accessed directly from the Document Repository. Printed versions are uncontrolled except when stamped "CONTROLLED COPY" in red. |
| DESCRIPTION: | TO-92 (TO-226) 1 WATT | PAGE 2 OF 3 |

onsemi and ONSEMI are trademarks of Semiconductor Components Industries, LLC dba onsemi or its subsidiaries in the United States and/or other countries. onsemi reserves the right to make changes without further notice to any products herein. onsemi makes no warranty, representation or guarantee regarding the suitability of its products for any particular purpose, nor does onsemi assume any liability arising out of the application or use of any product or circuit, and specifically disclaims any and all liability, including without limitation special, consequential or incidental damages. onsemi does not convey any license under its patent rights nor the rights of others.

**TO-92 (TO-226) 1 WATT
CASE 29-10
ISSUE D**

DATE 05 MAR 2021

- | | | | | |
|---|--|--|---|---|
| STYLE 1: PIN 1. EMITTER 2. BASE 3. COLLECTOR | STYLE 2: PIN 1. BASE 2. EMITTER 3. COLLECTOR | STYLE 3: PIN 1. ANODE 2. ANODE 3. CATHODE | STYLE 4: PIN 1. CATHODE 2. CATHODE 3. ANODE | STYLE 5: PIN 1. DRAIN 2. SOURCE 3. GATE |
| STYLE 6: PIN 1. GATE 2. SOURCE & SUBSTRATE 3. DRAIN | STYLE 7: PIN 1. SOURCE 2. DRAIN 3. GATE | STYLE 8: PIN 1. DRAIN 2. GATE 3. SOURCE & SUBSTRATE | STYLE 9: PIN 1. BASE 1 2. EMITTER 3. BASE 2 | STYLE 10: PIN 1. CATHODE 2. GATE 3. ANODE |
| STYLE 11: PIN 1. ANODE 2. CATHODE & ANODE 3. CATHODE | STYLE 12: PIN 1. MAIN TERMINAL 1 2. GATE 3. MAIN TERMINAL 2 | STYLE 13: PIN 1. ANODE 1 2. GATE 3. CATHODE 2 | STYLE 14: PIN 1. EMITTER 2. COLLECTOR 3. BASE | STYLE 15: PIN 1. ANODE 1 2. CATHODE 3. ANODE 2 |
| STYLE 16: PIN 1. ANODE 2. GATE 3. CATHODE | STYLE 17: PIN 1. COLLECTOR 2. BASE 3. EMITTER | STYLE 18: PIN 1. ANODE 2. CATHODE 3. NOT CONNECTED | STYLE 19: PIN 1. GATE 2. ANODE 3. CATHODE | STYLE 20: PIN 1. NOT CONNECTED 2. CATHODE 3. ANODE |
| STYLE 21: PIN 1. COLLECTOR 2. EMITTER 3. BASE | STYLE 22: PIN 1. SOURCE 2. GATE 3. DRAIN | STYLE 23: PIN 1. GATE 2. SOURCE 3. DRAIN | STYLE 24: PIN 1. EMITTER 2. COLLECTOR/ANODE 3. CATHODE | STYLE 25: PIN 1. MT 1 2. GATE 3. MT 2 |
| STYLE 26: PIN 1. V _{CC} 2. GROUND 2 3. OUTPUT | STYLE 27: PIN 1. MT 2. SUBSTRATE 3. MT | STYLE 28: PIN 1. CATHODE 2. ANODE 3. GATE | STYLE 29: PIN 1. NOT CONNECTED 2. ANODE 3. CATHODE | STYLE 30: PIN 1. DRAIN 2. GATE 3. SOURCE |
| STYLE 31: PIN 1. GATE 2. DRAIN 3. SOURCE | STYLE 32: PIN 1. BASE 2. COLLECTOR 3. EMITTER | STYLE 33: PIN 1. RETURN 2. INPUT 3. OUTPUT | STYLE 34: PIN 1. INPUT 2. GROUND 3. LOGIC | STYLE 35: PIN 1. GATE 2. COLLECTOR 3. EMITTER |

**GENERIC
MARKING DIAGRAM***

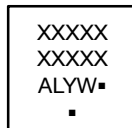

- XXXX = Specific Device Code
A = Assembly Location
L = Wafer Lot
Y = Year
W = Work Week
▪ = Pb-Free Package

(Note: Microdot may be in either location)

*This information is generic. Please refer to device data sheet for actual part marking. Pb-Free indicator, "G" or microdot "▪", may or may not be present. Some products may not follow the Generic Marking.

| | | |
|-------------------------|------------------------------|---|
| DOCUMENT NUMBER: | 98AON52857E | Electronic versions are uncontrolled except when accessed directly from the Document Repository. Printed versions are uncontrolled except when stamped "CONTROLLED COPY" in red. |
| DESCRIPTION: | TO-92 (TO-226) 1 WATT | PAGE 3 OF 3 |

onsemi and **ONSEMI** are trademarks of Semiconductor Components Industries, LLC dba **onsemi** or its subsidiaries in the United States and/or other countries. **onsemi** reserves the right to make changes without further notice to any products herein. **onsemi** makes no warranty, representation or guarantee regarding the suitability of its products for any particular purpose, nor does **onsemi** assume any liability arising out of the application or use of any product or circuit, and specifically disclaims any and all liability, including without limitation special, consequential or incidental damages. **onsemi** does not convey any license under its patent rights nor the rights of others.



SCALE 1:1

SOIC-8 NB
CASE 751-07
ISSUE AK

DATE 16 FEB 2011

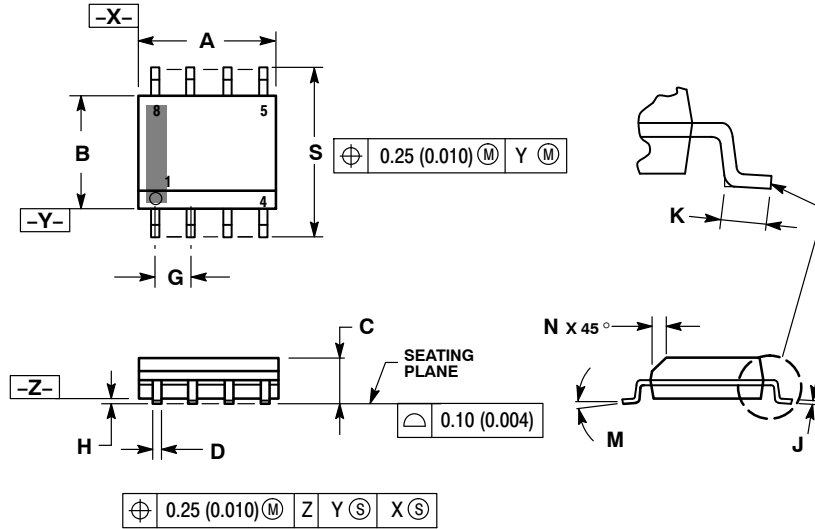

- NOTES:
1. DIMENSIONING AND TOLERANCING PER ANSI Y14.5M, 1982.
 2. CONTROLLING DIMENSION: MILLIMETER.
 3. DIMENSION A AND B DO NOT INCLUDE MOLD PROTRUSION.
 4. MAXIMUM MOLD PROTRUSION 0.15 (0.006) PER SIDE.
 5. DIMENSION D DOES NOT INCLUDE DAMBAR PROTRUSION. ALLOWABLE DAMBAR PROTRUSION SHALL BE 0.127 (0.005) TOTAL IN EXCESS OF THE D DIMENSION AT MAXIMUM MATERIAL CONDITION.
 6. 751-01 THRU 751-06 ARE OBSOLETE. NEW STANDARD IS 751-07.

| DIM | MILLIMETERS | | INCHES | |
|-----|-------------|------|-----------|-------|
| | MIN | MAX | MIN | MAX |
| A | 4.80 | 5.00 | 0.189 | 0.197 |
| B | 3.80 | 4.00 | 0.150 | 0.157 |
| C | 1.35 | 1.75 | 0.053 | 0.069 |
| D | 0.33 | 0.51 | 0.013 | 0.020 |
| G | 1.27 BSC | | 0.050 BSC | |
| H | 0.10 | 0.25 | 0.004 | 0.010 |
| J | 0.19 | 0.25 | 0.007 | 0.010 |
| K | 0.40 | 1.27 | 0.016 | 0.050 |
| M | 0° | 8° | 0° | 8° |
| N | 0.25 | 0.50 | 0.010 | 0.020 |
| S | 5.80 | 6.20 | 0.228 | 0.244 |

SOLDERING FOOTPRINT*

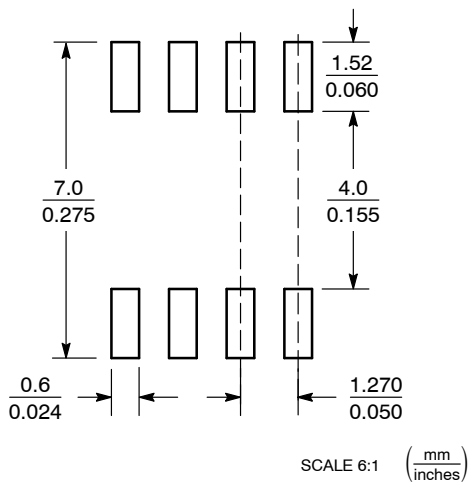

*For additional information on our Pb-Free strategy and soldering details, please download the onsemi Soldering and Mounting Techniques Reference Manual, SOLDERRM/D.

GENERIC MARKING DIAGRAM*

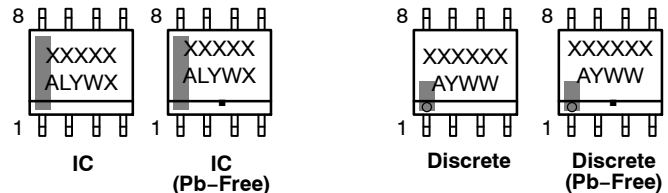

XXXXXX = Specific Device Code
A = Assembly Location
L = Wafer Lot
Y = Year
W = Work Week
▪ = Pb-Free Package

XXXXXX = Specific Device Code
A = Assembly Location
Y = Year
WW = Work Week
▪ = Pb-Free Package

*This information is generic. Please refer to device data sheet for actual part marking. Pb-Free indicator, "G" or microdot "▪", may or may not be present. Some products may not follow the Generic Marking.

STYLES ON PAGE 2

| | | |
|------------------|-------------|--|
| DOCUMENT NUMBER: | 98ASB42564B | Electronic versions are uncontrolled except when accessed directly from the Document Repository. Printed versions are uncontrolled except when stamped "CONTROLLED COPY" in red. |
| DESCRIPTION: | SOIC-8 NB | PAGE 1 OF 2 |

onsemi and onsemi are trademarks of Semiconductor Components Industries, LLC dba onsemi or its subsidiaries in the United States and/or other countries. onsemi reserves the right to make changes without further notice to any products herein. onsemi makes no warranty, representation or guarantee regarding the suitability of its products for any particular purpose, nor does onsemi assume any liability arising out of the application or use of any product or circuit, and specifically disclaims any and all liability, including without limitation special, consequential or incidental damages. onsemi does not convey any license under its patent rights nor the rights of others.

SOIC-8 NB
CASE 751-07
ISSUE AK

DATE 16 FEB 2011

- | | | | |
|--|---|---|---|
| <p>STYLE 1: PIN 1. EMITTER 2. COLLECTOR 3. COLLECTOR 4. EMITTER 5. EMITTER 6. BASE 7. BASE 8. EMITTER</p> | <p>STYLE 2: PIN 1. COLLECTOR, DIE, #1 2. COLLECTOR, #1 3. COLLECTOR, #2 4. COLLECTOR, #2 5. BASE, #2 6. EMITTER, #2 7. BASE, #1 8. EMITTER, #1</p> | <p>STYLE 3: PIN 1. DRAIN, DIE #1 2. DRAIN, #1 3. DRAIN, #2 4. DRAIN, #2 5. GATE, #2 6. SOURCE, #2 7. GATE, #1 8. SOURCE, #1</p> | <p>STYLE 4: PIN 1. ANODE 2. ANODE 3. ANODE 4. ANODE 5. ANODE 6. ANODE 7. ANODE 8. COMMON CATHODE</p> |
| <p>STYLE 5: PIN 1. DRAIN 2. DRAIN 3. DRAIN 4. DRAIN 5. GATE 6. GATE 7. SOURCE 8. SOURCE</p> | <p>STYLE 6: PIN 1. SOURCE 2. DRAIN 3. DRAIN 4. SOURCE 5. SOURCE 6. GATE 7. GATE 8. SOURCE</p> | <p>STYLE 7: PIN 1. INPUT 2. EXTERNAL BYPASS 3. THIRD STAGE SOURCE 4. GROUND 5. DRAIN 6. GATE 3 7. SECOND STAGE Vd 8. FIRST STAGE Vd</p> | <p>STYLE 8: PIN 1. COLLECTOR, DIE #1 2. BASE, #1 3. BASE, #2 4. COLLECTOR, #2 5. COLLECTOR, #2 6. EMITTER, #2 7. EMITTER, #1 8. COLLECTOR, #1</p> |
| <p>STYLE 9: PIN 1. EMITTER, COMMON 2. COLLECTOR, DIE #1 3. COLLECTOR, DIE #2 4. EMITTER, COMMON 5. EMITTER, COMMON 6. BASE, DIE #2 7. BASE, DIE #1 8. EMITTER, COMMON</p> | <p>STYLE 10: PIN 1. GROUND 2. BIAS 1 3. OUTPUT 4. GROUND 5. GROUND 6. BIAS 2 7. INPUT 8. GROUND</p> | <p>STYLE 11: PIN 1. SOURCE 1 2. GATE 1 3. SOURCE 2 4. GATE 2 5. DRAIN 2 6. DRAIN 2 7. DRAIN 1 8. DRAIN 1</p> | <p>STYLE 12: PIN 1. SOURCE 2. SOURCE 3. SOURCE 4. GATE 5. DRAIN 6. DRAIN 7. DRAIN 8. DRAIN</p> |
| <p>STYLE 13: PIN 1. N.C. 2. SOURCE 3. SOURCE 4. GATE 5. DRAIN 6. DRAIN 7. DRAIN 8. DRAIN</p> | <p>STYLE 14: PIN 1. N-SOURCE 2. N-GATE 3. P-SOURCE 4. P-GATE 5. P-DRAIN 6. P-DRAIN 7. N-DRAIN 8. N-DRAIN</p> | <p>STYLE 15: PIN 1. ANODE 1 2. ANODE 1 3. ANODE 1 4. ANODE 1 5. CATHODE, COMMON 6. CATHODE, COMMON 7. CATHODE, COMMON 8. CATHODE, COMMON</p> | <p>STYLE 16: PIN 1. EMITTER, DIE #1 2. BASE, DIE #1 3. EMITTER, DIE #2 4. BASE, DIE #2 5. COLLECTOR, DIE #2 6. COLLECTOR, DIE #2 7. COLLECTOR, DIE #1 8. COLLECTOR, DIE #1</p> |
| <p>STYLE 17: PIN 1. VCC 2. V2OUT 3. V1OUT 4. TXE 5. RXE 6. VEE 7. GND 8. ACC</p> | <p>STYLE 18: PIN 1. ANODE 2. ANODE 3. SOURCE 4. GATE 5. DRAIN 6. DRAIN 7. CATHODE 8. CATHODE</p> | <p>STYLE 19: PIN 1. SOURCE 1 2. GATE 1 3. SOURCE 2 4. GATE 2 5. DRAIN 2 6. MIRROR 2 7. DRAIN 1 8. MIRROR 1</p> | <p>STYLE 20: PIN 1. SOURCE (N) 2. GATE (N) 3. SOURCE (P) 4. GATE (P) 5. DRAIN 6. DRAIN 7. DRAIN 8. DRAIN</p> |
| <p>STYLE 21: PIN 1. CATHODE 1 2. CATHODE 2 3. CATHODE 3 4. CATHODE 4 5. CATHODE 5 6. COMMON ANODE 7. COMMON ANODE 8. CATHODE 6</p> | <p>STYLE 22: PIN 1. I/O LINE 1 2. COMMON CATHODE/VCC 3. COMMON CATHODE/VCC 4. I/O LINE 3 5. COMMON ANODE/GND 6. I/O LINE 4 7. I/O LINE 5 8. COMMON ANODE/GND</p> | <p>STYLE 23: PIN 1. LINE 1 IN 2. COMMON ANODE/GND 3. COMMON ANODE/GND 4. LINE 2 IN 5. LINE 2 OUT 6. COMMON ANODE/GND 7. COMMON ANODE/GND 8. LINE 1 OUT</p> | <p>STYLE 24: PIN 1. BASE 2. EMITTER 3. COLLECTOR/ANODE 4. COLLECTOR/ANODE 5. CATHODE 6. CATHODE 7. COLLECTOR/ANODE 8. COLLECTOR/ANODE</p> |
| <p>STYLE 25: PIN 1. VIN 2. N/C 3. REXT 4. GND 5. IOUT 6. IOUT 7. IOUT 8. IOUT</p> | <p>STYLE 26: PIN 1. GND 2. dv/dt 3. ENABLE 4. ILIMIT 5. SOURCE 6. SOURCE 7. SOURCE 8. VCC</p> | <p>STYLE 27: PIN 1. ILIMIT 2. OVLO 3. UVLO 4. INPUT+ 5. SOURCE 6. SOURCE 7. SOURCE 8. DRAIN</p> | <p>STYLE 28: PIN 1. SW_TO_GND 2. DASIC OFF 3. DASIC_SW_DET 4. GND 5. V_MON 6. VBULK 7. VBULK 8. VIN</p> |
| <p>STYLE 29: PIN 1. BASE, DIE #1 2. EMITTER, #1 3. BASE, #2 4. EMITTER, #2 5. COLLECTOR, #2 6. COLLECTOR, #2 7. COLLECTOR, #1 8. COLLECTOR, #1</p> | <p>STYLE 30: PIN 1. DRAIN 1 2. DRAIN 1 3. GATE 2 4. SOURCE 2 5. SOURCE 1/DRAIN 2 6. SOURCE 1/DRAIN 2 7. SOURCE 1/DRAIN 2 8. GATE 1</p> | | |

| | | |
|-------------------------|--------------------|---|
| DOCUMENT NUMBER: | 98ASB42564B | Electronic versions are uncontrolled except when accessed directly from the Document Repository. Printed versions are uncontrolled except when stamped "CONTROLLED COPY" in red. |
| DESCRIPTION: | SOIC-8 NB | PAGE 2 OF 2 |

onsemi and **ONSEMI** are trademarks of Semiconductor Components Industries, LLC dba **onsemi** or its subsidiaries in the United States and/or other countries. **onsemi** reserves the right to make changes without further notice to any products herein. **onsemi** makes no warranty, representation or guarantee regarding the suitability of its products for any particular purpose, nor does **onsemi** assume any liability arising out of the application or use of any product or circuit, and specifically disclaims any and all liability, including without limitation special, consequential or incidental damages. **onsemi** does not convey any license under its patent rights nor the rights of others.



SCALE 2:1

Micro8
CASE 846A-02
ISSUE K

DATE 16 JUL 2020

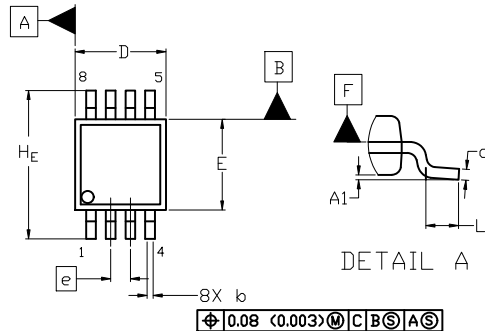

TOP VIEW

NOTE 3

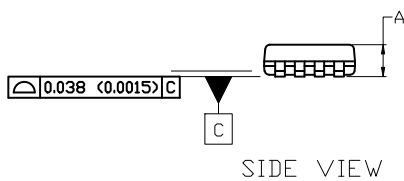

SIDE VIEW

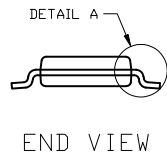

END VIEW

NOTES:

1. DIMENSIONING AND TOLERANCING PER ASME Y14.5M, 2009.
2. CONTROLLING DIMENSION: MILLIMETERS
3. DIMENSION *b* DOES NOT INCLUDE DAMBAR PROTRUSION. ALLOWABLE PROTRUSION SHALL BE 0.10 mm IN EXCESS OF MAXIMUM MATERIAL CONDITION.
4. DIMENSIONS *D* AND *E* DO NOT INCLUDE MOLD FLASH, PROTRUSION OR GATE BURRS. MOLD FLASH, PROTRUSIONS, OR GATE BURRS SHALL NOT EXCEED 0.15 mm PER SIDE. DIMENSION *E* DOES NOT INCLUDE INTERLEAD FLASH OR PROTRUSION. INTERLEAD FLASH OR PROTRUSION SHALL NOT EXCEED 0.25 mm PER SIDE. DIMENSIONS *D* AND *E* ARE DETERMINED AT DATUM *F*.
5. DATUMS *A* AND *B* ARE TO BE DETERMINED AT DATUM *F*.
6. *A1* IS DEFINED AS THE VERTICAL DISTANCE FROM THE SEATING PLANE TO THE LOWEST POINT ON THE PACKAGE BODY.

⌀ 0.08 (0.003) M C B S A S

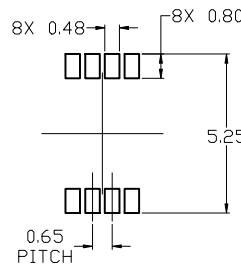

RECOMMENDED MOUNTING FOOTPRINT

| DIM | MILLIMETERS | | |
|----------------------|-------------|------|------|
| | MIN. | NOM. | MAX. |
| A | --- | --- | 1.10 |
| A1 | 0.05 | 0.08 | 0.15 |
| <i>b</i> | 0.25 | 0.33 | 0.40 |
| <i>c</i> | 0.13 | 0.18 | 0.23 |
| <i>D</i> | 2.90 | 3.00 | 3.10 |
| <i>E</i> | 2.90 | 3.00 | 3.10 |
| <i>e</i> | 0.65 BSC | | |
| <i>H_E</i> | 4.75 | 4.90 | 5.05 |
| <i>L</i> | 0.40 | 0.55 | 0.70 |

For additional information on our Pb-Free strategy and soldering details, please download the [DN Semiconductor Soldering and Mounting Techniques Reference Manual, SOLDERM/D](#).

GENERIC MARKING DIAGRAM*

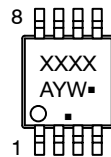

- XXXX = Specific Device Code
- A = Assembly Location
- Y = Year
- W = Work Week
- = Pb-Free Package

(Note: Microdot may be in either location)

*This information is generic. Please refer to device data sheet for actual part marking. Pb-Free indicator, "G" or microdot "▪", may or may not be present. Some products may not follow the Generic Marking.

STYLE 1:

1. SOURCE
2. SOURCE
3. SOURCE
4. GATE
5. DRAIN
6. DRAIN
7. DRAIN
8. DRAIN

STYLE 2:

1. SOURCE 1
2. GATE 1
3. SOURCE 2
4. GATE 2
5. DRAIN 2
6. DRAIN 2
7. DRAIN 1
8. DRAIN 1

STYLE 3:

1. N-SOURCE
2. N-GATE
3. P-SOURCE
4. P-GATE
5. P-DRAIN
6. P-DRAIN
7. N-DRAIN
8. N-DRAIN

| | | |
|------------------|-------------|--|
| DOCUMENT NUMBER: | 98ASB14087C | Electronic versions are uncontrolled except when accessed directly from the Document Repository. Printed versions are uncontrolled except when stamped "CONTROLLED COPY" in red. |
| DESCRIPTION: | MICRO8 | PAGE 1 OF 1 |

onsemi and ONSEMI are trademarks of Semiconductor Components Industries, LLC dba onsemi or its subsidiaries in the United States and/or other countries. onsemi reserves the right to make changes without further notice to any products herein. onsemi makes no warranty, representation or guarantee regarding the suitability of its products for any particular purpose, nor does onsemi assume any liability arising out of the application or use of any product or circuit, and specifically disclaims any and all liability, including without limitation special, consequential or incidental damages. onsemi does not convey any license under its patent rights nor the rights of others.

onsemi, **Onsemi**, and other names, marks, and brands are registered and/or common law trademarks of Semiconductor Components Industries, LLC dba "**onsemi**" or its affiliates and/or subsidiaries in the United States and/or other countries. **onsemi** owns the rights to a number of patents, trademarks, copyrights, trade secrets, and other intellectual property. A listing of **onsemi**'s product/patent coverage may be accessed at www.onsemi.com/site/pdf/Patent-Marking.pdf. **onsemi** reserves the right to make changes at any time to any products or information herein, without notice. The information herein is provided "as-is" and **onsemi** makes no warranty, representation or guarantee regarding the accuracy of the information, product features, availability, functionality, or suitability of its products for any particular purpose, nor does **onsemi** assume any liability arising out of the application or use of any product or circuit, and specifically disclaims any and all liability, including without limitation special, consequential or incidental damages. Buyer is responsible for its products and applications using **onsemi** products, including compliance with all laws, regulations and safety requirements or standards, regardless of any support or applications information provided by **onsemi**. "Typical" parameters which may be provided in **onsemi** data sheets and/or specifications can and do vary in different applications and actual performance may vary over time. All operating parameters, including "Typicals" must be validated for each customer application by customer's technical experts. **onsemi** does not convey any license under any of its intellectual property rights nor the rights of others. **onsemi** products are not designed, intended, or authorized for use as a critical component in life support systems or any FDA Class 3 medical devices or medical devices with a same or similar classification in a foreign jurisdiction or any devices intended for implantation in the human body. Should Buyer purchase or use **onsemi** products for any such unintended or unauthorized application, Buyer shall indemnify and hold **onsemi** and its officers, employees, subsidiaries, affiliates, and distributors harmless against all claims, costs, damages, and expenses, and reasonable attorney fees arising out of, directly or indirectly, any claim of personal injury or death associated with such unintended or unauthorized use, even if such claim alleges that **onsemi** was negligent regarding the design or manufacture of the part. **onsemi** is an Equal Opportunity/Affirmative Action Employer. This literature is subject to all applicable copyright laws and is not for resale in any manner.

ADDITIONAL INFORMATION

TECHNICAL PUBLICATIONS:

Technical Library: www.onsemi.com/design/resources/technical-documentation
onsemi Website: www.onsemi.com

ONLINE SUPPORT: www.onsemi.com/support

For additional information, please contact your local Sales Representative at www.onsemi.com/support/sales

