

2.5 V/3.3 V ECL Differential Receiver/Driver

MC10LVEP16, MC100LVEP16

Description

The MC10/100LVEP16 is a world class differential receiver/driver. The device is functionally equivalent to the EL16, EP16 and LVEL16 devices. With output transition times significantly faster than the EL16 and LVEL16, the LVEP16 is ideally suited for interfacing with high frequency and low voltage (2.5 V) sources. Single-Ended CLK input operation is limited to a $V_{CC} \geq 3.0$ V in PECL mode, or $V_{EE} \leq -3.0$ V in NECL mode.

The V_{BB} pin, an internally generated Voltage supply, is available to this device only. For Single-Ended input conditions, the unused differential input is connected to V_{BB} as a switching reference voltage. V_{BB} may also rebias AC coupled inputs. When used, decouple V_{BB} and V_{CC} via a 0.01 μ F capacitor and limit current sourcing or sinking to 0.5 mA. When not used, V_{BB} should be left open.

The 100 Series contains temperature compensation.

Features

- 240 ps Propagation Delay
- Maximum Frequency = > 4 GHz Typical
- PECL Mode Operating Range:
 $V_{CC} = 2.375$ V to 3.8 V with $V_{EE} = 0$ V
- NECL Mode Operating Range:
 $V_{CC} = 0$ V with $V_{EE} = -2.375$ V to -3.8 V
- V_{BB} Output
- Open Input Default State
- LVDS Input Compatible
- These Devices are Pb-Free, Halogen Free and are RoHS Compliant

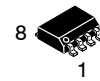

SOIC-8 NB
D SUFFIX
CASE 751-07



TSSOP-8
DT SUFFIX
CASE 948R-02

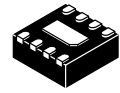

DFN8
MN SUFFIX
CASE 506AA

MARKING DIAGRAMS*

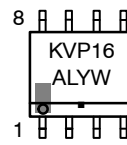

SOIC-8 NB

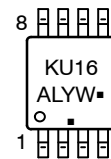

TSSOP-8

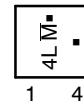

DFN8

H = MC10 L = Wafer Lot
K = MC100 Y = Year
4L = MC100 W = Work Week
M = Date Code ■ = Pb-Free Package
A = Assembly Location
(Note: Microdot may be in either location)

*For additional marking information, refer to Application Note [AND8002/D](#).

ORDERING INFORMATION

See detailed ordering and shipping information in the package dimensions section on page 7 of this data sheet.

NOTE: Some of the devices on this data sheet have been **DISCONTINUED**. Please refer to the table on page 7.

MC10LVEP16, MC100LVEP16

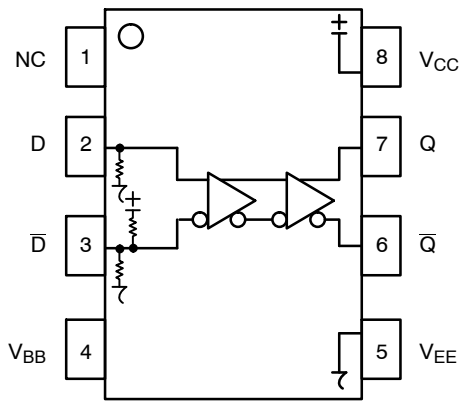

Figure 1. 8-Lead Pinout (Top View) and Logic Diagram

Table 1. PIN DESCRIPTION

| Pin | Function |
|--------------------|--|
| D*, \bar{D}^{**} | ECL Data Inputs |
| Q, \bar{Q} | ECL Data Outputs |
| V _{BB} | Ref. Voltage Output |
| V _{CC} | Positive Supply |
| V _{EE} | Negative Supply |
| NC | No Connect |
| EP | (DFN8 only) Thermal exposed pad must be connected to a sufficient thermal conduit. Electrically connect to the most negative supply (GND) or leave unconnected, floating open. |

* Pins will default LOW when left open.

**Pins will default to $V_{CC}/2$ when left open.

Table 2. ATTRIBUTES

| Characteristics | Value |
|---|-------------------------------|
| Internal Input Pulldown Resistor | 75 k Ω |
| Internal Input Pullup Resistor | 37.5 k Ω |
| ESD Protection Human Body Model Machine Model Charged Device Model | > 4 kV > 200 V > 2 kV |
| Moisture Sensitivity, Indefinite Time Out of Drypack (Note 1) | Pb-Free Pkg |
| SOIC-8 NB TSSOP-8 DFN8 | Level 1 Level 3 Level 1 |
| Flammability Rating Oxygen Index: 28 to 34 | UL 94 V-0 @ 0.125 in |
| Transistor Count | 167 Devices |
| Meets or exceeds JEDEC Spec EIA/JESD78 IC Latchup Test | |

1. For additional information, see Application Note [AND8003/D](#).

MC10LVEP16, MC100LVEP16

Table 3. MAXIMUM RATINGS

| Symbol | Parameter | Condition 1 | Condition 2 | Rating | Unit |
|------------------|--|--|--|-------------|------|
| V _{CC} | PECL Mode Power Supply | V _{EE} = 0 V | | 6 | V |
| V _{EE} | NECL Mode Power Supply | V _{CC} = 0 V | | -6 | V |
| V _I | PECL Mode Input Voltage NECL Mode Input Voltage | V _{EE} = 0 V V _{CC} = 0 V | V _I ≤ V _{CC} V _I ≥ V _{EE} | 6 -6 | V |
| I _{out} | Output Current | Continuous Surge | | 50 100 | mA |
| I _{BB} | V _{BB} Sink/Source | | | ±0.5 | mA |
| T _A | Operating Temperature Range | | | -40 to +85 | °C |
| T _{stg} | Storage Temperature Range | | | -65 to +150 | °C |
| θ _{JA} | Thermal Resistance (Junction-to-Ambient) | 0 lfpm 500 lfpm | SOIC-8 NB SOIC-8 NB | 190 130 | °C/W |
| θ _{JC} | Thermal Resistance (Junction-to-Case) | Standard Board | SOIC-8 NB | 41 to 44 | °C/W |
| θ _{JA} | Thermal Resistance (Junction-to-Ambient) | 0 lfpm 500 lfpm | TSSOP-8 TSSOP-8 | 185 140 | °C/W |
| θ _{JC} | Thermal Resistance (Junction-to-Case) | Standard Board | TSSOP-8 | 41 to 44 | °C/W |
| θ _{JA} | Thermal Resistance (Junction-to-Ambient) | 0 lfpm 500 lfpm | DFN8 DFN8 | 129 84 | °C/W |
| θ _{JC} | Thermal Resistance (Junction-to-Case) | (Note 1) | DFN8 | 35 to 40 | °C/W |
| T _{sol} | Wave Solder (Pb-Free) | < 2 to 3 sec @ 260°C | | 265 | °C |

Stresses exceeding those listed in the Maximum Ratings table may damage the device. If any of these limits are exceeded, device functionality should not be assumed, damage may occur and reliability may be affected.

1. JEDEC standard multilayer board – 2S2P (2 signal, 2 power).

Table 4. 10EP DC CHARACTERISTICS, PECL (V_{CC} = 2.5 V, V_{EE} = 0 V (Note 1))

| Symbol | Characteristic | -40°C | | | 25°C | | | 85°C | | | Unit |
|--------------------|--|-------|------|------|------|------|------|------|------|------|------|
| | | Min | Typ | Max | Min | Typ | Max | Min | Typ | Max | |
| I _{EE} | Power Supply Current | 17 | 22 | 27 | 17 | 22 | 27 | 17 | 22 | 28 | mA |
| V _{OH} | Output HIGH Voltage (Note 2) | 1365 | 1490 | 1615 | 1430 | 1555 | 1680 | 1490 | 1615 | 1740 | mV |
| V _{OL} | Output LOW Voltage (Note 2) | 565 | 740 | 865 | 630 | 805 | 930 | 690 | 865 | 990 | mV |
| V _{IHCMR} | Input HIGH Voltage Common Mode Range (Differential Configuration) (Notes 3, 4) | 1.2 | | 2.5 | 1.2 | | 2.5 | 1.2 | | 2.5 | V |
| I _{IH} | Input HIGH Current | | | 150 | | | 150 | | | 150 | μA |
| I _{IL} | Input LOW Current | | | | | | | | | | μA |
| | D | 0.5 | | | 0.5 | | | 0.5 | | | |
| | D̄ | -150 | | | -150 | | | -150 | | | |

NOTE: Device will meet the specifications after thermal equilibrium has been established when mounted in a test socket or printed circuit board with maintained transverse airflow greater than 500 lfpm.

1. Input and output parameters vary 1:1 with V_{CC}. V_{EE} can vary +0.125 V to -1.3 V.
2. All loading with 50 Ω to V_{CC} - 2.0 V.
3. Do not use V_{BB} at V_{CC} < 3.0 V. Single ended input CLK pin operation is limited to V_{CC} ≥ 3.0 V in PECL mode.
4. V_{IHCMR} min varies 1:1 with V_{EE}. V_{IHCMR} max varies 1:1 with V_{CC}. The V_{IHCMR} range is referenced to the most positive side of the differential input signal.

MC10LVEP16, MC100LVEP16

Table 5. 10EP DC CHARACTERISTICS, PECL ($V_{CC} = 3.3\text{ V}$, $V_{EE} = 0\text{ V}$ (Note 1))

| Symbol | Characteristic | -40°C | | | 25°C | | | 85°C | | | Unit |
|-------------|--|-------------|------|------|-------------|------|------|-------------|------|------|---------------|
| | | Min | Typ | Max | Min | Typ | Max | Min | Typ | Max | |
| I_{EE} | Power Supply Current | 17 | 22 | 27 | 17 | 22 | 27 | 17 | 22 | 28 | mA |
| V_{OH} | Output HIGH Voltage (Note 2) | 2165 | 2290 | 2415 | 2230 | 2355 | 2480 | 2290 | 2415 | 2540 | mV |
| V_{OL} | Output LOW Voltage (Note 2) | 1365 | 1540 | 1665 | 1430 | 1605 | 1730 | 1490 | 1665 | 1790 | mV |
| V_{IH} | Input HIGH Voltage (Single Ended) | 2090 | | 2415 | 2155 | | 2480 | 2215 | | 2540 | mV |
| V_{IL} | Input LOW Voltage (Single Ended) | 1365 | | 1690 | 1430 | | 1755 | 1490 | | 1815 | mV |
| V_{BB} | Output Voltage Reference (Note 3) | 1790 | 1890 | 1990 | 1855 | 1955 | 2055 | 1915 | 2015 | 2115 | mV |
| V_{IHCMR} | Input HIGH Voltage Common Mode Range (Differential Configuration) (Note 4) | 1.2 | | 3.3 | 1.2 | | 3.3 | 1.2 | | 3.3 | V |
| I_{IH} | Input HIGH Current | | | 150 | | | 150 | | | 150 | μA |
| I_{IL} | Input LOW Current D \bar{D} | 0.5 -150 | | | 0.5 -150 | | | 0.5 -150 | | | μA |

NOTE: Device will meet the specifications after thermal equilibrium has been established when mounted in a test socket or printed circuit board with maintained transverse airflow greater than 500 lpm.

1. Input and output parameters vary 1:1 with V_{CC} . V_{EE} can vary +0.925 V to -0.5 V.
2. All loading with 50 Ω to $V_{CC} - 2.0\text{ V}$.
3. Single ended input CLK pin operation is limited to $V_{CC} \geq 3.0\text{ V}$ in PECL mode.
4. V_{IHCMR} min varies 1:1 with V_{EE} , V_{IHCMR} max varies 1:1 with V_{CC} . The V_{IHCMR} range is referenced to the most positive side of the differential input signal.

Table 6. 10EP DC CHARACTERISTICS, NECL ($V_{CC} = 0\text{ V}$, $V_{EE} = -3.8\text{ V}$ to -2.375 V (Note 1))

| Symbol | Characteristic | -40°C | | | 25°C | | | 85°C | | | Unit |
|-------------|--|--------------|-------|-------|--------------|-------|-------|--------------|-------|-------|---------------|
| | | Min | Typ | Max | Min | Typ | Max | Min | Typ | Max | |
| I_{EE} | Power Supply Current | 17 | 22 | 27 | 17 | 22 | 27 | 17 | 22 | 28 | mA |
| V_{OH} | Output HIGH Voltage (Note 2) | -1135 | -1010 | -885 | -1070 | -945 | -820 | -1010 | -885 | -760 | mV |
| V_{OL} | Output LOW Voltage (Note 2) | -1935 | -1760 | -1635 | -1870 | -1695 | -1570 | -1810 | -1635 | -1510 | mV |
| V_{IH} | Input HIGH Voltage (Single Ended) | -1210 | | -885 | -1145 | | -820 | -1085 | | -760 | mV |
| V_{IL} | Input LOW Voltage (Single Ended) | -1935 | | -1610 | -1870 | | -1545 | -1810 | | -1485 | mV |
| V_{BB} | Output Voltage Reference (Note 3) | -1510 | -1410 | -1310 | -1445 | -1345 | -1245 | -1385 | -1285 | -1185 | mV |
| V_{IHCMR} | Input HIGH Voltage Common Mode Range (Differential Configuration) (Note 4) | $V_{EE}+1.2$ | | 0.0 | $V_{EE}+1.2$ | | 0.0 | $V_{EE}+1.2$ | | 0.0 | V |
| I_{IH} | Input HIGH Current | | | 150 | | | 150 | | | 150 | μA |
| I_{IL} | Input LOW Current D \bar{D} | 0.5 -150 | | | 0.5 -150 | | | 0.5 -150 | | | μA |

NOTE: Device will meet the specifications after thermal equilibrium has been established when mounted in a test socket or printed circuit board with maintained transverse airflow greater than 500 lpm.

1. Input and output parameters vary 1:1 with V_{CC} .
2. All loading with 50 Ω to $V_{CC} - 2.0\text{ V}$.
3. Single ended input CLK pin operation is limited to $V_{EE} \leq -3.0\text{ V}$ in NECL mode.
4. V_{IHCMR} min varies 1:1 with V_{EE} , V_{IHCMR} max varies 1:1 with V_{CC} . The V_{IHCMR} range is referenced to the most positive side of the differential input signal.

MC10LVEP16, MC100LVEP16

Table 7. 100EP DC CHARACTERISTICS, PECL ($V_{CC} = 2.5\text{ V}$, $V_{EE} = 0\text{ V}$ (Note 1))

| Symbol | Characteristic | -40°C | | | 25°C | | | 85°C | | | Unit |
|-------------|--|-------------|------|------|-------------|------|------|-------------|------|------|---------------|
| | | Min | Typ | Max | Min | Typ | Max | Min | Typ | Max | |
| I_{EE} | Power Supply Current | 19 | 24 | 29 | 22 | 28 | 34 | 24 | 30 | 36 | mA |
| V_{OH} | Output HIGH Voltage (Note 2) | 1355 | 1480 | 1605 | 1355 | 1480 | 1605 | 1355 | 1480 | 1605 | mV |
| V_{OL} | Output LOW Voltage (Note 2) | 555 | 730 | 900 | 555 | 730 | 900 | 555 | 730 | 900 | mV |
| V_{IHCMR} | Input HIGH Voltage Common Mode Range (Differential Configuration) (Notes 3, 4) | 1.2 | | 3.3 | 1.2 | | 3.3 | 1.2 | | 3.3 | V |
| I_{IH} | Input HIGH Current | | | 150 | | | 150 | | | 150 | μA |
| I_{IL} | Input LOW Current D \bar{D} | 0.5 -150 | | | 0.5 -150 | | | 0.5 -150 | | | μA |

NOTE: Device will meet the specifications after thermal equilibrium has been established when mounted in a test socket or printed circuit board with maintained transverse airflow greater than 500 lfm.

1. Input and output parameters vary 1:1 with V_{CC} . V_{EE} can vary +0.125 V to -1.3 V.
2. All loading with 50 Ω to $V_{CC} - 2.0\text{ V}$.
3. Do not use V_{BB} at $V_{CC} < 3.0\text{ V}$. Single ended input CLK pin operation is limited to $V_{CC} \geq 3.0\text{ V}$ in PECL mode.
4. V_{IHCMR} min varies 1:1 with V_{EE} , V_{IHCMR} max varies 1:1 with V_{CC} . The V_{IHCMR} range is referenced to the most positive side of the differential input signal.

Table 8. 100EP DC CHARACTERISTICS, PECL ($V_{CC} = 3.3\text{ V}$, $V_{EE} = 0\text{ V}$ (Note 1))

| Symbol | Characteristic | -40°C | | | 25°C | | | 85°C | | | Unit |
|-------------|--|-------------|------|------|-------------|------|------|-------------|------|------|---------------|
| | | Min | Typ | Max | Min | Typ | Max | Min | Typ | Max | |
| I_{EE} | Power Supply Current | 19 | 24 | 29 | 22 | 28 | 34 | 24 | 30 | 36 | mA |
| V_{OH} | Output HIGH Voltage (Note 2) | 2155 | 2280 | 2405 | 2155 | 2280 | 2405 | 2155 | 2280 | 2405 | mV |
| V_{OL} | Output LOW Voltage (Note 2) | 1355 | 1530 | 1700 | 1355 | 1530 | 1700 | 1355 | 1530 | 1700 | mV |
| V_{IH} | Input HIGH Voltage (Single Ended) | 2135 | | 2420 | 2135 | | 2420 | 2135 | | 2420 | mV |
| V_{IL} | Input LOW Voltage (Single Ended) | 1355 | | 1700 | 1355 | | 1700 | 1355 | | 1700 | mV |
| V_{BB} | Output Voltage Reference (Note 3) | 1775 | 1875 | 1975 | 1775 | 1875 | 1975 | 1775 | 1875 | 1975 | mV |
| V_{IHCMR} | Input HIGH Voltage Common Mode Range (Differential Configuration) (Note 4) | 1.2 | | 3.3 | 1.2 | | 3.3 | 1.2 | | 3.3 | V |
| I_{IH} | Input HIGH Current | | | 150 | | | 150 | | | 150 | μA |
| I_{IL} | Input LOW Current D \bar{D} | 0.5 -150 | | | 0.5 -150 | | | 0.5 -150 | | | μA |

NOTE: Device will meet the specifications after thermal equilibrium has been established when mounted in a test socket or printed circuit board with maintained transverse airflow greater than 500 lfm.

1. Input and output parameters vary 1:1 with V_{CC} . V_{EE} can vary +0.925 V to -0.5 V.
2. All loading with 50 Ω to $V_{CC} - 2.0\text{ V}$.
3. Single ended input CLK pin operation is limited to $V_{CC} \geq 3.0\text{ V}$ in PECL mode.
4. V_{IHCMR} min varies 1:1 with V_{EE} , V_{IHCMR} max varies 1:1 with V_{CC} . The V_{IHCMR} range is referenced to the most positive side of the differential input signal.

MC10LVEP16, MC100LVEP16

Table 9. 100EP DC CHARACTERISTICS, NECL ($V_{CC} = 0\text{ V}$, $V_{EE} = -3.8\text{ V}$ to -2.375 V (Note 1))

| Symbol | Characteristic | -40°C | | | 25°C | | | 85°C | | | Unit |
|-------------|--|--------------|-------|-------|--------------|-------|-------|--------------|-------|-------|---------------|
| | | Min | Typ | Max | Min | Typ | Max | Min | Typ | Max | |
| I_{EE} | Power Supply Current | 19 | 24 | 29 | 22 | 28 | 34 | 24 | 30 | 36 | mA |
| V_{OH} | Output HIGH Voltage (Note 2) | -1145 | -1020 | -895 | -1145 | -1020 | -895 | -1145 | -1020 | -895 | mV |
| V_{OL} | Output LOW Voltage (Note 2) | -1945 | -1770 | -1600 | -1945 | -1770 | -1600 | -1945 | -1770 | -1600 | mV |
| V_{IH} | Input HIGH Voltage (Single Ended) | -1165 | | -880 | -1165 | | -880 | -1165 | | -880 | mV |
| V_{IL} | Input LOW Voltage (Single Ended) | -1945 | | -1600 | -1945 | | -1600 | -1945 | | -1600 | mV |
| V_{BB} | Output Voltage Reference (Note 3) | -1525 | -1425 | -1325 | -1525 | -1425 | -1325 | -1525 | -1425 | -1325 | mV |
| V_{IHCMR} | Input HIGH Voltage Common Mode Range (Differential Configuration) (Note 4) | $V_{EE}+1.2$ | | 0.0 | $V_{EE}+1.2$ | | 0.0 | $V_{EE}+1.2$ | | 0.0 | V |
| I_{IH} | Input HIGH Current | | | 150 | | | 150 | | | 150 | μA |
| I_{IL} | Input LOW Current $\frac{D}{\bar{D}}$ | 0.5 -150 | | | 0.5 -150 | | | 0.5 -150 | | | μA |

NOTE: Device will meet the specifications after thermal equilibrium has been established when mounted in a test socket or printed circuit board with maintained transverse airflow greater than 500 lpm.

1. Input and output parameters vary 1:1 with V_{CC} .
2. All loading with $50\ \Omega$ to $V_{CC} - 2.0\text{ V}$.
3. Single ended input CLK pin operation is limited to $V_{EE} \leq -3.0\text{ V}$ in NECL mode.
4. V_{IHCMR} min varies 1:1 with V_{EE} , V_{IHCMR} max varies 1:1 with V_{CC} . The V_{IHCMR} range is referenced to the most positive side of the differential input signal.

Table 10. AC CHARACTERISTICS ($V_{CC} = 0\text{ V}$; $V_{EE} = -3.8\text{ V}$ to -2.375 V or $V_{CC} = 2.375\text{ V}$ to 3.8 V ; $V_{EE} = 0\text{ V}$ (Note 1))

| Symbol | Characteristic | -40°C | | | 25°C | | | 85°C | | | Unit |
|--------------------------|---|-------|--|--|------|--|--|------|--|--|------|
| | | Min | Typ | Max | Min | Typ | Max | Min | Typ | Max | |
| f_{max} | Maximum Frequency (See Figure 2. $F_{max}/JITTER$) | | > 4 | | | > 4 | | | > 4 | | GHz |
| t_{PLH} , t_{PHL} | Propagation Delay to Output Differential | 150 | 220 | 300 | 170 | 240 | 320 | 190 | 260 | 330 | ps |
| t_{SKEW} | Duty Cycle Skew (Note 2) | | 5.0 | 20 | | 5.0 | 20 | | 5.0 | 20 | ps |
| t_{JITTER} | CLOCK Random Jitter (RMS) @ $\leq 1.0\text{ GHz}$ @ $\leq 1.5\text{ GHz}$ @ $\leq 2.0\text{ GHz}$ @ $\leq 2.5\text{ GHz}$ @ $\leq 3.0\text{ GHz}$ @ $\leq 3.5\text{ GHz}$ | | 0.134 0.077 0.115 0.117 0.122 0.123 | 0.2 0.2 0.2 0.2 0.2 0.2 | | 0.147 0.104 0.141 0.132 0.143 0.145 | 0.3 0.3 0.3 0.3 0.3 0.3 | | 0.166 0.145 0.153 0.156 0.177 0.202 | 0.3 0.3 0.3 0.3 0.3 0.3 | ps |
| V_{PP} | Input Voltage Swing (Differential Configuration) | 150 | 800 | 1200 | 150 | 800 | 1200 | 150 | 800 | 1200 | mV |
| t_r , t_f | Output Rise/Fall Times (20% – 80%) Q, \bar{Q} | 70 | 120 | 170 | 80 | 130 | 180 | 100 | 150 | 200 | ps |

NOTE: Device will meet the specifications after thermal equilibrium has been established when mounted in a test socket or printed circuit board with maintained transverse airflow greater than 500 lpm.

1. Measured using a 750 mV source, 50% duty cycle clock source. All loading with $50\ \Omega$ to $V_{CC} - 2.0\text{ V}$.
2. Skew is measured between outputs under identical transitions. Duty cycle skew is defined only for differential operation when the delays are measured from the cross point of the inputs to the cross point of the outputs.

MC10LVEP16, MC100LVEP16

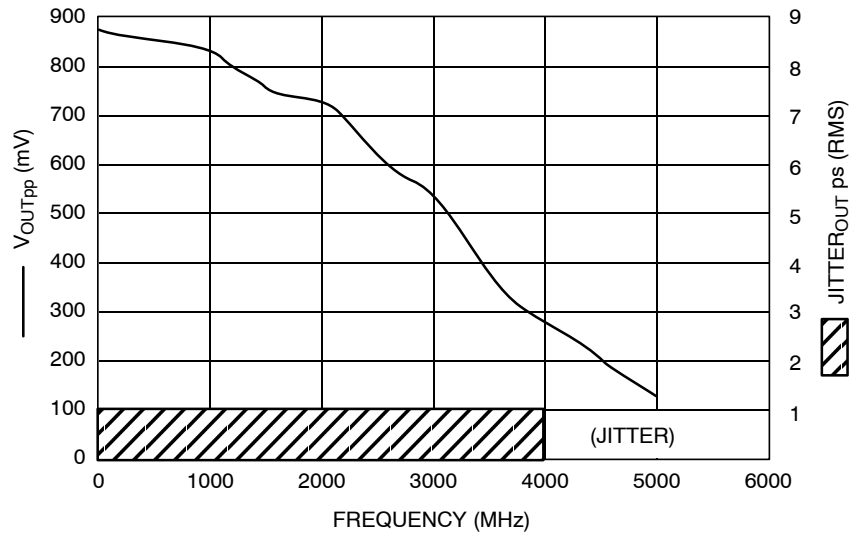

Figure 2. F_{max}/Jitter

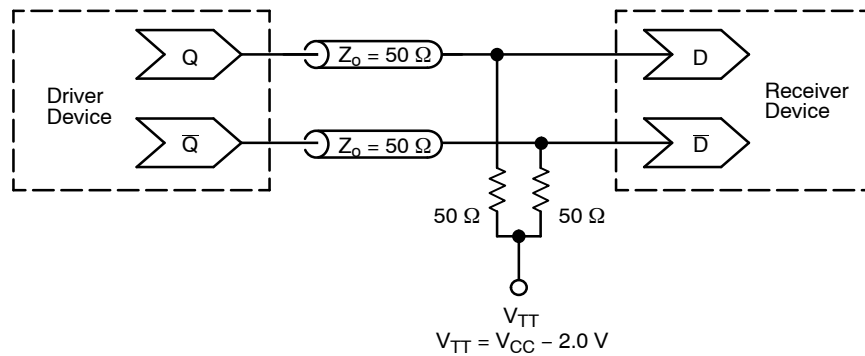

Figure 3. Typical Termination for Output Driver and Device Evaluation
(See Application Note [AND8020/D](#) – Termination of ECL Logic Devices)

ORDERING INFORMATION

| Device | Package | Shipping [†] |
|------------------|----------------------|-----------------------|
| MC10LVEP16DTR2G | TSSOP-8 (Pb-Free) | 2,500 / Tape & Reel |
| MC100LVEP16DTG | TSSOP-8 (Pb-Free) | 100 Units / Tube |
| MC100LVEP16DTR2G | TSSOP-8 (Pb-Free) | 2,500 / Tape & Reel |
| MC100LVEP16MNR4G | DFN8 (Pb-Free) | 1,000 / Tape & Reel |

DISCONTINUED (Note 3)

| | | |
|-----------------|------------------------|---------------------|
| MC100LVEP16DG | SOIC-8 NB (Pb-Free) | 98 Units / Tube |
| MC100LVEP16DR2G | SOIC-8 NB (Pb-Free) | 2,500 / Tape & Reel |

[†]For information on tape and reel specifications, including part orientation and tape sizes, please refer to our Tape and Reel Packaging Specifications Brochure, [BRD8011/D](#).

3. **DISCONTINUED:** These devices are not recommended for new design. Please contact your onsemi representative for information. The most current information on these devices may be available on www.onsemi.com.

MC10LVEP16, MC100LVEP16

Resource Reference of Application Notes

- AN1405/D** – ECL Clock Distribution Techniques
- AN1406/D** – Designing with PECL (ECL at +5.0 V)
- AN1503/D** – ECLinPS™ I/O SPiCE Modeling Kit
- AN1504/D** – Metastability and the ECLinPS Family
- AN1568/D** – Interfacing Between LVDS and ECL
- AN1672/D** – The ECL Translator Guide
- AND8001/D** – Odd Number Counters Design
- AND8002/D** – Marking and Date Codes
- AND8020/D** – Termination of ECL Logic Devices
- AND8066/D** – Interfacing with ECLinPS
- AND8090/D** – AC Characteristics of ECL Devices

ECLinPS is a trademark of Semiconductor Components Industries, LLC dba "onsemi" or its affiliates and/or subsidiaries in the United States and/or other countries.

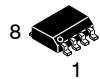

SCALE 1:1

SOIC-8 NB
CASE 751-07
ISSUE AK

DATE 16 FEB 2011

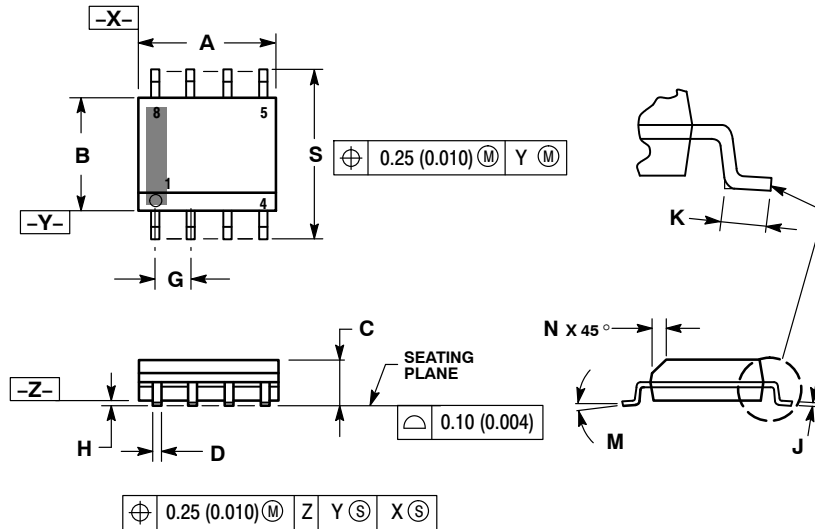

- NOTES:
1. DIMENSIONING AND TOLERANCING PER ANSI Y14.5M, 1982.
 2. CONTROLLING DIMENSION: MILLIMETER.
 3. DIMENSION A AND B DO NOT INCLUDE MOLD PROTRUSION.
 4. MAXIMUM MOLD PROTRUSION 0.15 (0.006) PER SIDE.
 5. DIMENSION D DOES NOT INCLUDE DAMBAR PROTRUSION. ALLOWABLE DAMBAR PROTRUSION SHALL BE 0.127 (0.005) TOTAL IN EXCESS OF THE D DIMENSION AT MAXIMUM MATERIAL CONDITION.
 6. 751-01 THRU 751-06 ARE OBSOLETE. NEW STANDARD IS 751-07.

| DIM | MILLIMETERS | | INCHES | |
|-----|-------------|------|-----------|-------|
| | MIN | MAX | MIN | MAX |
| A | 4.80 | 5.00 | 0.189 | 0.197 |
| B | 3.80 | 4.00 | 0.150 | 0.157 |
| C | 1.35 | 1.75 | 0.053 | 0.069 |
| D | 0.33 | 0.51 | 0.013 | 0.020 |
| G | 1.27 BSC | | 0.050 BSC | |
| H | 0.10 | 0.25 | 0.004 | 0.010 |
| J | 0.19 | 0.25 | 0.007 | 0.010 |
| K | 0.40 | 1.27 | 0.016 | 0.050 |
| M | 0° | 8° | 0° | 8° |
| N | 0.25 | 0.50 | 0.010 | 0.020 |
| S | 5.80 | 6.20 | 0.228 | 0.244 |

SOLDERING FOOTPRINT*

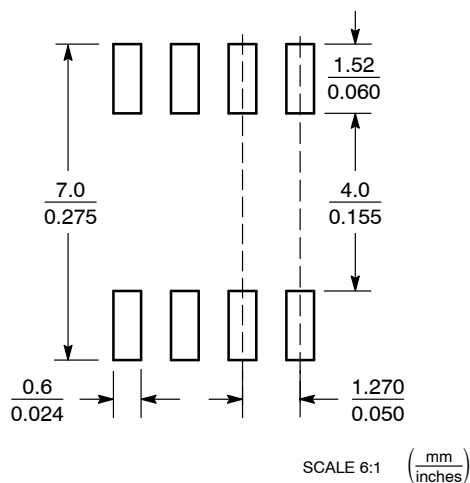

*For additional information on our Pb-Free strategy and soldering details, please download the onsemi Soldering and Mounting Techniques Reference Manual, SOLDERRM/D.

GENERIC MARKING DIAGRAM*

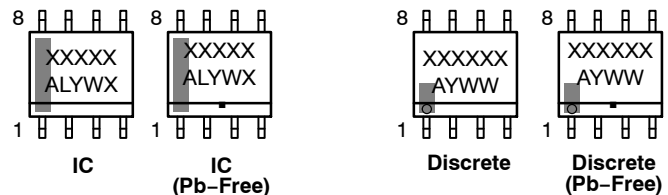

XXXXXX = Specific Device Code
A = Assembly Location
L = Wafer Lot
Y = Year
W = Work Week
▪ = Pb-Free Package

XXXXXX = Specific Device Code
A = Assembly Location
Y = Year
WW = Work Week
▪ = Pb-Free Package

*This information is generic. Please refer to device data sheet for actual part marking. Pb-Free indicator, "G" or microdot "▪", may or may not be present. Some products may not follow the Generic Marking.

STYLES ON PAGE 2

| | | |
|------------------|-------------|--|
| DOCUMENT NUMBER: | 98ASB42564B | Electronic versions are uncontrolled except when accessed directly from the Document Repository. Printed versions are uncontrolled except when stamped "CONTROLLED COPY" in red. |
| DESCRIPTION: | SOIC-8 NB | PAGE 1 OF 2 |

onsemi and onsemi are trademarks of Semiconductor Components Industries, LLC dba onsemi or its subsidiaries in the United States and/or other countries. onsemi reserves the right to make changes without further notice to any products herein. onsemi makes no warranty, representation or guarantee regarding the suitability of its products for any particular purpose, nor does onsemi assume any liability arising out of the application or use of any product or circuit, and specifically disclaims any and all liability, including without limitation special, consequential or incidental damages. onsemi does not convey any license under its patent rights nor the rights of others.

SOIC-8 NB
CASE 751-07
ISSUE AK

DATE 16 FEB 2011

- | | | | |
|---|--|--|--|
| <p>STYLE 1: PIN 1. EMITTER 2. COLLECTOR 3. COLLECTOR 4. EMITTER 5. EMITTER 6. BASE 7. BASE 8. EMITTER</p> | <p>STYLE 2: PIN 1. COLLECTOR, DIE, #1 2. COLLECTOR, #1 3. COLLECTOR, #2 4. COLLECTOR, #2 5. BASE, #2 6. EMITTER, #2 7. BASE, #1 8. EMITTER, #1</p> | <p>STYLE 3: PIN 1. DRAIN, DIE #1 2. DRAIN, #1 3. DRAIN, #2 4. DRAIN, #2 5. GATE, #2 6. SOURCE, #2 7. GATE, #1 8. SOURCE, #1</p> | <p>STYLE 4: PIN 1. ANODE 2. ANODE 3. ANODE 4. ANODE 5. ANODE 6. ANODE 7. ANODE 8. COMMON CATHODE</p> |
| <p>STYLE 5: PIN 1. DRAIN 2. DRAIN 3. DRAIN 4. DRAIN 5. GATE 6. GATE 7. SOURCE 8. SOURCE</p> | <p>STYLE 6: PIN 1. SOURCE 2. DRAIN 3. DRAIN 4. SOURCE 5. SOURCE 6. GATE 7. GATE 8. SOURCE</p> | <p>STYLE 7: PIN 1. INPUT 2. EXTERNAL BYPASS 3. THIRD STAGE SOURCE 4. GROUND 5. DRAIN 6. GATE 3 7. SECOND STAGE Vd 8. FIRST STAGE Vd</p> | <p>STYLE 8: PIN 1. COLLECTOR, DIE #1 2. BASE, #1 3. BASE, #2 4. COLLECTOR, #2 5. COLLECTOR, #2 6. EMITTER, #2 7. EMITTER, #1 8. COLLECTOR, #1</p> |
| <p>STYLE 9: PIN 1. EMITTER, COMMON 2. COLLECTOR, DIE #1 3. COLLECTOR, DIE #2 4. EMITTER, COMMON 5. EMITTER, COMMON 6. BASE, DIE #2 7. BASE, DIE #1 8. EMITTER, COMMON</p> | <p>STYLE 10: PIN 1. GROUND 2. BIAS 1 3. OUTPUT 4. GROUND 5. GROUND 6. BIAS 2 7. INPUT 8. GROUND</p> | <p>STYLE 11: PIN 1. SOURCE 1 2. GATE 1 3. SOURCE 2 4. GATE 2 5. DRAIN 2 6. DRAIN 2 7. DRAIN 1 8. DRAIN 1</p> | <p>STYLE 12: PIN 1. SOURCE 2. SOURCE 3. SOURCE 4. GATE 5. DRAIN 6. DRAIN 7. DRAIN 8. DRAIN</p> |
| <p>STYLE 13: PIN 1. N.C. 2. SOURCE 3. SOURCE 4. GATE 5. DRAIN 6. DRAIN 7. DRAIN 8. DRAIN</p> | <p>STYLE 14: PIN 1. N-SOURCE 2. N-GATE 3. P-SOURCE 4. P-GATE 5. P-DRAIN 6. P-DRAIN 7. N-DRAIN 8. N-DRAIN</p> | <p>STYLE 15: PIN 1. ANODE 1 2. ANODE 1 3. ANODE 1 4. ANODE 1 5. CATHODE, COMMON 6. CATHODE, COMMON 7. CATHODE, COMMON 8. CATHODE, COMMON</p> | <p>STYLE 16: PIN 1. EMITTER, DIE #1 2. BASE, DIE #1 3. EMITTER, DIE #2 4. BASE, DIE #2 5. COLLECTOR, DIE #2 6. COLLECTOR, DIE #2 7. COLLECTOR, DIE #1 8. COLLECTOR, DIE #1</p> |
| <p>STYLE 17: PIN 1. VCC 2. V2OUT 3. V1OUT 4. TXE 5. RXE 6. VEE 7. GND 8. ACC</p> | <p>STYLE 18: PIN 1. ANODE 2. ANODE 3. SOURCE 4. GATE 5. DRAIN 6. DRAIN 7. CATHODE 8. CATHODE</p> | <p>STYLE 19: PIN 1. SOURCE 1 2. GATE 1 3. SOURCE 2 4. GATE 2 5. DRAIN 2 6. MIRROR 2 7. DRAIN 1 8. MIRROR 1</p> | <p>STYLE 20: PIN 1. SOURCE (N) 2. GATE (N) 3. SOURCE (P) 4. GATE (P) 5. DRAIN 6. DRAIN 7. DRAIN 8. DRAIN</p> |
| <p>STYLE 21: PIN 1. CATHODE 1 2. CATHODE 2 3. CATHODE 3 4. CATHODE 4 5. CATHODE 5 6. COMMON ANODE 7. COMMON ANODE 8. CATHODE 6</p> | <p>STYLE 22: PIN 1. I/O LINE 1 2. COMMON CATHODE/VCC 3. COMMON CATHODE/VCC 4. I/O LINE 3 5. COMMON ANODE/GND 6. I/O LINE 4 7. I/O LINE 5 8. COMMON ANODE/GND</p> | <p>STYLE 23: PIN 1. LINE 1 IN 2. COMMON ANODE/GND 3. COMMON ANODE/GND 4. LINE 2 IN 5. LINE 2 OUT 6. COMMON ANODE/GND 7. COMMON ANODE/GND 8. LINE 1 OUT</p> | <p>STYLE 24: PIN 1. BASE 2. EMITTER 3. COLLECTOR/ANODE 4. COLLECTOR/ANODE 5. CATHODE 6. CATHODE 7. COLLECTOR/ANODE 8. COLLECTOR/ANODE</p> |
| <p>STYLE 25: PIN 1. VIN 2. N/C 3. REXT 4. GND 5. IOUT 6. IOUT 7. IOUT 8. IOUT</p> | <p>STYLE 26: PIN 1. GND 2. dv/dt 3. ENABLE 4. ILIMIT 5. SOURCE 6. SOURCE 7. SOURCE 8. VCC</p> | <p>STYLE 27: PIN 1. ILIMIT 2. OVLO 3. UVLO 4. INPUT+ 5. SOURCE 6. SOURCE 7. SOURCE 8. DRAIN</p> | <p>STYLE 28: PIN 1. SW_TO_GND 2. DASIC OFF 3. DASIC_SW_DET 4. GND 5. V_MON 6. VBULK 7. VBULK 8. VIN</p> |
| <p>STYLE 29: PIN 1. BASE, DIE #1 2. EMITTER, #1 3. BASE, #2 4. EMITTER, #2 5. COLLECTOR, #2 6. COLLECTOR, #2 7. COLLECTOR, #1 8. COLLECTOR, #1</p> | <p>STYLE 30: PIN 1. DRAIN 1 2. DRAIN 1 3. GATE 2 4. SOURCE 2 5. SOURCE 1/DRAIN 2 6. SOURCE 1/DRAIN 2 7. SOURCE 1/DRAIN 2 8. GATE 1</p> | | |

| | | |
|-------------------------|--------------------|---|
| DOCUMENT NUMBER: | 98ASB42564B | Electronic versions are uncontrolled except when accessed directly from the Document Repository. Printed versions are uncontrolled except when stamped "CONTROLLED COPY" in red. |
| DESCRIPTION: | SOIC-8 NB | PAGE 2 OF 2 |

onsemi and **ONSEMI** are trademarks of Semiconductor Components Industries, LLC dba **onsemi** or its subsidiaries in the United States and/or other countries. **onsemi** reserves the right to make changes without further notice to any products herein. **onsemi** makes no warranty, representation or guarantee regarding the suitability of its products for any particular purpose, nor does **onsemi** assume any liability arising out of the application or use of any product or circuit, and specifically disclaims any and all liability, including without limitation special, consequential or incidental damages. **onsemi** does not convey any license under its patent rights nor the rights of others.

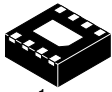

SCALE 4:1

DFN8 2x2, 0.5P
CASE 506AA
ISSUE F

DATE 04 MAY 2016

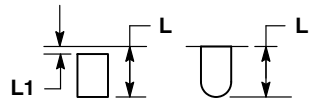
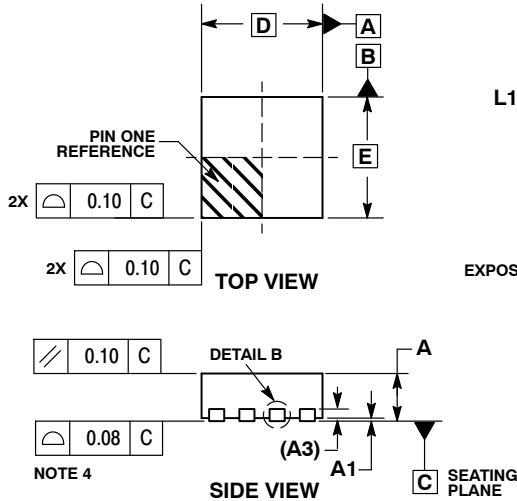

- NOTES:
1. DIMENSIONING AND TOLERANCING PER ASME Y14.5M, 1994 .
 2. CONTROLLING DIMENSION: MILLIMETERS.
 3. DIMENSION b APPLIES TO PLATED TERMINAL AND IS MEASURED BETWEEN 0.15 AND 0.20 MM FROM TERMINAL TIP.
 4. COPLANARITY APPLIES TO THE EXPOSED PAD AS WELL AS THE TERMINALS.

| DIM | MILLIMETERS | |
|-----|-------------|------|
| | MIN | MAX |
| A | 0.80 | 1.00 |
| A1 | 0.00 | 0.05 |
| A3 | 0.20 REF | |
| b | 0.20 | 0.30 |
| D | 2.00 BSC | |
| D2 | 1.10 | 1.30 |
| E | 2.00 BSC | |
| E2 | 0.70 | 0.90 |
| e | 0.50 BSC | |
| K | 0.30 REF | |
| L | 0.25 | 0.35 |
| L1 | --- | 0.10 |

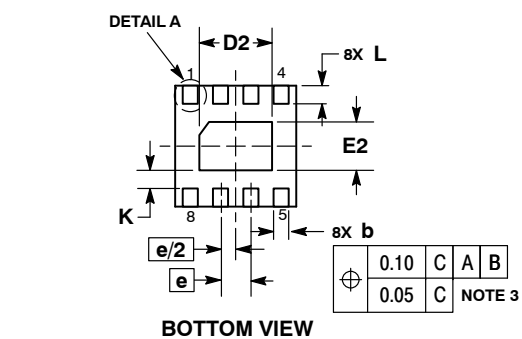

RECOMMENDED
SOLDERING FOOTPRINT*

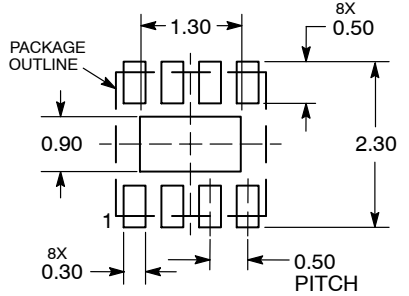

DIMENSIONS: MILLIMETERS

GENERIC
MARKING DIAGRAM*

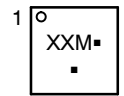

- XX = Specific Device Code
- M = Date Code
- = Pb-Free Device

*This information is generic. Please refer to device data sheet for actual part marking. Pb-Free indicator, "G" or microdot "▪", may or may not be present. Some products may not follow the Generic Marking.

*For additional information on our Pb-Free strategy and soldering details, please download the onsemi Soldering and Mounting Techniques Reference Manual, SOLDERRM/D.

| | | |
|------------------|----------------------------|--|
| DOCUMENT NUMBER: | 98AON18658D | Electronic versions are uncontrolled except when accessed directly from the Document Repository. Printed versions are uncontrolled except when stamped "CONTROLLED COPY" in red. |
| DESCRIPTION: | DFN8, 2.0X2.0, 0.5MM PITCH | PAGE 1 OF 1 |

onsemi and onsemi are trademarks of Semiconductor Components Industries, LLC dba onsemi or its subsidiaries in the United States and/or other countries. onsemi reserves the right to make changes without further notice to any products herein. onsemi makes no warranty, representation or guarantee regarding the suitability of its products for any particular purpose, nor does onsemi assume any liability arising out of the application or use of any product or circuit, and specifically disclaims any and all liability, including without limitation special, consequential or incidental damages. onsemi does not convey any license under its patent rights nor the rights of others.



SCALE 2:1

TSSOP-8 3.00x3.00x0.95
CASE 948R-02
ISSUE A

DATE 07 APR 2000

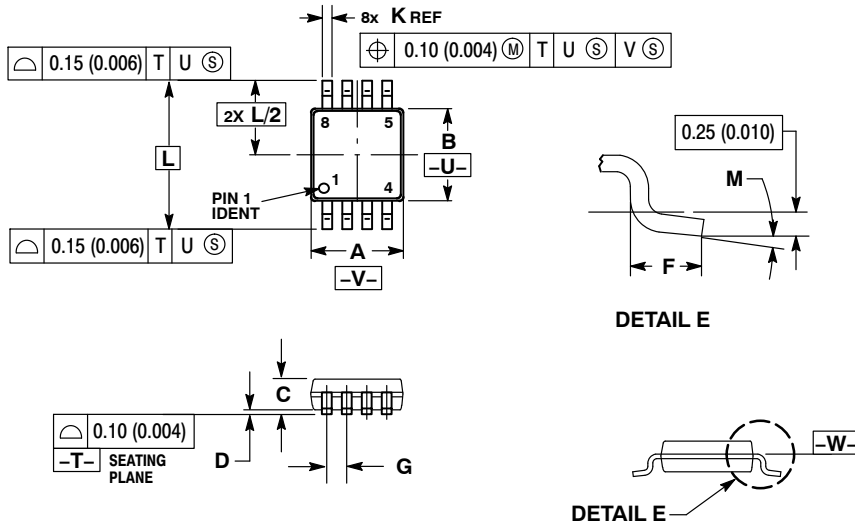

NOTES:

1. DIMENSIONING AND TOLERANCING PER ANSI Y14.5M, 1982.
2. CONTROLLING DIMENSION: MILLIMETER.
3. DIMENSION A DOES NOT INCLUDE MOLD FLASH. PROTRUSIONS OR GATE BURRS. MOLD FLASH OR GATE BURRS SHALL NOT EXCEED 0.15 (0.006) PER SIDE.
4. DIMENSION B DOES NOT INCLUDE INTERLEAD FLASH OR PROTRUSION. INTERLEAD FLASH OR PROTRUSION SHALL NOT EXCEED 0.25 (0.010) PER SIDE.
5. TERMINAL NUMBERS ARE SHOWN FOR REFERENCE ONLY.
6. DIMENSION A AND B ARE TO BE DETERMINED AT DATUM PLANE -W-.

| DIM | MILLIMETERS | | INCHES | |
|-----|-------------|------|-----------|-------|
| | MIN | MAX | MIN | MAX |
| A | 2.90 | 3.10 | 0.114 | 0.122 |
| B | 2.90 | 3.10 | 0.114 | 0.122 |
| C | 0.80 | 1.10 | 0.031 | 0.043 |
| D | 0.05 | 0.15 | 0.002 | 0.006 |
| F | 0.40 | 0.70 | 0.016 | 0.028 |
| G | 0.65 BSC | | 0.026 BSC | |
| K | 0.25 | 0.40 | 0.010 | 0.016 |
| L | 4.90 BSC | | 0.193 BSC | |
| M | 0° | 6° | 0° | 6° |

| | | |
|------------------|------------------------|--|
| DOCUMENT NUMBER: | 98AON00236D | Electronic versions are uncontrolled except when accessed directly from the Document Repository. Printed versions are uncontrolled except when stamped "CONTROLLED COPY" in red. |
| DESCRIPTION: | TSSOP-8 3.00x3.00x0.95 | PAGE 1 OF 1 |

onsemi and ONSEMI are trademarks of Semiconductor Components Industries, LLC dba onsemi or its subsidiaries in the United States and/or other countries. onsemi reserves the right to make changes without further notice to any products herein. onsemi makes no warranty, representation or guarantee regarding the suitability of its products for any particular purpose, nor does onsemi assume any liability arising out of the application or use of any product or circuit, and specifically disclaims any and all liability, including without limitation special, consequential or incidental damages. onsemi does not convey any license under its patent rights nor the rights of others.

onsemi, **Onsemi**, and other names, marks, and brands are registered and/or common law trademarks of Semiconductor Components Industries, LLC dba "**onsemi**" or its affiliates and/or subsidiaries in the United States and/or other countries. **onsemi** owns the rights to a number of patents, trademarks, copyrights, trade secrets, and other intellectual property. A listing of **onsemi**'s product/patent coverage may be accessed at www.onsemi.com/site/pdf/Patent-Marking.pdf. **onsemi** reserves the right to make changes at any time to any products or information herein, without notice. The information herein is provided "as-is" and **onsemi** makes no warranty, representation or guarantee regarding the accuracy of the information, product features, availability, functionality, or suitability of its products for any particular purpose, nor does **onsemi** assume any liability arising out of the application or use of any product or circuit, and specifically disclaims any and all liability, including without limitation special, consequential or incidental damages. Buyer is responsible for its products and applications using **onsemi** products, including compliance with all laws, regulations and safety requirements or standards, regardless of any support or applications information provided by **onsemi**. "Typical" parameters which may be provided in **onsemi** data sheets and/or specifications can and do vary in different applications and actual performance may vary over time. All operating parameters, including "Typicals" must be validated for each customer application by customer's technical experts. **onsemi** does not convey any license under any of its intellectual property rights nor the rights of others. **onsemi** products are not designed, intended, or authorized for use as a critical component in life support systems or any FDA Class 3 medical devices or medical devices with a same or similar classification in a foreign jurisdiction or any devices intended for implantation in the human body. Should Buyer purchase or use **onsemi** products for any such unintended or unauthorized application, Buyer shall indemnify and hold **onsemi** and its officers, employees, subsidiaries, affiliates, and distributors harmless against all claims, costs, damages, and expenses, and reasonable attorney fees arising out of, directly or indirectly, any claim of personal injury or death associated with such unintended or unauthorized use, even if such claim alleges that **onsemi** was negligent regarding the design or manufacture of the part. **onsemi** is an Equal Opportunity/Affirmative Action Employer. This literature is subject to all applicable copyright laws and is not for resale in any manner.

ADDITIONAL INFORMATION

TECHNICAL PUBLICATIONS:

Technical Library: www.onsemi.com/design/resources/technical-documentation
onsemi Website: www.onsemi.com

ONLINE SUPPORT: www.onsemi.com/support

For additional information, please contact your local Sales Representative at www.onsemi.com/support/sales