

# 2.5V / 3.3V 1:5 Differential ECL/PECL/HSTL Clock Driver

## MC100LVEP14

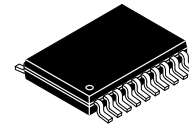

TSSOP-20  
DT SUFFIX  
CASE 948E

### Description

The MC100LVEP14 is a low skew 1-to-5 differential driver, designed with clock distribution in mind, accepting two clock sources into an input multiplexer. The ECL/PECL input signals can be either differential or single-ended (if the  $V_{BB}$  output is used). HSTL inputs can be used when the LVEP14 is operating under PECL conditions.

The LVEP14 specifically guarantees low output-to-output skew. Optimal design, layout, and processing minimize skew within a device and from device to device.

To ensure that the tight skew specification is realized, both sides of any differential output need to be terminated identically into 50  $\Omega$  even if only one output is being used. If an output pair is unused, both outputs may be left open (unterminated) without affecting skew.

The common enable ( $\overline{EN}$ ) is synchronous, outputs are enabled/disabled in the LOW state. This avoids a runt clock pulse when the device is enabled/disabled as can happen with an asynchronous control. The internal flip flop is clocked on the falling edge of the input clock; therefore, all associated specification limits are referenced to the negative edge of the clock input.

The MC100LVEP14, as with most other ECL devices, can be operated from a positive  $V_{CC}$  supply in PECL mode. This allows the LVEP14 to be used for high performance clock distribution in +3.3 V or +2.5 V systems. Single-ended CLK input pin operation is limited to a  $V_{CC} \geq 3.0$  V in PECL mode, or  $V_{EE} \leq -3.0$  V in NECL mode. Designers can take advantage of the LVEP14's performance to distribute low skew clocks across the backplane or the board.

### Features

- 100 ps Device-to-Device Skew
- 25 ps Within Device Skew
- 400 ps Typical Propagation Delay
- Maximum Frequency > 2 GHz Typical
- The 100 Series Contains Temperature Compensation
- PECL and HSTL Mode:  
 $V_{CC} = 2.375$  V to 3.8 V with  $V_{EE} = 0$  V
- NECL Mode:  
 $V_{CC} = 0$  V with  $V_{EE} = -2.375$  V to -3.8 V
- LVDS Input Compatible
- Open Input Default State
- These Devices are Pb-Free and are RoHS Compliant

### MARKING DIAGRAM

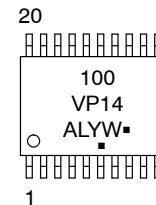

- A = Assembly Location
- L = Wafer Lot
- Y = Year
- W = Work Week
- = Pb-Free Package

(Note: Microdot may be in either location)

\*For additional marking information, refer to Application Note [AND8002/D](#).

### ORDERING INFORMATION

Device	Package	Shipping†
MC100LVEP14DTG	TSSOP-20 (Pb-Free)	75 Units / Tube
MC100LVEP14DTR2G	TSSOP-20 (Pb-Free)	2500 Tape & Reel

†For information on tape and reel specifications, including part orientation and tape sizes, please refer to our Tape and Reel Packaging Specifications Brochure, [BRD8011/D](#).

# MC100LVEP14

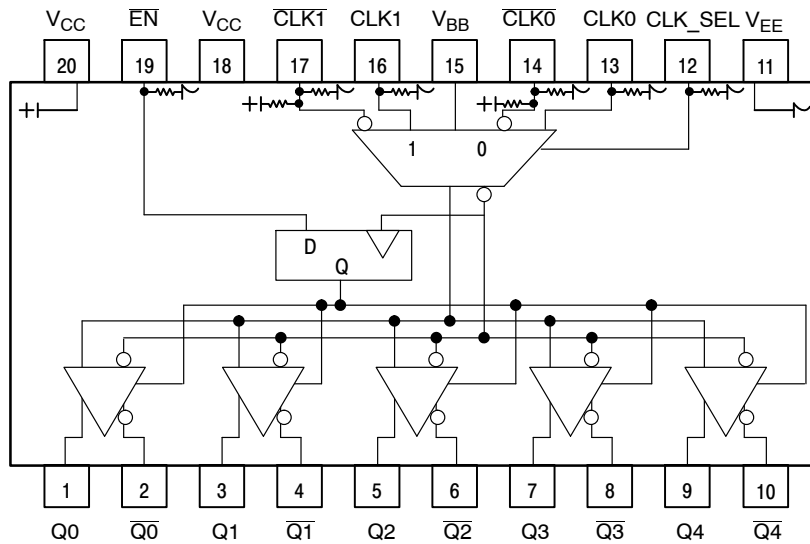

Warning: All  $V_{CC}$  and  $V_{EE}$  pins must be externally connected to Power Supply to guarantee proper operation.

**Figure 1. 20-Lead Pinout (Top View) and Logic Diagram**

**Table 1. PIN DESCRIPTION**

Pin	Type	Function
CLK0*, CLK0**	LVECL/LVPECL/ HSTL	ECL/PECL/HSTL CLK Input
CLK1*, CLK1**	LVECL/LVPECL/ HSTL	ECL/PECL/HSTL CLK Input
Q0:4, Q0:4	LVECL/LVPECL	ECL/PECL Outputs
CLK_SEL*	LVECL/LVPECL	ECL/PECL Active Clock Select Input
EN*	LVECL/LVPECL	ECL Sync Enable
V <sub>BB</sub>	LVECL/LVPECL	Reference Voltage Output
V <sub>CC</sub>		Positive Supply
V <sub>EE</sub>		Negative Supply

\* Pins will default low when left open.

\*\*Pins will default to  $V_{CC}/2$  when left open.

**Table 2. FUNCTION TABLE**

CLK0	CLK1	CLK_SEL	EN	Q
L	X	L	L	L
H	X	L	L	H
X	L	H	L	L
X	H	H	L	H
X	X	X	H	L*

\*On next negative transition of CLK0 or CLK1

**Table 3. ATTRIBUTES**

Characteristics		Value	
Internal Input Pulldown Resistor		75 kΩ	
Internal Input Pullup Resistor		37.5 kΩ	
ESD Protection	Human Body Model	> 2 kV	
	Machine Model	> 100 V	
	Charged Device Model	> 2 kV	
Moisture Sensitivity, Indefinite Time Out of Drypack (Note 1)	Pb Pkg	Level 1	
	Pb-Free Pkg	Level 1	
TSSOP-20		Level 1	
Flammability Rating	Oxygen Index: 28 to 34	UL 94 V-0 @ 0.125 in	
Transistor Count		357 Devices	
Meets or exceeds JEDEC Spec EIA/JESD78 IC Latchup Test			

1. For additional information, see Application Note AND8003/D.

# MC100LVEP14

**Table 4. MAXIMUM RATINGS**

Symbol	Parameter	Condition 1	Condition 2	Rating	Unit
V <sub>CC</sub>	PECL Mode Power Supply	V <sub>EE</sub> = 0 V		6	V
V <sub>EE</sub>	NECL Mode Power Supply	V <sub>CC</sub> = 0 V		-6	V
V <sub>I</sub>	PECL Mode Input Voltage NECL Mode Input Voltage	V <sub>EE</sub> = 0 V V <sub>CC</sub> = 0 V	V <sub>I</sub> ≤ V <sub>CC</sub> V <sub>I</sub> ≥ V <sub>EE</sub>	6 -6	V V
I <sub>out</sub>	Output Current	Continuous Surge		50 100	mA mA
I <sub>BB</sub>	V <sub>BB</sub> Sink/Source			± 0.5	mA
T <sub>A</sub>	Operating Temperature Range			-40 to +85	°C
T <sub>stg</sub>	Storage Temperature Range			-65 to +150	°C
θ <sub>JA</sub>	Thermal Resistance (Junction-to-Ambient)	0 lfpm 500 lfpm	TSSOP-20 TSSOP-20	140 100	°C/W °C/W
θ <sub>JC</sub>	Thermal Resistance (Junction-to-Case)	Standard Board	TSSOP-20	23 to 41	°C/W
T <sub>sol</sub>	Wave Solder Pb Pb-Free			265 265	°C

Stresses exceeding Maximum Ratings may damage the device. Maximum Ratings are stress ratings only. Functional operation above the Recommended Operating Conditions is not implied. Extended exposure to stresses above the Recommended Operating Conditions may affect device reliability.

**Table 5. 100LVEP DC CHARACTERISTICS, PECL V<sub>CC</sub> = 2.5 V, V<sub>EE</sub> = 0 V (Note 2)**

Symbol	Characteristic	-40°C			25°C			85°C			Unit
		Min	Typ	Max	Min	Typ	Max	Min	Typ	Max	
I <sub>EE</sub>	Power Supply Current	45	60	75	45	60	75	45	60	75	mA
V <sub>OH</sub>	Output HIGH Voltage (Note 3)	1355	1480	1605	1355	1480	1605	1355	1480	1605	mV
V <sub>OL</sub>	Output LOW Voltage (Note 3)	505	730	900	505	730	900	505	730	900	mV
V <sub>IH</sub>	Input HIGH Voltage (Single-Ended) (Note 4)	1335		1620	1335		1620	1275		1620	mV
V <sub>IL</sub>	Input LOW Voltage (Single-Ended) (Note 4)	505		900	505		900	505		900	mV
V <sub>IHCMR</sub>	Input HIGH Voltage Common Mode Range (Differential Configuration) (Note 5)	1.2		2.5	1.2		2.5	1.2		2.5	V
I <sub>IH</sub>	Input HIGH Current			150			150			150	μA
I <sub>IL</sub>	Input LOW Current	CLK CLK	0.5 -150		0.5 -150			0.5 -150			μA

NOTE: Device will meet the specifications after thermal equilibrium has been established when mounted in a test socket or printed circuit board with maintained transverse airflow greater than 500 lfpm. Electrical parameters are guaranteed only over the declared operating temperature range. Functional operation of the device exceeding these conditions is not implied. Device specification limit values are applied individually under normal operating conditions and not valid simultaneously.

- Input and output parameters vary 1:1 with V<sub>CC</sub>. V<sub>EE</sub> can vary +0.125 V to -1.3 V.
- All loading with 50 Ω to V<sub>CC</sub> - 2.0 V.
- Do not use V<sub>BB</sub> at V<sub>CC</sub> < 3.0 V.
- V<sub>IHCMR</sub> min varies 1:1 with V<sub>EE</sub>; V<sub>IHCMR</sub> max varies 1:1 with V<sub>CC</sub>. The V<sub>IHCMR</sub> range is referenced to the most positive side of the differential input signal.

# MC100LVEP14

**Table 6. 100LVEP DC CHARACTERISTICS, PECL**  $V_{CC} = 3.3\text{ V}$ ,  $V_{EE} = 0\text{ V}$  (Note 6)

Symbol	Characteristic	-40°C			25°C			85°C			Unit
		Min	Typ	Max	Min	Typ	Max	Min	Typ	Max	
$I_{EE}$	Power Supply Current	45	60	75	45	60	75	45	60	75	mA
$V_{OH}$	Output HIGH Voltage (Note 7)	2155	2280	2405	2155	2280	2405	2155	2280	2405	mV
$V_{OL}$	Output LOW Voltage (Note 7)	1305	1530	1700	1305	1530	1700	1305	1530	1700	mV
$V_{IH}$	Input HIGH Voltage (Single-Ended)	2135		2420	2135		2420	2135		2420	mV
$V_{IL}$	Input LOW Voltage (Single-Ended)	1305		1700	1305		1700	1305		1700	mV
$V_{BB}$	Output Reference Voltage (Note 8)	1775	1875	1975	1775	1875	1975	1775	1875	1975	mV
$V_{IHCMR}$	Input HIGH Voltage Common Mode Range (Differential Configuration) (Note 9)	1.2		3.3	1.2		3.3	1.2		3.3	V
$I_{IH}$	Input HIGH Current			150			150			150	$\mu\text{A}$
$I_{IL}$	Input LOW Current	CLK CLK	0.5 -150		0.5 -150			0.5 -150			$\mu\text{A}$

NOTE: Device will meet the specifications after thermal equilibrium has been established when mounted in a test socket or printed circuit board with maintained transverse airflow greater than 500 lpm. Electrical parameters are guaranteed only over the declared operating temperature range. Functional operation of the device exceeding these conditions is not implied. Device specification limit values are applied individually under normal operating conditions and not valid simultaneously.

6. Input and output parameters vary 1:1 with  $V_{CC}$ .  $V_{EE}$  can vary +0.925 V to -0.5 V.
7. All loading with 50  $\Omega$  to  $V_{CC} - 2.0\text{ V}$ .
8. Single-ended input operation is limited to  $V_{CC} \geq 3.0\text{ V}$  in PECL mode.
9.  $V_{IHCMR}$  min varies 1:1 with  $V_{EE}$ ,  $V_{IHCMR}$  max varies 1:1 with  $V_{CC}$ . The  $V_{IHCMR}$  range is referenced to the most positive side of the differential input signal.

**Table 7. 100LVEP DC CHARACTERISTICS, NECL**  $V_{CC} = 0\text{ V}$ ,  $V_{EE} = -3.8\text{ V}$  to  $-2.375\text{ V}$  (Note 10)

Symbol	Characteristic	-40°C			25°C			85°C			Unit
		Min	Typ	Max	Min	Typ	Max	Min	Typ	Max	
$I_{EE}$	Power Supply Current	45	60	75	45	60	75	45	60	75	mA
$V_{OH}$	Output HIGH Voltage (Note 11)	-1145	-1020	-895	-1145	-1020	-895	-1145	-1020	-895	mV
$V_{OL}$	Output LOW Voltage (Note 11)	-1995	-1770	-1600	-1995	-1770	-1600	-1995	-1770	-1600	mV
$V_{IH}$	Input HIGH Voltage (Single-Ended)	-1165		-880	-1165		-880	-1165		-880	mV
$V_{IL}$	Input LOW Voltage (Single-Ended)	-1995		-1600	-1995		-1600	-1995		-1600	mV
$V_{BB}$	Output Reference Voltage (Note 12)	-1525	-1425	-1325	-1525	-1425	-1325	-1525	-1425	-1325	mV
$V_{IHCMR}$	Input HIGH Voltage Common Mode Range (Differential Configuration) (Note 13)	$V_{EE} + 1.2$		0.0	$V_{EE} + 1.2$		0.0	$V_{EE} + 1.2$		0.0	V
$I_{IH}$	Input HIGH Current			150			150			150	$\mu\text{A}$
$I_{IL}$	Input LOW Current	CLK CLK	0.5 -150		0.5 -150			0.5 -150			$\mu\text{A}$

NOTE: Device will meet the specifications after thermal equilibrium has been established when mounted in a test socket or printed circuit board with maintained transverse airflow greater than 500 lpm. Electrical parameters are guaranteed only over the declared operating temperature range. Functional operation of the device exceeding these conditions is not implied. Device specification limit values are applied individually under normal operating conditions and not valid simultaneously.

10. Input and output parameters vary 1:1 with  $V_{CC}$ .
11. All loading with 50  $\Omega$  to  $V_{CC} - 2.0\text{ V}$ .
12. Single-ended input operation is limited to  $V_{EE} \leq 3.0\text{ V}$  in NECL mode.
13.  $V_{IHCMR}$  min varies 1:1 with  $V_{EE}$ ,  $V_{IHCMR}$  max varies 1:1 with  $V_{CC}$ . The  $V_{IHCMR}$  range is referenced to the most positive side of the differential input signal.

# MC100LVEP14

**Table 8. DC CHARACTERISTICS, HSTL**  $V_{CC} = 2.375\text{ V to }3.8\text{ V}$ ,  $V_{EE} = 0\text{ V}$

Symbol	Characteristic	-40°C			25°C			85°C			Unit
		Min	Typ	Max	Min	Typ	Max	Min	Typ	Max	
$V_{IH}$	Input HIGH Voltage	1200			1200			1200			mV
$V_{IL}$	Input LOW Voltage			400			400			400	mV

NOTE: Device will meet the specifications after thermal equilibrium has been established when mounted in a test socket or printed circuit board with maintained transverse airflow greater than 500 lfm. Electrical parameters are guaranteed only over the declared operating temperature range. Functional operation of the device exceeding these conditions is not implied. Device specification limit values are applied individually under normal operating conditions and not valid simultaneously.

**Table 9. AC CHARACTERISTICS**  $V_{CC} = 0\text{ V}$ ,  $V_{EE} = -2.375\text{ V to }-3.8\text{ V}$  or  $V_{CC} = 2.375\text{ V to }3.8\text{ V}$ ;  $V_{EE} = 0\text{ V}$  (Note 14)

Symbol	Characteristic	-40°C			25°C			85°C			Unit
		Min	Typ	Max	Min	Typ	Max	Min	Typ	Max	
$V_{OUTPP}$	Output Voltage Amplitude @ 2.5 GHz (Figure 2)	330	425		280	375		230	295		mV
$t_{PLH}$ $t_{PHL}$	Propagation Delay to Output Differential	300	375	425	300	400	475	300	430	525	ps
$t_{skew}$	Within-Device Skew (Note 15) Device-to-Device Skew (Note 15)		10 100	25 125		15 150	25 175		15 200	25 225	ps
$t_s$ $t_h$	Setup Time Hold Time	EN EN	100 200	50 140	100 200	50 140		100 200	50 140		ps
$t_{JITTER}$	CLOCK Random Jitter (RMS) @ $\leq 1.0\text{ GHz}$ @ $\leq 1.5\text{ GHz}$ @ $\leq 2.0\text{ GHz}$ @ $\leq 2.5\text{ GHz}$		0.157 0.163 0.180 0.179	0.3 0.2 0.3 0.3		0.181 0.176 0.201 0.208	0.3 0.3 0.3 0.3		0.212 0.218 0.235 0.253	0.3 0.3 0.3 0.4	ps
$V_{PP}$	Minimum Input Swing	150	800	1200	150	800	1200	150	800	1200	mV
$t_r/t_f$	Output Rise/Fall Time (20%–80%)	125	165	225	125	180	250	125	200	275	ps

NOTE: Device will meet the specifications after thermal equilibrium has been established when mounted in a test socket or printed circuit board with maintained transverse airflow greater than 500 lfm. Electrical parameters are guaranteed only over the declared operating temperature range. Functional operation of the device exceeding these conditions is not implied. Device specification limit values are applied individually under normal operating conditions and not valid simultaneously.

14. Measured using a 750 mV source, 50% duty cycle clock source. All loading with  $50\ \Omega$  to  $V_{CC} - 2.0\text{ V}$ .

15. Skew is measured between outputs under identical transitions.

## Resource Reference of Application Notes

- AN1405/D** – ECL Clock Distribution Techniques
- AN1406/D** – Designing with PECL (ECL at +5.0 V)
- AN1503/D** – ECLinPS™ I/O SPICE Modeling Kit
- AN1504/D** – Metastability and the ECLinPS Family
- AN1568/D** – Interfacing Between LVDS and ECL
- AN1672/D** – The ECL Translator Guide
- AND8001/D** – Odd Number Counters Design
- AND8002/D** – Marking and Date Codes
- AND8020/D** – Termination of ECL Logic Devices
- AND8066/D** – Interfacing with ECLinPS
- AND8090/D** – AC Characteristics of ECL Devices

# MC100LVEP14

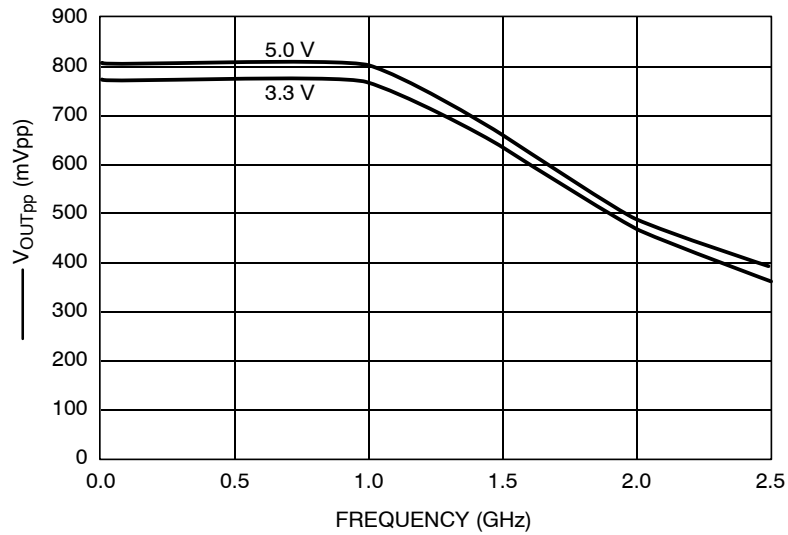

Figure 2. Typical V<sub>OUTpp</sub> (mVpp) versus Frequency (GHz) @ 25°C

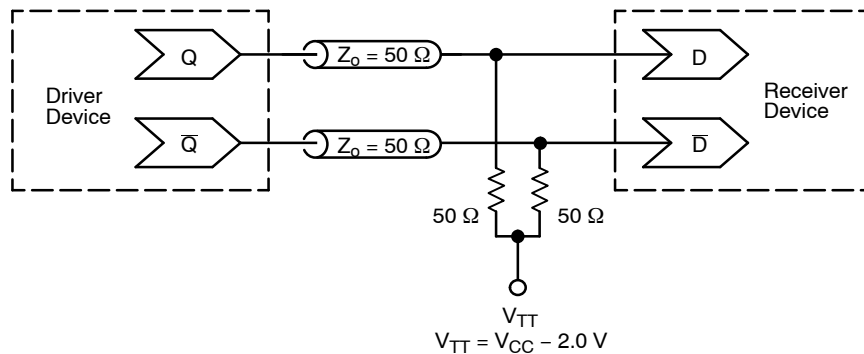

Figure 3. Typical Termination for Output Driver and Device Evaluation (See Application Note AND8020/D – Termination of ECL Logic Devices.)

ECLinPS is registered trademark of Semiconductor Components Industries, LLC dba “onsemi” or its affiliates and/or subsidiaries in the United States and/or other countries.

**onsemi**, **Onsemi**, and other names, marks, and brands are registered and/or common law trademarks of Semiconductor Components Industries, LLC dba "**onsemi**" or its affiliates and/or subsidiaries in the United States and/or other countries. **onsemi** owns the rights to a number of patents, trademarks, copyrights, trade secrets, and other intellectual property. A listing of **onsemi**'s product/patent coverage may be accessed at [www.onsemi.com/site/pdf/Patent-Marking.pdf](http://www.onsemi.com/site/pdf/Patent-Marking.pdf). **onsemi** reserves the right to make changes at any time to any products or information herein, without notice. The information herein is provided "as-is" and **onsemi** makes no warranty, representation or guarantee regarding the accuracy of the information, product features, availability, functionality, or suitability of its products for any particular purpose, nor does **onsemi** assume any liability arising out of the application or use of any product or circuit, and specifically disclaims any and all liability, including without limitation special, consequential or incidental damages. Buyer is responsible for its products and applications using **onsemi** products, including compliance with all laws, regulations and safety requirements or standards, regardless of any support or applications information provided by **onsemi**. "Typical" parameters which may be provided in **onsemi** data sheets and/or specifications can and do vary in different applications and actual performance may vary over time. All operating parameters, including "Typicals" must be validated for each customer application by customer's technical experts. **onsemi** does not convey any license under any of its intellectual property rights nor the rights of others. **onsemi** products are not designed, intended, or authorized for use as a critical component in life support systems or any FDA Class 3 medical devices or medical devices with a same or similar classification in a foreign jurisdiction or any devices intended for implantation in the human body. Should Buyer purchase or use **onsemi** products for any such unintended or unauthorized application, Buyer shall indemnify and hold **onsemi** and its officers, employees, subsidiaries, affiliates, and distributors harmless against all claims, costs, damages, and expenses, and reasonable attorney fees arising out of, directly or indirectly, any claim of personal injury or death associated with such unintended or unauthorized use, even if such claim alleges that **onsemi** was negligent regarding the design or manufacture of the part. **onsemi** is an Equal Opportunity/Affirmative Action Employer. This literature is subject to all applicable copyright laws and is not for resale in any manner.

## ADDITIONAL INFORMATION

### TECHNICAL PUBLICATIONS:

Technical Library: [www.onsemi.com/design/resources/technical-documentation](http://www.onsemi.com/design/resources/technical-documentation)  
onsemi Website: [www.onsemi.com](http://www.onsemi.com)

### ONLINE SUPPORT: [www.onsemi.com/support](http://www.onsemi.com/support)

For additional information, please contact your local Sales Representative at [www.onsemi.com/support/sales](http://www.onsemi.com/support/sales)

