

# 4:1 High-Speed USB Multiplexer/Switch

## FSUSB74

### Description

The FSUSB74 is a Bi-directional, Low-Power, High-Speed USB 2.0 4:1 MUX. It is Optimized for Switching from four High-Speed (480Mbps) sources or any combination of High-Speed and full-/low-speed USB/UART sources to one USB 2.0 connector.

### Applications

- MP3 Portable Media Players
- Cellular Phones, Smart Phones
- Netbooks, Mobile Internet Devices (MID)

### Related Resources

- FSUSB74 Demonstration Board
- FSUSB74 Evaluation Board

### Features

Switch Type	4:1
USB	USB 2.0 High-Speed Compliant USB 2.0 Full-Speed Compliant
R <sub>ON</sub>	6.5 Ω
C <sub>ON</sub>	7.5 pF
ESD (IEC61000-4-2)	15 kV (Air) 8 kV (Contact)
V <sub>CC</sub>	2.7 to 4.4 V
I <sub>CCSLP</sub>	<1 μA
I <sub>CCACT</sub>	9 μA
Package	16-Lead UMLP 1.80 x 2.60 x 0.55mm, 0.40mm Pitch 16-Lead MLP 3 x 3 x 0.7mm, 0.5mm Pitch
Ordering Information	FSUSB74UMX (UMLP) FSUSB74MPX (MLP)

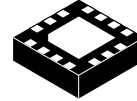

WQFN 16 3X3, 0.5P  
CASE 510BS

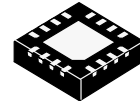

UQFN 16 1.8X2.6, 0.6P  
CASE 523BF

### MARKING DIAGRAM

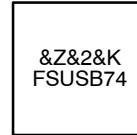

LC,FSUSB74 = Device Code  
 &Z = Assembly Plant Code  
 &2 = 2-Digit Date Code  
 &K = 2-Digits Lot Run Lot Traceability Code  
 FSUSB74 = Specific Device Code

### ORDERING INFORMATION

Device	Package	Shipping <sup>†</sup>
FSUSB74MPX	WQFN-16 (Pb-Free)	3000 / Tape & Reel
FSUSB74UMX	UQFN-16 (Pb-Free)	3000 / Tape & Reel

<sup>†</sup>For information on tape and reel specifications, including part orientation and tape sizes, please refer to our Tape and Reel Packaging Specifications Brochure, [BRD8011/D](#).

# FSUSB74

## TYPICAL APPLICATION

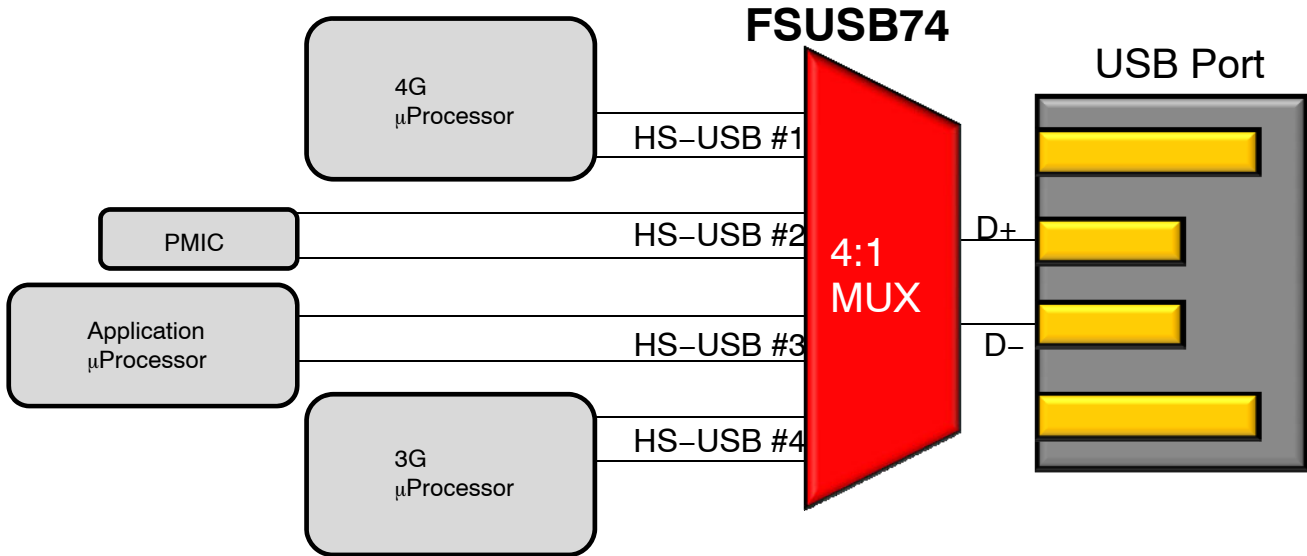

Figure 1. Mobile Phone Example

## PIN CONFIGURATIONS

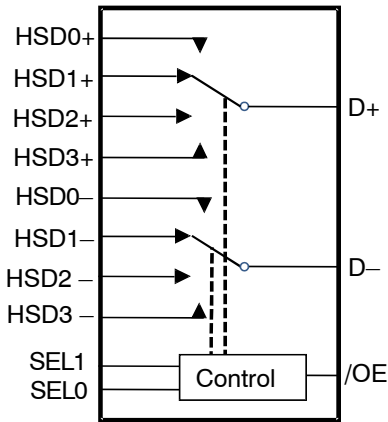

Figure 2. UMLP Analog Symbol

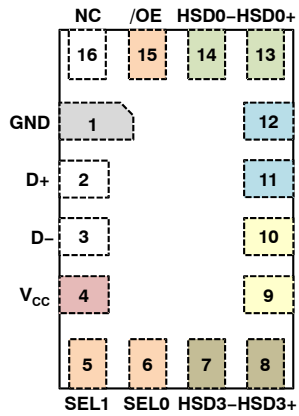

Figure 3. UMLP (Top View)

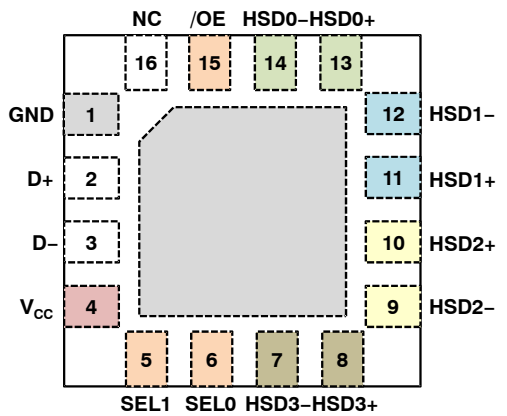

Figure 4. MLP (Top View)

# FSUSB74

## PIN DESCRIPTIONS

Pin No.	Name	Type	Description
1	GND	Ground	Ground
2	D+	I/O	D+ common port (HS or FS USB)
3	D-	I/O	D- common port (HS or FS USB)
4	V <sub>CC</sub>	Power Supply	Supply Voltage
5	SEL1	Input	Path Selection Control Input (see truth table below)
6	SEL0	Input	Path Selection Control Input (see truth table below)
7	HSD3-	I/O	D- from fourth source path (HS or FS USB)
8	HSD3+	I/O	D+ from fourth source path (HS or FS USB)
9	HSD2-	I/O	D- from third source path (HS or FS USB)
10	HSD2+	I/O	D+ from third source path (HS or FS USB)
11	HSD1+	I/O	D+ from second source path (HS or FS USB)
12	HSD1-	I/O	D- from second source path (HS or FS USB)
13	HSD0+	I/O	D+ from first source path (HS or FS USB)
14	HSD0-	I/O	D- from first source path (HS or FS USB)
15	/OE	Input	D- from first source path (HS or FS USB)
16	NC	-	No Connect

## TRUTH TABLE

/OE	SEL1	SEL0	Function
1	X	X	D+, D- Switch Paths Open
0	0	0	D+ = HSD0+, D- = HSD0-
0	0	1	D+ = HSD1+, D- = HSD1-
0	1	0	D+ = HSD2+, D- = HSD2-
0	1	1	D+ = HSD3+, D- = HSD3-

## ABSOLUTE MAXIMUM RATINGS

Symbol	Parameter	Min.	Max.	Unit	
V <sub>CC</sub>	Supply Voltage	-0.5	5.25	V	
V <sub>CNTRL</sub>	DC Input Voltage (SEL1, SEL0, /OE, SELS) <sup>(1)</sup>	-0.50	V <sub>CC</sub>	V	
V <sub>SW</sub>	DC Switch I/O Voltage <sup>(1)</sup>	-0.50	5.25	V	
I <sub>IK</sub>	DC Input Diode Current	-50	-	mA	
T <sub>STG</sub>	Storage Temperature	-65	+150	°C	
MSL	Moisture Sensitivity Level (JEDEC J-STD-020A)	-	1	Level	
ESD	IEC61000-4-2 System on USB connector pins D+ & D-	Air Gap	15	-	kV
		Contact	8	-	
	Human Body Model, JEDEC: JESD22-A114	D+,D- to GND	6	-	
		Power to GND	12	-	
		All Other Pins	2	-	

Stresses exceeding those listed in the Maximum Ratings table may damage the device. If any of these limits are exceeded, device functionality should not be assumed, damage may occur and reliability may be affected.

1. The input and output negative ratings may be exceeded if the input and output diode current ratings are observed.

# FSUSB74

## RECOMMENDED OPERATING CONDITIONS

Symbol	Parameter	Min.	Max.	Unit
$V_{CC}$	Supply Voltage	2.5	4.4	V
$V_{CNTRL}$ (Note 2)	Control Input Voltage (SEL1, SEL0, /OE, and SELS)	0	$V_{CC}$	V
$V_{SW}$	Switch I/O Voltage	-0.5	4.4	V
$T_A$	Operating Temperature	-40	+85	°C

Functional operation above the stresses listed in the Recommended Operating Ranges is not implied. Extended exposure to stresses beyond the Recommended Operating Ranges limits may affect device reliability.

2. The control input must be held HIGH or LOW; it must not float.

## DC ELECTRICAL CHARACTERISTICS (All typical values are for $V_{CC} = 3.3$ V at $25^\circ\text{C}$ unless otherwise specified.)

Symbol	Parameter	Test Conditions	$V_{CC}$ (V)	$T_A = -40^\circ\text{C to } 85^\circ\text{C}$			Unit
				Min.	Typ.	Max.	
$R_{ON}$ (Note 3)	HS Switch On Resistance	$V_{SW} = 0.4$ V, $I_{ON} = -8$ mA, Figure 5	3.3		6.5	9.0	$\Omega$
$\Delta R_{ON}$ (Note 3)	HS Delta Ron (Note 4)	$V_{SW} = 0.4$ V, $I_{ON} = -8$ mA	3.3		0.5	0.5	$\Omega$
$I_{IN}$	Control Input Leakage	All Combinations of /OE, SEL1 & SEL0 in the Truth Table ( $1 = V_{CC}$ , $0 = 0$ V)	4.4	-1	-	-	$\mu\text{A}$
$I_{OZ}$	Off State Leakage	$0 \leq D_n$ , HSD0n, HSD1n, HSD2n, HSD3n $\leq 4.4$ V	4.4	-1	-	-	$\mu\text{A}$
$I_{OFF}$	Power-Off Leakage Current (All I/O Ports)	$V_{SW} = 0$ V to 4.4 V, $V_{CC} = 0$ V, Figure 6	0	-1	-	-	$\mu\text{A}$
$I_{CCSLP}$	Sleep Mode Supply Current	/OE = $V_{CC}$	4.4	-	-	-	$\mu\text{A}$
$I_{CCACT}$	Active Mode Supply Current	All Active Modes in Truth Table	4.4	-	9	18	$\mu\text{A}$
$I_{CCT}$	Increase in $I_{CC}$ Current per Control Input and $V_{CC}$	$V_{CNTRL} = 1.8$ V	4.4	-	3.3	4.0	$\mu\text{A}$
		$V_{CNTRL} = 1.2$ V	4.4	-	4.9	6.0	$\mu\text{A}$
$V_{IK}$	Clamp Diode Voltage	$I_{IN} = -18$ mA	2.5	-	-	-1.2	V
$V_{IH}$	Control Input Voltage High	SEL1, SEL0, /OE	2.5 to 4.4	1.0	-	-	V
$V_{IL}$	Control Input Voltage Low	SEL1, SEL0, /OE	2.5 to 4.4	-	-	0.35	V

3. Measured by the voltage drop between HSDn and Dn pins at the indicated current through the switch. On resistance is determined by the lower of the voltage on the two (HSDn or Dn ports).

4. Guaranteed by characterization.

## AC ELECTRICAL CHARACTERISTICS (All typical values are for $V_{CC} = 3.3$ V at $T_A = 25^\circ\text{C}$ unless otherwise specified.)

Symbol	Parameter	Test Conditions	$V_{CC}$ (V)	$T_A = -40^\circ\text{C to } 85^\circ\text{C}$			Unit
				Min.	Typ.	Max.	
$t_{ON}$	Turn-On Time when Switching from One USB Path (or Disabled i.e. /OE=1) to Another USB Path	$R_L = 50$ $\Omega$ , $C_L = 35$ pF, $V_{SW} = 0.8$ V, Figure 7, Figure 8	2.5 to 4.4	126	-	400	$\mu\text{s}$
$t_{OFF}$	Turn-Off Time, Turning Off Any of the USB Paths	$R_L = 50$ $\Omega$ , $C_L = 35$ pF, $V_{SW} = 0.8$ V, Figure 7, Figure 8	2.5 to 4.4	-	-	80	ns
$t_{PD}$	Propagation Delay (Note 5)	$C_L = 5$ pF, $R_L = 50$ $\Omega$ , Figure 7, Figure 9	3.3	-	0.25	-	ns
$t_{RF}$	Slow Turn-On/Off Switch Paths (Note 5)	$C_L = 5$ pF, Dn at 0 V or 3.6 V, 40.5 $\Omega$ in series with switch 10% to 90%	3.3	-	4.5	-	ns
$t_{BBM}$	Break-Before-Make Time (Note 5)	$R_L = 50$ $\Omega$ , $C_L = 35$ pF, $V_{SW1} = V_{SW2} = 0.8$ V, Figure 11	2.5 to 4.4	126	-	400	$\mu\text{s}$
$O_{IRR}$	Off Isolation (Note 5)	$R_L = 50$ $\Omega$ , $f = 240$ MHz, Figure 13	2.5 to 4.4	-	-40	-	dB
$X_{talk}$	Channel-to-Channel Crosstalk (Note 5)	$R_L = 50$ $\Omega$ , $f = 240$ MHz, Figure 14	2.5 to 4.4	-	-40	-	dB
$t_{SK(P)}$	Pulse Skew (Note 5)	$V_{SW} = 0.2$ V diff <sub>PP</sub> , Figure 10, $C_L = 5$ pF	2.5 to 4.4	-	25	-	ps
$t_{SK(I)}$	Skew Between Differential Signals Within a Pair (Note 5)	$V_{SW} = 0.2$ V diff <sub>PP</sub> , Figure 10, $C_L = 5$ pF	2.5 to 4.4	-	25	-	ps

5. Guaranteed by characterization.

# FSUSB74

## CAPACITANCE CHARACTERISTICS (All typical values are for $V_{CC} = 3.3\text{ V}$ at $T_A = 25^\circ\text{C}$ unless otherwise specified.)

Symbol	Parameter	Test Conditions	$V_{CC}$ (V)	Typical	Unit
$C_{IN}$	Input Capacitance (Note 6)		0	3	pF
$C_{ON}$	D+/D- On Capacitance (Note 6)	Any Switch Path Enabled, $f = 1\text{MHz}$ , Figure 16	3.3	7.5	
$C_{OFF}$	HSD0n, HSD1n, HSD2n, HSD3n Off Capacitance (Note 6)	If $V_{CC} = 3.3\text{ V}$ , then $/OE = 3.3\text{ V}$ ; $f = 1\text{MHz}$ , Figure 15	0 or 3.3	2.2	

6. Guaranteed by characterization.

TEST DIAGRAMS

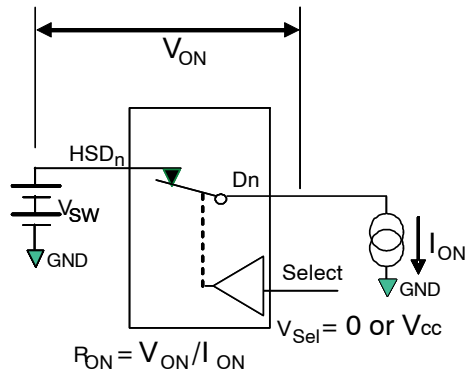
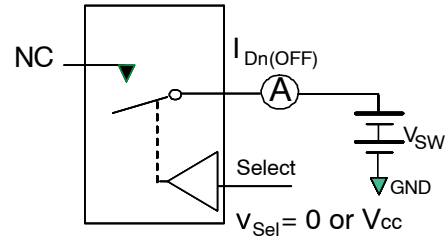

Figure 5. On Resistance



\*\*Each switch port is tested separately

Figure 6. Off Leakage

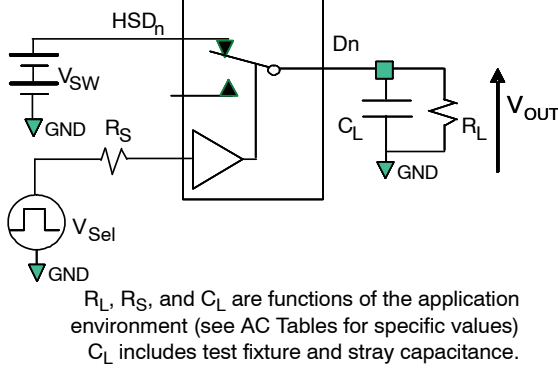

Figure 7. AC Test Circuit Load

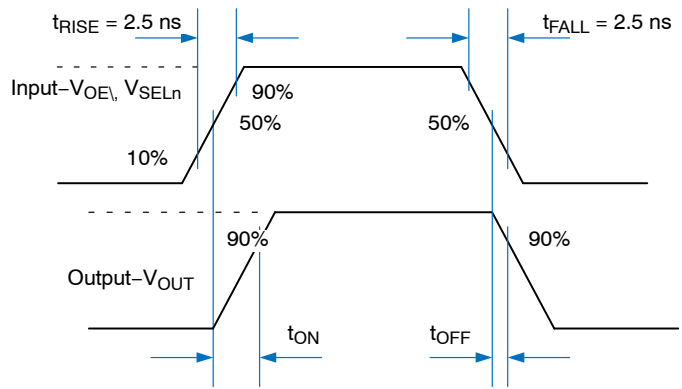

Figure 8. Turn-On / Turn-Off Waveforms

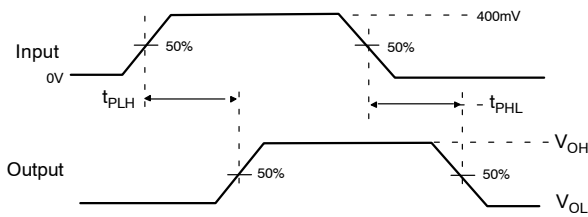

Figure 9. Propagation Delay ( $t_R$   $t_F$  = 500 ps)

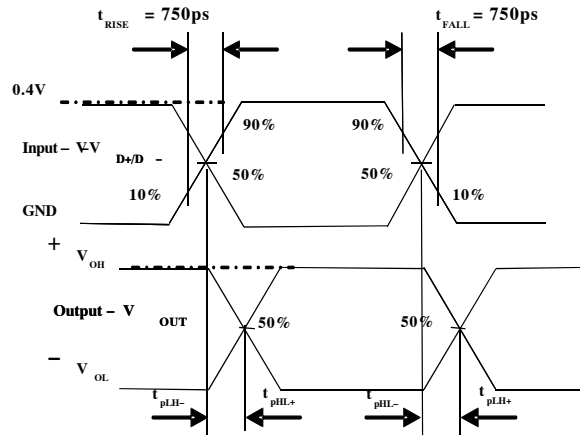
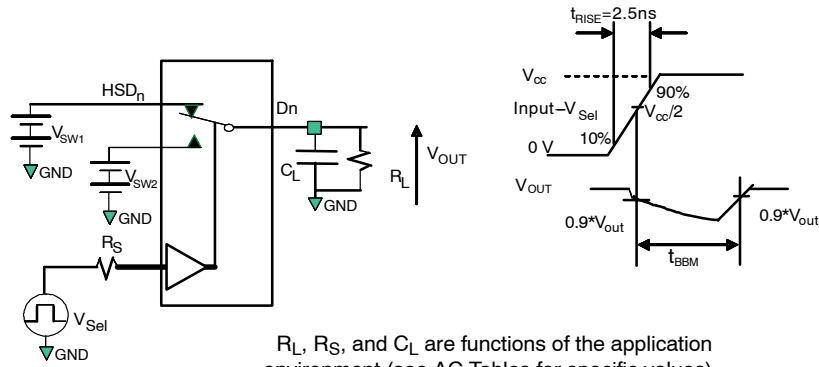

Figure 10. Skew Test Waveforms

$$t_{SK(P)} = |t_{PLH-} - t_{PHL-}| \text{ or } |t_{PLH+} - t_{PHL+}|$$

$$t_{SK(I)} = |t_{PLH-} - t_{PHL+}| \text{ or } |t_{PLH+} - t_{PHL-}|$$

TEST DIAGRAMS



$R_L$ ,  $R_S$ , and  $C_L$  are functions of the application environment (see AC Tables for specific values)  
 $C_L$  includes test fixture and stray capacitance.

Figure 11. Break-Before-Make Interval Timing

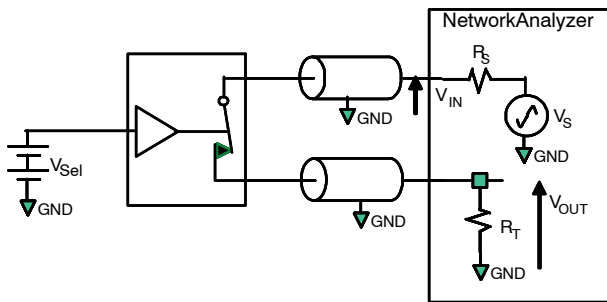

$R_S$ ,  $R_T$ , and are functions of the application environment (see AC Tables for specific values)

Figure 12. Bandwidth

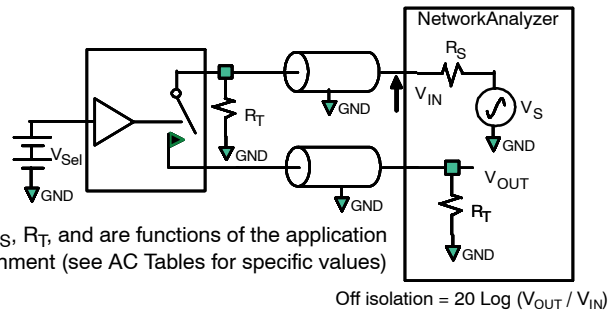

Figure 13. Channel Off Isolation

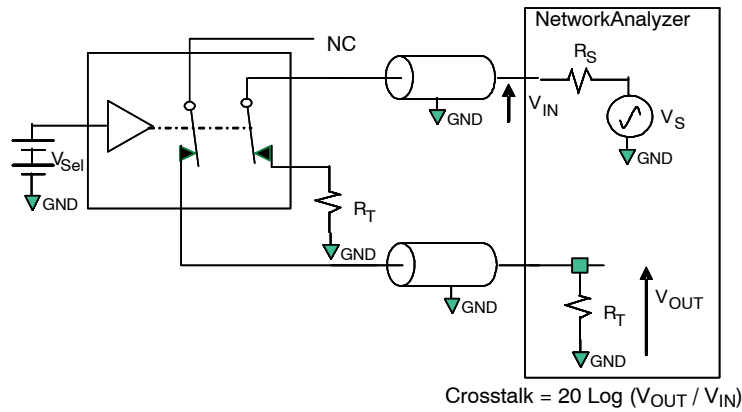

Figure 14. Non-Adjacent Channel-to-Channel Crosstalk

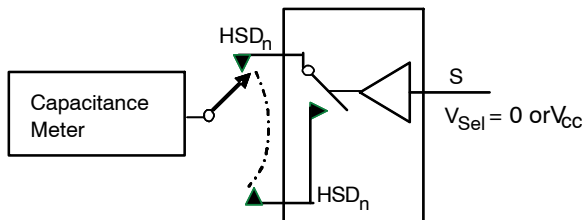

Figure 15. Channel Off Capacitance

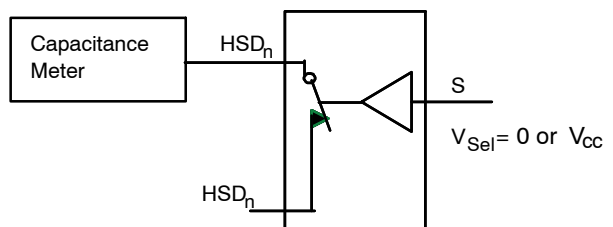
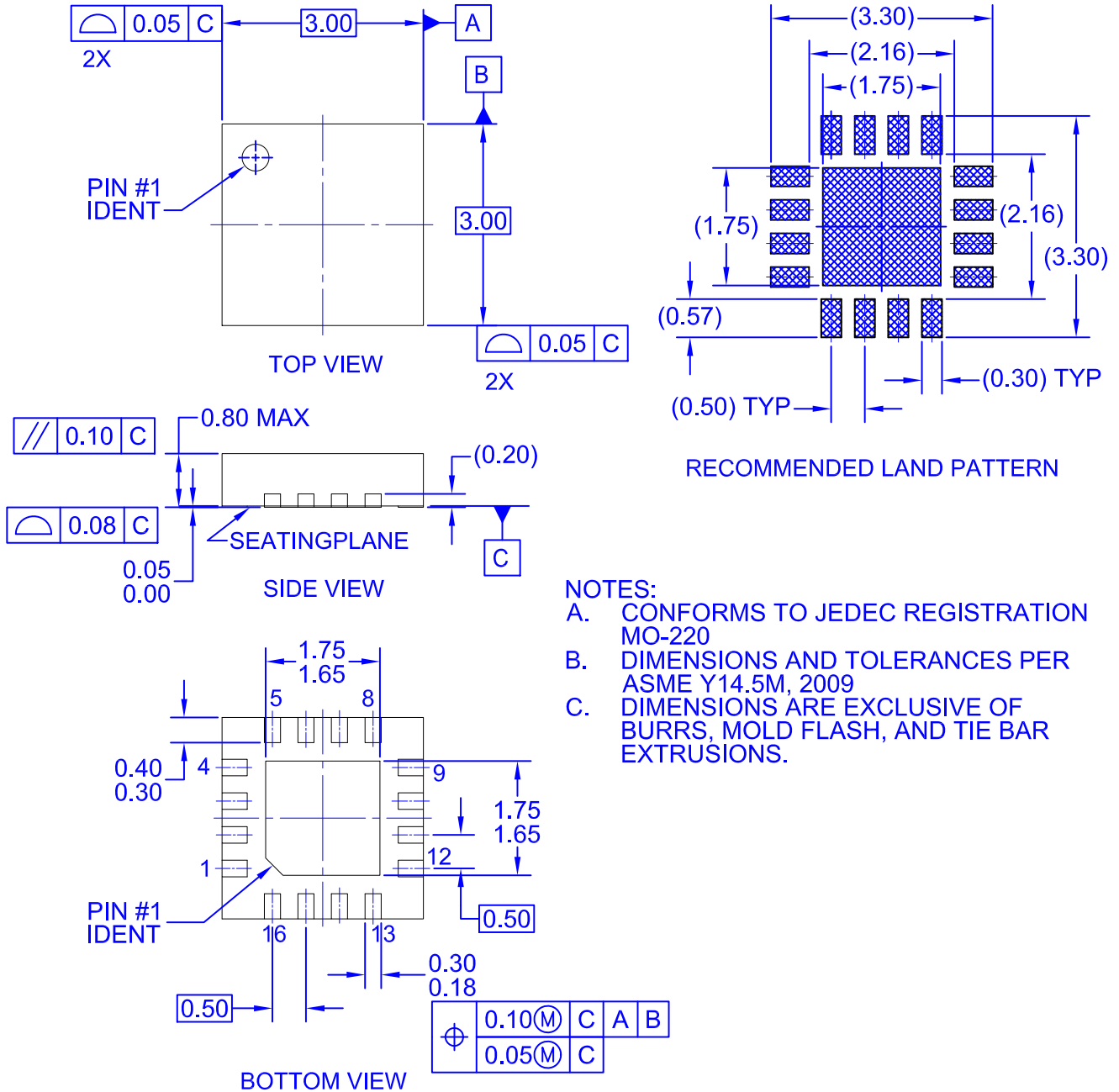

Figure 16. Channel On Capacitance

**WQFN16 3x3, 0.5P**  
CASE 510BS  
ISSUE O

DATE 31 AUG 2016



<b>DOCUMENT NUMBER:</b>	<b>98AON13630G</b>	Electronic versions are uncontrolled except when accessed directly from the Document Repository. Printed versions are uncontrolled except when stamped "CONTROLLED COPY" in red.
<b>DESCRIPTION:</b>	<b>WQFN16 3X3, 0.5P</b>	<b>PAGE 1 OF 1</b>

onsemi and ONSEMI are trademarks of Semiconductor Components Industries, LLC dba onsemi or its subsidiaries in the United States and/or other countries. onsemi reserves the right to make changes without further notice to any products herein. onsemi makes no warranty, representation or guarantee regarding the suitability of its products for any particular purpose, nor does onsemi assume any liability arising out of the application or use of any product or circuit, and specifically disclaims any and all liability, including without limitation special, consequential or incidental damages. onsemi does not convey any license under its patent rights nor the rights of others.

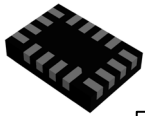

**UQFN-16 1.80x2.60x0.50, 0.40P**  
CASE 523BF  
ISSUE B

DATE 18 JUN 2026

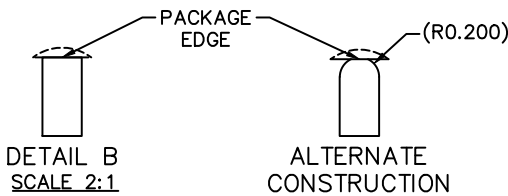
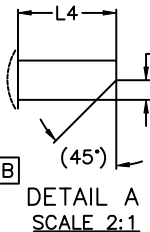
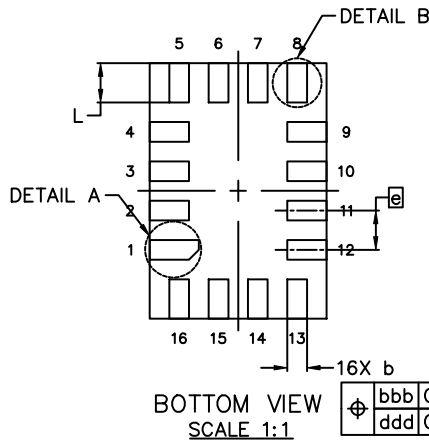
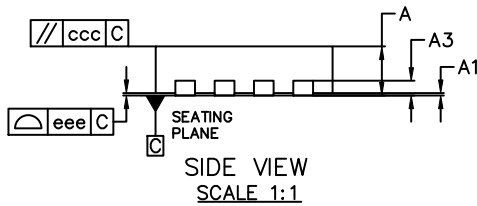
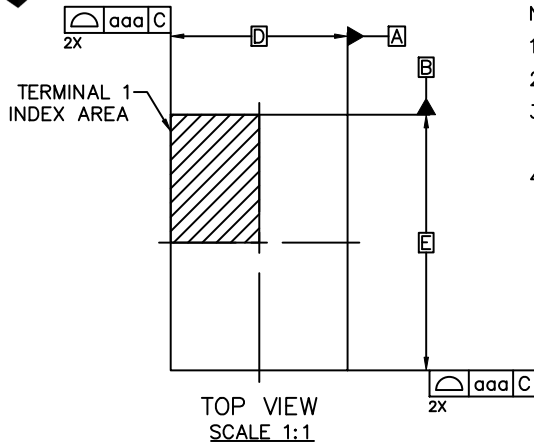

DIM	MILLIMETERS		
	MIN.	NOM.	MAX.
A	0.450	0.500	0.550
A1	0.000	0.025	0.050
A3	0.100	0.150	0.200
b	0.150	0.200	0.250
D	1.800 BSC		
E	2.600 BSC		
e	0.400 BSC		
L	0.350	0.400	0.450
L4	0.450	0.500	0.550
TOLERANCES FOR FEATURE CONTROL FRAME			
aaa	0.050		
bbb	0.100		
ccc	0.100		
ddd	0.050		
eee	0.050		

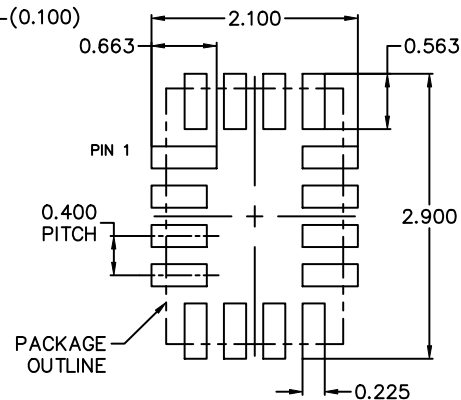

\*FOR ADDITIONAL INFORMATION ON OUR Pb-FREE STRATEGY AND SOLDERING DETAILS, PLEASE DOWNLOAD THE ONSEMI SOLDERING AND MOUNTING TECHNIQUES REFERENCE MANUAL, SOLDERRM/D.

<b>DOCUMENT NUMBER:</b>	<b>98AON13709G</b>	Electronic versions are uncontrolled except when accessed directly from the Document Repository. Printed versions are uncontrolled except when stamped "CONTROLLED COPY" in red.
<b>DESCRIPTION:</b>	<b>UQFN-16 1.80x2.60x0.50, 0.40P</b>	<b>PAGE 1 OF 1</b>

onsemi and ONSEMI are trademarks of Semiconductor Components Industries, LLC dba onsemi or its subsidiaries in the United States and/or other countries. onsemi reserves the right to make changes without further notice to any products herein. onsemi makes no warranty, representation or guarantee regarding the suitability of its products for any particular purpose, nor does onsemi assume any liability arising out of the application or use of any product or circuit, and specifically disclaims any and all liability, including without limitation special, consequential or incidental damages. onsemi does not convey any license under its patent rights nor the rights of others.

**onsemi**, **Onsemi**, and other names, marks, and brands are registered and/or common law trademarks of Semiconductor Components Industries, LLC dba "**onsemi**" or its affiliates and/or subsidiaries in the United States and/or other countries. **onsemi** owns the rights to a number of patents, trademarks, copyrights, trade secrets, and other intellectual property. A listing of **onsemi**'s product/patent coverage may be accessed at [www.onsemi.com/site/pdf/Patent-Marking.pdf](http://www.onsemi.com/site/pdf/Patent-Marking.pdf). **onsemi** reserves the right to make changes at any time to any products or information herein, without notice. The information herein is provided "as-is" and **onsemi** makes no warranty, representation or guarantee regarding the accuracy of the information, product features, availability, functionality, or suitability of its products for any particular purpose, nor does **onsemi** assume any liability arising out of the application or use of any product or circuit, and specifically disclaims any and all liability, including without limitation special, consequential or incidental damages. Buyer is responsible for its products and applications using **onsemi** products, including compliance with all laws, regulations and safety requirements or standards, regardless of any support or applications information provided by **onsemi**. "Typical" parameters which may be provided in **onsemi** data sheets and/or specifications can and do vary in different applications and actual performance may vary over time. All operating parameters, including "Typicals" must be validated for each customer application by customer's technical experts. **onsemi** does not convey any license under any of its intellectual property rights nor the rights of others. **onsemi** products are not designed, intended, or authorized for use as a critical component in life support systems or any FDA Class 3 medical devices or medical devices with a same or similar classification in a foreign jurisdiction or any devices intended for implantation in the human body. Should Buyer purchase or use **onsemi** products for any such unintended or unauthorized application, Buyer shall indemnify and hold **onsemi** and its officers, employees, subsidiaries, affiliates, and distributors harmless against all claims, costs, damages, and expenses, and reasonable attorney fees arising out of, directly or indirectly, any claim of personal injury or death associated with such unintended or unauthorized use, even if such claim alleges that **onsemi** was negligent regarding the design or manufacture of the part. **onsemi** is an Equal Opportunity/Affirmative Action Employer. This literature is subject to all applicable copyright laws and is not for resale in any manner.

## ADDITIONAL INFORMATION

### TECHNICAL PUBLICATIONS:

Technical Library: [www.onsemi.com/design/resources/technical-documentation](http://www.onsemi.com/design/resources/technical-documentation)  
onsemi Website: [www.onsemi.com](http://www.onsemi.com)

### ONLINE SUPPORT: [www.onsemi.com/support](http://www.onsemi.com/support)

For additional information, please contact your local Sales Representative at [www.onsemi.com/support/sales](http://www.onsemi.com/support/sales)