



Is Now Part of



ON Semiconductor®

To learn more about ON Semiconductor, please visit our website at
www.onsemi.com

Please note: As part of the Fairchild Semiconductor integration, some of the Fairchild orderable part numbers will need to change in order to meet ON Semiconductor's system requirements. Since the ON Semiconductor product management systems do not have the ability to manage part nomenclature that utilizes an underscore (_), the underscore (_) in the Fairchild part numbers will be changed to a dash (-). This document may contain device numbers with an underscore (_). Please check the ON Semiconductor website to verify the updated device numbers. The most current and up-to-date ordering information can be found at www.onsemi.com. Please email any questions regarding the system integration to Fairchild_questions@onsemi.com.

ON Semiconductor and the ON Semiconductor logo are trademarks of Semiconductor Components Industries, LLC dba ON Semiconductor or its subsidiaries in the United States and/or other countries. ON Semiconductor owns the rights to a number of patents, trademarks, copyrights, trade secrets, and other intellectual property. A listing of ON Semiconductor's product/patent coverage may be accessed at www.onsemi.com/site/pdf/Patent-Marking.pdf. ON Semiconductor reserves the right to make changes without further notice to any products herein. ON Semiconductor makes no warranty, representation or guarantee regarding the suitability of its products for any particular purpose, nor does ON Semiconductor assume any liability arising out of the application or use of any product or circuit, and specifically disclaims any and all liability, including without limitation special, consequential or incidental damages. Buyer is responsible for its products and applications using ON Semiconductor products, including compliance with all laws, regulations and safety requirements or standards, regardless of any support or applications information provided by ON Semiconductor. "Typical" parameters which may be provided in ON Semiconductor data sheets and/or specifications can and do vary in different applications and actual performance may vary over time. All operating parameters, including "Typicals" must be validated for each customer application by customer's technical experts. ON Semiconductor does not convey any license under its patent rights nor the rights of others. ON Semiconductor products are not designed, intended, or authorized for use as a critical component in life support systems or any FDA Class 3 medical devices or medical devices with a same or similar classification in a foreign jurisdiction or any devices intended for implantation in the human body. Should Buyer purchase or use ON Semiconductor products for any such unintended or unauthorized application, Buyer shall indemnify and hold ON Semiconductor and its officers, employees, subsidiaries, affiliates, and distributors harmless against all claims, costs, damages, and expenses, and reasonable attorney fees arising out of, directly or indirectly, any claim of personal injury or death associated with such unintended or unauthorized use, even if such claim alleges that ON Semiconductor was negligent regarding the design or manufacture of the part. ON Semiconductor is an Equal Opportunity/Affirmative Action Employer. This literature is subject to all applicable copyright laws and is not for resale in any manner.



FNB51060T1

Motion SPM[®] 55 系列

特性

- 通过 UL 第 E209204 号认证 (UL1557)
- 600 V - 10 A 三相 IGBT 逆变器 (包含提供栅极驱动和保护的控制 IC)
- 低损耗、短路额定的 IGBT
- 低端 IGBT 的独立发射极开路引脚用于三相电流感测
- 高电平有效接口, 可用于 3.3 / 5 V 逻辑电平, 施密特触发脉冲输入
- HVIC 用于实现栅极驱动、欠压及短路电流保护
- 故障输出, 用于实现欠压和短路电流保护
- 互锁功能, 防止短路
- 关断输入
- HVIC 内嵌温度感测功能, 用于监控温度
- 针对 5 kHz 开关频率进行优化
- 绝缘等级: 1500 V_{rms} / 分钟

应用

- 运动控制 — 家用设备 / 工业电机

相关资料

概述

FNB51060T1 是一款 Motion SPM 55 模块, 为交流感应、BLDC 和 PMSM 电机提供功能齐全的高性能逆变输出电路。这些模块集成了内置 IGBT 经过优化的栅极驱动, 能够最小化 EMI 和损耗, 同时提供多种模块上保护功能, 包括欠压闭锁、互锁功能、过流关断、驱动 IC 的热监控和故障报告。内置的高速 HVIC 只需要一个单电源电压, 将逻辑电平栅极输入转化为适合驱动模块强健的短路额定的 IGBT 的高电压, 高电流驱动信号。独立的 IGBT 负端在每个相位均有效, 可支持大量不同种类的控制算法。



图 1. 3D 封装图
(点击激活 3D 内容)

封装标识与订购信息

| 器件 | 器件标识 | 封装 | 包装类型 | 数量 |
|------------|------------|-----------|------|----|
| FNB51060T1 | FNB51060T1 | SPMFA-B20 | Rail | 13 |

集成的功率功能

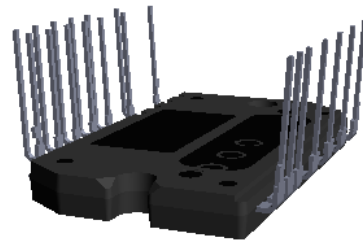
- 600 V - 10 A IGBT 逆变器，适用于三相 DC / AC 功率转换（请参阅图 3）

集成的驱动、保护和系统控制功能

- 对于逆变器高端 IGBT：栅极驱动电路、高压隔离的高速电平转换
控制电路欠压锁定保护 (UVLO)
- 对于逆变器低端 IGBT：栅极驱动电路、短路保护 (SCP)
控制电源电路欠压锁定保护 (UVLO)
- 故障信号：对应 UVLO（低端电源）和短路故障
- 输入接口：高电平有效接口，可用于 3.3 / 5 V 逻辑电平，施密特触发脉冲输入

引脚布局



图 2. 俯视图

引脚描述

| 引脚号 | 引脚名 | 引脚描述 |
|-----|----------------------|-------------------------|
| 1 | P | 直流输入正端 |
| 2 | U, V _{S(U)} | U 相输出 |
| 3 | V, V _{S(V)} | V 相输出 |
| 4 | W, V _{S(W)} | W 相输出 |
| 5 | N _U | U 相的直流输入负端 |
| 6 | N _V | V 相的直流输入负端 |
| 7 | N _W | W 相的直流输入负端 |
| 8 | IN _(UL) | 低端 U 相的信号输入 |
| 9 | IN _(UH) | 高端 U 相的信号输入 |
| 10 | IN _(VL) | 低端 V 相的信号输入 |
| 11 | IN _(VH) | 高端 V 相的信号输入 |
| 12 | IN _(WL) | 低端 W 相的信号输入 |
| 13 | IN _(WH) | 高端 W 相的信号输入 |
| 14 | V _{DD} | IC 和 IGBT 驱动的公共偏压 |
| 15 | COM | 公共电源接地 |
| 16 | C _{SC} | 短路电流感测输入电容 (低通滤波器) |
| 17 | V _F | 故障输出, 关闭输入, 驱动 IC 的温度输出 |
| 18 | V _{B(W)} | W 相 IGBT 驱动的高端偏压 |
| 19 | V _{B(V)} | V 相 IGBT 驱动的高端偏压 |
| 20 | V _{B(U)} | U 相 IGBT 驱动的高端偏压 |

内部等效电路与输入 / 输出引脚

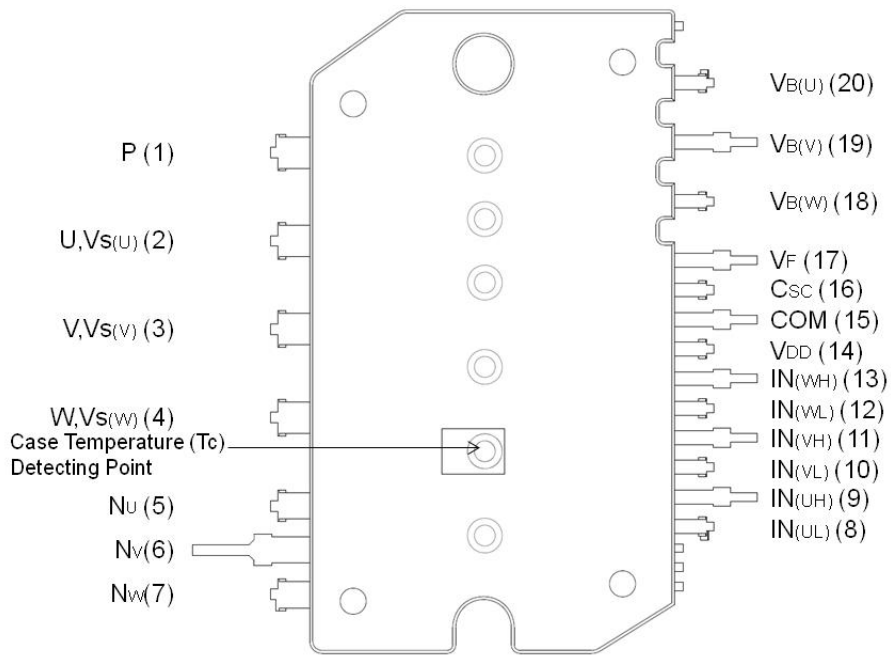

图 3. 内部框图

注:

1. 逆变器高端由三个 IGBT 组成，每个 IGBT 包括续流二极管和一个控制 IC。
2. 逆变器低端由三个 IGBT 组成，每个 IGBT 包括续流二极管和一个控制 IC。具有栅极驱动和保护功能。
3. 包含 6 个 IGBT 的栅极驱动和保护功能的单驱动 IC。
4. 逆变器的功率端由逆变器的四个直流母线输入端和三个输出端组成。

绝对最大额定值 ($T_J = 25^\circ\text{C}$, 除非另有说明。)**逆变器部分**

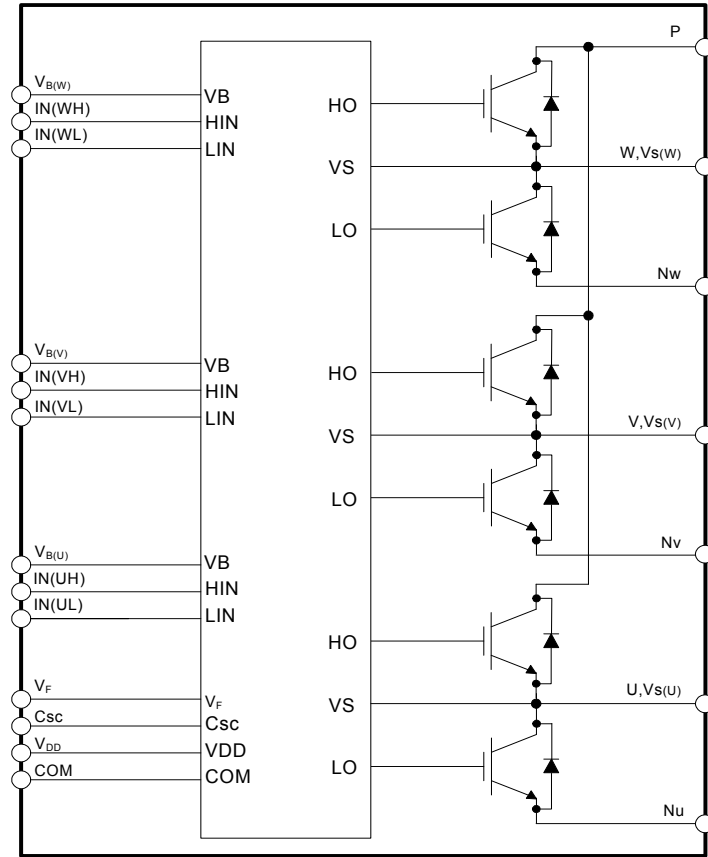
| 符号 | 参数 | 工作条件 | 额定值 | 单位 |
|---------------|---------------------|--|-----------|------------------|
| V_{PN} | 电源电压 | 施加在 P - N_U , N_V , N_W 之间 | 450 | V |
| V_{PN} (浪涌) | 电源电压 (浪涌) | 施加在 P - N_U , N_V , N_W 之间 | 500 | V |
| V_{CES} | 集电极 — 发射极之间电压 | | 600 | V |
| $\pm I_C$ | 单个 IGBT 的集电极电流 | $T_C = 25^\circ\text{C}$, $T_J < 150^\circ\text{C}$ | 10 | A |
| $\pm I_{CP}$ | 单个 IGBT 的集电极电流 (峰值) | $T_C = 25^\circ\text{C}$, $T_J < 150^\circ\text{C}$, 脉冲宽度小于 1 ms | 20 | A |
| P_C | 集电极功耗 | $T_C = 25^\circ\text{C}$, 单个芯片 | 21 | W |
| T_J | 工作结温 | (注 5) | -40 ~ 150 | $^\circ\text{C}$ |

注:

5. Motion SPM® 55 产品中集成的功率芯片的最大结温额定值为 150°C 。**控制部分**

| 符号 | 参数 | 工作条件 | 额定值 | 单位 |
|----------|----------|--|--------------------------|----|
| V_{DD} | 控制电源电压 | 施加在 V_{DD} - COM 之间 | 20 | V |
| V_{BS} | 高端控制偏压 | 施加在 $V_{B(U)} - V_{S(U)}$, $V_{B(V)} - V_{S(V)}$, $V_{B(W)} - V_{S(W)}$ | 20 | V |
| V_{IN} | 输入信号电压 | 施加在 $IN_{(UH)}$, $IN_{(VH)}$, $IN_{(WH)}$, $IN_{(UL)}$, $IN_{(VL)}$, $IN_{(WL)}$ - COM 之间 | $-0.3 \sim V_{DD} + 0.3$ | V |
| V_F | 故障电源电压 | 施加在 V_F - COM 之间 | $-0.3 \sim V_{DD} + 0.3$ | V |
| I_F | 故障电流 | V_F 引脚处的灌电流 | 5 | mA |
| V_{SC} | 电流感测输入电压 | 施加在 C_{SC} - COM 之间 | $-0.3 \sim V_{DD} + 0.3$ | V |

整个系统

| 符号 | 参数 | 工作条件 | 额定值 | 单位 |
|----------------|---------------------|---|-----------|------------------|
| $V_{PN(prot)}$ | 自我保护限制电源电压 (短路保护能力) | $V_{DD} = V_{BS} = 13.5 \sim 16.5 \text{ V}$ $T_J = 150^\circ\text{C}$, 非重复性, $< 2 \mu\text{s}$ | 400 | V |
| T_{STG} | 存储温度 | | -40 ~ 125 | $^\circ\text{C}$ |
| V_{ISO} | 绝缘电压 连接陶瓷基板到引脚 | 60 Hz, 正弦波形, 交流 1 分钟, | 1500 | V_{rms} |

热阻

| 符号 | 参数 | 工作条件 | 最小值 | 典型值 | 最大值 | 单位 |
|----------------|------------|------------------------|-----|-----|-----|-----------------------------|
| $R_{th(j-c)Q}$ | 结点 — 壳体的热阻 | 逆变器 IGBT 部分 (每 1/6 模块) | - | - | 5.9 | $^\circ\text{C} / \text{W}$ |
| $R_{th(j-c)F}$ | | 逆变器 FWD 部分 (每 1/6 模块) | - | - | 7.6 | $^\circ\text{C} / \text{W}$ |

注:

6. 关于壳体温度 (T_C) 的测量点, 参见图 2。

电气特性 ($T_J = 25^\circ\text{C}$, 除非另有说明。)

逆变器部分

| 符号 | 参数 | 工作条件 | 最小值 | 典型值 | 最大值 | 单位 | |
|---------------|----------------|---|---------------------------|-----|-----|------|----|
| $V_{CE(SAT)}$ | 集电极 - 发射极间饱和电压 | $V_{DD} = V_{BS} = 15\text{ V}$ $V_{IN} = 5\text{ V}$ $I_C = 8\text{ A}$ | $T_J = 25^\circ\text{C}$ | - | 1.8 | 2.15 | V |
| | | | $T_J = 150^\circ\text{C}$ | | 2.2 | | V |
| V_F | FWD 正向电压 | $V_{IN} = 0\text{ V}$ $I_F = 8\text{ A}$ | $T_J = 25^\circ\text{C}$ | - | 2.0 | 2.4 | V |
| | | | $T_J = 150^\circ\text{C}$ | | 1.8 | | V |
| HS | 开关时间 | $V_{PN} = 400\text{ V}$, $V_{DD} = V_{BS} = 15\text{ V}$, $I_C = 10\text{ A}$ $T_J = 25^\circ\text{C}$ $V_{IN} = 0\text{ V} \leftrightarrow 5\text{ V}$, 电感负载 (注 7) | t_{ON} | - | 700 | - | ns |
| | | | $t_{C(ON)}$ | - | 160 | - | ns |
| | | | t_{OFF} | - | 700 | - | ns |
| | | | $t_{C(OFF)}$ | - | 55 | - | ns |
| | | | t_{rr} | - | 50 | - | ns |
| LS | 开关时间 | $V_{PN} = 400\text{ V}$, $V_{DD} = V_{BS} = 15\text{ V}$, $I_C = 10\text{ A}$ $T_J = 25^\circ\text{C}$ $V_{IN} = 0\text{ V} \leftrightarrow 5\text{ V}$, 电感负载 (注 7) | t_{ON} | - | 700 | - | ns |
| | | | $t_{C(ON)}$ | - | 200 | - | ns |
| | | | t_{OFF} | - | 750 | - | ns |
| | | | $t_{C(OFF)}$ | - | 60 | - | ns |
| | | | t_{rr} | - | 40 | - | ns |
| I_{CES} | 集电极 — 发射极间漏电流 | $V_{CE} = V_{CES}$ | - | - | 1 | mA | |

注:

7. t_{ON} 和 t_{OFF} 包括模块内部驱动 IC 的传输延迟时间。 $t_{C(ON)}$ 和 $t_{C(OFF)}$ 指在内部给定的栅极驱动条件下, IGBT 本身的开关时间。详细信息, 请参见图 4。



图 4. 开关时间的定义

控制部分

| 符号 | 参数 | 工作条件 | 最小值 | 典型值 | 最大值 | 单位 | |
|---------------|-----------------|---|---|------|------|---------------|---------------|
| I_{QDD} | V_{DD} 静态电源电流 | $V_{DD} = 15\text{ V}$, $I_{N(UH, VH, WH, UL, VL, WL)} = 0\text{ V}$ | $V_{DD} - \text{COM}$ | - | 2.3 | 3.4 | mA |
| I_{PDD} | V_{DD} 工作电源电流 | $V_{DD} = 15\text{ V}$, $f_{PWM} = 20\text{ kHz}$, 占空比 = 50%, 施加一个 PWM 信号输入 | $V_{DD} - \text{COM}$ | - | 2.6 | 4.0 | mA |
| I_{QBS} | V_{BS} 静态电源电流 | $V_{BS} = 15\text{ V}$, $I_{N(UH, VH, WH)} = 0\text{ V}$ | $V_{B(U)} - V_{S(U)}$, $V_{B(V)} - V_{S(V)}$, $V_{B(W)} - V_{S(W)}$ | - | 60 | 100 | μA |
| I_{PBS} | V_{BS} 工作电源电流 | $V_{DD} = V_{BS} = 15\text{ V}$, $f_{PWM} = 20\text{ kHz}$, 占空比 = 50%, 施加于高端的一个 PWM 信号输入 | $V_{B(U)} - V_{S(U)}$, $V_{B(V)} - V_{S(V)}$, $V_{B(W)} - V_{S(W)}$ | - | 380 | 500 | μA |
| V_{FH} | 故障输出电压 | $V_{SC} = 0\text{ V}$, V_F 电路: 4.7 k Ω 至 5 V 上拉 | 4.5 | - | - | V | |
| V_{FL} | | $V_{SC} = 1\text{ V}$, V_F 电路: 4.7 k Ω 至 5 V 上拉 | - | - | 0.5 | V | |
| $V_{SC(ref)}$ | 短路触发电平 | $V_{DD} = 15\text{ V}$ (注 4) | 0.45 | 0.5 | 0.55 | V | |
| UV_{DDD} | 电源电路欠压保护 | 检测电平 | 10.0 | 11.5 | 13.0 | V | |
| UV_{DDR} | | 复位电平 | 10.5 | 12.0 | 13.5 | V | |
| UV_{BSD} | | 检测电平 | 9.5 | 11.0 | 12.5 | V | |
| UV_{BSR} | | 复位电平 | 10.0 | 11.5 | 13.0 | V | |
| I_{FT} | HVIC 温度感测电流 | $V_{DD} = V_{BS} = 15\text{ V}$, $T_{HVIC} = 25^\circ\text{C}$ | 70 | 95 | 120 | μA | |
| V_{FT} | HVIC 温度感应电压 | $V_{DD} = V_{BS} = 15\text{ V}$, $T_{HVIC} = 25^\circ\text{C}$, 4.7 k Ω 至 5 V 上拉 (图 5) | - | 4.55 | | V | |
| t_{FOD} | 故障输出脉宽 | | 40 | 100 | - | μs | |
| V_{FSDL} | 关断输入低值 | 施加在 $V_F - \text{COM}$ 之间 | - | - | 2.4 | V | |
| V_{FSDH} | 关断输入高值 | | 0.8 | - | - | V | |
| $V_{IN(ON)}$ | 导通阈值电压 | 施加在 $I_{N(UH)}$, $I_{N(VH)}$, $I_{N(WH)}$, $I_{N(UL)}$, $I_{N(VL)}$, $I_{N(WL)} - \text{COM}$ 之间 | - | - | 2.4 | V | |
| $V_{IN(OFF)}$ | 关断阈值电压 | | 0.8 | - | - | V | |

注:

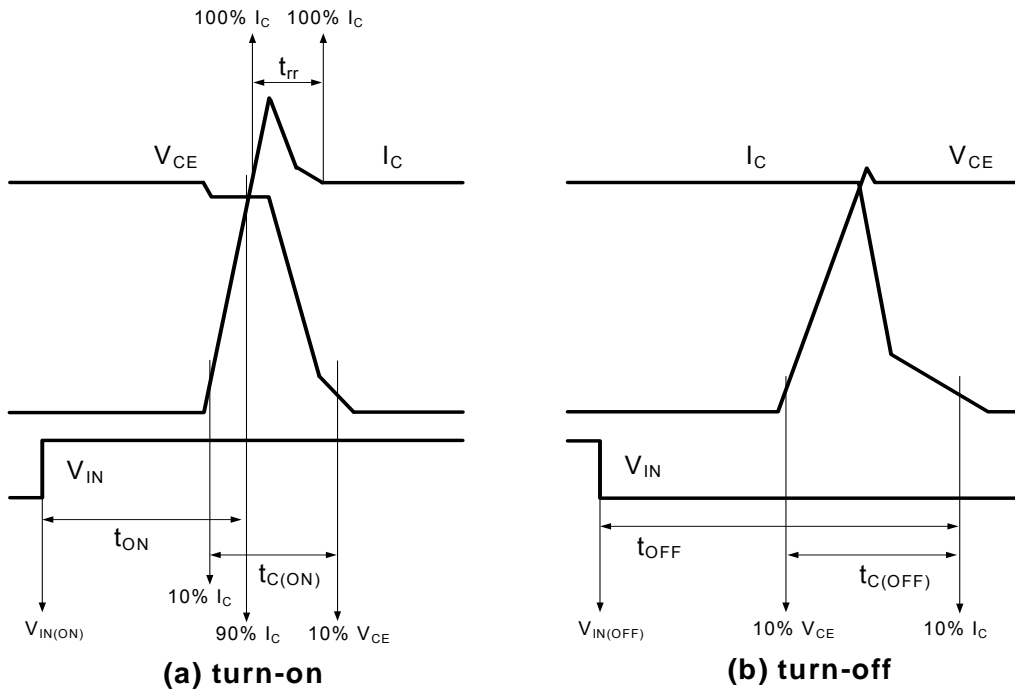
8. 短路保护作用于全部 6 个 IGBT。



图 .5.IC 温度输出曲线 V-T (采用 4.7 kohm 电阻上拉至 5 V)

推荐工作条件

| 符号 | 参数 | 工作条件 | 最小值 | 典型值 | 最大值 | 单位 |
|--------------------------------|-------------|---|------|-----|------|-------------|
| V_{PN} | 电源电压 | 施加在 P - N_U , N_V , N_W 之间 | - | 300 | 400 | V |
| V_{DD} | 控制电源电压 | 施加于 V_{DD} - COM 之间 | 14.0 | 15 | 16.5 | V |
| V_{BS} | 高端偏压 | 施加在 $V_{B(U)} - V_{S(U)}$, $V_{B(V)} - V_{S(V)}$, $V_{B(W)} - V_{S(W)}$ | 13.0 | 15 | 18.5 | V |
| dV_{DD}/dt , dV_{BS}/dt | 控制电源波动 | | -1 | - | 1 | V / μ s |
| t_{dead} | 防止桥臂直通的死区时间 | 适用于每个输入信号 | 0.5 | - | - | μ s |
| f_{PWM} | PWM 输入信号 | $-40^\circ\text{C} < T_J < 150^\circ\text{C}$ | - | - | 20 | kHz |
| V_{SEN} | 电流感测的电压 | 施加在 N_U , N_V , N_W - COM 之间 (包括浪涌电压) | -4 | | 4 | V |
| $P_{WIN(ON)}$ | 最小输入脉宽 | (注 9) | 0.7 | - | - | μ s |
| $P_{WIN(OFF)}$ | | | 0.7 | - | - | |

注:

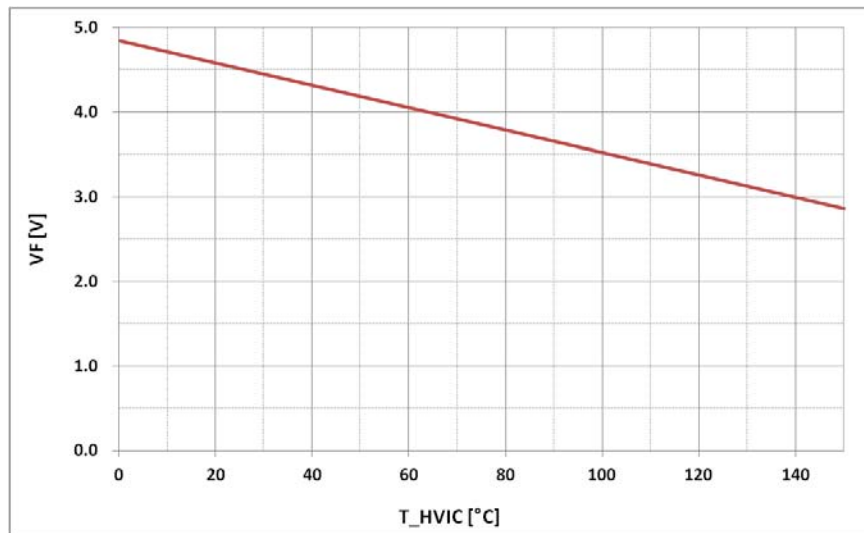
9. 此产品可能不会响应, 若输入脉宽值低于最低推荐值。

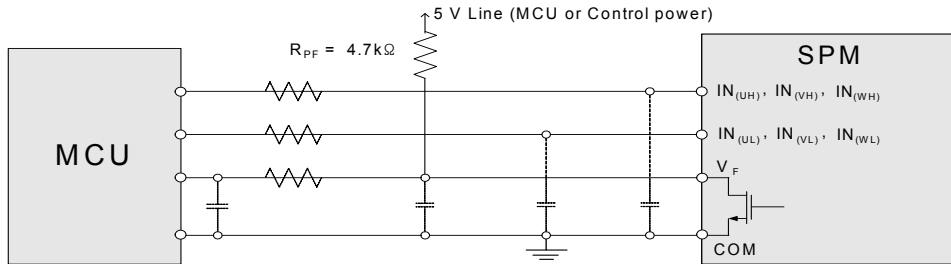

注:

10. 每个输入端的 RC 耦合 (虚线显示部分) 可能随着应用程序中使用的 PWM 控制方案和应用程序印刷电路板接线抗阻而改变。Motion SPM 55 产品的输入信号部分集成了 5 k Ω (典型值) 下拉电阻。因此, 当使用外部的滤波电阻时, 请注意该信号在输入端的压降。

图 6. 推荐的 MCU I/O 接口电路

机械特性和额定值

| 参数 | 工作条件 | | 最小值 | 典型值 | 最大值 | 单位 |
|-------|---------------------|--------------|-----|-----|-----|-------|
| 器件平面度 | 见图 7 | | -50 | - | 100 | μm |
| 安装扭矩 | 安装螺钉: - M3 注释图 8 | 建议 0.7 N·m | 0.6 | 0.7 | 0.8 | N·m |
| | | 建议 7.1 kg·cm | 5.9 | 6.9 | 7.9 | kg·cm |
| 重量 | | | - | 6.0 | - | g |



图 7. 平面度测量位置



图 8. 安装螺钉时的扭紧顺序

注:

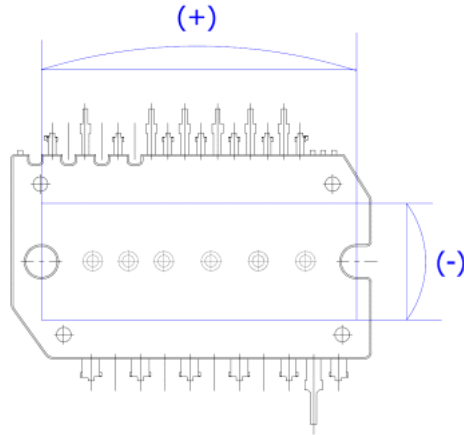
- 11. 安装或扭动螺丝时切勿过分用力。扭力过大会造成封装破裂，产生毛刺并破坏铝质散热片。
- 12. 避免用力不均衡。图 10 显示了安装螺钉时，推荐的扭紧顺序。不平坦的安装会导致 SPM 55 产品的陶瓷基板损坏。预旋紧扭矩约为最大额定扭矩的 20 ~ 30%。

保护功能时序图

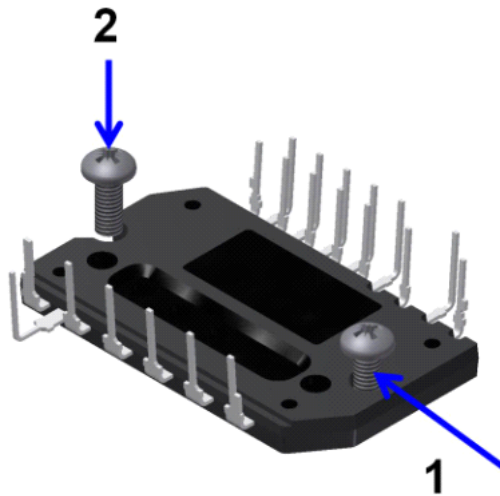
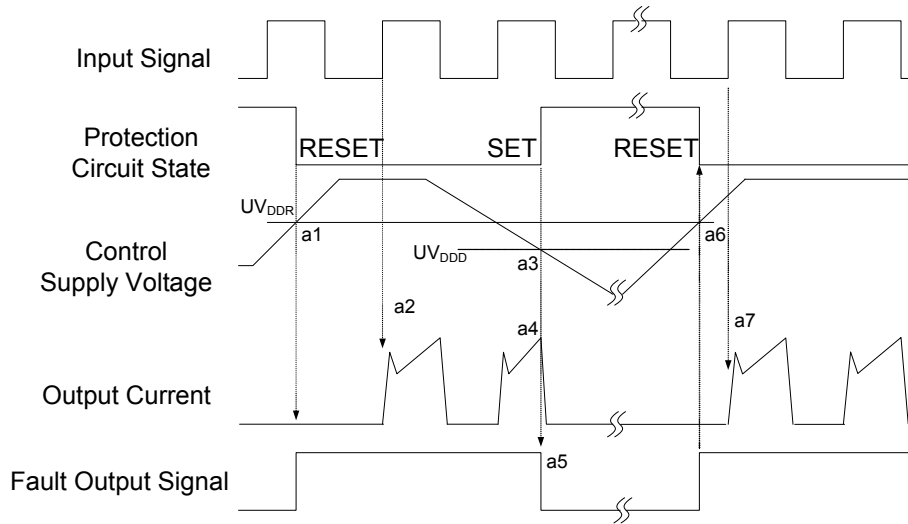

- a1: 控制电源电压上升: 当电压上升到 UV_{DDR} 后, 等到下一个开通信号时, 对应的电路才开始动作。
- a2: 正常工作: IGBT 导通并加载负载电流。
- a3: 欠压检测 (UV_{DD})。
- a4: 不论控制输入的条件, IGBT 都关断。
- a5: 故障输出工作启动。
- a6: 欠压复位 (UV_{DDR})。
- a7: 正常工作: IGBT 导通并加载负载电流。

图 9. 欠压保护 (低端)

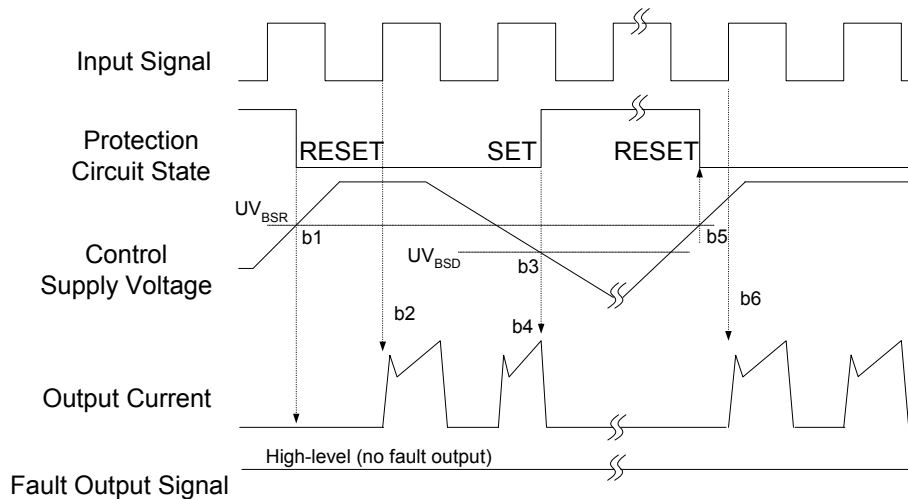

- b1: 控制电源电压上升: 当电压上升到 UV_{BSR} 后, 等到下一个输入信号时, 对应的电路才开始动作。
- b2: 正常工作: IGBT 导通并加载负载电流。
- b3: 欠压检测 (UV_{BSD})。
- b4: 不论控制输入的条件, IGBT 都关闭, 且无故障输出信号。
- b5: 欠压复位 (UV_{BSR})。
- b6: 正常工作: IGBT 导通并加载负载电流。

图 10. 欠压保护 (高端)

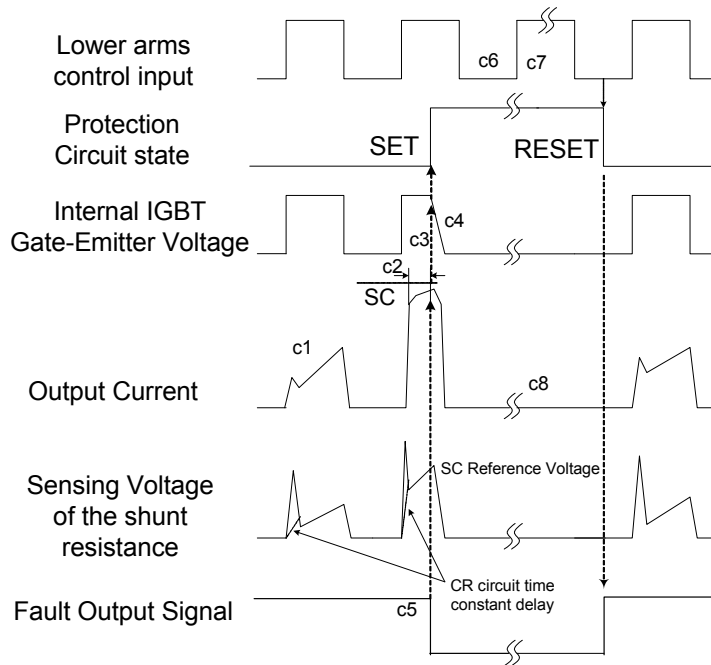

(包含外部分流电阻和 CR 连接)

- c1: 正常工作: IGBT 导通并加载负载电流。
- c2: 短路电流检测 (SC 触发)。
- c3: IGBT 栅极硬中断。
- c4: IGBT 关断。
- c5: 输入 “L”: IGBT 关断状态。
- c6: 输入 “H”: IGBT 导通状态, 但是在故障输出有效的时间内, IGBT 不导通。
- c7: IGBT 关断状态

图 11. 短路保护

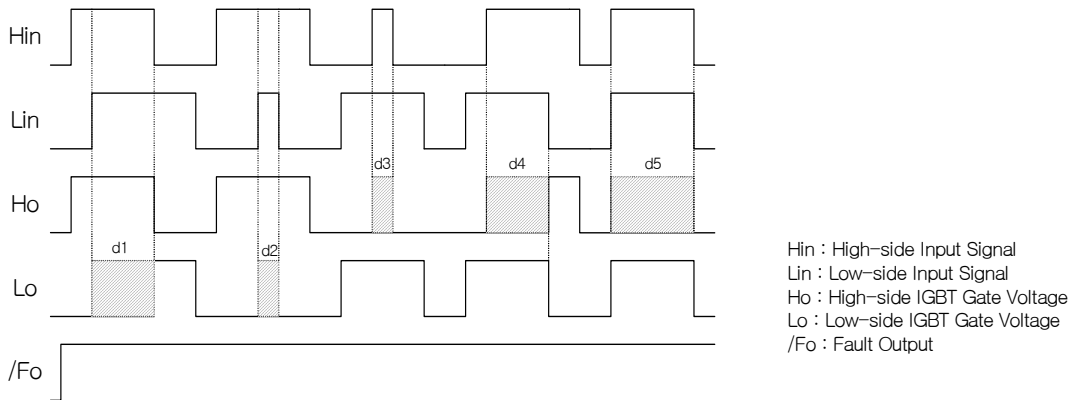

- d1: 高端先入先出模式
- d2: 低端噪声模式低端无输出
- d3: 高端噪声模式高端无输出
- d4: 低端先入先出模式
- d5: 同相模式高端无输出

图 12. 互锁功能

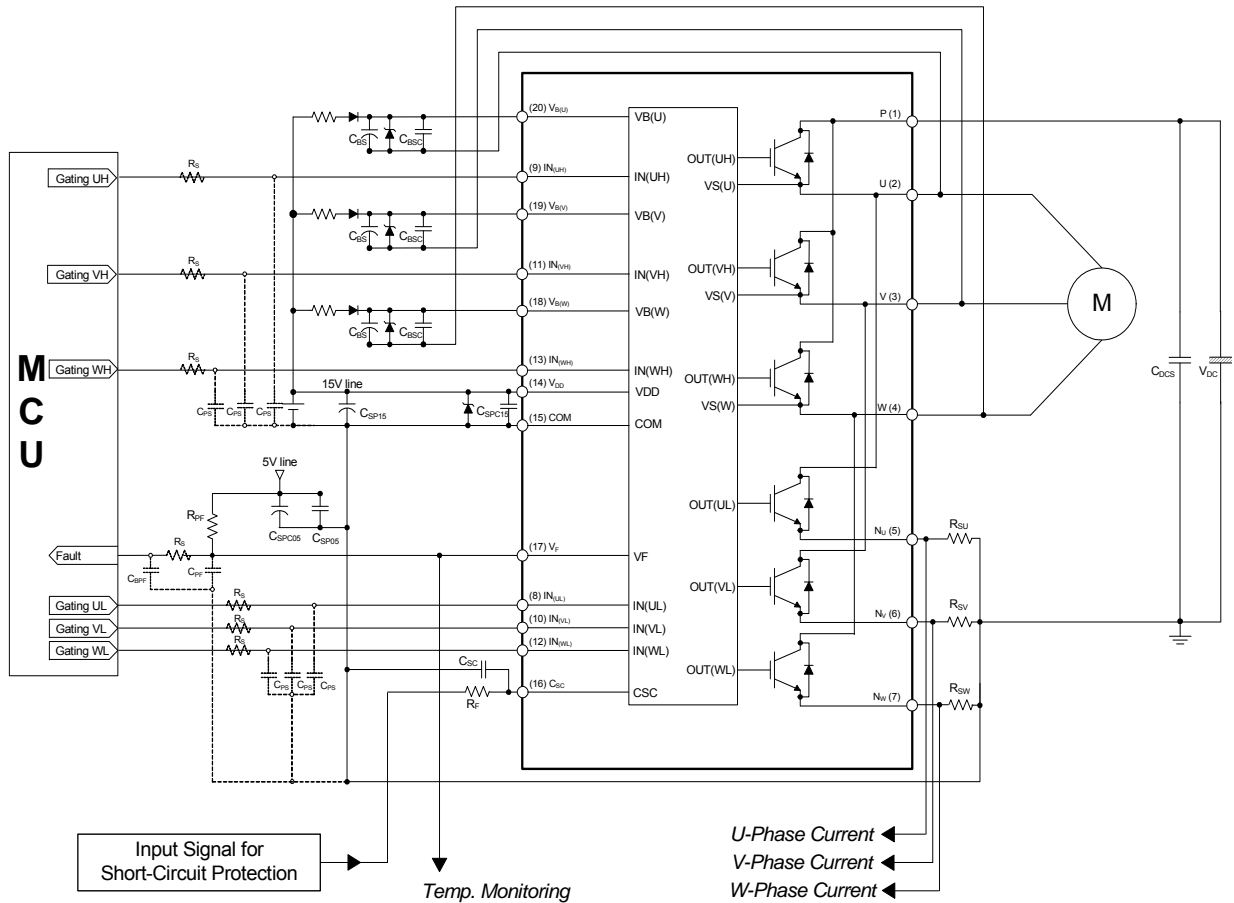

注:

- 1) 为了避免故障，应尽可能缩短每个输入端的连线。（小于 2 ~ 3 cm）
- 2) 因为 Motion SPM® 55 产品内部集成了一个具有特殊功能的 HVIC，接口电路与 MCU 端口的直接耦合是可行的，不需要任何光耦合器或变压器隔离。
- 3) V_{FO} 是漏极开路型。该信号线应当采用一个能把 I_{FO} 上升到 5 mA 的电阻上拉至 MCU 或控制电源的正极。请参阅图 14。
- 4) 推荐 C_{SP15} 的取值应大于自举电容 C_{BS} 的 7 倍左右。
- 5) 输入信号为高电平有效。在 IC 中，有一个 5 kΩ 的电阻将每一个输入信号线下拉接地。推荐采用 RC 耦合电路，以避免输入信号波动。推荐 $R_S C_{PS}$ 时间常数应该选择在 50 ~ 150 ns 范围内。（推荐 $R_S = 100 \Omega$ ， $C_{PS} = 1 \text{ nF}$ ）
- 6) 为了防止保护功能出错， R_F 和 C_{SC} 周围的连线应该尽可能的短。
- 7) 在短路保护电路中， $R_F C_{SC}$ 的时间常数应在 1.5 ~ 2 μs 的范围内选取。
- 8) 控制 GND 线和功率 GND 线包括 N_U ， N_V ， N_W 必须连接在同一点上。请不要用宽的模块连接控制 GND 线和功率 GND 线。同时，控制 GND 线和功率 GND 线之间的接线距离应该尽可能的短。
- 9) 每个电容都应尽可能地靠近 Motion SPM 55 产品的引脚安装。
- 10) 为防止浪涌的破坏，应尽可能缩短滤波电容和 P 和 GND 引脚间的连线。推荐在 P 和 GND 引脚间使用 0.1 ~ 0.22 μF 的高频无感电容。
- 11) 在各种家用电器设备系统中，几乎都用到了继电器。在这些情况下，CPU 和继电器之间应留有足够的距离。
- 12) 在每一对控制电源端应该采用齐纳二极管或者瞬态电压抑制器来保护 IC 不受浪涌破坏。（推荐 22 V / 1 W，齐纳阻抗特性低于 15 Ω 的齐纳二极管）
- 13) 请为 C_{BS} 选择温度特性好的电解电容。同时，为 C_{BSC} 选择 0.1 ~ 0.2 μF 温度和频率特性好的 R- 类陶瓷电容。
- 14) 详细信息，请参考应用说明。

图 13. 典型应用电路

封装轮廓详图 (FNB50560T1, Short Lead)

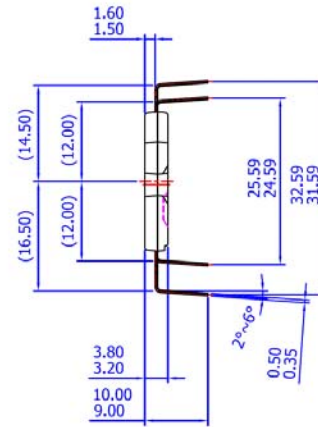
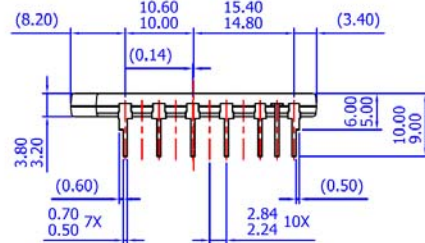
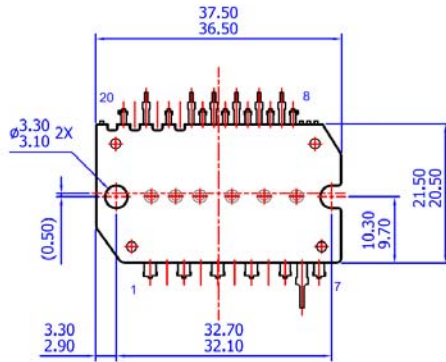
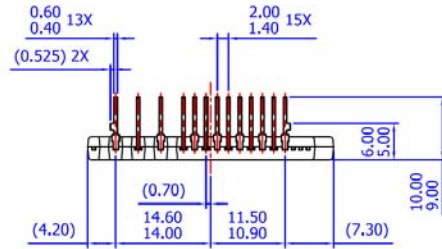

- NOTES: UNLESS OTHERWISE SPECIFIED
- A) THIS PACKAGE DOES NOT COMPLY TO ANY CURRENT PACKAGING STANDARD
 - B) ALL DIMENSIONS ARE IN MILLIMETERS
 - C) DIMENSIONS ARE EXCLUSIVE OF BURRS, MOLD FLASH, AND TIE BAR EXTRUSIONS
 - D) () IS REFERENCE
 - E) [] IS ASS'Y QUALITY
 - F) DRAWING FILENAME: MOD20DBREV2



TRADEMARKS

The following includes registered and unregistered trademarks and service marks, owned by Fairchild Semiconductor and/or its global subsidiaries, and is not intended to be an exhaustive list of all such trademarks.

- | | | | |
|--------------------------|--|---------------------------------------|------------------|
| AccuPower™ | F-PFS™ | | |
| Awinda® | FRFET® | PowerTrench® | TinyBoost® |
| AX-CAP®* | Global Power Resource™ | PowerXS™ | TinyBuck® |
| BitSiC™ | GreenBridge™ | Programmable Active Droop™ | TinyCalc™ |
| Build it Now™ | Green FPS™ | QFET® | TinyLogic® |
| CorePLUS™ | Green FPS™ e-Series™ | QS™ | TINYOPTO™ |
| CorePOWER™ | Gmax™ | Quiet Series™ | TinyPower™ |
| CROSSVOLT™ | GTO™ | RapidConfigure™ | TinyPWM™ |
| CTL™ | IntelliMAX™ | | TinyWire™ |
| Current Transfer Logic™ | ISOPLANAR™ | Saving our world, 1mW/W/kW at a time™ | TranSiC™ |
| DEUXPEED® | Making Small Speakers Sound Louder and Better™ | SignalWise™ | TriFault Detect™ |
| Dual Cool™ | MegaBuck™ | SmartMax™ | TRUECURRENT®* |
| EcoSPARK® | MICROCOUPLER™ | SMART START™ | µSerDes™ |
| EfficientMax™ | MicroFET™ | Solutions for Your Success™ | |
| ESBC™ | MicroPak™ | SPM® | UHC® |
| | MicroPak2™ | STEALTH™ | Ultra FRFET™ |
| Fairchild® | MillerDrive™ | SuperFET® | UniFET™ |
| Fairchild Semiconductor® | MotionMax™ | SuperSOT™-3 | VCX™ |
| FACT Quiet Series™ | MotionGrid® | SuperSOT™-6 | VisualMax™ |
| FACT® | MTI® | SuperSOT™-8 | VoltagePlus™ |
| FAST® | MTx® | SupreMOS® | XS™ |
| FastvCore™ | MVN® | SyncFET™ | Xsens™ |
| FETBench™ | mWSaver® | Sync-Lock™ | 仙童™ |
| FPS™ | OptoHiT™ | | |

* Trademarks of System General Corporation, used under license by Fairchild Semiconductor.

DISCLAIMER

FAIRCHILD SEMICONDUCTOR RESERVES THE RIGHT TO MAKE CHANGES WITHOUT FURTHER NOTICE TO ANY PRODUCTS HEREIN TO IMPROVE RELIABILITY, FUNCTION, OR DESIGN. TO OBTAIN THE LATEST, MOST UP-TO-DATE DATASHEET AND PRODUCT INFORMATION, VISIT OUR WEBSITE AT [HTTP://WWW.FAIRCHILDSEMI.COM](http://www.fairchildsemi.com). FAIRCHILD DOES NOT ASSUME ANY LIABILITY ARISING OUT OF THE APPLICATION OR USE OF ANY PRODUCT OR CIRCUIT DESCRIBED HEREIN; NEITHER DOES IT CONVEY ANY LICENSE UNDER ITS PATENT RIGHTS, NOR THE RIGHTS OF OTHERS. THESE SPECIFICATIONS DO NOT EXPAND THE TERMS OF FAIRCHILD'S WORLDWIDE TERMS AND CONDITIONS, SPECIFICALLY THE WARRANTY THEREIN, WHICH COVERS THESE PRODUCTS.

LIFE SUPPORT POLICY

FAIRCHILD'S PRODUCTS ARE NOT AUTHORIZED FOR USE AS CRITICAL COMPONENTS IN LIFE SUPPORT DEVICES OR SYSTEMS WITHOUT THE EXPRESS WRITTEN APPROVAL OF FAIRCHILD SEMICONDUCTOR CORPORATION.

As used herein:

- Life support devices or systems are devices or systems which, (a) are intended for surgical implant into the body or (b) support or sustain life, and (c) whose failure to perform when properly used in accordance with instructions for use provided in the labeling, can be reasonably expected to result in a significant injury of the user.
- A critical component in any component of a life support, device, or system whose failure to perform can be reasonably expected to cause the failure of the life support device or system, or to affect its safety or effectiveness.

ANTI-COUNTERFEITING POLICY

Fairchild Semiconductor Corporation's Anti-Counterfeiting Policy. Fairchild's Anti-Counterfeiting Policy is also stated on our external website, www.fairchildsemi.com, under Sales Support.

Counterfeiting of semiconductor parts is a growing problem in the industry. All manufacturers of semiconductor products are experiencing counterfeiting of their parts. Customers who inadvertently purchase counterfeit parts experience many problems such as loss of brand reputation, substandard performance, failed applications, and increased cost of production and manufacturing delays. Fairchild is taking strong measures to protect ourselves and our customers from the proliferation of counterfeit parts. Fairchild strongly encourages customers to purchase Fairchild parts either directly from Fairchild or from Authorized Fairchild Distributors who are listed by country on our web page cited above. Products customers buy either from Fairchild directly or from Authorized Fairchild Distributors are genuine parts, have full traceability, meet Fairchild's quality standards for handling and storage and provide access to Fairchild's full range of up-to-date technical and product information. Fairchild and our Authorized Distributors will stand behind all warranties and will appropriately address any warranty issues that may arise. Fairchild will not provide any warranty coverage or other assistance for parts bought from Unauthorized Sources. Fairchild is committed to combat this global problem and encourage our customers to do their part in stopping this practice by buying direct or from authorized distributors.

PRODUCT STATUS DEFINITIONS

Definition of Terms

| Datasheet Identification | Product Status | Definition |
|--------------------------|-----------------------|---|
| Advance Information | Formative / In Design | Datasheet contains the design specifications for product development. Specifications may change in any manner without notice. |
| Preliminary | First Production | Datasheet contains preliminary data; supplementary data will be published at a later date. Fairchild Semiconductor reserves the right to make changes at any time without notice to improve design. |
| No Identification Needed | Full Production | Datasheet contains final specifications. Fairchild Semiconductor reserves the right to make changes at any time without notice to improve the design. |
| Obsolete | Not In Production | Datasheet contains specifications on a product that is discontinued by Fairchild Semiconductor. The datasheet is for reference information only. |

Rev. 171

ON Semiconductor and  are trademarks of Semiconductor Components Industries, LLC dba ON Semiconductor or its subsidiaries in the United States and/or other countries. ON Semiconductor owns the rights to a number of patents, trademarks, copyrights, trade secrets, and other intellectual property. A listing of ON Semiconductor's product/patent coverage may be accessed at www.onsemi.com/site/pdf/Patent-Marking.pdf. ON Semiconductor reserves the right to make changes without further notice to any products herein. ON Semiconductor makes no warranty, representation or guarantee regarding the suitability of its products for any particular purpose, nor does ON Semiconductor assume any liability arising out of the application or use of any product or circuit, and specifically disclaims any and all liability, including without limitation special, consequential or incidental damages. Buyer is responsible for its products and applications using ON Semiconductor products, including compliance with all laws, regulations and safety requirements or standards, regardless of any support or applications information provided by ON Semiconductor. "Typical" parameters which may be provided in ON Semiconductor data sheets and/or specifications can and do vary in different applications and actual performance may vary over time. All operating parameters, including "Typicals" must be validated for each customer application by customer's technical experts. ON Semiconductor does not convey any license under its patent rights nor the rights of others. ON Semiconductor products are not designed, intended, or authorized for use as a critical component in life support systems or any FDA Class 3 medical devices or medical devices with a same or similar classification in a foreign jurisdiction or any devices intended for implantation in the human body. Should Buyer purchase or use ON Semiconductor products for any such unintended or unauthorized application, Buyer shall indemnify and hold ON Semiconductor and its officers, employees, subsidiaries, affiliates, and distributors harmless against all claims, costs, damages, and expenses, and reasonable attorney fees arising out of, directly or indirectly, any claim of personal injury or death associated with such unintended or unauthorized use, even if such claim alleges that ON Semiconductor was negligent regarding the design or manufacture of the part. ON Semiconductor is an Equal Opportunity/Affirmative Action Employer. This literature is subject to all applicable copyright laws and is not for resale in any manner.

PUBLICATION ORDERING INFORMATION

LITERATURE FULFILLMENT:

Literature Distribution Center for ON Semiconductor
19521 E. 32nd Pkwy, Aurora, Colorado 80011 USA
Phone: 303-675-2175 or 800-344-3860 Toll Free USA/Canada
Fax: 303-675-2176 or 800-344-3867 Toll Free USA/Canada
Email: orderlit@onsemi.com

N. American Technical Support: 800-282-9855 Toll Free
USA/Canada
Europe, Middle East and Africa Technical Support:
Phone: 421 33 790 2910
Japan Customer Focus Center
Phone: 81-3-5817-1050

ON Semiconductor Website: www.onsemi.com
Order Literature: <http://www.onsemi.com/orderlit>
For additional information, please contact your local
Sales Representative