

MOSFET – N-Channel, SUPERFET®

600 V, 20 A, 190 mΩ

FCA20N60

Description

SUPERFET MOSFET is onsemi’s first generation of high voltage super-junction (SJ) MOSFET family that is utilizing charge balance technology for outstanding low on-resistance and lower gate charge performance. This technology is tailored to minimize conduction loss, provide superior switching performance, dv/dt rate and higher avalanche energy. Consequently, SuperFET MOSFET is very suitable for the switching power applications such as PFC, server/telecom power, FPD TV power, ATX power and industrial power applications.

Features

- 650 V @ $T_J = 150^\circ\text{C}$
- Typ. $R_{DS(on)} = 150\text{ m}\Omega$
- Ultra Low Gate Charge (Typ. $Q_g = 75\text{ nC}$)
- Low Effective Output Capacitance (Typ. $C_{oss(eff.)} = 165\text{ pF}$)
- 100% Avalanche Tested
- This Device is Pb-Free

Applications

- Solar Inverter
- AC-DC Power Supply

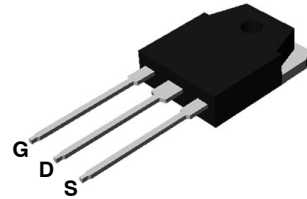

TO-3P-3L
 CASE 340BZ

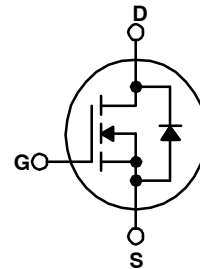

MARKING DIAGRAM

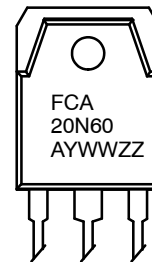

FCA20N60 = Specific Device Code
 A = Assembly Location
 YWW = Date Code (Year and Week)
 ZZ = Assembly Lot Code

ORDERING INFORMATION

Device	Package	Shipping†
FCA20N60	TO-3P-3L (Pb-Free)	450 Units / Tube
FCA20N60-F109	TO-3P-3L (Pb-Free)	450 Units / Tube

†For information on tape and reel specifications, including part orientation and tape sizes, please refer to our Tape and Reel Packaging Specifications Brochure, [BRD8011/D](#).

FCA20N60

MOSFET MAXIMUM RATINGS

($T_C = 25^\circ\text{C}$ unless otherwise noted.)

Symbol	Parameter	Value	Unit
V_{DSS}	Drain to Source Voltage	600	V
V_{GSS}	Gate-Source Voltage	± 30	V
I_D	Drain Current - Continuous ($T_C = 25^\circ\text{C}$) - Continuous ($T_C = 100^\circ\text{C}$)	20 12.5	A
I_{DM}	Drain Current - Pulsed (Note 1)	60	A
E_{AS}	Single Pulsed Avalanche Energy (Note 2)	690	mJ
I_{AR}	Avalanche Current (Note 1)	20	A
E_{AR}	Repetitive Avalanche Energy (Note 1)	20.8	mJ
dv/dt	Peak Diode Recovery dv/dt (Note 3)	4.5	V/ns
P_D	Power Dissipation - ($T_C = 25^\circ\text{C}$) - Derate Above 25°C	208 1.67	W W/ $^\circ\text{C}$
T_J, T_{STG}	Operating and Storage Temperature Range	-55 to +150	$^\circ\text{C}$
T_L	Maximum Lead Temperature for Soldering Purpose, 1/8" from Case for 5 Seconds	300	$^\circ\text{C}$

Stresses exceeding those listed in the Maximum Ratings table may damage the device. If any of these limits are exceeded, device functionality should not be assumed, damage may occur and reliability may be affected.

FCA20N60

THERMAL CHARACTERISTICS

Symbol	Parameter	Value	Unit
$R_{\theta JC}$	Thermal Resistance, Junction to Case, Max	0.6	°C/W
$R_{\theta JA}$	Thermal Resistance, Junction to Ambient, Max.	41.7	

ELECTRICAL CHARACTERISTICS (T_C = 25°C unless otherwise noted)

Symbol	Parameter	Test Conditions	Min	Typ	Max	Unit
--------	-----------	-----------------	-----	-----	-----	------

Off Characteristics

BV_{DSS}	Drain–Source Breakdown Voltage	$I_D = 250 \mu A, V_{GS} = 0 V, T_J = 25^\circ C$	600	–	–	V
		$I_D = 250 \mu A, V_{GS} = 0 V, T_J = 150^\circ C$	–	650	–	V
$\frac{\Delta BV_{DSS}}{\Delta T_J}$	Breakdown Voltage Temperature Coefficient	$I_D = 250 \mu A$, Referenced to 25°C	–	0.6	–	V/°C
BV_{DS}	Drain–Source Avalanche Breakdown Voltage	$V_{GS} = 0 V, I_D = 20 A$	–	700	–	V
I_{DSS}	Zero Gate Voltage Drain Current	$V_{DS} = 600 V, V_{GS} = 0 V$	–	–	1	μA
		$V_{DS} = 480 V, T_C = 125^\circ C$	–	–	10	
I_{GSS}	Gate to Body Leakage Current	$V_{GS} = \pm 30 V, V_{DS} = 0 V$	–	–	±100	nA

On Characteristics

$V_{GS(th)}$	Gate Threshold Voltage	$V_{GS} = V_{DS}, I_D = 250 \mu A$	3.0	–	5.0	V
$R_{DS(on)}$	Static Drain to Source On Resistance	$V_{GS} = 10 V, I_D = 10 A$	–	0.15	0.19	Ω
g_{FS}	Forward Transconductance	$V_{DS} = 40 V, I_D = 10 A$	–	17	–	S

Dynamic Characteristics

C_{iss}	Input Capacitance	$V_{DS} = 25 V, V_{GS} = 0 V, f = 1 MHz$	–	2370	3080	pF
C_{oss}	Output Capacitance		–	1280	1665	
C_{riss}	Reverse Transfer Capacitance		–	95	–	
C_{oss}	Output Capacitance	$V_{DS} = 480 V, V_{GS} = 0 V, f = 1 MHz$	–	65	85	pF
$C_{oss(eff.)}$	Effective Output Capacitance	$V_{DS} = 0 V$ to 400 V, $V_{GS} = 0 V$	–	165	–	pF
Q_g	Total Gate Charge at 10 V	$V_{DS} = 480 V, I_D = 20 A,$ $V_{GS} = 10 V$ (Note 4)	–	75	98	nC
Q_{gs}	Gate to Source Charge		–	13.5	18	
Q_{gd}	Gate to Drain “Miller” Charge		–	36	–	

Switching Characteristics

$t_{d(on)}$	Turn–On Delay Time	$V_{DD} = 300 V, I_D = 20 A,$ $V_{GS} = 10 V R_G = 25 \Omega$ (Note 4)	–	62	135	ns
t_r	Turn–On Rise Time		–	140	290	
$t_{d(off)}$	Turn–Off Delay Time		–	230	470	
t_f	Turn–Off Fall Time		–	65	140	

Drain–Source Diode Characteristics and Maximum Ratings

I_S	Maximum Continuous Drain to Source Diode Forward Current	–	–	20	A	
I_{SM}	Maximum Pulsed Drain to Source Diode Forward Current	–	–	60	A	
V_{SD}	Drain–Source Diode Forward Voltage	$V_{GS} = 0 V, I_{SD} = 20 A$	–	–	1.4	V
t_{rr}	Reverse Recovery Time	$V_{GS} = 0 V, I_{SD} = 20 A,$ $di_F/dt = 100 A/\mu s$	–	530	–	ns
Q_{rr}	Reverse Recovery Charge		–	10.5	–	μC

Product parametric performance is indicated in the Electrical Characteristics for the listed test conditions, unless otherwise noted. Product performance may not be indicated by the Electrical Characteristics if operated under different conditions.

NOTES:

1. Repetitive Rating: Pulse width–limited by maximum junction temperature.
2. $I_{AS} = 10 A, V_{DD} = 50 V, R_G = 25 \Omega$, starting $T_J = 25^\circ C$.
3. $I_{SD} \leq 20 A, di/dt \leq 200 A/\mu s, V_{DD} \leq BV_{DSS}$, starting $T_J = 25^\circ C$.
4. Essentially independent of operating temperature typical Characteristics.

TYPICAL CHARACTERISTICS

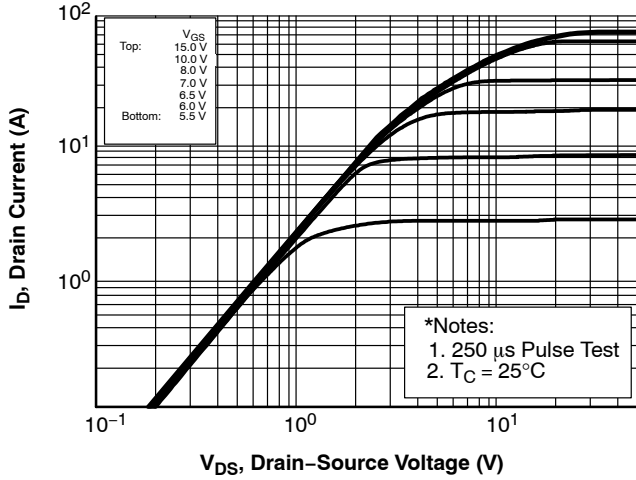

Figure 1. On-Region Characteristics

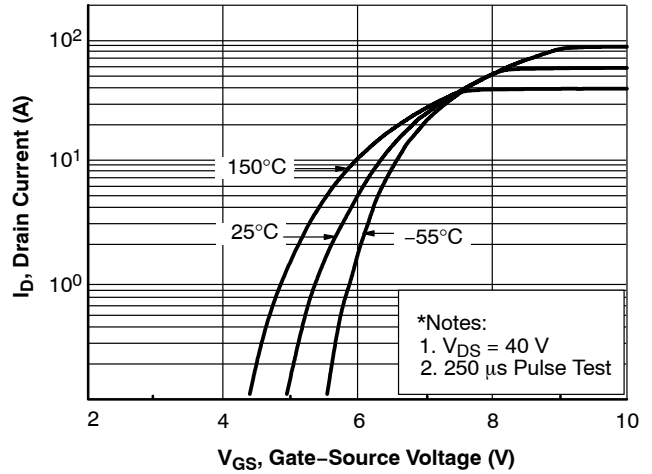

Figure 2. Transfer Characteristics

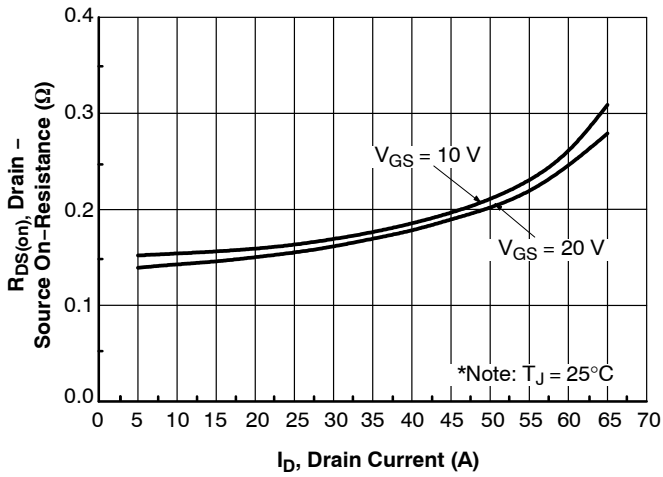

Figure 3. On-Resistance Variation vs. Drain Current and Gate Voltage

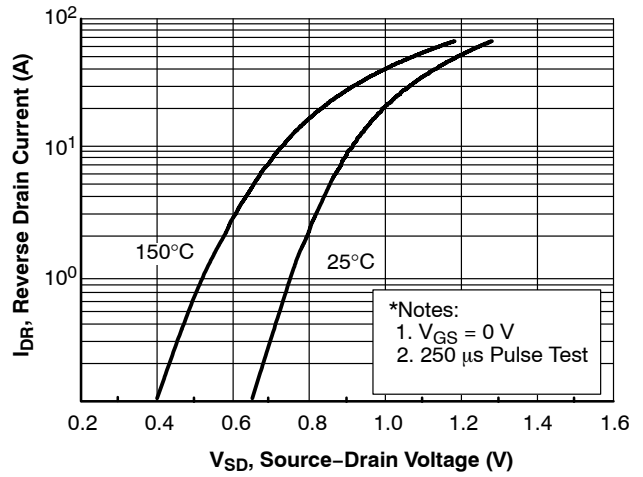

Figure 4. Body Diode Forward Voltage Variation vs. Source Current and Temperature

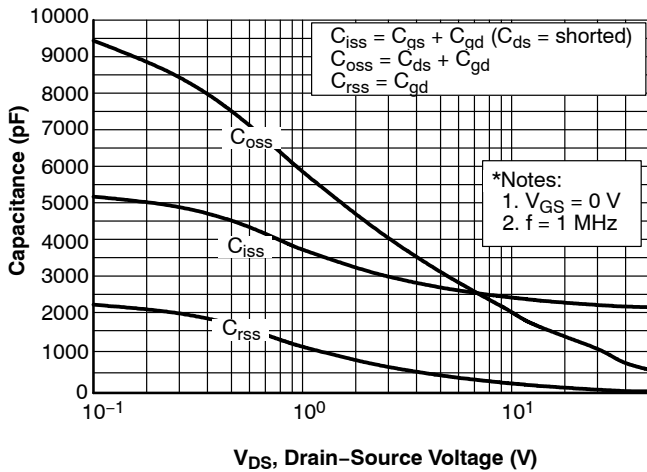

Figure 5. Capacitance Characteristics

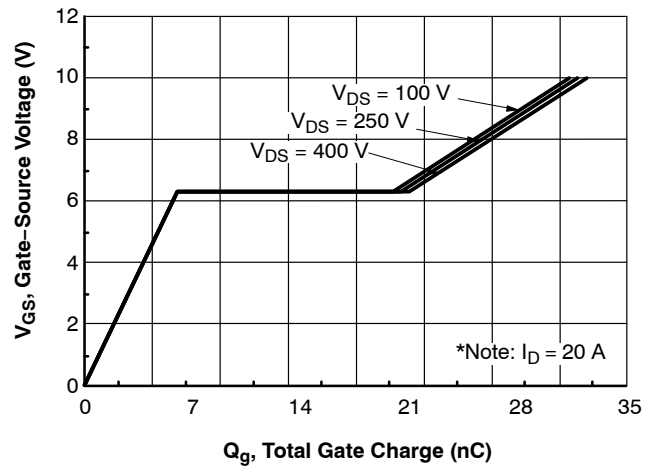

Figure 6. Gate Charge Characteristics

TYPICAL CHARACTERISTICS (CONTINUED)

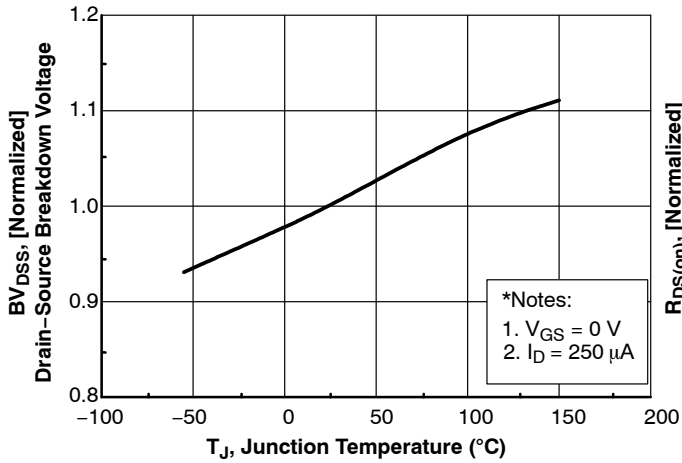

Figure 7. Breakdown Voltage Variation vs Temperature

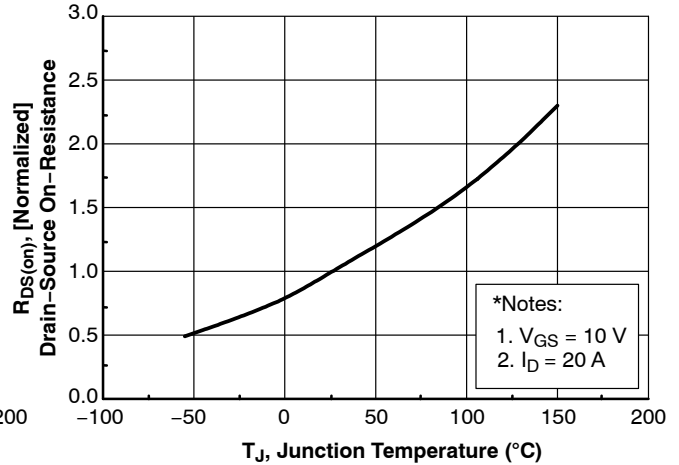

Figure 8. On-Resistance Variation vs Temperature

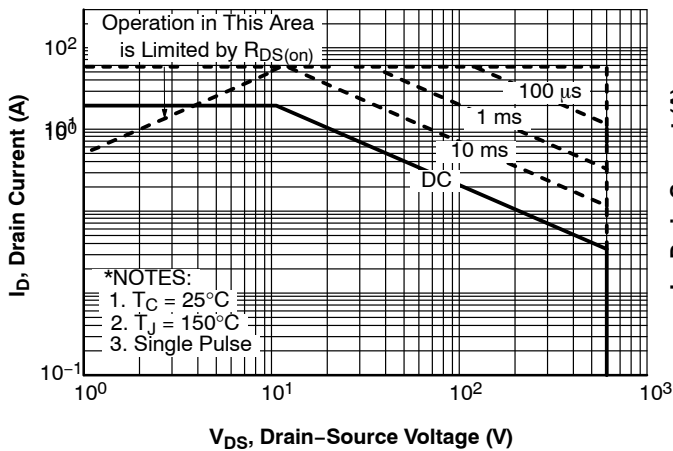

Figure 9. Maximum Safe Operating Area

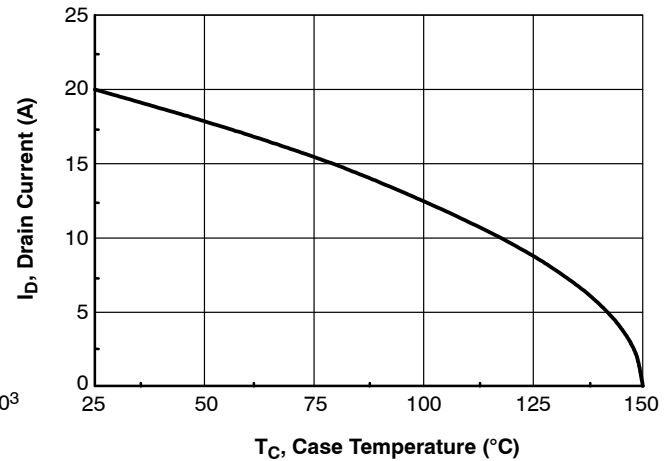

Figure 10. Maximum Drain Current vs. Case Temperature

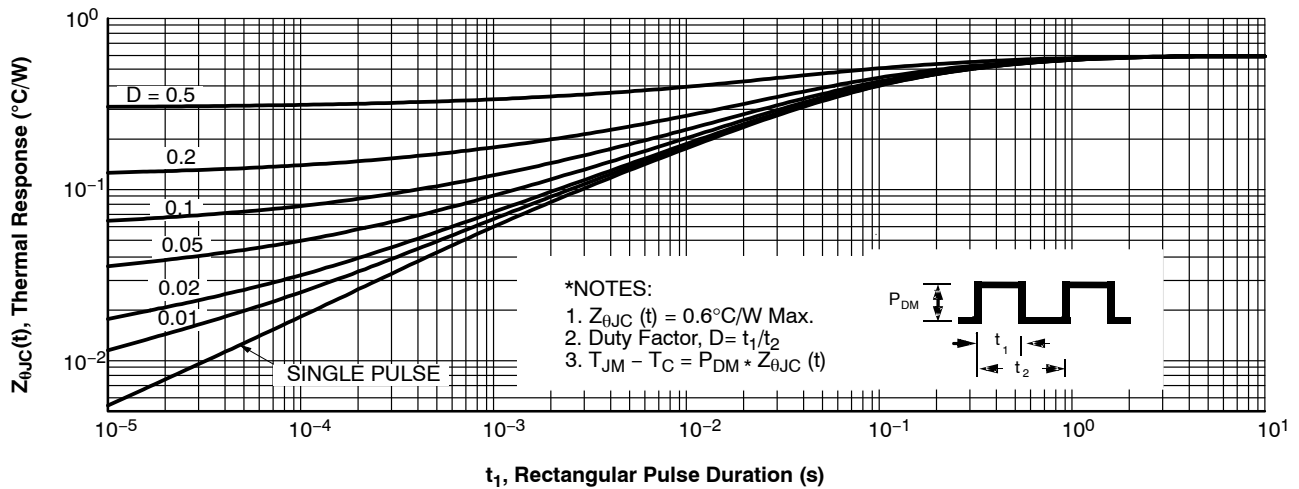

Figure 11. Transient Thermal Response Curve

FCA20N60

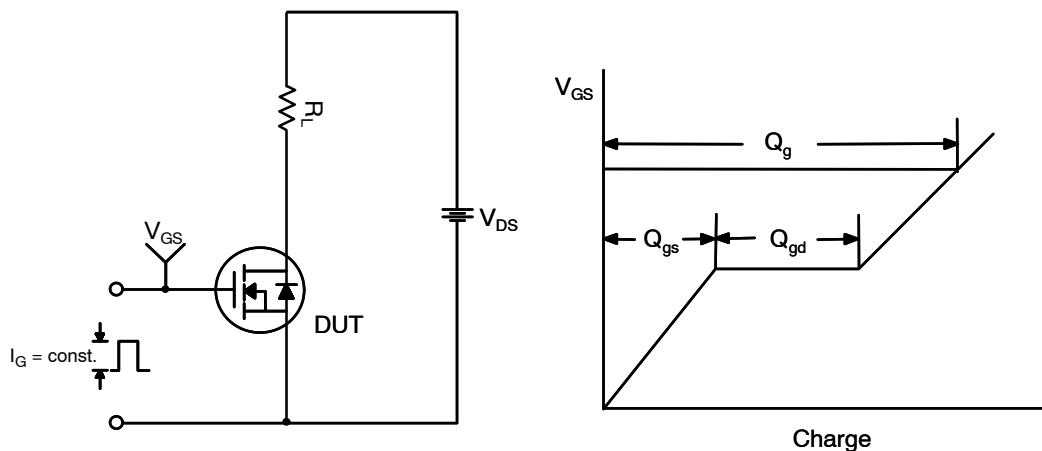

Figure 12. Gate Charge Test Circuit & Waveform

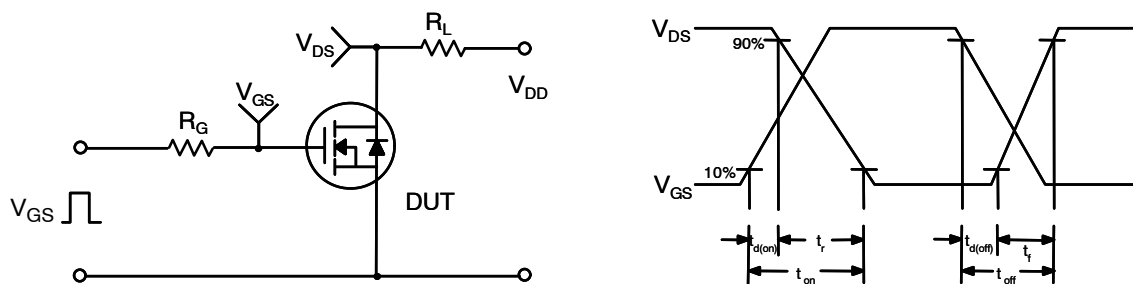

Figure 13. Resistive Switching Test Circuit & Waveforms

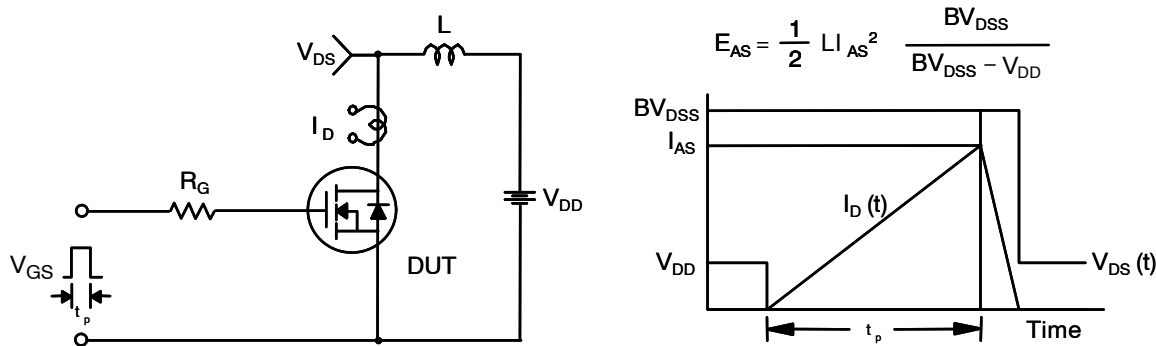

Figure 14. Unclamped Inductive Switching Test Circuit & Waveforms

FCA20N60

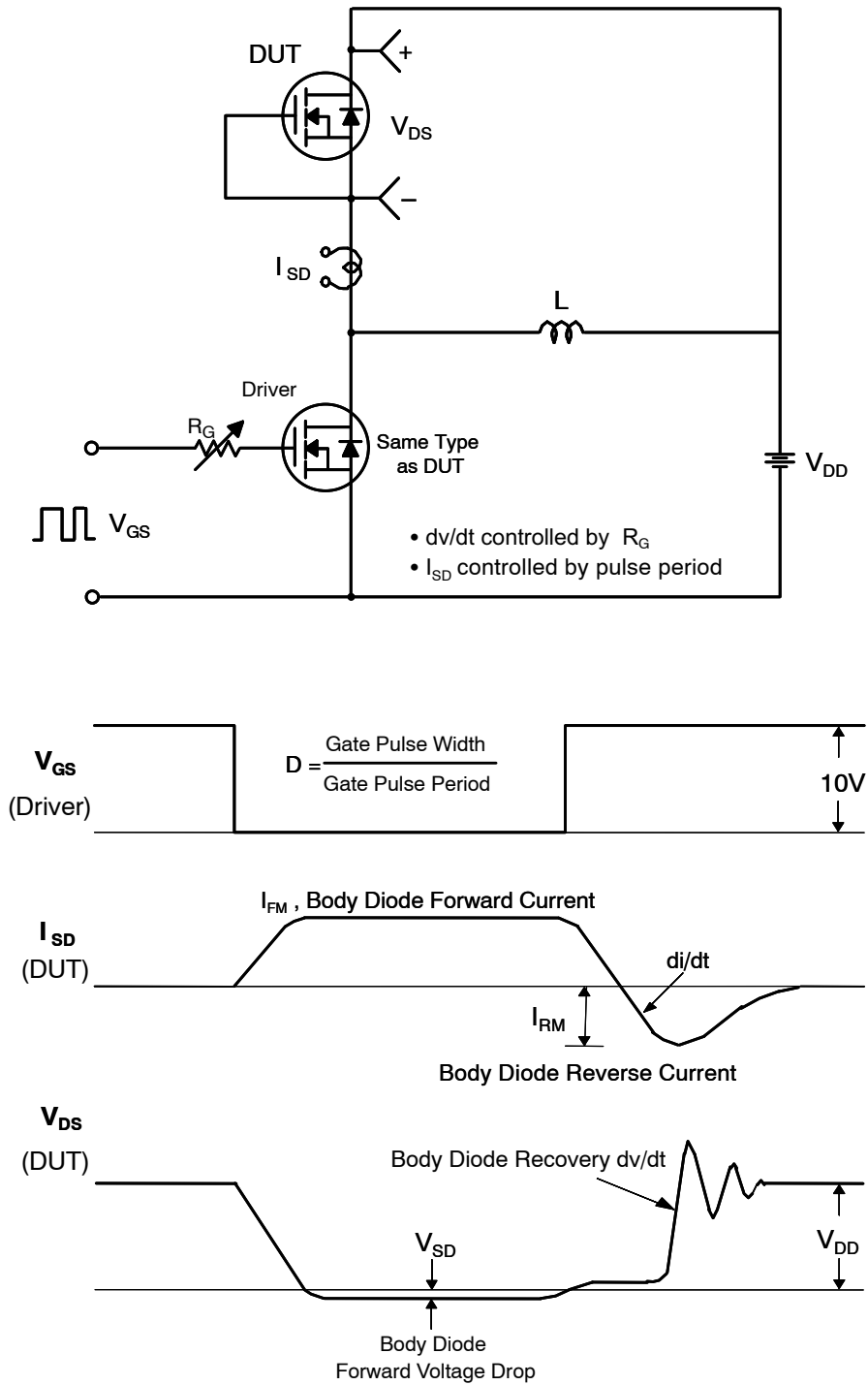

Figure 15. Peak Diode Recovery dv/dt Test Circuit & Waveforms

MECHANICAL CASE OUTLINE

PACKAGE DIMENSIONS



TO-3P-3LD / EIAJ SC-65, ISOLATED
CASE 340BZ
ISSUE O

DATE 31 OCT 2016

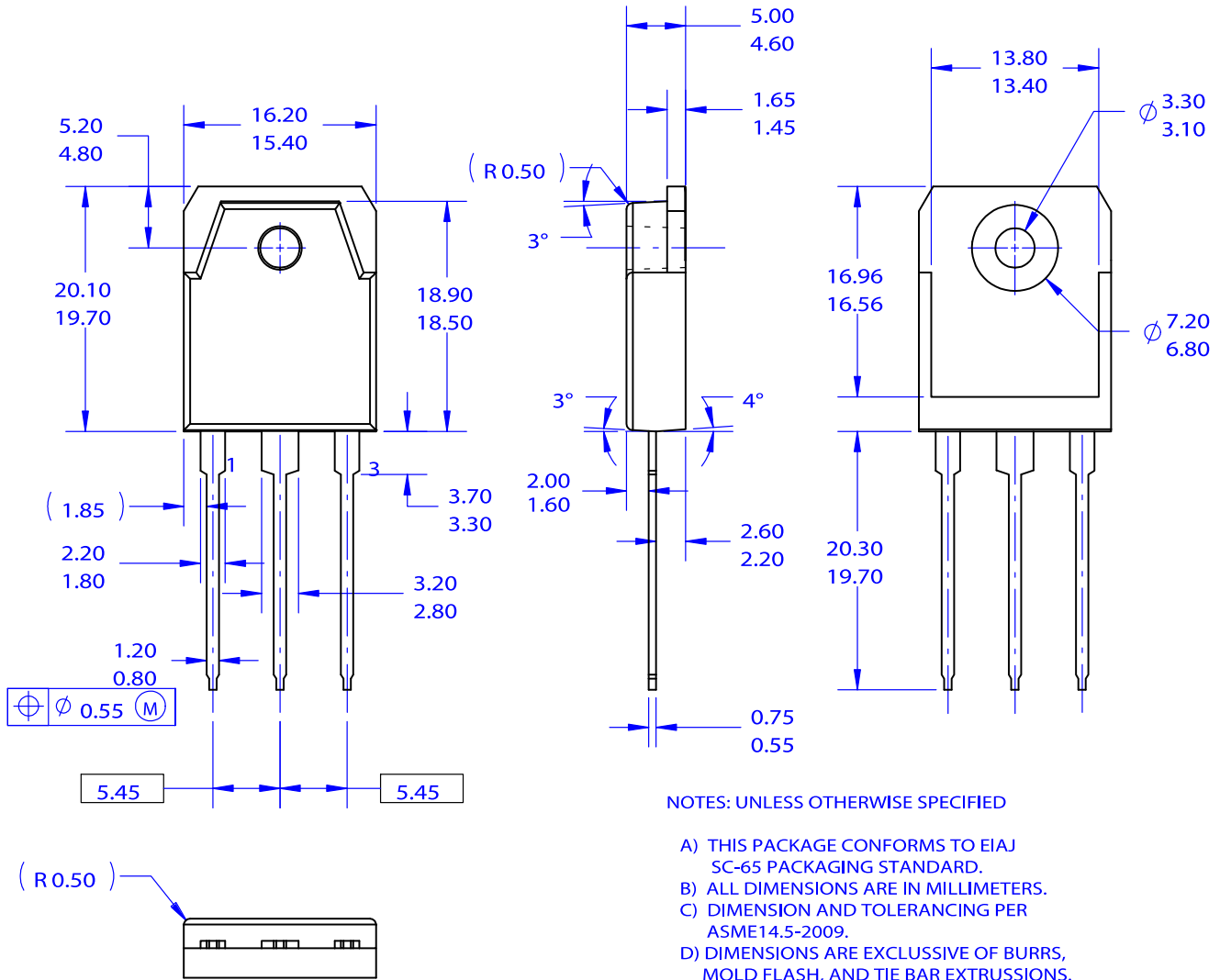

DOCUMENT NUMBER:	98AON13862G	Electronic versions are uncontrolled except when accessed directly from the Document Repository. Printed versions are uncontrolled except when stamped "CONTROLLED COPY" in red.
DESCRIPTION:	TO-3P-3LD / EIAJ SC-65, ISOLATED	PAGE 1 OF 1

ON Semiconductor and are trademarks of Semiconductor Components Industries, LLC dba ON Semiconductor or its subsidiaries in the United States and/or other countries. ON Semiconductor reserves the right to make changes without further notice to any products herein. ON Semiconductor makes no warranty, representation or guarantee regarding the suitability of its products for any particular purpose, nor does ON Semiconductor assume any liability arising out of the application or use of any product or circuit, and specifically disclaims any and all liability, including without limitation special, consequential or incidental damages. ON Semiconductor does not convey any license under its patent rights nor the rights of others.

onsemi, **Onsemi**, and other names, marks, and brands are registered and/or common law trademarks of Semiconductor Components Industries, LLC dba "**onsemi**" or its affiliates and/or subsidiaries in the United States and/or other countries. **onsemi** owns the rights to a number of patents, trademarks, copyrights, trade secrets, and other intellectual property. A listing of **onsemi**'s product/patent coverage may be accessed at www.onsemi.com/site/pdf/Patent-Marking.pdf. **onsemi** reserves the right to make changes at any time to any products or information herein, without notice. The information herein is provided "as-is" and **onsemi** makes no warranty, representation or guarantee regarding the accuracy of the information, product features, availability, functionality, or suitability of its products for any particular purpose, nor does **onsemi** assume any liability arising out of the application or use of any product or circuit, and specifically disclaims any and all liability, including without limitation special, consequential or incidental damages. Buyer is responsible for its products and applications using **onsemi** products, including compliance with all laws, regulations and safety requirements or standards, regardless of any support or applications information provided by **onsemi**. "Typical" parameters which may be provided in **onsemi** data sheets and/or specifications can and do vary in different applications and actual performance may vary over time. All operating parameters, including "Typicals" must be validated for each customer application by customer's technical experts. **onsemi** does not convey any license under any of its intellectual property rights nor the rights of others. **onsemi** products are not designed, intended, or authorized for use as a critical component in life support systems or any FDA Class 3 medical devices or medical devices with a same or similar classification in a foreign jurisdiction or any devices intended for implantation in the human body. Should Buyer purchase or use **onsemi** products for any such unintended or unauthorized application, Buyer shall indemnify and hold **onsemi** and its officers, employees, subsidiaries, affiliates, and distributors harmless against all claims, costs, damages, and expenses, and reasonable attorney fees arising out of, directly or indirectly, any claim of personal injury or death associated with such unintended or unauthorized use, even if such claim alleges that **onsemi** was negligent regarding the design or manufacture of the part. **onsemi** is an Equal Opportunity/Affirmative Action Employer. This literature is subject to all applicable copyright laws and is not for resale in any manner.

ADDITIONAL INFORMATION

TECHNICAL PUBLICATIONS:

Technical Library: www.onsemi.com/design/resources/technical-documentation
onsemi Website: www.onsemi.com

ONLINE SUPPORT: www.onsemi.com/support

For additional information, please contact your local Sales Representative at www.onsemi.com/support/sales