

3.0 Ampere Glass Passivated High Efficiency Rectifiers

EGP30A, EGP30B, EGP30C, EGP30D, EGP30F, EGP30G, EGP30J, EGP30K



COLOR BAND DENOTES CATHODE

AXIAL LEAD
(DO-201AD Glass Case)
CASE 017AF

Features

- Glass Passivated Cavity-free Junction
- High Surge Current Capability
- Low Leakage Current
- Superfast Recovery Time for High Efficiency
- Low Forward Voltage, High Current Capability
- These Devices are Pb-Free, Halide Free and are RoHS Compliant

ABSOLUTE MAXIMUM RATINGS (T_a = 25°C unless otherwise noted)

Symbol	Parameter	Value	Unit
I _O	Average Rectified Current .375" Lead Length @ T _L = 55°C	3.0	A
I _{f(surge)}	Peak Forward Surge Current 8.3 ms Single Half-sine-wave Superimposed on Rated Load (JEDEC Method)	125	A
P _D	Total Device Dissipation Derate Above 25°C	6.25 50	W mW/°C
R _{θJA}	Thermal Resistance, Junction to Ambient	20	°C/W
R _{θJL}	Thermal Resistance, Junction to Lead	8.5	°C/W
T _J , T _{STG}	Junction and Storage Temperature Range	-65~150	°C

Stresses exceeding those listed in the Maximum Ratings table may damage the device. If any of these limits are exceeded, device functionality should not be assumed, damage may occur and reliability may be affected.

MARKING DIAGRAM

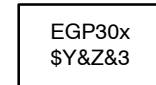

EGP30x = Specific Device Code (x = A, B, C, D, F, G, J, K)

\$Y = Logo

&Z = Assembly Plant Code

&3 = 3-Digit Date Code

ORDERING INFORMATION

Device	Package	Shipping [†]
EGP30A	AXIAL LEAD (DO-201AD Glass Case) (Pb-Free, Halide Free)	1250 / Tape & Reel
EGP30D		
EGP30F		
EGP30G		
EGP30J		
EGP30K		

DISCONTINUED (Note 1)

EGP30B	AXIAL LEAD (DO-201AD Glass Case) (Pb-Free, Halide Free)	1250 / Tape & Reel
EGP30C		

[†]For information on tape and reel specifications, including part orientation and tape sizes, please refer to our Tape and Reel Packaging Specifications Brochure, [BRD8011/D](#).

1. **DISCONTINUED:** These devices are not recommended for new design. Please contact your **onsemi** representative for information. The most current information on these devices may be available on www.onsemi.com.

EGP30A, EGP30B, EGP30C, EGP30D, EGP30F, EGP30G, EGP30J, EGP30K

ELECTRICAL CHARACTERISTICS* ($T_a = 25^\circ\text{C}$ unless otherwise noted)

Parameter	Device								Unit
	30A	30B	30C	30D	30F	30G	30J	30K	
Peak Repetitive Reverse Voltage	50	100	150	200	300	400	600	800	V
Maximum RMS Voltage	35	70	105	140	210	280	420	560	V
DC Reverse Voltage (Rated V_R)	50	100	150	200	300	400	600	800	V
Maximum Reverse Current @ Rated V_R $T_A = 25^\circ\text{C}$ $T_A = 125^\circ\text{C}$	5.0 100								μA μA
Maximum Reverse Recovery Time $I_F = 0.5\text{ A}$, $I_R = 1.0\text{ A}$, $I_{rr} = 0.25\text{ A}$	50						75		nS
Maximum Forward Voltage @ 3.0 A	0.95				1.25		1.7		V
Typical Junction Capacitance $V_R = 4.0\text{ V}$, $f = 1.0\text{ MHz}$	95				75				pF

Product parametric performance is indicated in the Electrical Characteristics for the listed test conditions, unless otherwise noted. Product performance may not be indicated by the Electrical Characteristics if operated under different conditions.

*Pulse Test: Pulse Width $\leq 300\ \mu\text{s}$, Duty Cycle $\leq 2\%$

TYPICAL CHARACTERISTICS

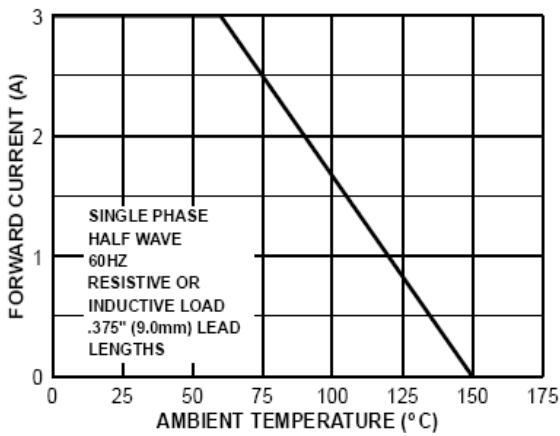

Figure 1. Forward Current Derating Curve

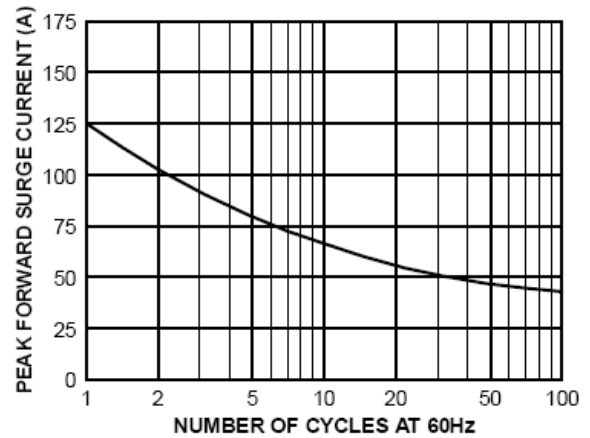

Figure 2. Non-Repetitive Surge Current

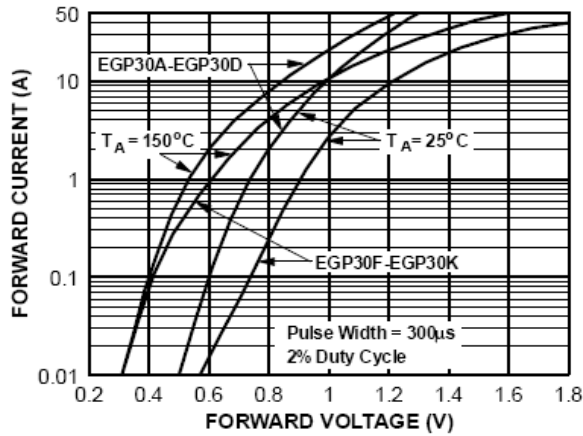

Figure 3. Forward Characteristics

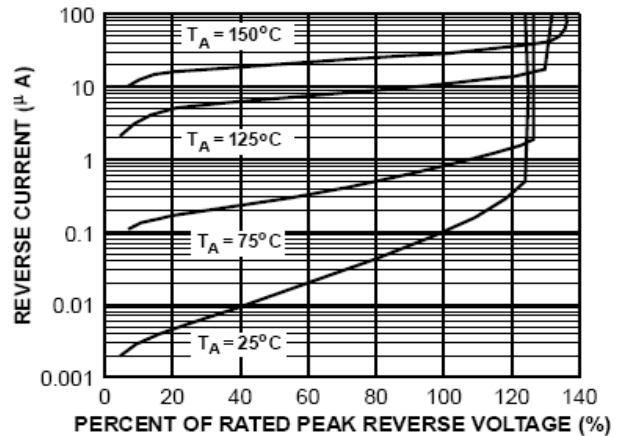

Figure 4. Reverse Characteristics

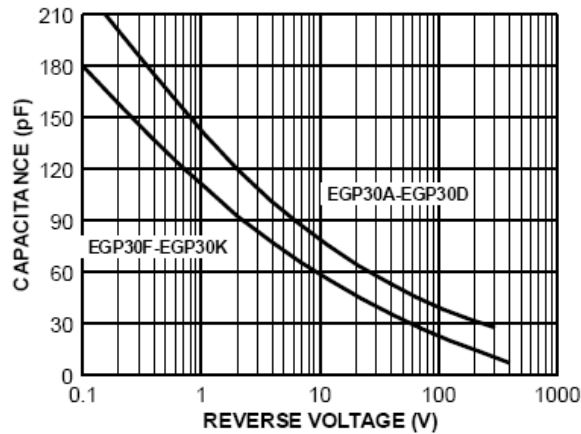
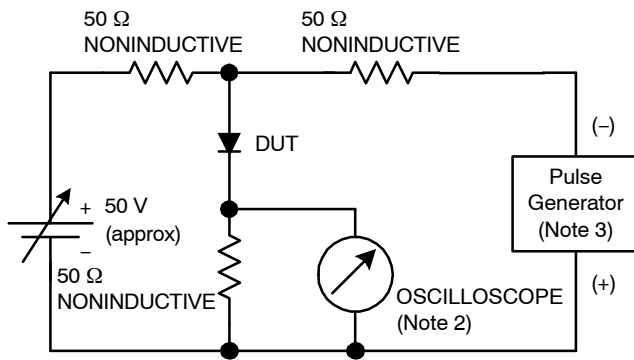

Figure 5. Junction Capacitance

REVERSE RECOVERY TIME CHARACTERISTIC AND TEST CIRCUIT DIAGRAM



NOTES:

2. Rise time = 7.0 ns max; Input impedance = 1.0 MΩ 22 pF.
3. Rise time = 10 ns max; Source impedance = 50 Ω.

Figure 6. Test Circuit Diagram

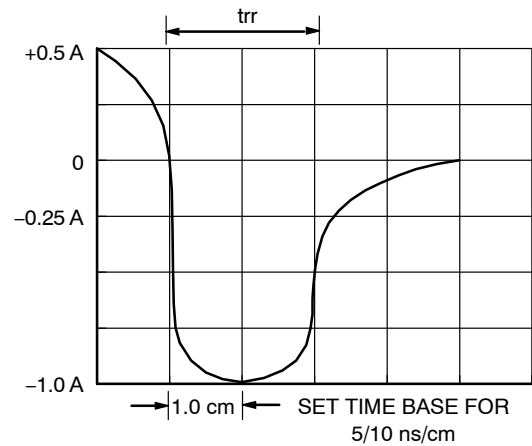
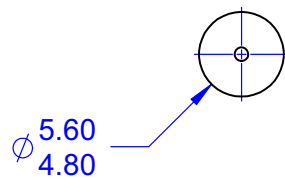
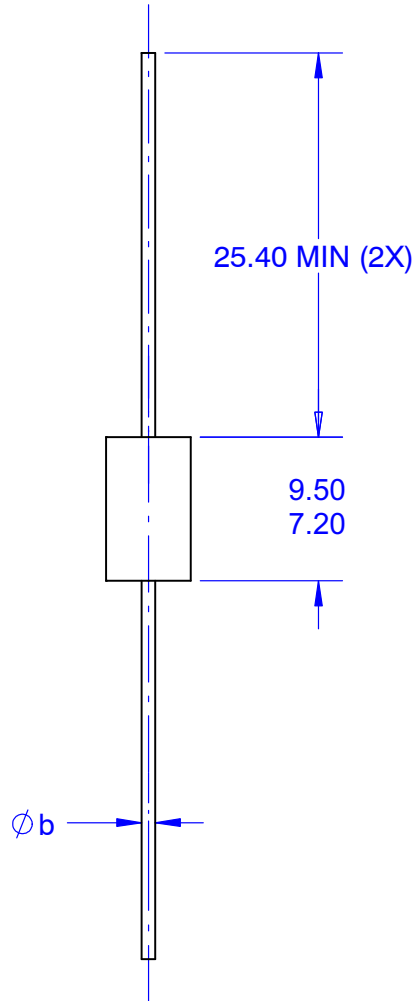

Figure 7. Reverse Recovery Time Characteristic

AXIAL LEAD
CASE 017AF
ISSUE 0

DATE 31 AUG 2016



NOTES: UNLESS OTHERWISE SPECIFIED

- A) PACKAGE STANDARD REFERENCE: JEDEC DO-201 VARIATION AD.
- B) PLASTIC PACKAGE BODY.
- C) ALL DIMENSIONS ARE IN MILLIMETERS.
- D) ϕb DIMENSION REPRESENT LIKE BELOW:
 OPTION AD = 1.20MIN TO 1.30MAX
 OPTION AE = 0.94MIN TO 1.07MAX

DOCUMENT NUMBER:	98AON13438G	Electronic versions are uncontrolled except when accessed directly from the Document Repository. Printed versions are uncontrolled except when stamped "CONTROLLED COPY" in red.
DESCRIPTION:	AXIAL LEAD	PAGE 1 OF 1

onsemi and ONSEMI are trademarks of Semiconductor Components Industries, LLC dba onsemi or its subsidiaries in the United States and/or other countries. onsemi reserves the right to make changes without further notice to any products herein. onsemi makes no warranty, representation or guarantee regarding the suitability of its products for any particular purpose, nor does onsemi assume any liability arising out of the application or use of any product or circuit, and specifically disclaims any and all liability, including without limitation special, consequential or incidental damages. onsemi does not convey any license under its patent rights nor the rights of others.

onsemi, **Onsemi**, and other names, marks, and brands are registered and/or common law trademarks of Semiconductor Components Industries, LLC dba "**onsemi**" or its affiliates and/or subsidiaries in the United States and/or other countries. **onsemi** owns the rights to a number of patents, trademarks, copyrights, trade secrets, and other intellectual property. A listing of **onsemi**'s product/patent coverage may be accessed at www.onsemi.com/site/pdf/Patent-Marking.pdf. **onsemi** reserves the right to make changes at any time to any products or information herein, without notice. The information herein is provided "as-is" and **onsemi** makes no warranty, representation or guarantee regarding the accuracy of the information, product features, availability, functionality, or suitability of its products for any particular purpose, nor does **onsemi** assume any liability arising out of the application or use of any product or circuit, and specifically disclaims any and all liability, including without limitation special, consequential or incidental damages. Buyer is responsible for its products and applications using **onsemi** products, including compliance with all laws, regulations and safety requirements or standards, regardless of any support or applications information provided by **onsemi**. "Typical" parameters which may be provided in **onsemi** data sheets and/or specifications can and do vary in different applications and actual performance may vary over time. All operating parameters, including "Typicals" must be validated for each customer application by customer's technical experts. **onsemi** does not convey any license under any of its intellectual property rights nor the rights of others. **onsemi** products are not designed, intended, or authorized for use as a critical component in life support systems or any FDA Class 3 medical devices or medical devices with a same or similar classification in a foreign jurisdiction or any devices intended for implantation in the human body. Should Buyer purchase or use **onsemi** products for any such unintended or unauthorized application, Buyer shall indemnify and hold **onsemi** and its officers, employees, subsidiaries, affiliates, and distributors harmless against all claims, costs, damages, and expenses, and reasonable attorney fees arising out of, directly or indirectly, any claim of personal injury or death associated with such unintended or unauthorized use, even if such claim alleges that **onsemi** was negligent regarding the design or manufacture of the part. **onsemi** is an Equal Opportunity/Affirmative Action Employer. This literature is subject to all applicable copyright laws and is not for resale in any manner.

ADDITIONAL INFORMATION

TECHNICAL PUBLICATIONS:

Technical Library: www.onsemi.com/design/resources/technical-documentation
onsemi Website: www.onsemi.com

ONLINE SUPPORT: www.onsemi.com/support

For additional information, please contact your local Sales Representative at www.onsemi.com/support/sales