

Linear Voltage Tracking Regulator - Micropower Low Dropout, Line Driver

200 mA

CS8182

The CS8182 is a monolithic integrated low dropout tracking regulator designed to provide an adjustable buffered output voltage that closely tracks (± 10 mV) the reference input. The output delivers up to 200 mA while being able to be configured higher, lower or equal to the reference voltages.

The device has been designed to operate over a wide range (2.8 V to 45 V) while still maintaining excellent DC characteristics. The CS8182 is protected from reverse battery, short circuit and thermal runaway conditions. The device also can withstand 45 V load dump transients and -50 V reverse polarity input voltage transients. This makes it suitable for use in automotive environments.

The $V_{REF}/ENABLE$ lead serves two purposes. It is used to provide the input voltage as a reference for the output and it also can be pulled low to place the device in sleep mode where it nominally draws 30 μ A from the supply.

Features

- 200 mA Source Capability
- Output Tracks within ± 10 mV Worst Case
- Low Dropout (0.35 V Typ. @ 200 mA)
- Low Quiescent Current
- Thermal Shutdown
- Short Circuit Protection
- Wide Operating Range
- Internally Fused Leads in SO-8 Package
- For Automotive and Other Applications Requiring Site and Change Control
- These are Pb-Free Devices

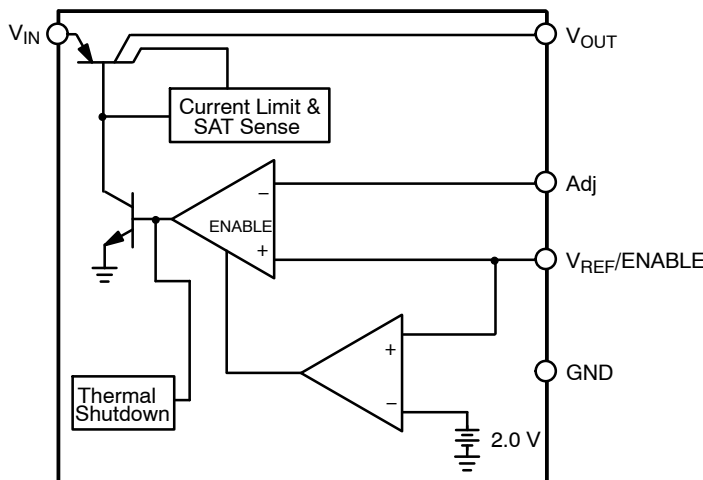
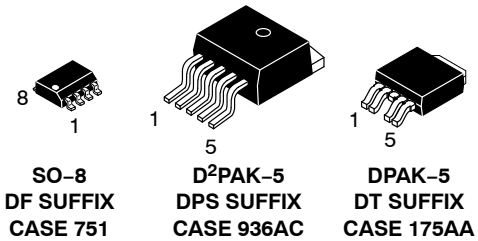
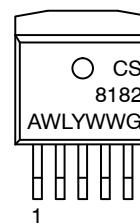
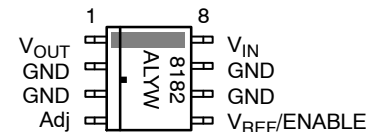

Figure 1. Block Diagram



PIN CONNECTIONS AND MARKING DIAGRAMS



- Tab GND
Pin 1. V_{IN}
2. V_{OUT}
3. GND
4. Adj
5. V_{REF}

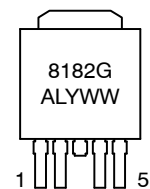

- A = Assembly Location
WL, L = Wafer Lot
Y = Year
WW, W = Work Week
G or ■ = Pb-Free Device

ORDERING INFORMATION

See detailed ordering and shipping information in the package dimensions section on page 9 of this data sheet.

NOTE: Some of the devices on this data sheet have been **DISCONTINUED**. Please refer to the table on page 9.

PACKAGE PIN DESCRIPTION

Package Lead Number			Lead Symbol	Function
SO-8	D ² PAK 5-PIN	DPAK 5-PIN		
8	1	1	V _{IN}	Input Voltage
1	2	2	V _{OUT}	Regulated Output
2, 3, 6, 7	3	3	GND	Ground
4	4	4	Adj	Adjust Lead
5	5	5	V _{REF/ENABLE}	Reference Voltage and ENABLE Input

MAXIMUM RATINGS

Rating	Value	Unit
Storage Temperature Range	-65 to +150	°C
Junction Temperature	+150	°C
Supply Voltage Range (Continuous)	-16 to 45	V
Peak Transient Voltage (V _{IN} = 14 V, Load Dump Transient = 31 V)	45	V
Voltage Range (Adj, V _{OUT} , V _{REF/ENABLE})	-10 to +V _{IN}	V
Package Thermal Resistance, SO-8: Junction-to-Case, R _{θJC} Junction-to-Air, R _{θJA}	25 80	°C/W °C/W
Package Thermal Resistance, D ² PAK Junction-to-Case, R _{θJC} Junction-to-Air, R _{θJA}	4.0 48	°C/W °C/W
Package Thermal Resistance, DPAK Junction-to-Case, R _{θJC} Junction-to-Air, R _{θJA}	8.0 64	°C/W °C/W
ESD Capability (Human Body Model) (Machine Model)	2.0 200	kV V
Lead Temperature Soldering: (Note 1)	(SO-8) (D ² PAK) (DPAK) 240 225 260	°C

Stresses exceeding those listed in the Maximum Ratings table may damage the device. If any of these limits are exceeded, device functionality should not be assumed, damage may occur and reliability may be affected.

1. 60 second maximum above 183°C.

RECOMMENDED OPERATING RANGES

Rating	Value	Unit
Junction Temperature, T _J	-40 to +125	°C
Input Voltage, Continuous V _{IN}	3.4 to 45	V

Functional operation above the stresses listed in the Recommended Operating Ranges is not implied. Extended exposure to stresses beyond the Recommended Operating Ranges limits may affect device reliability.

CS8182

ELECTRICAL CHARACTERISTICS ($V_{IN} = 14\text{ V}$; $V_{REF}/ENABLE > 2.75\text{ V}$; $-40^{\circ}\text{C} < T_J < +125^{\circ}\text{C}$; $C_{OUT} \geq 10\ \mu\text{F}$; $0.1\ \Omega < C_{OUT-ESR} < 1.0\ \Omega @ 10\text{ kHz}$, unless otherwise specified.)

Parameter	Test Conditions	Min	Typ	Max	Unit
Regular Output					
$V_{REF} - V_{OUT}$ V_{OUT} Tracking Error	$4.5\text{ V} \leq V_{IN} \leq 26\text{ V}$, $100\ \mu\text{A} \leq I_{OUT} \leq 200\text{ mA}$, Note 2 $V_{IN} = 12\text{ V}$, $I_{OUT} = 30\text{ mA}$, $V_{REF} = 5.0\text{ V}$, Note 2	-10	-	10	mV
		-5.0	-	5	mV
Dropout Voltage ($V_{IN} - V_{OUT}$)	$I_{OUT} = 100\ \mu\text{A}$ $I_{OUT} = 30\text{ mA}$ $I_{OUT} = 200\text{ mA}$	-	100	150	mV
		-	-	500	mV
		-	350	600	mV
Line Regulation	$4.5\text{ V} \leq V_{IN} \leq 26\text{ V}$, Note 2	-	-	10	mV
Load Regulation	$100\ \mu\text{A} \leq I_{OUT} \leq 200\text{ mA}$, Note 2	-	-	10	mV
Adj Lead Current	Loop in Regulation	-	0.2	1.0	μA
Current Limit	$V_{IN} = 14\text{ V}$, $V_{REF} = 5.0\text{ V}$, $V_{OUT} = 90\%$ of V_{REF} , Note 2	250	-	700	mA
Quiescent Current ($I_{IN} - I_{OUT}$)	$V_{IN} = 12\text{ V}$, $I_{OUT} = 200\text{ mA}$ $V_{IN} = 12\text{ V}$, $I_{OUT} = 100\ \mu\text{A}$ $V_{IN} = 12\text{ V}$, $V_{REF}/ENABLE = 0\text{ V}$	-	15	25	mA
		-	75	150	μA
		-	30	55	μA
Reverse Current	$V_{OUT} = 5.0\text{ V}$, $V_{IN} = 0\text{ V}$	-	0.2	1.5	mA
Ripple Rejection	$f = 120\text{ Hz}$, $I_{OUT} = 200\text{ mA}$, $4.5\text{ V} \leq V_{IN} \leq 26\text{ V}$	60	-	-	dB
Thermal Shutdown	GBD	150	180	210	$^{\circ}\text{C}$

$V_{REF}/ENABLE$

Enable Voltage	-	0.80	2.00	2.75	V
Input Bias Current	$V_{REF}/ENABLE$	-	0.2	1.0	μA

Product parametric performance is indicated in the Electrical Characteristics for the listed test conditions, unless otherwise noted. Product performance may not be indicated by the Electrical Characteristics if operated under different conditions.

2. V_{OUT} connected to Adj lead.

TYPICAL CHARACTERISTICS

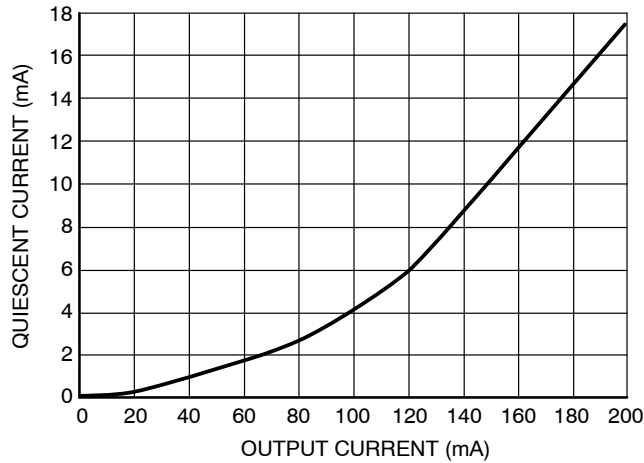

Figure 2. Quiescent Current vs. Output Current

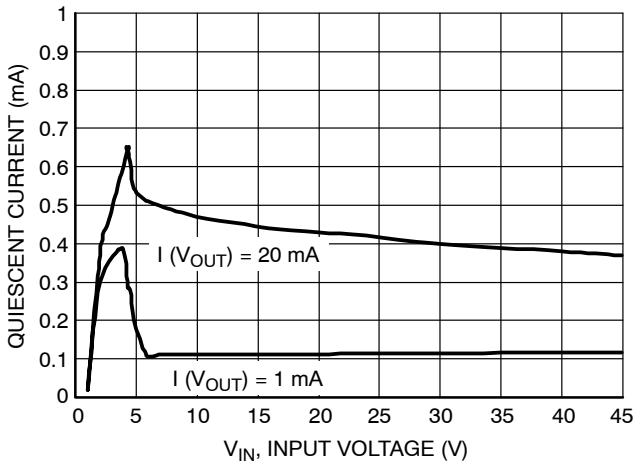

Figure 3. Quiescent Current vs. Input Voltage (Operating Mode)

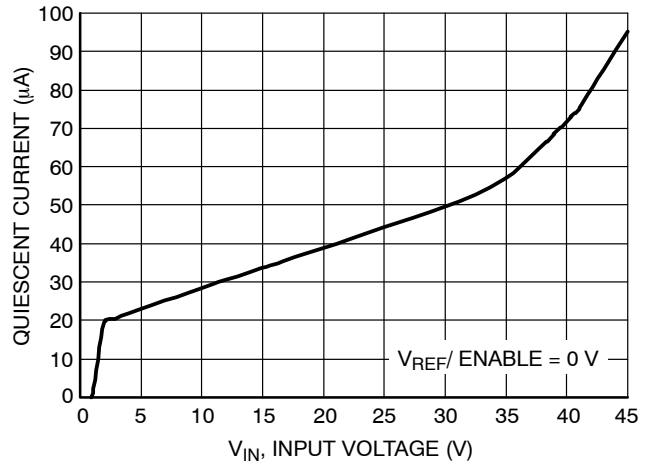

Figure 4. Quiescent Current vs. Input Voltage (Sleep Mode)

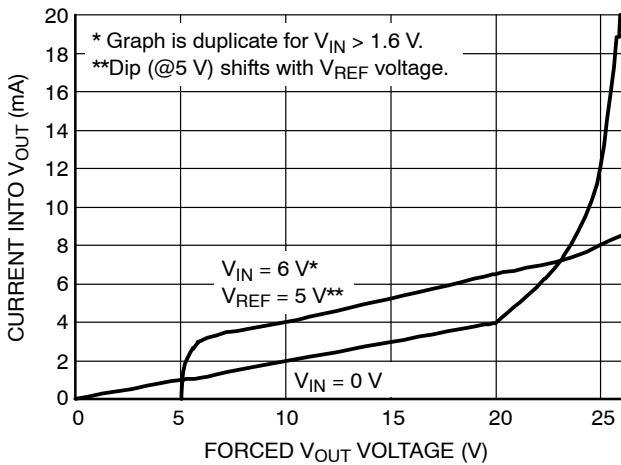

Figure 5. V_{OUT} Reverse Current

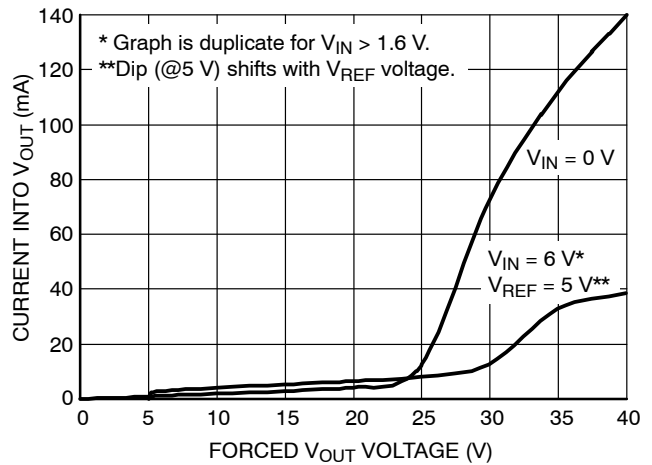

Figure 6. V_{OUT} Reverse Current

CIRCUIT DESCRIPTION

ENABLE Function

By pulling the V_{REF}/ENABLE lead below 2.0 V typically, (see Figure 10 or Figure 11), the IC is disabled and enters a sleep state where the device draws less than 55 μA from supply. When the V_{REF}/ENABLE lead is greater than 2.75 V, V_{OUT} tracks the V_{REF}/ENABLE lead normally.

Output Voltage

The output is capable of supplying 200 mA to the load while configured as a similar (Figure 7), lower (Figure 9), or higher (Figure 8) voltage as the reference lead. The Adj lead acts as the inverting terminal of the op amp and the V_{REF} lead as the non-inverting.

The device can also be configured as a high-side driver as displayed in Figure 12.

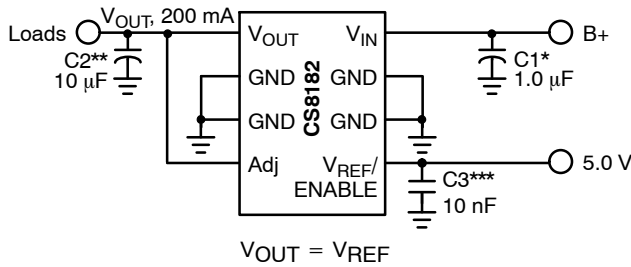

Figure 7. Tracking Regulator at the Same Voltage

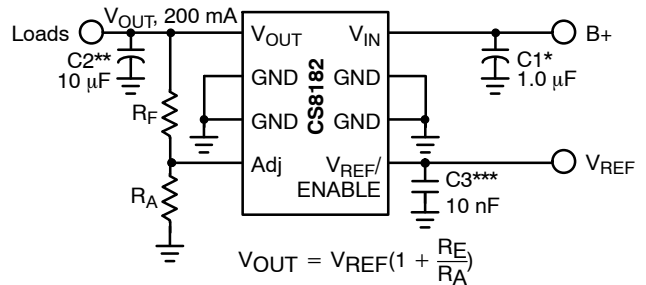

Figure 8. Tracking Regulator at Higher Voltages

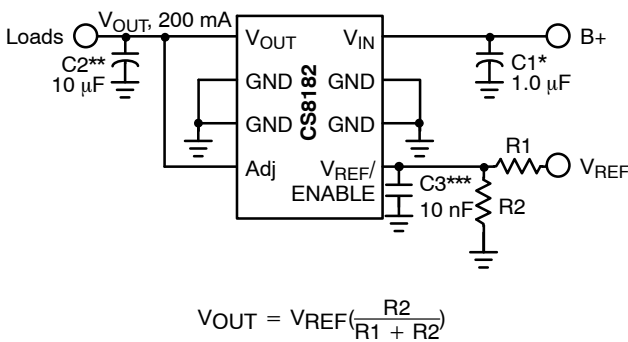

Figure 9. Tracking Regulator at Lower Voltages

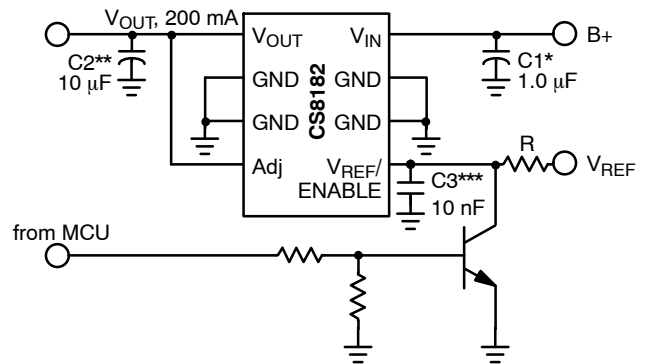

Figure 10. Tracking Regulator with ENABLE Circuit

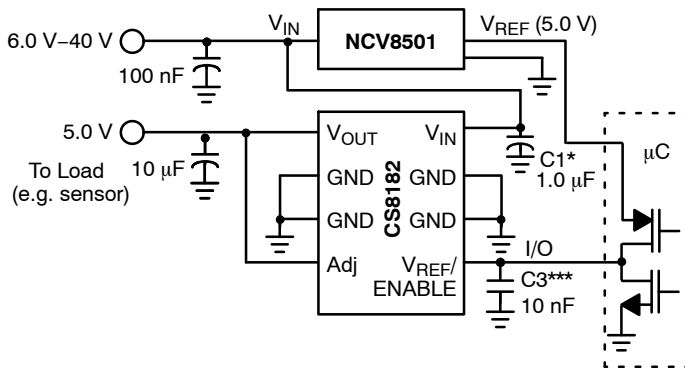

Figure 11. Alternative ENABLE Circuit

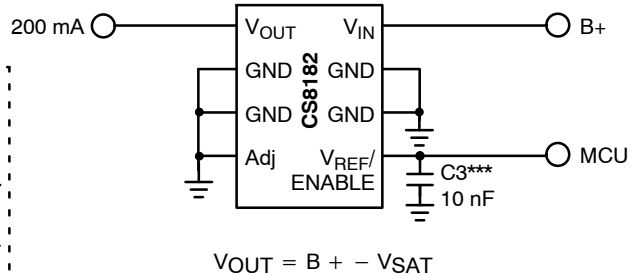

Figure 12. High-Side Driver

* C1 is required if the regulator is far from the power source filter.
 ** C2 is required for stability.
 *** C3 is recommended for EMC susceptibility.

APPLICATION NOTES

V_{OUT} Short to Battery

The CS8182 will survive a short to battery when hooked up the conventional way as shown in Figure 13. No damage to the part will occur. The part also endures a short to battery when powered by an isolated supply at a lower voltage as in

Figure 14. In this case the CS8182 supply input voltage is set at 7 V when a short to battery (14 V typical) occurs on V_{OUT} which normally runs at 5 V. The current into the device (ammeter in Figure 14) will draw additional current as displayed in Figure 15.

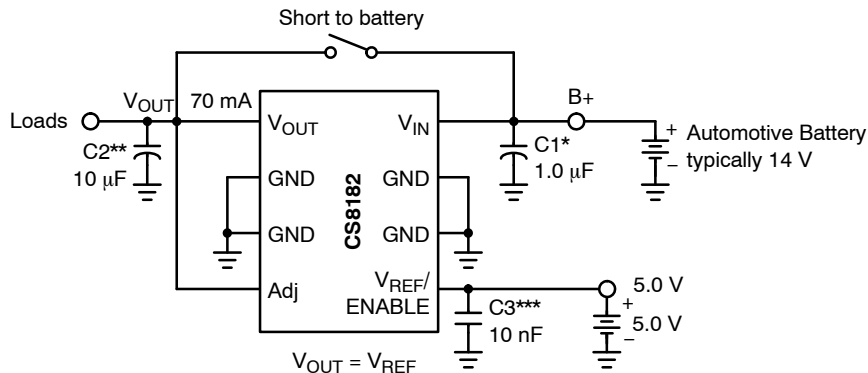
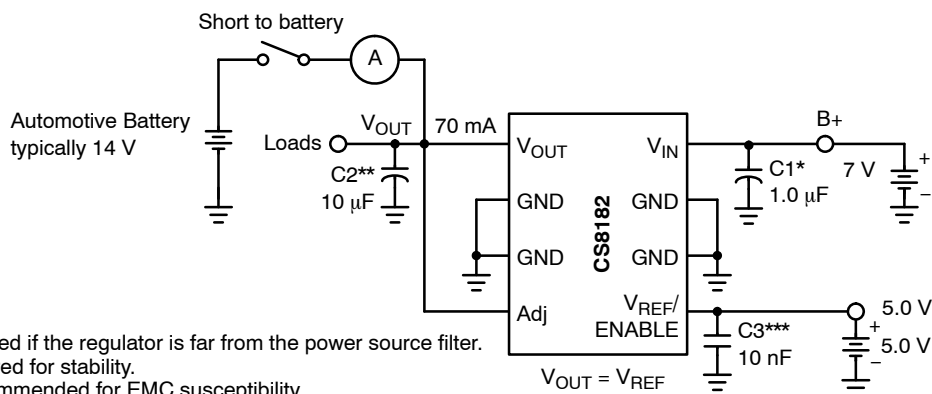

Figure 13.



* C1 is required if the regulator is far from the power source filter.
 ** C2 is required for stability.
 *** C3 is recommended for EMC susceptibility.

Figure 14.

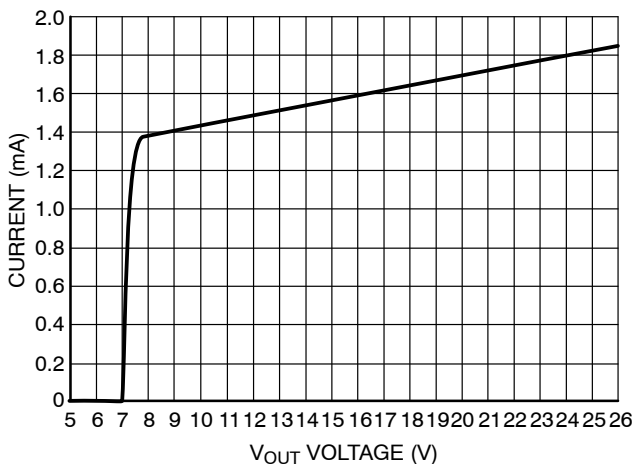

Figure 15. V_{OUT} Short to Battery

Switched Application

The CS8182 has been designed for use in systems where the reference voltage on the V_{REF/ENABLE} pin is continuously on. Typically, the current into the V_{REF/ENABLE} pin will be less than 1.0 μA when the voltage on the V_{IN} pin (usually the ignition line) has been switched out (V_{IN} can be at high impedance or at ground.) Reference Figure 16.

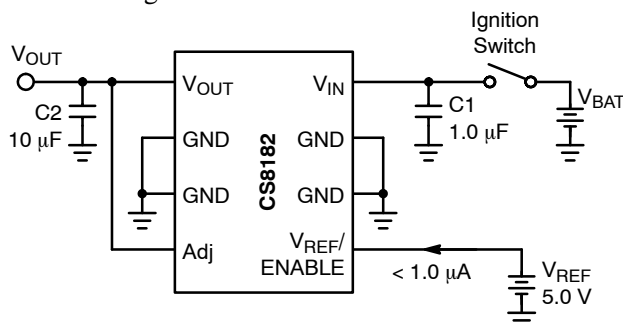

Figure 16.

External Capacitors

The output capacitor for the CS8182 is required for stability. Without it, the regulator output will oscillate. Actual size and type may vary depending upon the application load and temperature range. Capacitor effective series resistance (ESR) is also a factor in the IC stability. Worst-case is determined at the minimum ambient temperature and maximum load expected.

The output capacitor can be increased in size to any desired value above the minimum. One possible purpose of this would be to maintain the output voltage during brief conditions of negative input transients that might be characteristic of a particular system.

The capacitor must also be rated at all ambient temperatures expected in the system. To maintain regulator stability down to -40°C, a capacitor rated at that temperature must be used.

Ceramic Capacitor Stability

The CS8182 has been verified to work with ceramic output capacitors with an additional series resistor simulating traditional ESR of tantalum capacitors; however, it has been determined the best operational performance is with a 330 mΩ series resistor (or parallel combination of three 1 Ω resistors) in conjunction with a 22 μF output capacitor. Values outside of this are known to have limited performance with respect to stability. For more information, please contact your local **onsemi** sales office.

Calculating Power Dissipation in a Single Output Linear Regulator

The maximum power dissipation for a single output regulator (Figure 17) is:

$$PD(max) = \{V_{IN(max)} - V_{OUT(min)}\} I_{OUT(max)} + V_{IN(max)} I_Q \tag{1}$$

where:

- $V_{IN(max)}$ is the maximum input voltage,
- $V_{OUT(min)}$ is the minimum output voltage,
- $I_{OUT(max)}$ is the maximum output current, for the application, and
- I_Q is the quiescent current the regulator consumes at $I_{OUT(max)}$.

Once the value of PD(max) is known, the maximum permissible value of $R_{\theta JA}$ can be calculated:

$$R_{\theta JA} = \frac{150^\circ C - T_A}{PD} \tag{2}$$

The value of $R_{\theta JA}$ can then be compared with those in the package section of the data sheet. Those packages with $R_{\theta JA}$'s less than the calculated value in equation 2 will keep the die temperature below 150°C.

In some cases, none of the packages will be sufficient to dissipate the heat generated by the IC, and an external heat sink will be required.

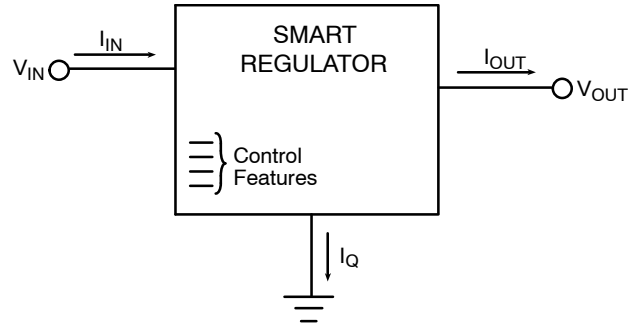

Figure 17. Single Output Regulator with Key Performance Parameters Labeled

Heatsinks

A heatsink effectively increases the surface area of the package to improve the flow of heat away from the IC and into the surrounding air.

Each material in the heat flow path between the IC and the outside environment will have a thermal resistance. Like series electrical resistances, these resistances are summed to determine the value of $R_{\theta JA}$:

$$R_{\theta JA} = R_{\theta JC} + R_{\theta CS} + R_{\theta SA} \tag{3}$$

where:

- $R_{\theta JC}$ = the junction-to-case thermal resistance,
- $R_{\theta CS}$ = the case-to-heatsink thermal resistance, and
- $R_{\theta SA}$ = the heatsink-to-ambient thermal resistance.

$R_{\theta JC}$ appears in the package section of the data sheet. Like $R_{\theta JA}$, it is a function of package type. $R_{\theta CS}$ and $R_{\theta SA}$ are functions of the package type, heatsink and the interface between them. These values appear in heat sink data sheets of heatsink manufacturers.

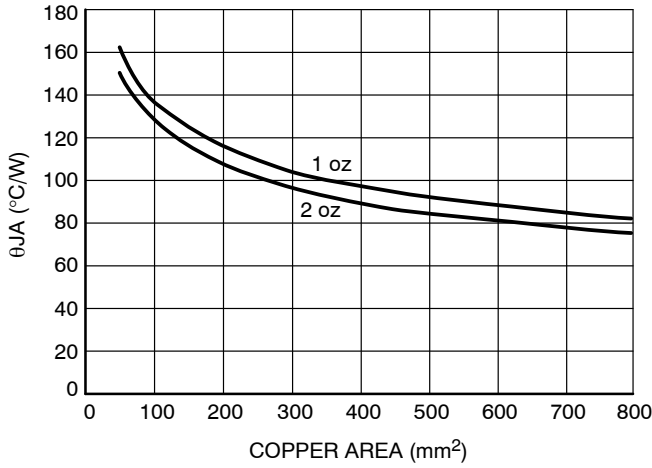

Figure 18. 8 Lead SOIC (Fused) Thermal Resistance

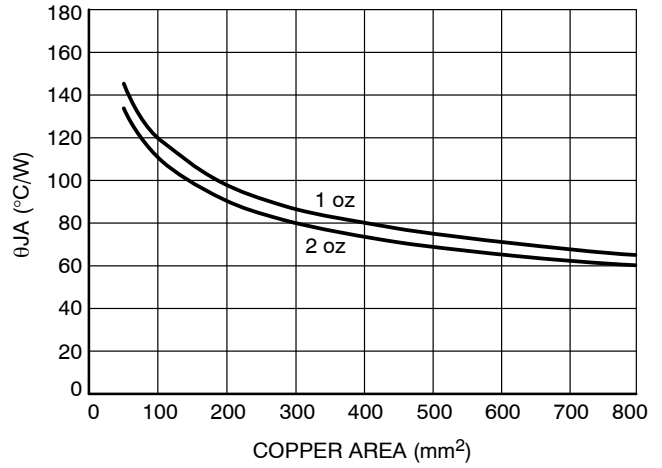

Figure 19. 5 Lead DPAK Thermal Resistance

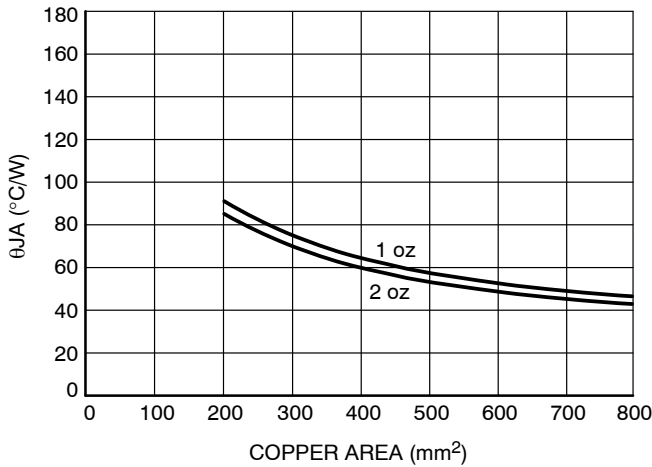

Figure 20. 5 Lead D²PAK Thermal Resistance

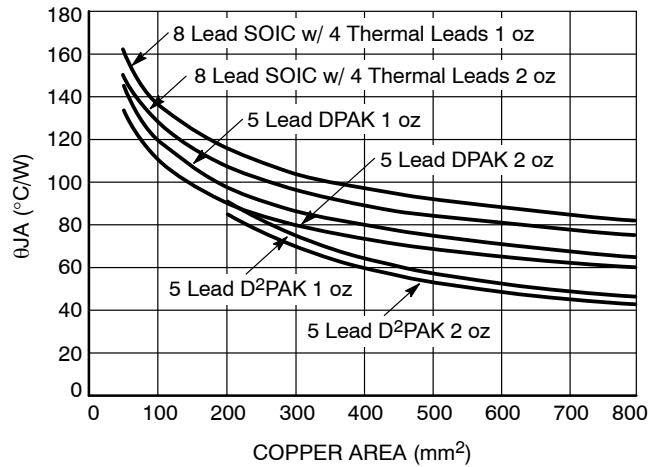

Figure 21. Thermal Resistance Summary

CS8182

ORDERING INFORMATION

Device	Package	Shipping†
CS8182YDFR8G	SO-8 (Pb-Free)	2500 / Tape & Reel

DISCONTINUED (Note 3)

CS8182YDF8G	SO-8 (Pb-Free)	95 Units / Rail
CS8182YDPS5G	D ² PAK 5-PIN (Pb-Free)	50 Units / Rail
CS8182YDPSR5G	D ² PAK 5-PIN (Pb-Free)	750 / Tape & Reel
CS8182DTG	DPAK 5L (Pb-Free)	50 Units / Rail
CS8182DTRKG	DPAK 5L (Pb-Free)	2500 / Tape & Reel

†For information on tape and reel specifications, including part orientation and tape sizes, please refer to our Tape and Reel Packaging Specifications Brochure, BRD8011/D.

3. **DISCONTINUED:** These devices are not recommended for new design. Please contact your **onsemi** representative for information. The most current information on these devices may be available on www.onsemi.com.

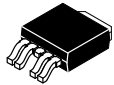

DPAK-5, CENTER LEAD CROP
CASE 175AA
ISSUE B

DATE 15 MAY 2014

SCALE 1:1

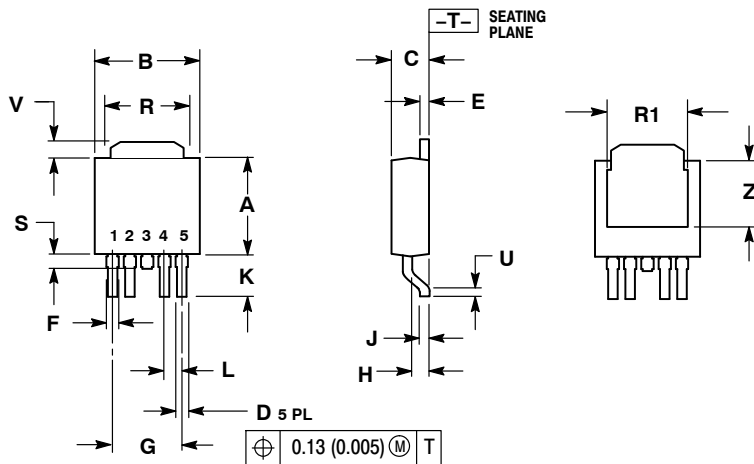

- NOTES:
1. DIMENSIONING AND TOLERANCING PER ANSI Y14.5M, 1982.
2. CONTROLLING DIMENSION: INCH.

DIM	INCHES		MILLIMETERS	
	MIN	MAX	MIN	MAX
A	0.235	0.245	5.97	6.22
B	0.250	0.265	6.35	6.73
C	0.086	0.094	2.19	2.38
D	0.020	0.028	0.51	0.71
E	0.018	0.023	0.46	0.58
F	0.024	0.032	0.61	0.81
G	0.180 BSC		4.56 BSC	
H	0.034	0.040	0.87	1.01
J	0.018	0.023	0.46	0.58
K	0.102	0.114	2.60	2.89
L	0.045 BSC		1.14 BSC	
R	0.170	0.190	4.32	4.83
R1	0.185	0.210	4.70	5.33
S	0.025	0.040	0.63	1.01
U	0.020	---	0.51	---
V	0.035	0.050	0.89	1.27
Z	0.155	0.170	3.93	4.32

RECOMMENDED
SOLDERING FOOTPRINT*

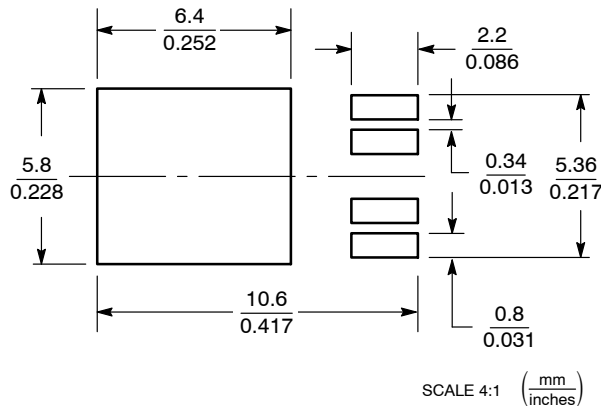

GENERIC
MARKING DIAGRAMS*

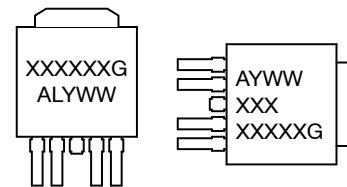

- XXXXXX = Device Code
A = Assembly Location
L = Wafer Lot
Y = Year
WW = Work Week
G = Pb-Free Package

*For additional information on our Pb-Free strategy and soldering details, please download the onsemi Soldering and Mounting Techniques Reference Manual, [SOLDERRM/D](#).

*This information is generic. Please refer to device data sheet for actual part marking. Pb-Free indicator, "G" or microdot "▪", may or may not be present.

DOCUMENT NUMBER:	98AON12855D	Electronic versions are uncontrolled except when accessed directly from the Document Repository. Printed versions are uncontrolled except when stamped "CONTROLLED COPY" in red.
DESCRIPTION:	DPAK-5 CENTER LEAD CROP	PAGE 1 OF 1

onsemi and ONSEMI are trademarks of Semiconductor Components Industries, LLC dba onsemi or its subsidiaries in the United States and/or other countries. onsemi reserves the right to make changes without further notice to any products herein. onsemi makes no warranty, representation or guarantee regarding the suitability of its products for any particular purpose, nor does onsemi assume any liability arising out of the application or use of any product or circuit, and specifically disclaims any and all liability, including without limitation special, consequential or incidental damages. onsemi does not convey any license under its patent rights nor the rights of others.

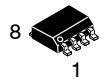

SCALE 1:1

SOIC-8 NB
CASE 751-07
ISSUE AK

DATE 16 FEB 2011

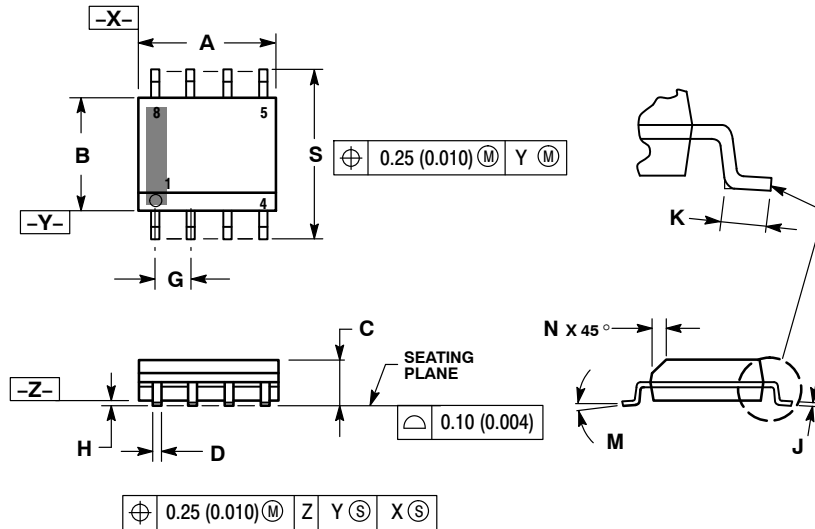

- NOTES:
1. DIMENSIONING AND TOLERANCING PER ANSI Y14.5M, 1982.
 2. CONTROLLING DIMENSION: MILLIMETER.
 3. DIMENSION A AND B DO NOT INCLUDE MOLD PROTRUSION.
 4. MAXIMUM MOLD PROTRUSION 0.15 (0.006) PER SIDE.
 5. DIMENSION D DOES NOT INCLUDE DAMBAR PROTRUSION. ALLOWABLE DAMBAR PROTRUSION SHALL BE 0.127 (0.005) TOTAL IN EXCESS OF THE D DIMENSION AT MAXIMUM MATERIAL CONDITION.
 6. 751-01 THRU 751-06 ARE OBSOLETE. NEW STANDARD IS 751-07.

DIM	MILLIMETERS		INCHES	
	MIN	MAX	MIN	MAX
A	4.80	5.00	0.189	0.197
B	3.80	4.00	0.150	0.157
C	1.35	1.75	0.053	0.069
D	0.33	0.51	0.013	0.020
G	1.27 BSC		0.050 BSC	
H	0.10	0.25	0.004	0.010
J	0.19	0.25	0.007	0.010
K	0.40	1.27	0.016	0.050
M	0°	8°	0°	8°
N	0.25	0.50	0.010	0.020
S	5.80	6.20	0.228	0.244

SOLDERING FOOTPRINT*

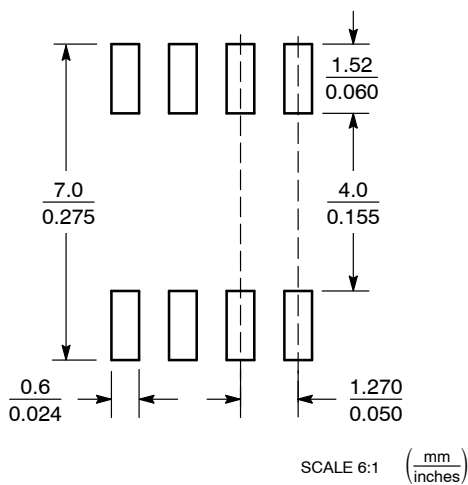

*For additional information on our Pb-Free strategy and soldering details, please download the onsemi Soldering and Mounting Techniques Reference Manual, SOLDERRM/D.

GENERIC MARKING DIAGRAM*



XXXXXX = Specific Device Code
A = Assembly Location
L = Wafer Lot
Y = Year
W = Work Week
▪ = Pb-Free Package

XXXXXX = Specific Device Code
A = Assembly Location
Y = Year
WW = Work Week
▪ = Pb-Free Package

*This information is generic. Please refer to device data sheet for actual part marking. Pb-Free indicator, "G" or microdot "▪", may or may not be present. Some products may not follow the Generic Marking.

STYLES ON PAGE 2

DOCUMENT NUMBER:	98ASB42564B	Electronic versions are uncontrolled except when accessed directly from the Document Repository. Printed versions are uncontrolled except when stamped "CONTROLLED COPY" in red.
DESCRIPTION:	SOIC-8 NB	PAGE 1 OF 2

onsemi and onsemi are trademarks of Semiconductor Components Industries, LLC dba onsemi or its subsidiaries in the United States and/or other countries. onsemi reserves the right to make changes without further notice to any products herein. onsemi makes no warranty, representation or guarantee regarding the suitability of its products for any particular purpose, nor does onsemi assume any liability arising out of the application or use of any product or circuit, and specifically disclaims any and all liability, including without limitation special, consequential or incidental damages. onsemi does not convey any license under its patent rights nor the rights of others.

SOIC-8 NB
CASE 751-07
ISSUE AK

DATE 16 FEB 2011

- | | | | |
|---|--|--|--|
| <p>STYLE 1:
 PIN 1. EMITTER
 2. COLLECTOR
 3. COLLECTOR
 4. EMITTER
 5. EMITTER
 6. BASE
 7. BASE
 8. EMITTER</p> | <p>STYLE 2:
 PIN 1. COLLECTOR, DIE, #1
 2. COLLECTOR, #1
 3. COLLECTOR, #2
 4. COLLECTOR, #2
 5. BASE, #2
 6. EMITTER, #2
 7. BASE, #1
 8. EMITTER, #1</p> | <p>STYLE 3:
 PIN 1. DRAIN, DIE #1
 2. DRAIN, #1
 3. DRAIN, #2
 4. DRAIN, #2
 5. GATE, #2
 6. SOURCE, #2
 7. GATE, #1
 8. SOURCE, #1</p> | <p>STYLE 4:
 PIN 1. ANODE
 2. ANODE
 3. ANODE
 4. ANODE
 5. ANODE
 6. ANODE
 7. ANODE
 8. COMMON CATHODE</p> |
| <p>STYLE 5:
 PIN 1. DRAIN
 2. DRAIN
 3. DRAIN
 4. DRAIN
 5. GATE
 6. GATE
 7. SOURCE
 8. SOURCE</p> | <p>STYLE 6:
 PIN 1. SOURCE
 2. DRAIN
 3. DRAIN
 4. SOURCE
 5. SOURCE
 6. GATE
 7. GATE
 8. SOURCE</p> | <p>STYLE 7:
 PIN 1. INPUT
 2. EXTERNAL BYPASS
 3. THIRD STAGE SOURCE
 4. GROUND
 5. DRAIN
 6. GATE 3
 7. SECOND STAGE Vd
 8. FIRST STAGE Vd</p> | <p>STYLE 8:
 PIN 1. COLLECTOR, DIE #1
 2. BASE, #1
 3. BASE, #2
 4. COLLECTOR, #2
 5. COLLECTOR, #2
 6. EMITTER, #2
 7. EMITTER, #1
 8. COLLECTOR, #1</p> |
| <p>STYLE 9:
 PIN 1. EMITTER, COMMON
 2. COLLECTOR, DIE #1
 3. COLLECTOR, DIE #2
 4. EMITTER, COMMON
 5. EMITTER, COMMON
 6. BASE, DIE #2
 7. BASE, DIE #1
 8. EMITTER, COMMON</p> | <p>STYLE 10:
 PIN 1. GROUND
 2. BIAS 1
 3. OUTPUT
 4. GROUND
 5. GROUND
 6. BIAS 2
 7. INPUT
 8. GROUND</p> | <p>STYLE 11:
 PIN 1. SOURCE 1
 2. GATE 1
 3. SOURCE 2
 4. GATE 2
 5. DRAIN 2
 6. DRAIN 2
 7. DRAIN 1
 8. DRAIN 1</p> | <p>STYLE 12:
 PIN 1. SOURCE
 2. SOURCE
 3. SOURCE
 4. GATE
 5. DRAIN
 6. DRAIN
 7. DRAIN
 8. DRAIN</p> |
| <p>STYLE 13:
 PIN 1. N.C.
 2. SOURCE
 3. SOURCE
 4. GATE
 5. DRAIN
 6. DRAIN
 7. DRAIN
 8. DRAIN</p> | <p>STYLE 14:
 PIN 1. N-SOURCE
 2. N-GATE
 3. P-SOURCE
 4. P-GATE
 5. P-DRAIN
 6. P-DRAIN
 7. N-DRAIN
 8. N-DRAIN</p> | <p>STYLE 15:
 PIN 1. ANODE 1
 2. ANODE 1
 3. ANODE 1
 4. ANODE 1
 5. CATHODE, COMMON
 6. CATHODE, COMMON
 7. CATHODE, COMMON
 8. CATHODE, COMMON</p> | <p>STYLE 16:
 PIN 1. EMITTER, DIE #1
 2. BASE, DIE #1
 3. EMITTER, DIE #2
 4. BASE, DIE #2
 5. COLLECTOR, DIE #2
 6. COLLECTOR, DIE #2
 7. COLLECTOR, DIE #1
 8. COLLECTOR, DIE #1</p> |
| <p>STYLE 17:
 PIN 1. VCC
 2. V2OUT
 3. V1OUT
 4. TXE
 5. RXE
 6. VEE
 7. GND
 8. ACC</p> | <p>STYLE 18:
 PIN 1. ANODE
 2. ANODE
 3. SOURCE
 4. GATE
 5. DRAIN
 6. DRAIN
 7. CATHODE
 8. CATHODE</p> | <p>STYLE 19:
 PIN 1. SOURCE 1
 2. GATE 1
 3. SOURCE 2
 4. GATE 2
 5. DRAIN 2
 6. MIRROR 2
 7. DRAIN 1
 8. MIRROR 1</p> | <p>STYLE 20:
 PIN 1. SOURCE (N)
 2. GATE (N)
 3. SOURCE (P)
 4. GATE (P)
 5. DRAIN
 6. DRAIN
 7. DRAIN
 8. DRAIN</p> |
| <p>STYLE 21:
 PIN 1. CATHODE 1
 2. CATHODE 2
 3. CATHODE 3
 4. CATHODE 4
 5. CATHODE 5
 6. COMMON ANODE
 7. COMMON ANODE
 8. CATHODE 6</p> | <p>STYLE 22:
 PIN 1. I/O LINE 1
 2. COMMON CATHODE/VCC
 3. COMMON CATHODE/VCC
 4. I/O LINE 3
 5. COMMON ANODE/GND
 6. I/O LINE 4
 7. I/O LINE 5
 8. COMMON ANODE/GND</p> | <p>STYLE 23:
 PIN 1. LINE 1 IN
 2. COMMON ANODE/GND
 3. COMMON ANODE/GND
 4. LINE 2 IN
 5. LINE 2 OUT
 6. COMMON ANODE/GND
 7. COMMON ANODE/GND
 8. LINE 1 OUT</p> | <p>STYLE 24:
 PIN 1. BASE
 2. EMITTER
 3. COLLECTOR/ANODE
 4. COLLECTOR/ANODE
 5. CATHODE
 6. CATHODE
 7. COLLECTOR/ANODE
 8. COLLECTOR/ANODE</p> |
| <p>STYLE 25:
 PIN 1. VIN
 2. N/C
 3. REXT
 4. GND
 5. IOUT
 6. IOUT
 7. IOUT
 8. IOUT</p> | <p>STYLE 26:
 PIN 1. GND
 2. dv/dt
 3. ENABLE
 4. ILIMIT
 5. SOURCE
 6. SOURCE
 7. SOURCE
 8. VCC</p> | <p>STYLE 27:
 PIN 1. ILIMIT
 2. OVLO
 3. UVLO
 4. INPUT+
 5. SOURCE
 6. SOURCE
 7. SOURCE
 8. DRAIN</p> | <p>STYLE 28:
 PIN 1. SW_TO_GND
 2. DASIC OFF
 3. DASIC_SW_DET
 4. GND
 5. V_MON
 6. VBULK
 7. VBULK
 8. VIN</p> |
| <p>STYLE 29:
 PIN 1. BASE, DIE #1
 2. EMITTER, #1
 3. BASE, #2
 4. EMITTER, #2
 5. COLLECTOR, #2
 6. COLLECTOR, #2
 7. COLLECTOR, #1
 8. COLLECTOR, #1</p> | <p>STYLE 30:
 PIN 1. DRAIN 1
 2. DRAIN 1
 3. GATE 2
 4. SOURCE 2
 5. SOURCE 1/DRAIN 2
 6. SOURCE 1/DRAIN 2
 7. SOURCE 1/DRAIN 2
 8. GATE 1</p> | | |

DOCUMENT NUMBER:	98ASB42564B	Electronic versions are uncontrolled except when accessed directly from the Document Repository. Printed versions are uncontrolled except when stamped "CONTROLLED COPY" in red.
DESCRIPTION:	SOIC-8 NB	PAGE 2 OF 2

onsemi and **ONSEMI** are trademarks of Semiconductor Components Industries, LLC dba **onsemi** or its subsidiaries in the United States and/or other countries. **onsemi** reserves the right to make changes without further notice to any products herein. **onsemi** makes no warranty, representation or guarantee regarding the suitability of its products for any particular purpose, nor does **onsemi** assume any liability arising out of the application or use of any product or circuit, and specifically disclaims any and all liability, including without limitation special, consequential or incidental damages. **onsemi** does not convey any license under its patent rights nor the rights of others.

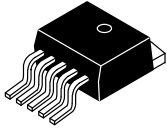

SCALE 1:1

D²PAK-5 8.89x10.20x0.12, 1.70P
CASE 936AC
ISSUE B

DATE 27 APR 2026

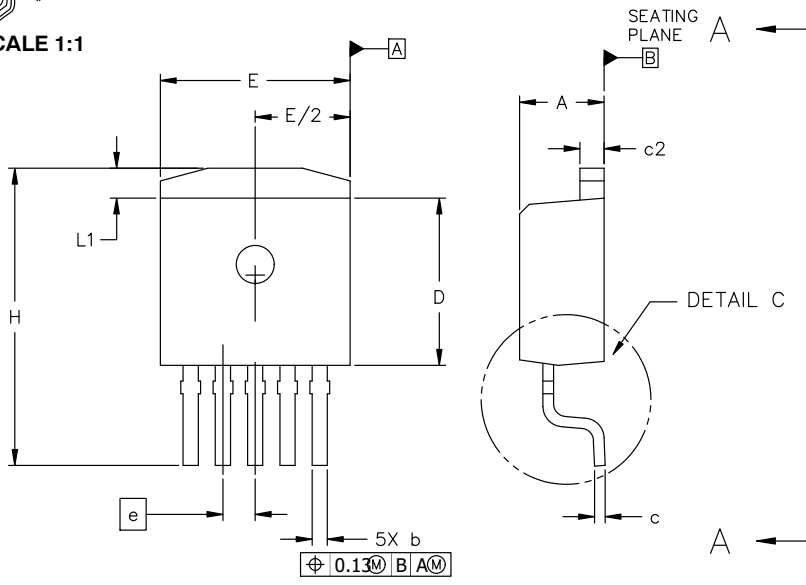

MILLIMETERS			
DIM	MIN	NOM	MAX
A	4.320	4.445	4.570
A1	0.000	0.125	0.250
b	0.660	0.785	0.910
c	0.430	0.545	0.660
c2	1.140	1.270	1.400
D	8.250	8.890	9.530
D1	6.350	---	---
E	9.650	10.205	10.760
E1	5.080	---	---
e	1.700 BSC		
H	14.730	15.240	15.750
L	2.290	2.540	2.790
L1	---	---	1.680
L3	0.250 BSC		
M	0°	4°	8°

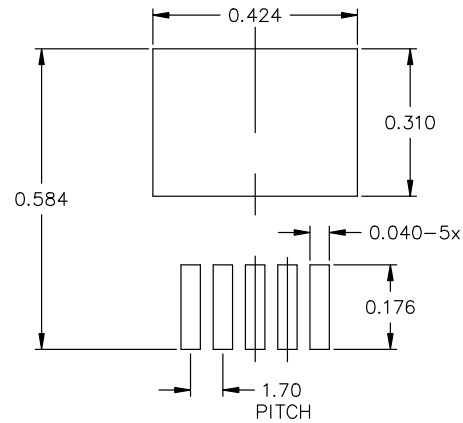
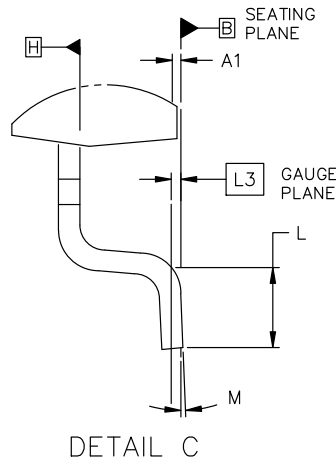
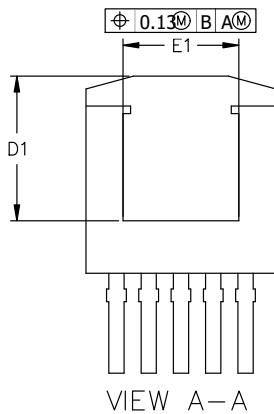

NOTES:

- CONTROLLING DIMENSION: MILLIMETERS [mm].
- ENCAPSULANT: EPOXY.
- DIMENSIONS D AND E DO NOT INCLUDE MOLD FLASH OR GATE PROTRUSIONS. MOLD FLASH AND GATE PROTRUSIONS NOT TO EXCEED 0.005 MAXIMUM PER SIDE. THESE DIMENSIONS TO BE MEASURED AT DATUM H.
- THERMAL PAD CONTOUR OPTIONAL WITHIN DIMENSIONS E, L1, D1, AND E1. DIMENSIONS D1 AND E1 ESTABLISH A MINIMUM MOUNTING SURFACE FOR THE THERMAL PAD.

RECOMMENDED MOUNTING FOOTPRINT

*For additional information on our Pb-Free strategy and soldering details, please download the onsemi Soldering and Mounting Techniques Reference Manual, SOLDERRM/D.

GENERIC MARKING DIAGRAM*

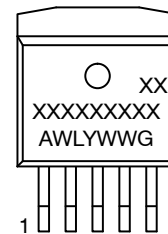

- XXXXXX = Specific Device Code
- A = Assembly Location
- WL = Wafer Lot
- Y = Year
- WW = Work Week
- G = Pb-Free Package

*This information is generic. Please refer to device data sheet for actual part marking. Pb-Free indicator, "G" or microdot "•", may or may not be present. Some products may not follow the Generic Marking.

DOCUMENT NUMBER:	98AON14120D	Electronic versions are uncontrolled except when accessed directly from the Document Repository. Printed versions are uncontrolled except when stamped "CONTROLLED COPY" in red.
DESCRIPTION:	D ² PAK-5 8.89x10.20x0.12, 1.70P	PAGE 1 OF 1

onsemi and ONSEMI are trademarks of Semiconductor Components Industries, LLC dba onsemi or its subsidiaries in the United States and/or other countries. onsemi reserves the right to make changes without further notice to any products herein. onsemi makes no warranty, representation or guarantee regarding the suitability of its products for any particular purpose, nor does onsemi assume any liability arising out of the application or use of any product or circuit, and specifically disclaims any and all liability, including without limitation special, consequential or incidental damages. onsemi does not convey any license under its patent rights nor the rights of others.

onsemi, **Onsemi**, and other names, marks, and brands are registered and/or common law trademarks of Semiconductor Components Industries, LLC dba "**onsemi**" or its affiliates and/or subsidiaries in the United States and/or other countries. **onsemi** owns the rights to a number of patents, trademarks, copyrights, trade secrets, and other intellectual property. A listing of **onsemi**'s product/patent coverage may be accessed at www.onsemi.com/site/pdf/Patent-Marking.pdf. **onsemi** reserves the right to make changes at any time to any products or information herein, without notice. The information herein is provided "as-is" and **onsemi** makes no warranty, representation or guarantee regarding the accuracy of the information, product features, availability, functionality, or suitability of its products for any particular purpose, nor does **onsemi** assume any liability arising out of the application or use of any product or circuit, and specifically disclaims any and all liability, including without limitation special, consequential or incidental damages. Buyer is responsible for its products and applications using **onsemi** products, including compliance with all laws, regulations and safety requirements or standards, regardless of any support or applications information provided by **onsemi**. "Typical" parameters which may be provided in **onsemi** data sheets and/or specifications can and do vary in different applications and actual performance may vary over time. All operating parameters, including "Typicals" must be validated for each customer application by customer's technical experts. **onsemi** does not convey any license under any of its intellectual property rights nor the rights of others. **onsemi** products are not designed, intended, or authorized for use as a critical component in life support systems or any FDA Class 3 medical devices or medical devices with a same or similar classification in a foreign jurisdiction or any devices intended for implantation in the human body. Should Buyer purchase or use **onsemi** products for any such unintended or unauthorized application, Buyer shall indemnify and hold **onsemi** and its officers, employees, subsidiaries, affiliates, and distributors harmless against all claims, costs, damages, and expenses, and reasonable attorney fees arising out of, directly or indirectly, any claim of personal injury or death associated with such unintended or unauthorized use, even if such claim alleges that **onsemi** was negligent regarding the design or manufacture of the part. **onsemi** is an Equal Opportunity/Affirmative Action Employer. This literature is subject to all applicable copyright laws and is not for resale in any manner.

ADDITIONAL INFORMATION

TECHNICAL PUBLICATIONS:

Technical Library: www.onsemi.com/design/resources/technical-documentation
onsemi Website: www.onsemi.com

ONLINE SUPPORT: www.onsemi.com/support

For additional information, please contact your local Sales Representative at www.onsemi.com/support/sales