

# High Voltage Switching Diodes

## BASH16MX2W

The BASH16MX2W Switching Diode is a spin-off of our popular SOT-23 three-leaded device. It is designed for switching applications and is housed in the X2DFNW2 (1.0x0.6 mm) surface mount package. This device is ideal for low-power surface mount applications, where board space is at a premium.

### Features

- 175 °C  $T_{J(max)}$ -Rated for High Temperature, Mission Critical Applications
- Wetable Flank Package for optimal Automated Optical Inspection (AOI)
- NSV Prefix for Automotive and Other Applications Requiring Unique Site and Control Change Requirements; AEC-Q101 Qualified and PPAP Capable
- These Devices are Pb-Free, Halogen Free/BFR Free and are RoHS Compliant

### MAXIMUM RATINGS

Rating	Symbol	Value	Unit
Continuous Reverse Voltage BASH16 BASH19 BASH20 BASH21	$V_R$ , $V_{RRM}$	100 120 200 250	Vdc
Continuous Forward Current	$I_F$	200	mAdc
Repetitive Peak Forward Current (Pulse Wave = 1 sec, Duty Cycle = 66%)	$I_{FRM}$	500	mA
Non-Repetitive Peak Forward Current (Square Wave, $T_J = 25\text{ °C}$ prior to surge) BASH16 $t = 1\ \mu\text{s}$ $t = 1\ \text{ms}$ $t = 1\ \text{s}$ BASH19/20/21 $t = 1\ \mu\text{s}$ $t = 1\ \text{ms}$ $t = 1\ \text{s}$	$I_{FSM}$	5.0 2.0 0.5 9.0 3.0 1.7	A

### THERMAL CHARACTERISTICS

Characteristic	Symbol	Max	Unit
Total Device Dissipation FR-5 Board $T_A = 25\text{ °C}$ (Note 1)	$P_D$	300	mW
Thermal Resistance Junction-to-Ambient (Note 1)	$R_{\theta JA}$	400	°C/W
Thermal Resistance Junction-to-Solder Point (Note 1)	$R_{\theta JSP}$	105	°C/W
Junction and Storage Temperature Range	$T_J, T_{stg}$	-55 to +175	°C

Stresses exceeding those listed in the Maximum Ratings table may damage the device. If any of these limits are exceeded, device functionality should not be assumed, damage may occur and reliability may be affected.

1. Mounted onto a 4 in square FR-4 board 10 mm sq. 1 oz. Cu 0.06" thick single sided. Operating to steady state.

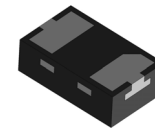
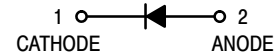

X2DFNW2  
CASE 711BG

### MARKING DIAGRAM



XX = Specific Device Code  
M = Date Code

### ORDERING INFORMATION

See detailed ordering, marking and shipping information on page 4 of this data sheet.

# BASH16MX2W

## ELECTRICAL CHARACTERISTICS ( $T_A = 25\text{ }^\circ\text{C}$ unless otherwise noted)

Characteristic	Symbol	Min	Max	Unit
<b>OFF CHARACTERISTICS</b>				
Reverse Voltage Leakage Current ( $V_R = 80\text{ Vdc}$ ) ( $V_R = 100\text{ Vdc}$ ) ( $V_R = 150\text{ Vdc}$ ) ( $V_R = 200\text{ Vdc}$ ) ( $V_R = 80\text{ Vdc}$ , $T_J = 150\text{ }^\circ\text{C}$ ) ( $V_R = 25\text{ Vdc}$ , $T_J = 150\text{ }^\circ\text{C}$ ) ( $V_R = 100\text{ Vdc}$ , $T_J = 150\text{ }^\circ\text{C}$ ) ( $V_R = 150\text{ Vdc}$ , $T_J = 150\text{ }^\circ\text{C}$ ) ( $V_R = 200\text{ Vdc}$ , $T_J = 150\text{ }^\circ\text{C}$ )	BASH16 BASH19 BASH20 BASH21 BASH16 BASH16 BASH19 BASH20 BASH21	$I_R$	- - - - - - - - -	0.5 0.1 0.1 0.1 50 30 100 100 100 $\mu\text{A}$
Reverse Breakdown Voltage ( $I_{BR} = 100\text{ }\mu\text{A}$ )	BASH16 BASH19 BASH20 BASH21	$V_{(BR)}$	100 120 200 250	- - - - Vdc
Forward Voltage ( $I_F = 100\text{ mA}$ ) ( $I_F = 200\text{ mA}$ )		$V_F$	- -	1.0 1.25 Vdc
Diode Capacitance ( $V_R = 0$ , $f = 1.0\text{ MHz}$ )		$C_D$	-	3.0 pF
Reverse Recovery Time ( $I_F = I_R = 10\text{ mA}$ , $R_L = 50\text{ }\Omega$ ) ( $I_F = I_R = 30\text{ mA}$ , $R_L = 100\text{ }\Omega$ )	BASH16 BASH19/20/21	$t_{rr}$	- -	6.0 50 ns

Product parametric performance is indicated in the Electrical Characteristics for the listed test conditions, unless otherwise noted. Product performance may not be indicated by the Electrical Characteristics if operated under different conditions.

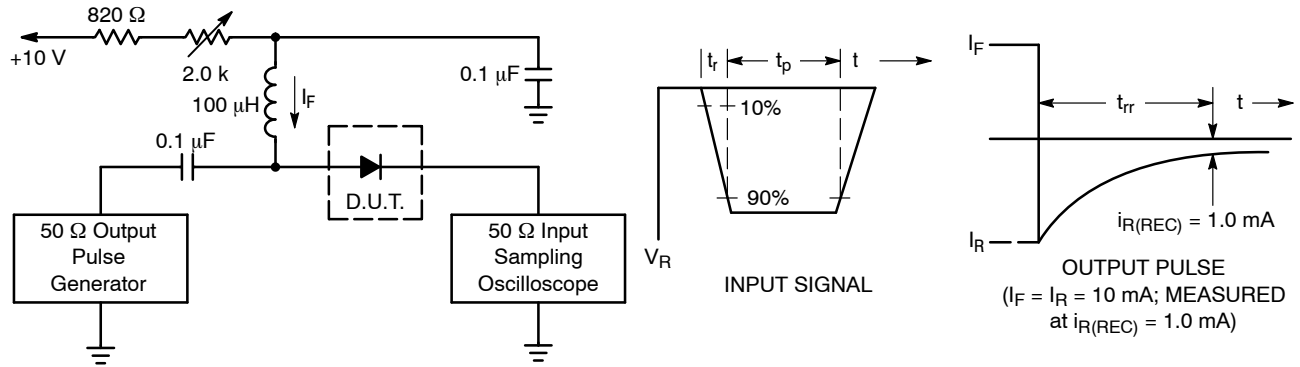

- Notes: 1. A 2.0 kΩ variable resistor adjusted for a Forward Current ( $I_F$ ) of 10 mA.  
 2. Input pulse is adjusted so  $I_{R(\text{peak})}$  is equal to 10 mA.  
 3.  $t_p > t_{rr}$

**Figure 1. Recovery Time Equivalent Test Circuit**

# BASH16MX2W

## TYPICAL CHARACTERISTICS

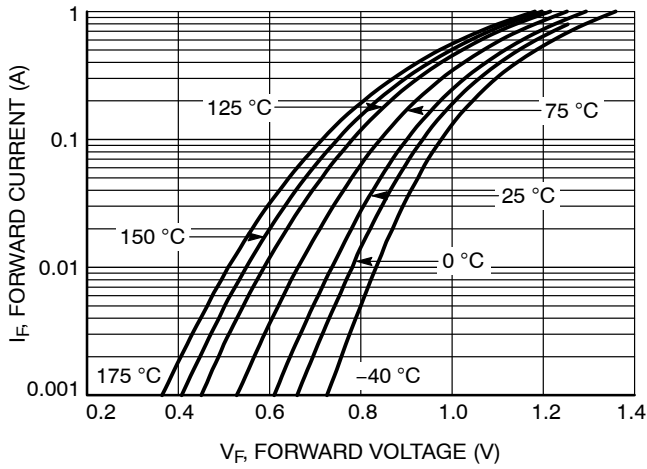

Figure 2. Forward Voltage

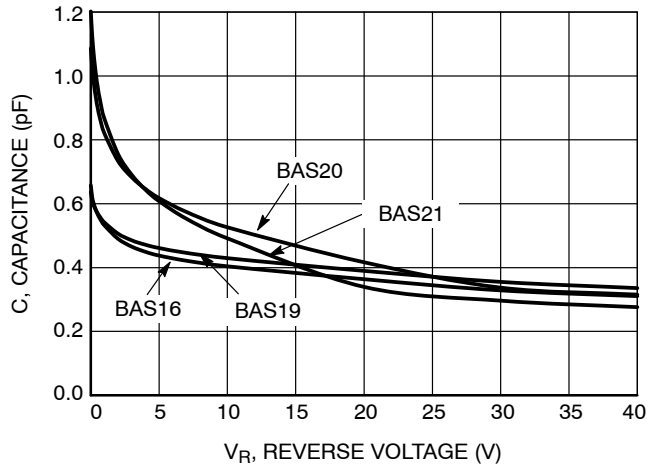

Figure 3. Total Capacitance

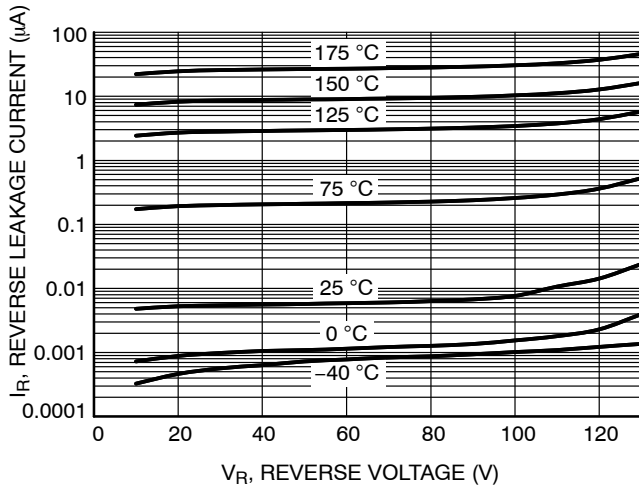

Figure 4. Reverse Current-BASH16

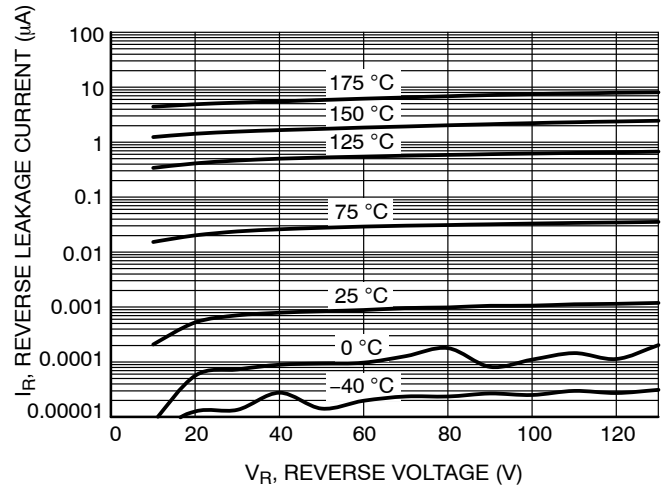

Figure 5. Reverse Current-BASH19

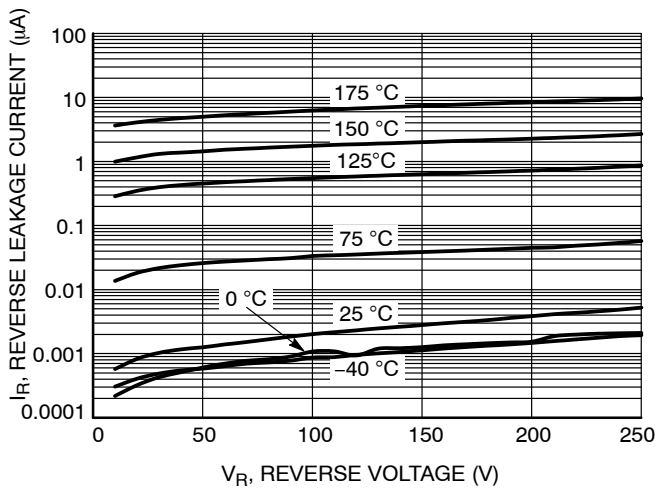

Figure 6. Reverse Current-BASH20

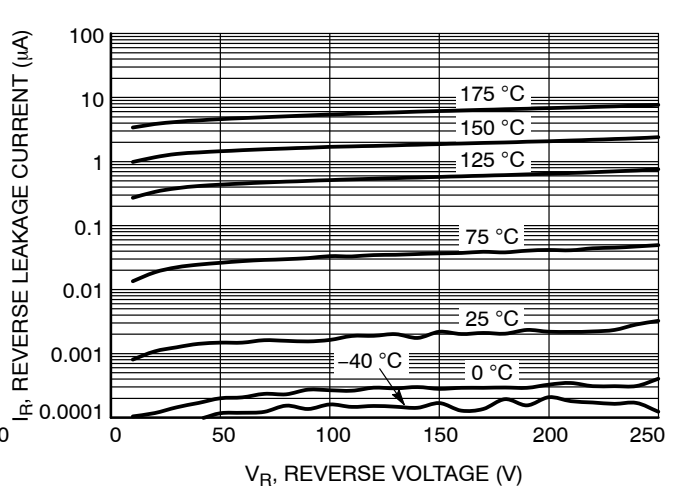

Figure 7. Reverse Current-BASH21

# BASH16MX2W

## DEVICE ORDERING INFORMATION

Device	Marking	Package	Shipping†
BASH16MX2WT5G, NSVBASH16MX2WT5G*	MF	X2DFN2 (Pb-Free)	8000 / Tape & Reel
BASH19MX2WT5G, NSVBASH19MX2WT5G*	MH		
BASH20MX2WT5G, NSVBASH20MX2WT5G*	MG		
BASH21MX2WT5G, NSVBASH21MX2WT5G*	ME		

† For information on tape and reel specifications, including part orientation and tape sizes, please refer to our Tape and Reel Packaging Specifications Brochure, [BRD8011/D](#).

\* NSV Prefix for Automotive and Other Applications Requiring Unique Site and Control Change Requirements; AEC-Q101 Qualified and PPAP Capable.

# BASH16MX2W

## REVISION HISTORY

Revision	Description of Changes	Date
4	Update of the front page case outline 3D model.	11/20/2025

This document has undergone updates prior to the inclusion of this revision history table. The changes tracked here only reflect updates made on the noted approval dates.

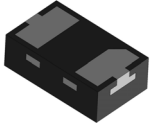

**X2DFNW-2 1.00x0.60x0.37, 0.65P**  
CASE 711BG  
ISSUE F

DATE 06 NOV 2025

NOTES:

1. DIMENSIONING AND TOLERANCING CONFORM TO ASME Y14.5-2018.
2. ALL DIMENSION ARE IN MILLIMETERS.
3. DIMENSION b APPLIES TO THE PLATED TERMINAL AND IS MEASURED BETWEEN 0.15 AND 0.30 FROM THE TERMINAL TIP.

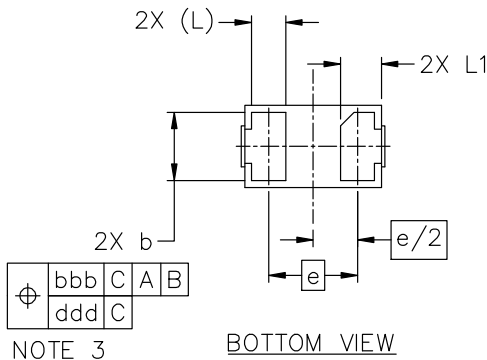
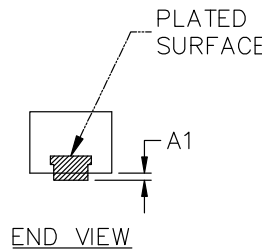
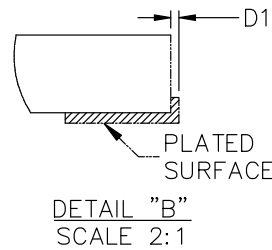
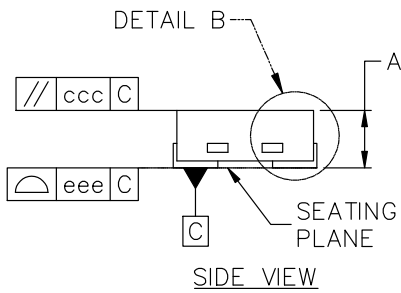
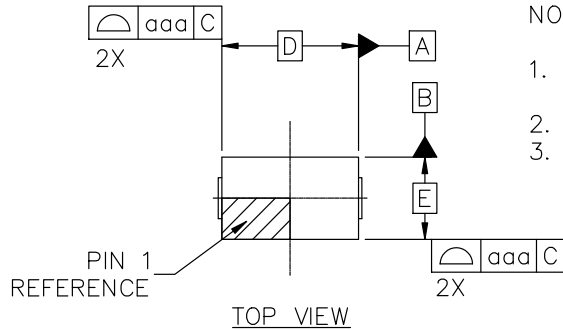

NOTE 3

**GENERIC MARKING DIAGRAM\***

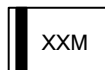

XX = Specific Device Code  
M = Date Code

\*This information is generic. Please refer to device data sheet for actual part marking. Pb-Free indicator, "G", may or not be present. Some products may not follow the Generic Marking.

MILLIMETERS			
DIM	MIN	NOM	MAX
A	0.34	0.37	0.40
A1	~	~	0.05
b	0.45	0.50	0.55
D	1.00 BSC		
D1	~	~	0.05
E	0.60 BSC		
e	0.65 BSC		
L	0.22 REF		
L1	0.24	0.28	0.34
TOLERANCE FORM & POSITION			
aaa	0.05		
bbb	0.10		
ccc	0.05		
ddd	0.05		
eee	0.05		

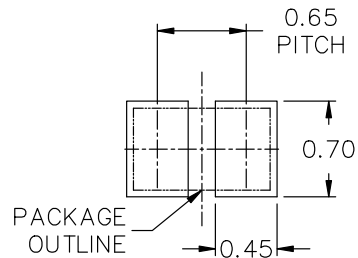

RECOMMENDED MOUNTING FOOTPRINT\*

\* FOR ADDITIONAL INFORMATION ON OUR Pb-FREE STRATEGY AND SOLDERING DETAILS, PLEASE DOWNLOAD THE onsemi SOLDERING AND MOUNTING TECHNIQUES REFERENCE MANUAL, SOLDERRM/D.

<b>DOCUMENT NUMBER:</b>	<b>98AON15241G</b>	Electronic versions are uncontrolled except when accessed directly from the Document Repository. Printed versions are uncontrolled except when stamped "CONTROLLED COPY" in red.
<b>DESCRIPTION:</b>	<b>X2DFNW-2 1.00x0.60x0.37, 0.65P</b>	<b>PAGE 1 OF 1</b>

onsemi and ONSEMI are trademarks of Semiconductor Components Industries, LLC dba onsemi or its subsidiaries in the United States and/or other countries. onsemi reserves the right to make changes without further notice to any products herein. onsemi makes no warranty, representation or guarantee regarding the suitability of its products for any particular purpose, nor does onsemi assume any liability arising out of the application or use of any product or circuit, and specifically disclaims any and all liability, including without limitation special, consequential or incidental damages. onsemi does not convey any license under its patent rights nor the rights of others.

**onsemi**, **Onsemi**, and other names, marks, and brands are registered and/or common law trademarks of Semiconductor Components Industries, LLC dba "**onsemi**" or its affiliates and/or subsidiaries in the United States and/or other countries. **onsemi** owns the rights to a number of patents, trademarks, copyrights, trade secrets, and other intellectual property. A listing of **onsemi**'s product/patent coverage may be accessed at [www.onsemi.com/site/pdf/Patent-Marking.pdf](http://www.onsemi.com/site/pdf/Patent-Marking.pdf). **onsemi** reserves the right to make changes at any time to any products or information herein, without notice. The information herein is provided "as-is" and **onsemi** makes no warranty, representation or guarantee regarding the accuracy of the information, product features, availability, functionality, or suitability of its products for any particular purpose, nor does **onsemi** assume any liability arising out of the application or use of any product or circuit, and specifically disclaims any and all liability, including without limitation special, consequential or incidental damages. Buyer is responsible for its products and applications using **onsemi** products, including compliance with all laws, regulations and safety requirements or standards, regardless of any support or applications information provided by **onsemi**. "Typical" parameters which may be provided in **onsemi** data sheets and/or specifications can and do vary in different applications and actual performance may vary over time. All operating parameters, including "Typicals" must be validated for each customer application by customer's technical experts. **onsemi** does not convey any license under any of its intellectual property rights nor the rights of others. **onsemi** products are not designed, intended, or authorized for use as a critical component in life support systems or any FDA Class 3 medical devices or medical devices with a same or similar classification in a foreign jurisdiction or any devices intended for implantation in the human body. Should Buyer purchase or use **onsemi** products for any such unintended or unauthorized application, Buyer shall indemnify and hold **onsemi** and its officers, employees, subsidiaries, affiliates, and distributors harmless against all claims, costs, damages, and expenses, and reasonable attorney fees arising out of, directly or indirectly, any claim of personal injury or death associated with such unintended or unauthorized use, even if such claim alleges that **onsemi** was negligent regarding the design or manufacture of the part. **onsemi** is an Equal Opportunity/Affirmative Action Employer. This literature is subject to all applicable copyright laws and is not for resale in any manner.

## ADDITIONAL INFORMATION

### TECHNICAL PUBLICATIONS:

Technical Library: [www.onsemi.com/design/resources/technical-documentation](http://www.onsemi.com/design/resources/technical-documentation)  
onsemi Website: [www.onsemi.com](http://www.onsemi.com)

### ONLINE SUPPORT: [www.onsemi.com/support](http://www.onsemi.com/support)

For additional information, please contact your local Sales Representative at [www.onsemi.com/support/sales](http://www.onsemi.com/support/sales)