

Comparing onsemi Pixel Controllers for use in Advanced Lighting Architectures

AND90309/D

INTRODUCTION:

Pixel Controllers are an integral part of modern automotive lighting systems, enabling advanced functionality that significantly enhances both driving control and safety. Their ability to control individual light-emitting diodes (LEDs) allows designers and manufacturers to define headlamps with eye catching animations as part of the vehicle light signature.

Key applications include:

- Dynamic Turn Indicators
 - ◆ Create dynamic lighting effects that can improve signal perception and reaction time of other road users

PIXEL CONTROLLERS

In modern automotive headlamps, LEDs are often connected in series, with the total string voltage reaching up to 60 V. A high-power LED driver provides current to the entire LED string. To control individual LEDs within the string, switches are connected in parallel to each LED. These switches are typically embedded within a Pixel Controller, a device that receives data from the Electronic Control Unit (ECU) and applies the required PWM dimming to each pixel, creating the desired light pattern. Additionally, Pixel Controller can also detect various fault conditions (open LED, shorted LED etc.) and report diagnostic information back to the ECU.

NCV78247 Pixel Controller – 1st Generation

The NCV78247 is a single-chip pixel controller designed to manage high-current LEDs in a series LED string. It features embedded switches that can control up to 12 pixels, each with a maximum switch current of up to 1 A. For applications requiring higher LED currents, these switches can be parallelized.

Device utilizes SPI interface to communicate with MCU, which makes it especially suitable for applications where Pixel Controllers are integrated inside Led Driver Module (LDM). Dedicated synchronization pin allows to connect multiple devices to the same LED string in case more than 12 pixels are required.

- Glare-Free High Beam Headlamps
 - ◆ Maintain maximum road illumination thanks to automatic adjustment of high beam pattern to avoid blinding oncoming traffic
- Pedestrian and Traffic Sign Highlighting
 - ◆ Enhance visibility of pedestrians and traffic signs by selectively illuminating them

This document describes different headlamp architectures and suggests suitable products from **onsemi** portfolio.

NCV78343 Pixel Controller – 2nd Generation

The NCV78343 offers several enhancements over the NCV78247, including lower switch resistance, a higher maximum switch current of 1.4 A, and an ASIL-B safety rating with fail-safe settings defined in one-time programmable memory.

To provide versatility, the NCV78343 offers two communication interfaces for connection with the MCU. UART interface supports use of CAN transceiver for long distance communication. Multipoint low voltage differential signaling interface (M-LVDS) can also be used for either local connection or connection between multiple PCBs. Both interfaces support up to 32 connected devices with speeds up to 1 MBit. There is an integrated bridge functionality between UART and M-LVDS interface to maximize interconnection possibilities.

For applications without a local MCU, the NCV78343 meets specific requirements with three ADC inputs. These inputs can be used to read LED temperature via a thermistor, report the value of a binning resistor, or decode an addressing resistor. Its I2C interface can be connected to external EEPROM from which customer data (headlamp identification code, LED binning, customer specific data etc.) can be read and stored.

LED HEADLAMP ARCHITECTURES

LED Driver Module (LDM)

A LED Driver Module main task is to provide constant current to light-emitting diodes. Common LDMs include MCU-controlled LED drivers that can adjust power supplied to LEDs as well as provide protection and

diagnostics. LDM is usually equipped with a cooler to dissipate heat created by power losses during DC/DC power conversion. Higher-end LDMs support use of Pixel Controllers. Basic block diagram of LDM is depicted in Figure 1.

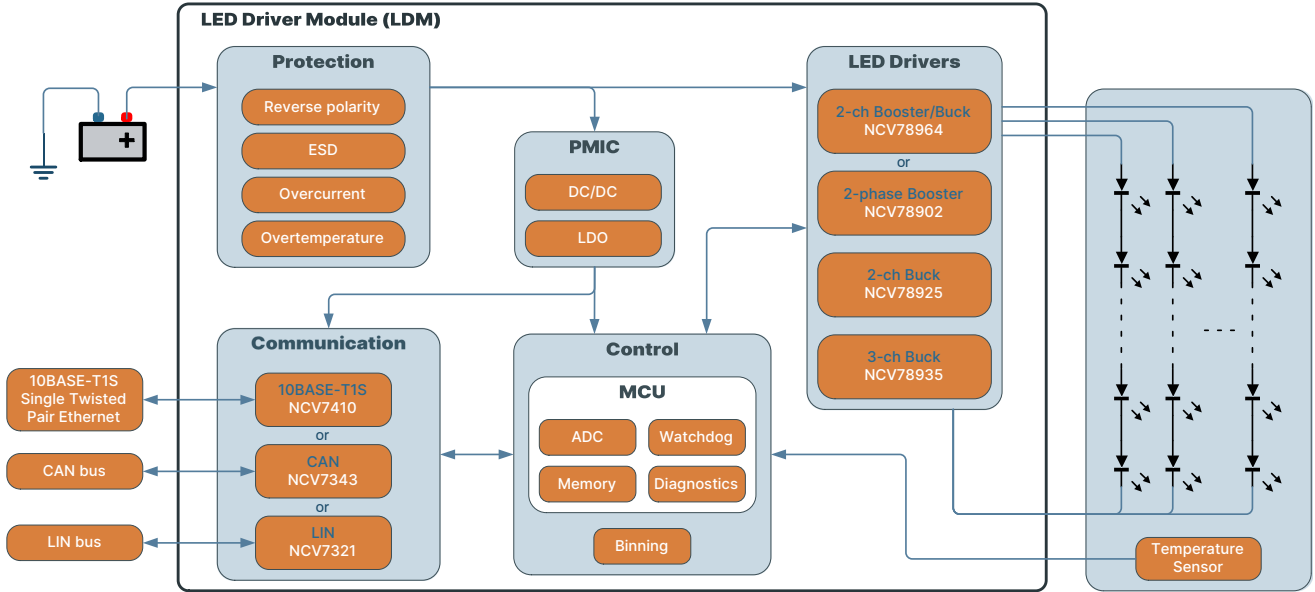

Figure 1. LED Driver Module (LDM) Block Diagram

Architecture Example 1 – Application with Local MCU

Figure 2 and Figure 3 represent typical architectures with local microcontroller. Figure 2 depicts solution with Pixel Controllers included in LED Driver Module itself.

The advantage of this architecture is that PCBs with light-emitting diodes can remain simple, small and cost effective.

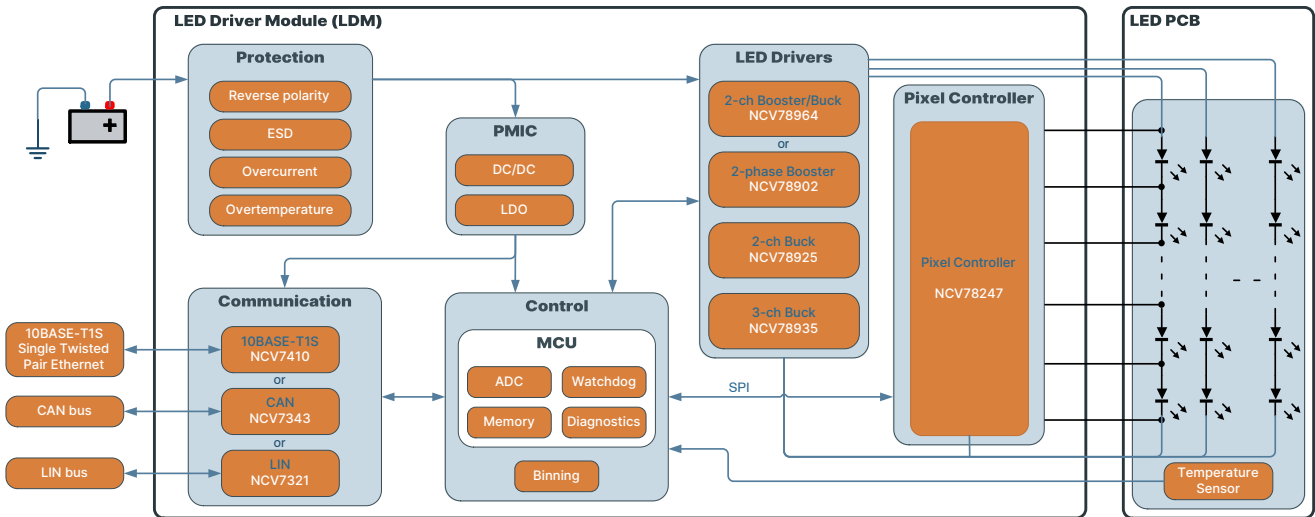

Figure 2. Pixel Controller Embedded in LDM with Local MCU

Main drawback of this solution is the large number of wires going between the LDM and LED PCB. Depending on the state of Pixel Controller switches, LED string current is either going through LED string, or through these wires into

embedded switches. During dimming operation, the state of switches changes constantly. This must be considered during design to avoid EMC issues.

A more commonly found architecture is shown in Figure 3. Here, the Pixel Controller device is placed directly on the same PCB as the LEDs, eliminating the need for long

cables between the embedded switches and the LEDs, thereby improving EMC performance.

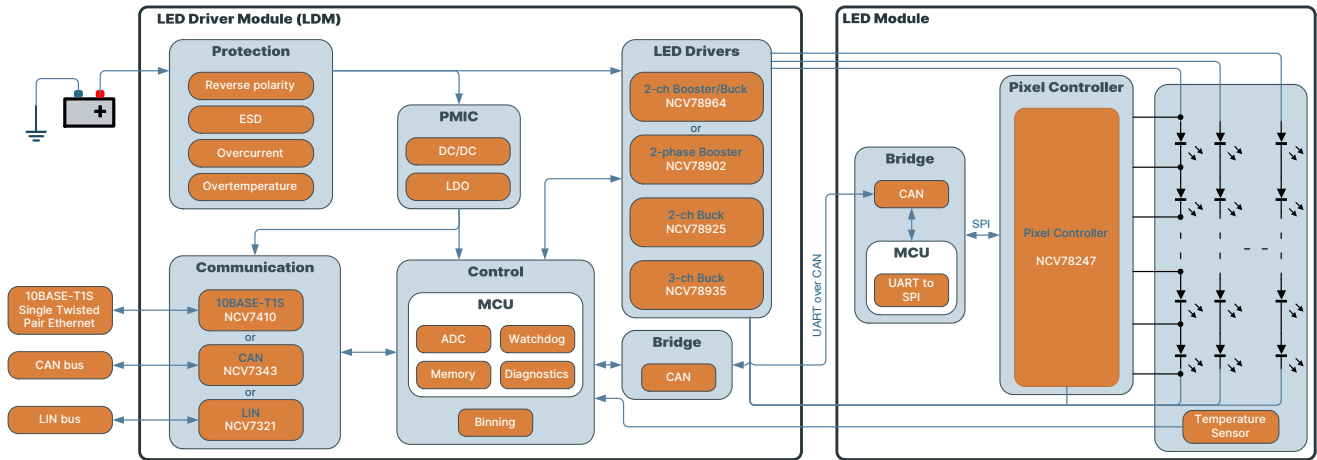

Figure 3. Pixel Controller in LED Module Connected over Communication Bridge Device

The NCV78247 is a cost-effective choice in both variants due to its lack of internal ADC converters and other features that can be managed by the local MCU. Figure 3 shows a block diagram with the NCV78247 device in use. Because of the distance between MCU and NCV78247 device, communication must go over a bridge device using automotive qualified high-speed bus to facilitate communication between ECU and Pixel Controllers. This bridge device can be a simple MCU translating SPI commands into UART over CAN type of communication. Other SPI-controlled devices, such as stepper drivers located on a different PCB, can also be controlled via the same bridge.

Architecture Example 2 - Application without Local MCU

The standard architecture in current automotive headlamps is depicted in Figure 4. The absence of a local MCU means that there is generally no MCU placed on the same PCB as the Pixel Controller. Reducing the number of required microcontrollers brings several benefits, including cost savings, reduced PCB footprint, increased flexibility, and easier software management. However, MCUs are typically used for temperature monitoring and binning via their ADC inputs, or for customer data storage inside their memory. These features must be integrated into the Pixel Controller device to fully replace the local MCU.

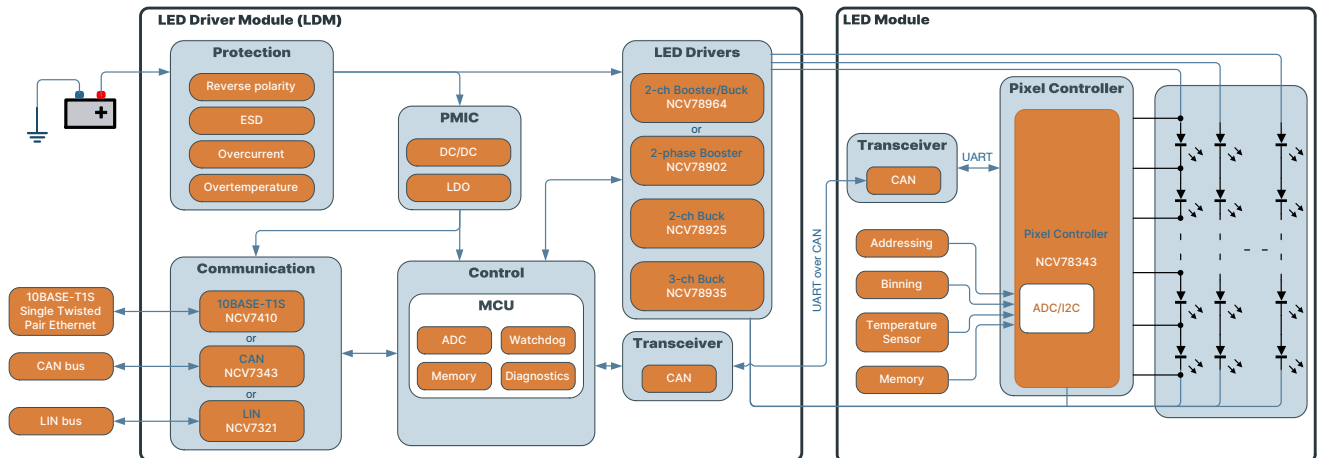

Figure 4. Standard Architecture with Pixel Controller Inside LED Module

In this architecture, Pixel Controllers are usually placed on the same PCB as the light-emitting diodes. The main advantages include reduced cabling and improved EMC

performance compared to applications where the Pixel Controller is located inside the LDM. Since power losses caused by the resistance of Pixel Controller switches are

minimal compared to the power losses of the light-emitting diodes, placing the Pixel Controller directly on a board shared with LEDs benefits from the common heatsink design. Nonetheless, the Pixel Controller pinout should be optimized for a single-layer PCB layout to support commonly used Metal Core (IMS) PCBs with enhanced thermal conductivity.

NCV78343 device is a perfect fit for this application. Its communication interfaces support long distance data transfer to facilitate connection to MCU. The integrated bridge between UART and M-LVDS can be utilized to connect multiple Pixel Controllers placed across several separated PCBs. An architecture example with NCV78343 is shown in Figure 5.

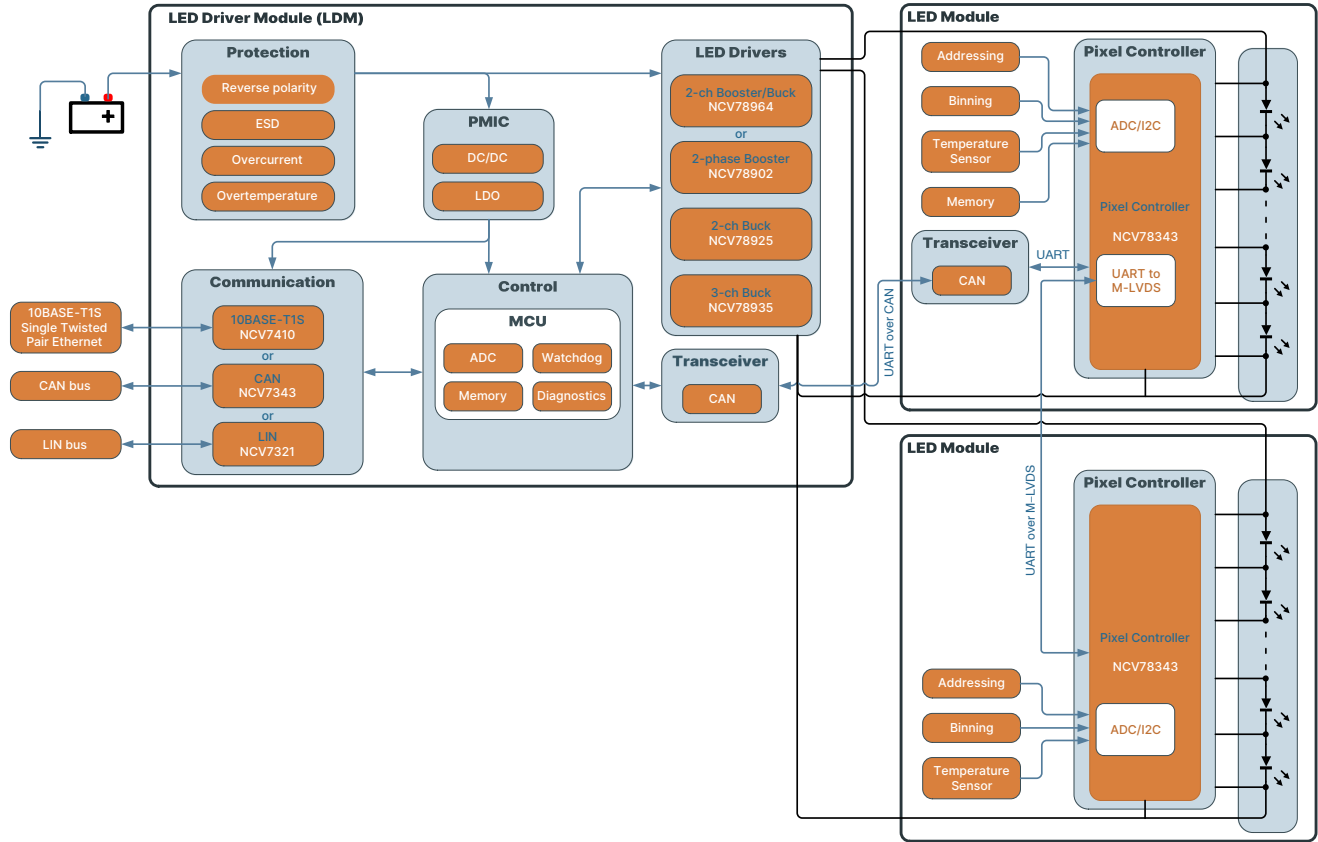

Figure 5. Multiple LED Modules Connected over M-LVDS

In this example, first NCV78343 is connected via UART over CAN to LED Driver Module. At the same time, it is acting as a bridge between UART and M-LVDS interface, translating commands that are sent between LDM and remaining devices connected to M-LVDS bus. In complex headlamps, each NCV78343 can be placed on a separate PCB. To avoid analog signal routing over a long distance, each NCV78343 can use its ADC converter to read binning resistor value or local PCB temperature. Another important

aspect is customer definable fail-safe behavior in case the communication with MCU is lost.

In case the distance between the MCU and the Pixel Controller is short enough to establish reliable SPI communication, the NCV78247 can also be used in this architecture without the need for a bridge device. To read LED temperature, binning and identification, ADC converter commonly included in majority of microcontrollers can be used.

onsemi, **Onsemi**, and other names, marks, and brands are registered and/or common law trademarks of Semiconductor Components Industries, LLC dba "**onsemi**" or its affiliates and/or subsidiaries in the United States and/or other countries. **onsemi** owns the rights to a number of patents, trademarks, copyrights, trade secrets, and other intellectual property. A listing of **onsemi**'s product/patent coverage may be accessed at www.onsemi.com/site/pdf/Patent-Marking.pdf. **onsemi** reserves the right to make changes at any time to any products or information herein, without notice. The information herein is provided "as-is" and **onsemi** makes no warranty, representation or guarantee regarding the accuracy of the information, product features, availability, functionality, or suitability of its products for any particular purpose, nor does **onsemi** assume any liability arising out of the application or use of any product or circuit, and specifically disclaims any and all liability, including without limitation special, consequential or incidental damages. Buyer is responsible for its products and applications using **onsemi** products, including compliance with all laws, regulations and safety requirements or standards, regardless of any support or applications information provided by **onsemi**. "Typical" parameters which may be provided in **onsemi** data sheets and/or specifications can and do vary in different applications and actual performance may vary over time. All operating parameters, including "Typicals" must be validated for each customer application by customer's technical experts. **onsemi** does not convey any license under any of its intellectual property rights nor the rights of others. **onsemi** products are not designed, intended, or authorized for use as a critical component in life support systems or any FDA Class 3 medical devices or medical devices with a same or similar classification in a foreign jurisdiction or any devices intended for implantation in the human body. Should Buyer purchase or use **onsemi** products for any such unintended or unauthorized application, Buyer shall indemnify and hold **onsemi** and its officers, employees, subsidiaries, affiliates, and distributors harmless against all claims, costs, damages, and expenses, and reasonable attorney fees arising out of, directly or indirectly, any claim of personal injury or death associated with such unintended or unauthorized use, even if such claim alleges that **onsemi** was negligent regarding the design or manufacture of the part. **onsemi** is an Equal Opportunity/Affirmative Action Employer. This literature is subject to all applicable copyright laws and is not for resale in any manner.

ADDITIONAL INFORMATION

TECHNICAL PUBLICATIONS:

Technical Library: www.onsemi.com/design/resources/technical-documentation
onsemi Website: www.onsemi.com

ONLINE SUPPORT: www.onsemi.com/support

For additional information, please contact your local Sales Representative at www.onsemi.com/support/sales