

Practice of Inductive Sensor Design

AND90299/D

This application note describes the principles and practical approach for the industrial and automotive inductive position sensors coil designs.

While the industrial IPS addresses high resolution and accurate solutions for Optical Incremental Encoder replacement uses in robotics, machining and domestics (like elevators), the automotive IPS address lower accuracies but with a lowest cost BOM. Below the geometry and principles of the sensors for both markets are described.

Base Structure for a Receiver Coil

Below drawings are, for clarity, shown on a straight, unwounded line. The final drawings will show the angular sensor in rotational way.

The base structure is made of segments drawn on e.g. the topmost layer and the second topmost layer of the PCB stator.

Vias connect the segments.

The coil is oriented and great care must be taken to connect the coils while respecting their orientation.

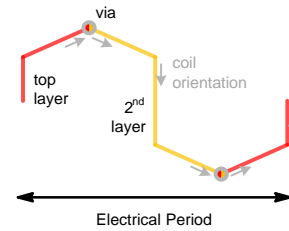

Figure 5.

In this example, a rotational receiver coil is designed with 4 counts per revolution, four base structures are connected in series to form a clockwise path, here shown as left to right:

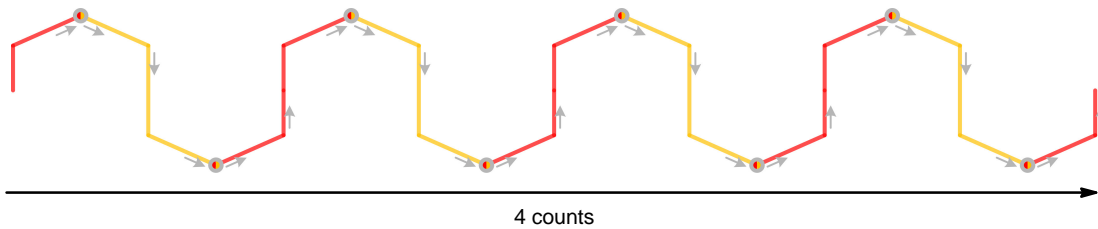

Figure 6.

Similarly, we draw a counterclockwise path, shown as right to left:

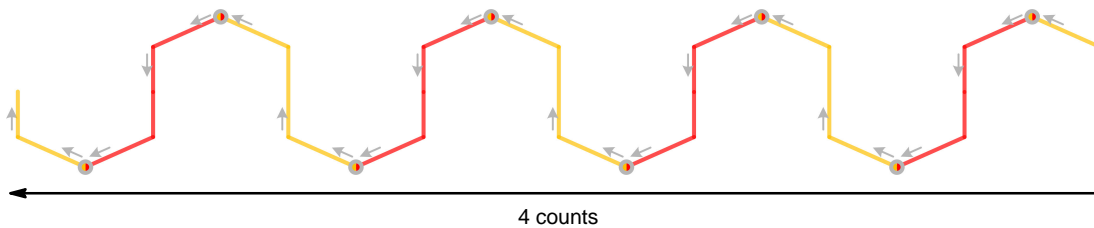

Figure 7.

We combine the clockwise and counterclockwise and connect the paths at both ends:

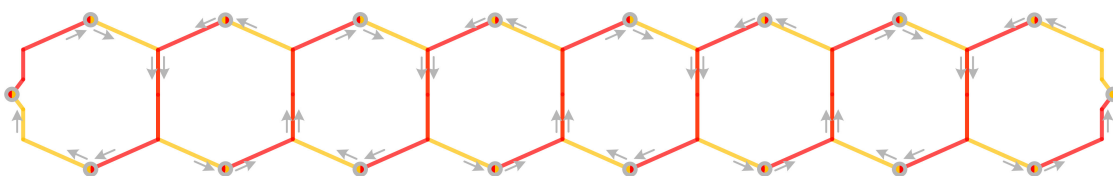

Figure 8.

We have now a very symmetrical, twisted loop coil, with alternating clockwise and counterclockwise loops.

For increased received signal amplitude, two coils can be connected in series:

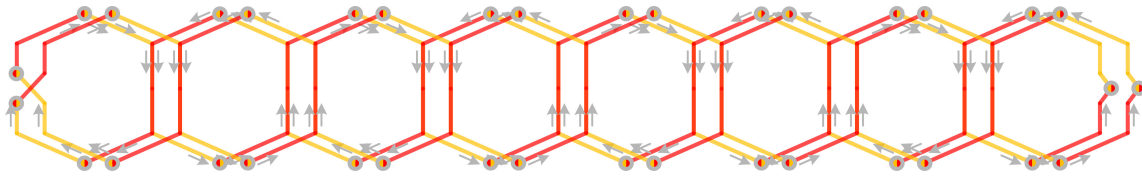

Figure 9.

Next to the receiver coil, on the same stator PCB, a multi-turn excitation coil forms a LC oscillator in which a 4 MHz current circulates. On the picture below, the excitation coil is drawn on the top layer with 3 turns.

The rotor coil, in black, is printed on an additional PCB placed above the stator PCB. Again, the reader is asked to realize that the rightmost side of the picture will be connected to the leftmost side.

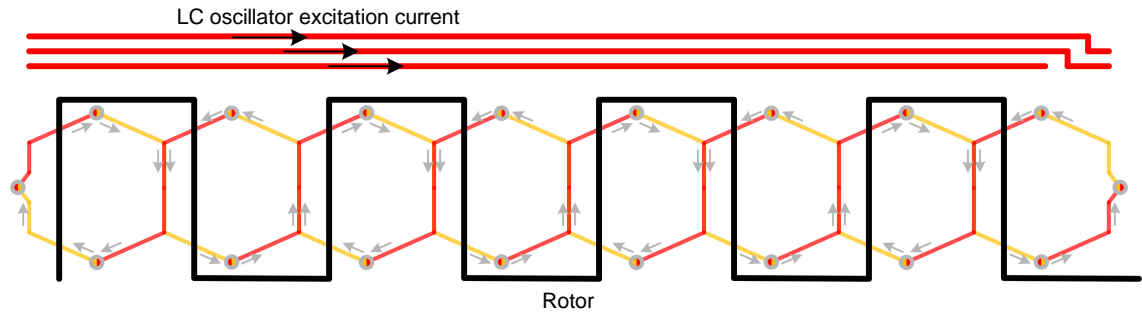

Figure 10.

A current is induced in the rotor coil due to the mutual inductance between excitation and rotor coils. This induced current amplitude decreases as the air gap between stator and rotor increases but is independent of the rotor angular position.

A single receiver coil is not enough to build an angular sensor as the received signal depends on both the air gap and the rotation. By printing on the stator PCB multiple receiver coils with a shift in phase, the air gap dependency can be eliminated in the signal processing integrated circuit.

The mutual inductance between excitation and receiver coils is minimized thanks to the twisted loop architecture of the receiver coils.

It has been shown that a 3-phase receiver structure is more accurate and more immune to external disturbances. Each phase is shifted by one third of the electrical period. It is brought to the reader's attention that the vertical segment orientations alternate every sixth of the electrical period.

The mutual inductance between the rotor and receiver coils varies not only with the air gap but also with the rotor angle. When the rotor and receiver loops are aligned, the coupling is maximum, when the loops alignment is opposite, the coupling is minimum.

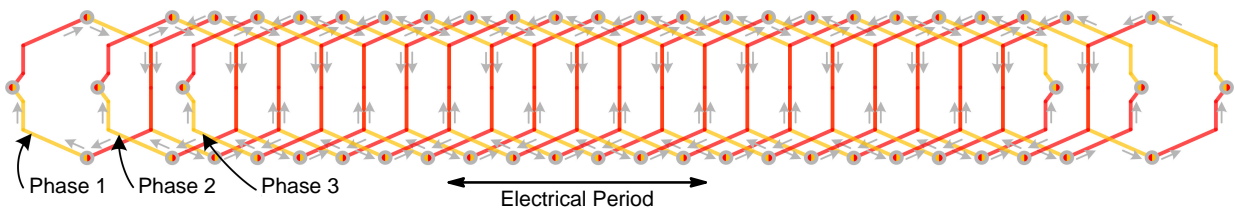

Figure 11.

AND90299/D

So far, the receiver coils are drawn as shorted coils in which induced currents, function of the rotor position,

would circulate. An electrical model of the coil structure is drawn in the figure below.

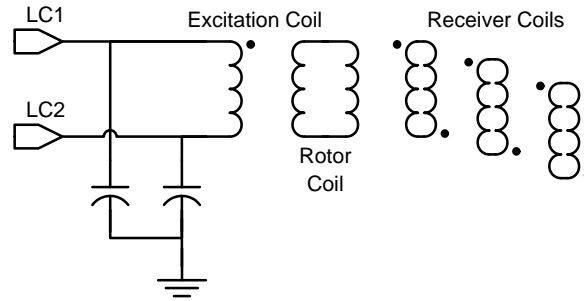

Figure 12.

This configuration is not practical for the electronic interface circuit. Instead, the receiver coils are opened and

connected to the receiver input pins while the other side is connected to a common node.

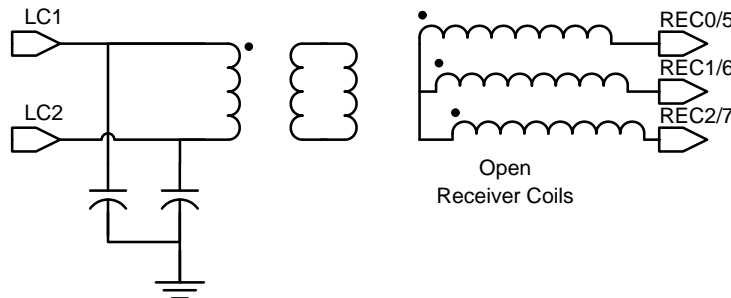

Figure 13.

A further improvement is adding a capacitor between ground and the common node. This capacitor greatly attenuates any external EM disturbance that would be

picked up by the receiver coils. Probe pads and 0 Ohm resistors allow for testing the impedance of the receiver coils (check of open or shorted coils).

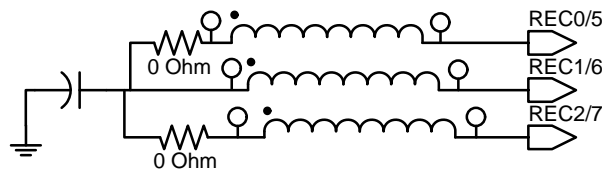

Figure 14.

Two examples of how to connect the receiver coils are shown below:

First example:

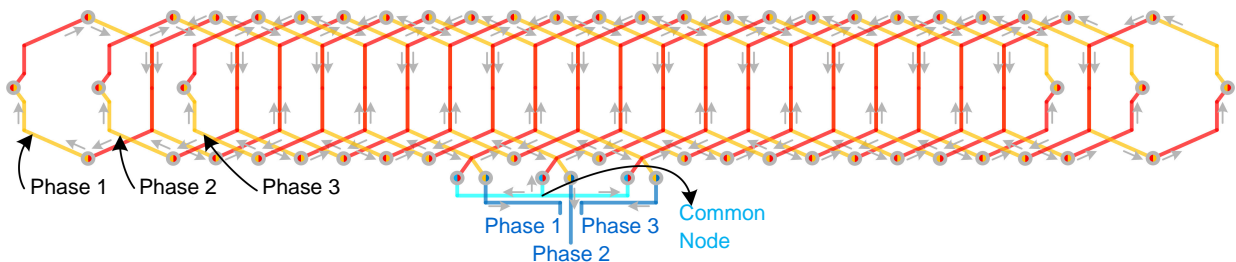

Figure 15.

First example, zoom on the connections:

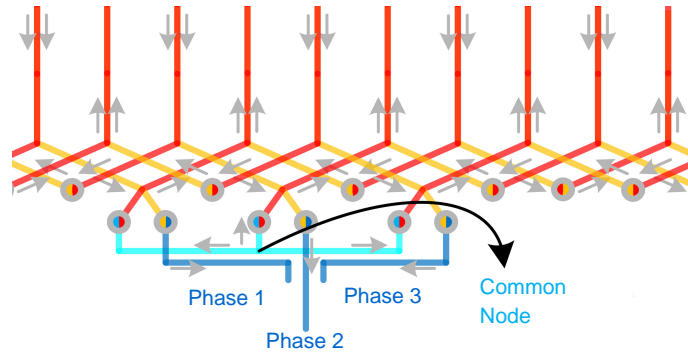

Figure 16.

It is critical to open and connect the coils with the correct orientation. As depicted with the grey arrows, the PCB tracks are oriented because the sign of the mutual inductance to the rotor depends on the segment orientation. With the first example, to open the coils, we remove every other vias at the bottom. We now have six unconnected segments, three on each PCB layer. Three segments are connected to

a common node while the other three are connected to the integrated circuit. The sensor designer must verify that the three connections follow the arrows in the same direction. In this example, the arrows leave the common node, go into the receiver coil structure, and finally enter the integrated circuit pins Phase 1, 2 and 3.

Second example:

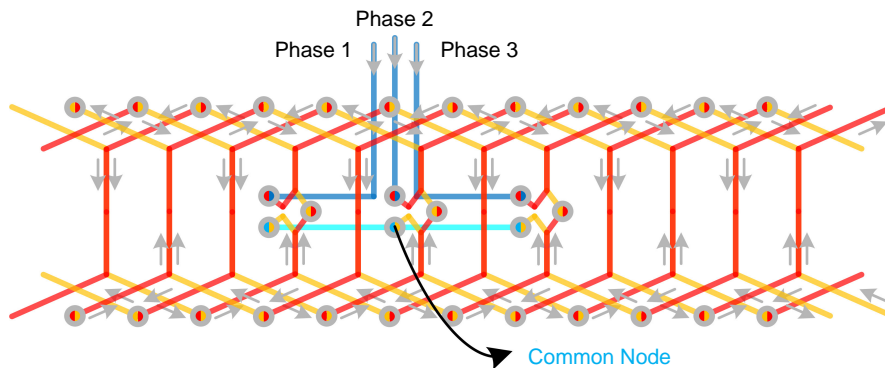

Figure 17.

In another implementation, the three vias are removed at the end of the coils. Again, the orientation is critical. Here

the arrows leave the integrated circuit pins and join at the common node.

Third example:

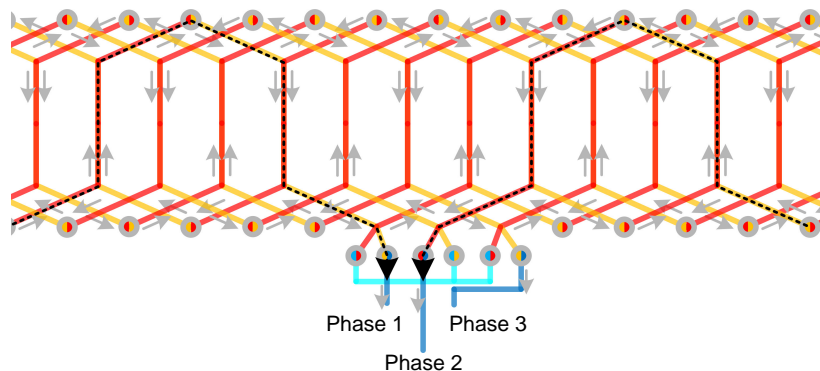

Figure 18.

The third connection example shows a design where the segments are correctly oriented to the integrated circuit pins. But it must be noted that the Phase 1 and Phase 3 coils are now from left to right while the Phase 2 coils are from right to left.

A very negative aspect of this way of connecting is that the caused asymmetry introduces an offset in the received signals caused by the asymmetric capacitive couplings to the excitation coil.

The receiver coil connections to the integrated circuit will inevitably create an asymmetry in the sensor and there will

be some direct mutual inductance coupling between the excitation coil and the receiver coil connections. These couplings are independent of the rotor position, they will be present even if the rotor is completely moved away from the stator PCB.

The drawing on the left shows tight connections with minimal disturbance to the coils' symmetry. The drawing on the right shows poor connections, forming a large loop that will pick up the excitation signal and add it to the received signal. Such design should be avoided.

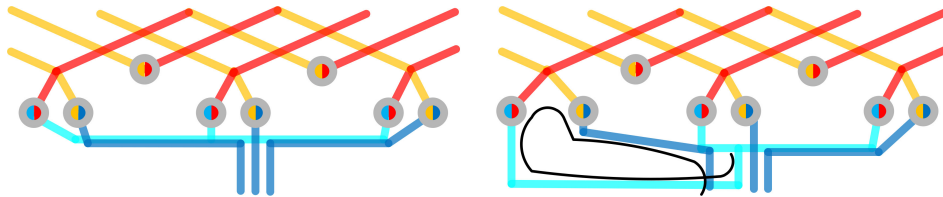

Figure 19.

In some cases, the connections between the receiver coils and the integrated circuit will be very long. Drawing two parallel tracks should be avoided as it would couple in the

excitation signal and generate an offset in the signals. Examples of twisted loops design are shown below:

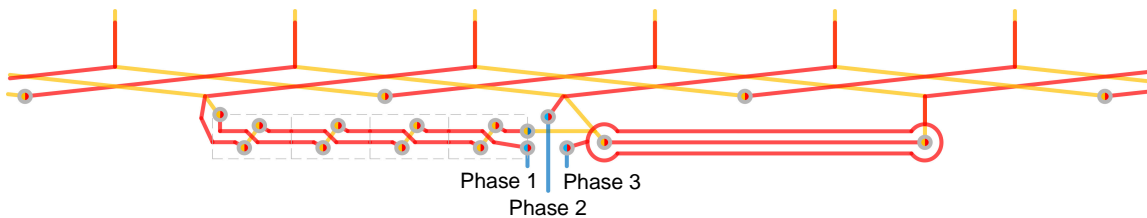

Figure 20.

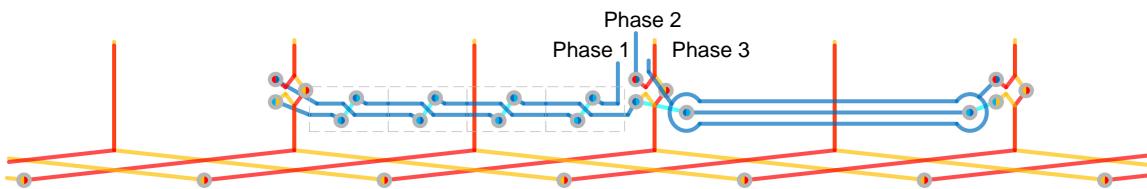

Figure 21.

The 'dog bone' pattern depicted on the right side is an alternative when the multiple vias of the twisted loop pattern are not practical.

The Rotational Sensor for Automotive Applications

If the coil structure designed according to the principles mentioned above is bent around the single point (axis of rotation), the rotary angular sensor is created. In our case the sensor has 5 electrical periods per one full mechanical rotation, so it can sense $360 / 5 = 72$ degrees.

The typical inductance for the excitation coil is between 1–2 μ H. If the inductance is lower, the excitation driver can get saturated, therefore might not be able to reach optimum

oscillation amplitude. For the excitation resonant circuit, it is recommended to use capacitors with temperature stable dielectric, so the oscillation frequency will not drift with the sensor over temperature.

For designing the rotor, it is recommended to introduce an asymmetry in 40 : 60 ratio. This will result in suppressing the 5th order harmonic distortion (even harmonics are eliminated by twisted loop receiver principle, 3rd harmonics and its multiples are eliminated by 3 coil receiver principle), therefore increasing the sensor accuracy. The rotor can be cut from the thin metal sheet (usually aluminum), or it can be made as the PCB with a thin track, because of the skin effect, the current anyway flows mostly at the circumference.

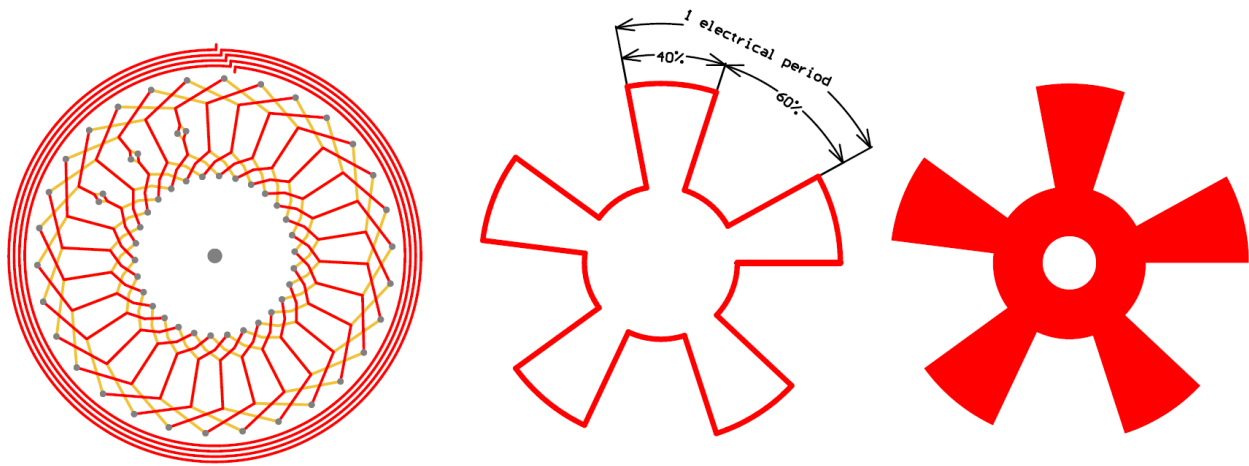

Figure 22.

For applications requiring a higher safety level, a second semi-redundant channel sensing the same rotor position might be necessary. Such a sensor can be easily created from single channel coil structure by copy – paste of the same structure rotated around the center axis by $360 / \text{electrical periods} / 12$, in this case $360 / 5 / 12 = 6$ degrees, to interleave

the existing coil structure. The coil can be rotated by additional electrical period angle, in this case 72 degrees as shown in the picture below, so the 12 vias in the middle of the coil structure do not collide between each other. For the same reason, excitation coil needs to be transferred into another layer.

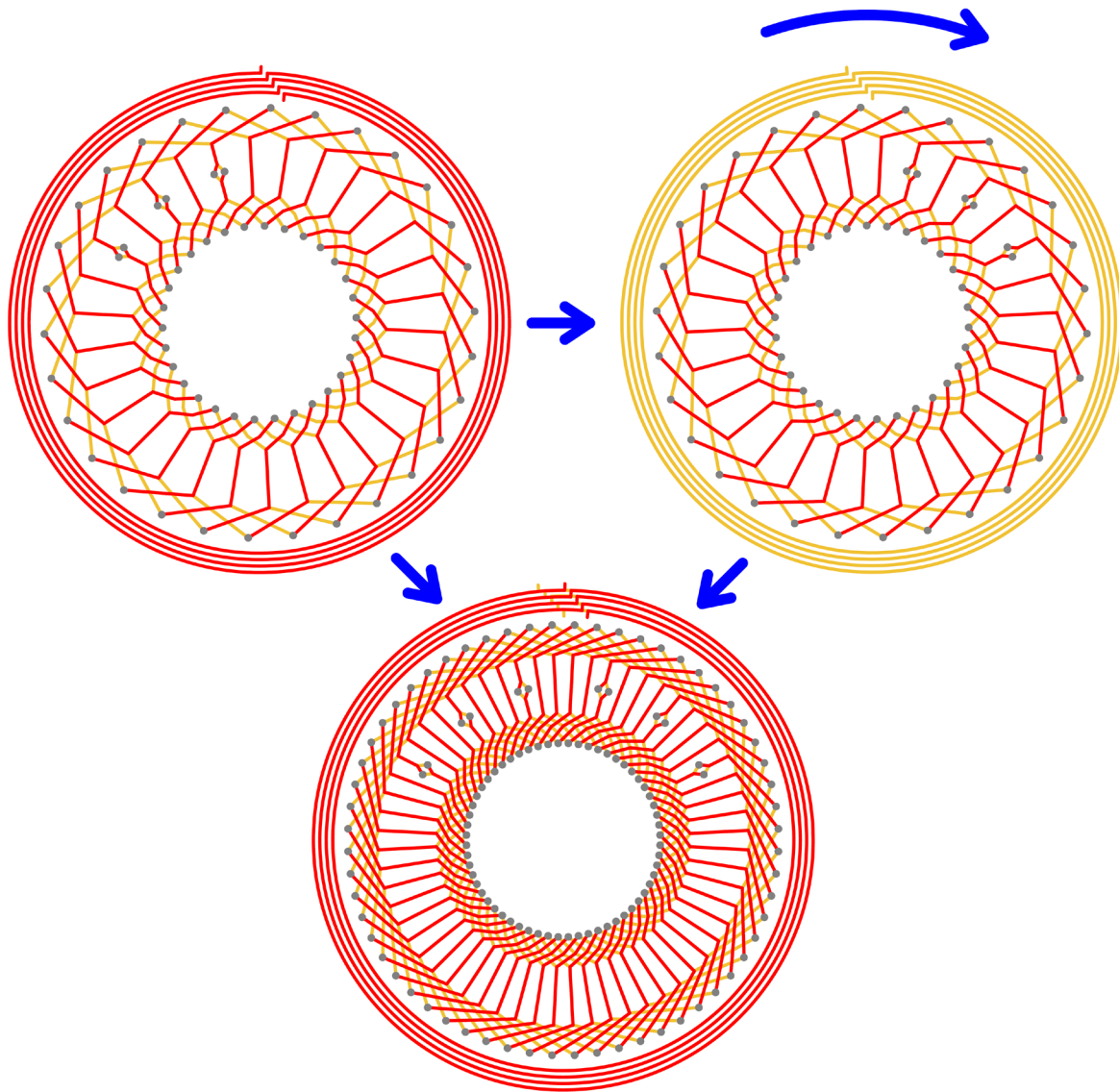

Figure 23.

It is possible to design a sensor coil structure, which will not cover a full circle, as shown in the picture below. It is still a 5 pole (electrical period) sensor sensing 72 degrees, so the rotor is still the same, but 2 electrical periods were removed from the stator layout. This will certainly decrease the received signal amplitude compared to the full circle sensor, but the main advantage is, that it can be mounted aside of the shaft, not only through the hole of the sensor or at the end of the shaft. The disadvantages are similar to the linear sensor, so it is more sensitive to mechanical misalignment such as X and Y offset or rotor tilt. Full circle sensors are less sensitive to misalignment, because they are almost perfectly symmetrical around the center point. E.g. if the tilt is assumed, the rotor is closer to the stator on one side, but it is further away from the other side, so it is partially averaging out.



Figure 24.

AND90299/D

With a dual channel sensor coil structure, two main configurations are possible. This is shown in Figure 25 and 26. In Figure 25, channel 1 and channel 2 are fully galvanically separated on the sensor. Every chip has its own ground, supply, output, set of receiver coils and its own excitation coil. However, there is still a strong mutual coupling between the two excitation coils, so they will create

a coupled resonance circuit and they will both oscillate at common frequency and phase, therefore they will drive the electromagnetic field around the sensor together. If there is some issue at the excitation circuit in one chip, the other chip can still drive the resonator and if the receiver amplitude is sufficient, it might still provide correct position.

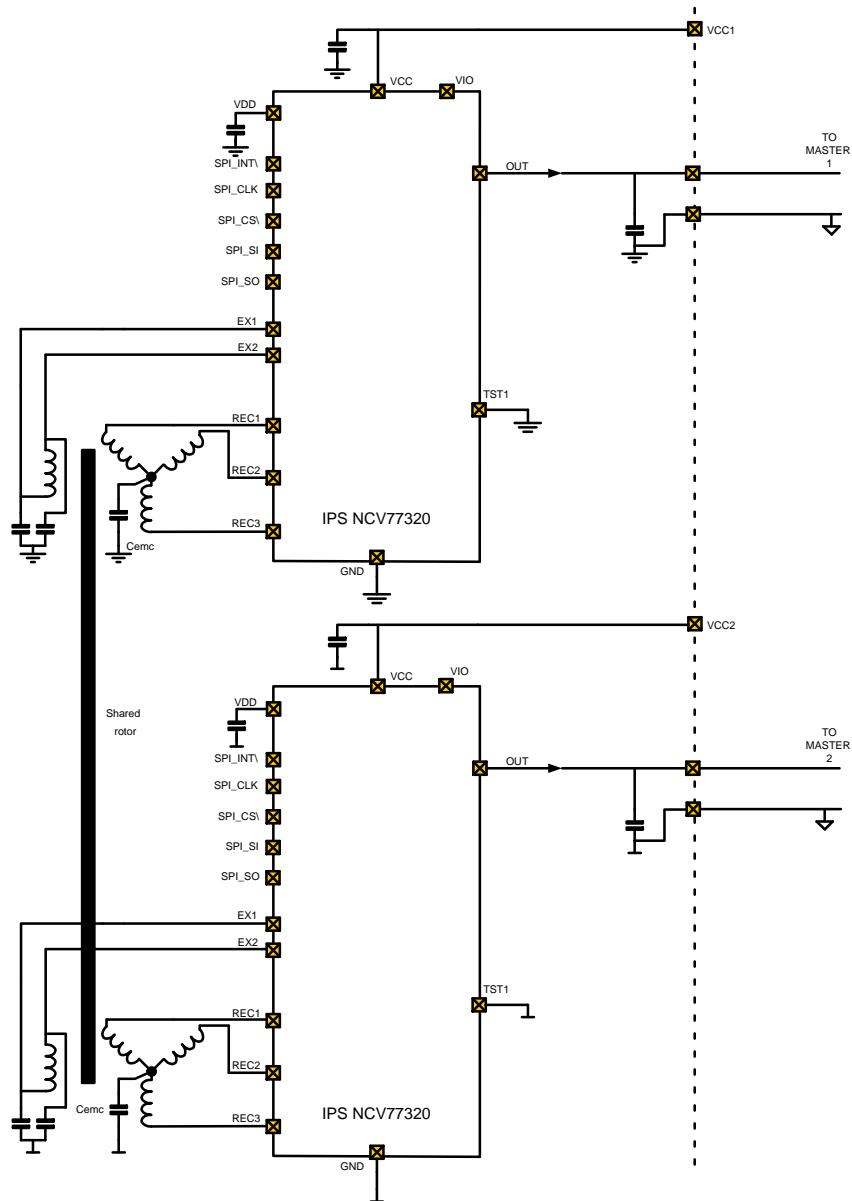

Figure 25.

Another possibility is to use configuration shown in Figure 26. In this case, chips share supply and ground, therefore they can share the excitation coil by galvanically connecting EX1 and EX2 to the single excitation coil. This can possibly allow to use only 2-layer PCB for a dual sensor, so the connections from the receiver coils can cross the excitation coil on the other layer and be connected to the ICs

(4 layer PCB is recommended because it allows better layout and proper grounding on the sensor resulting in better EMC performance). Regardless of the selected configuration for a dual coil sensor, “inp_diag_per” (address 8, bit 11) shall be programmed differently for each device for proper function of the inter-coil short detection mechanism.

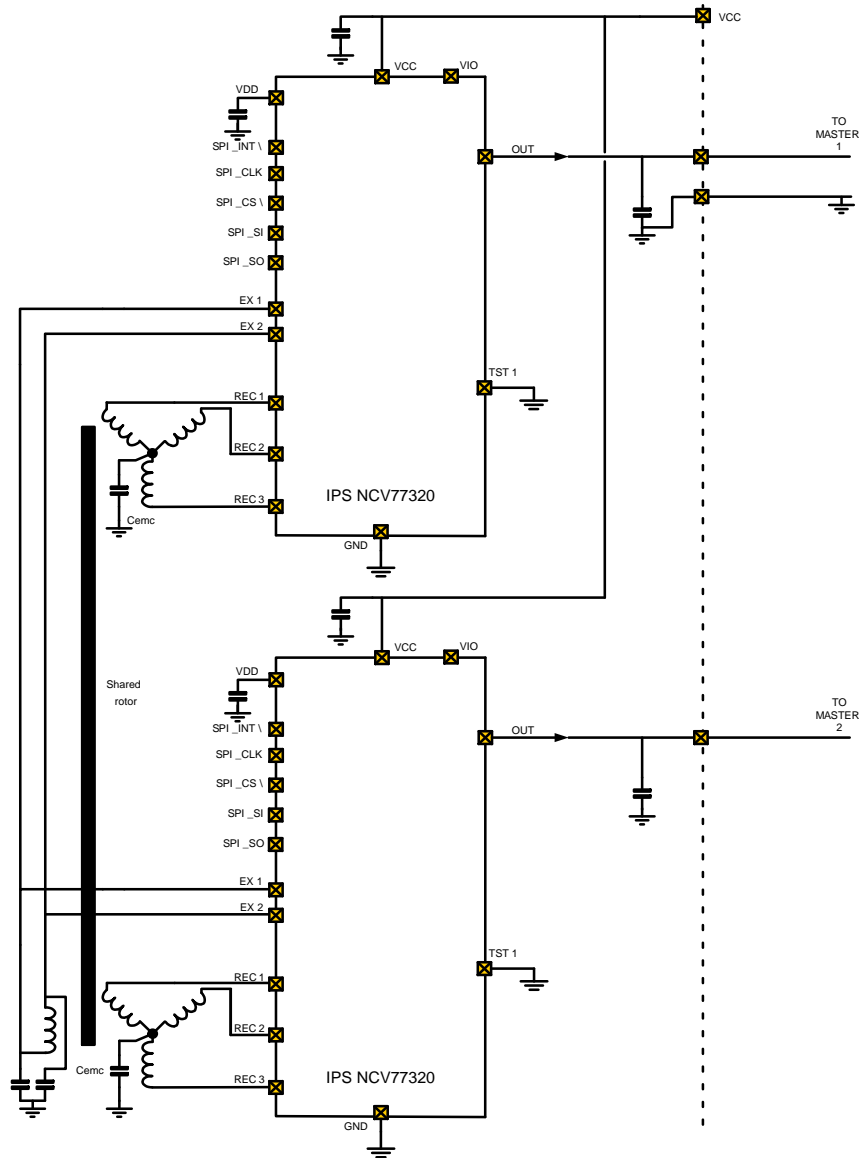

Figure 26.

Layout Recommendations

Propper layout around the IC is essential for good EMC performance. An example of a layout around the NCV77320 can be seen below.

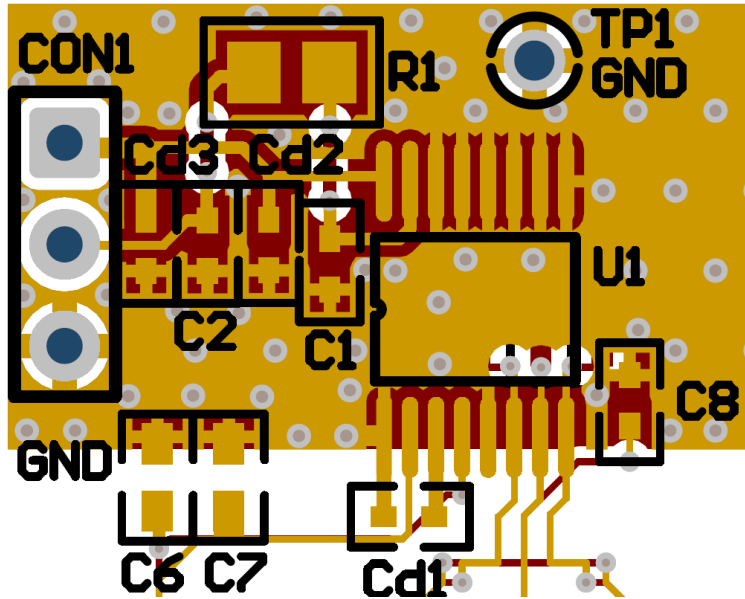

Figure 27.

Cd1 is a decoupling capacitor for the chip with its internal 3.3 V regulator. It is important, that it is connected as close as possible to pin 1 (chip main ground pin) and pin 3 (Vdd). C1 is the output capacitor, it should be close to the pin 15 (OUT) and the other side of the capacitor should have a low ground impedance path to the main ground pin 1 (no changing layers through vias or around some PCB trace).

The same applies to Cd2, which is a Vcc pin decoupling capacitor. Cd3 and C2 are placed close to the connector, which is beneficial for ESD performance. If there are more layers with poured ground, it is recommended to use enough vias to create a low impedance ground layer. Another example of a full sensor layout can be seen in the following picture.

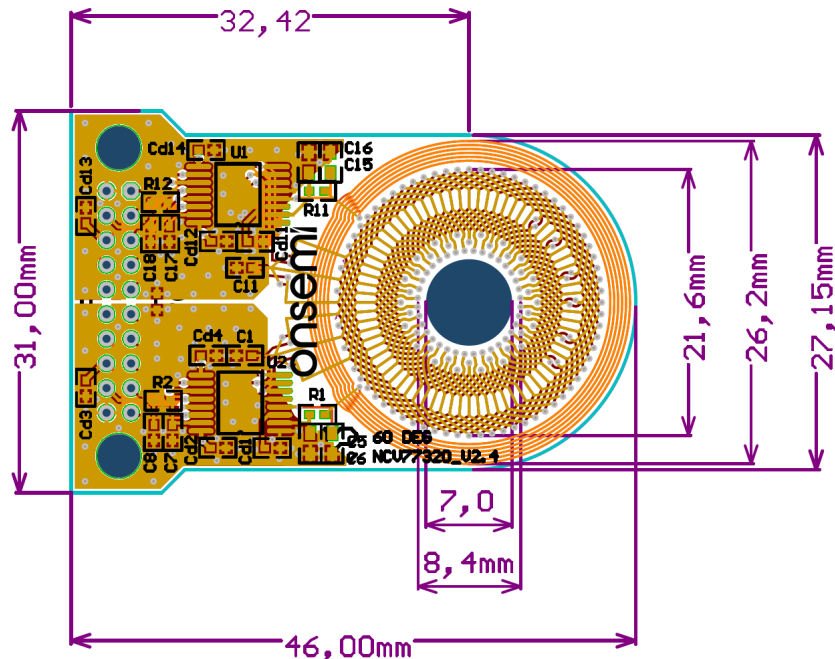

Figure 28.

This is a 6 electrical period sensor (sensing 60-degree mechanical angle), with dual coil structure, split supplies and grounds. Such a sensor can be used, e.g. for a pedal application. The typical airgap for a sensor like this is around 1.5–2 mm, but the sensor can reasonably work between ~ 1 to 3 mm. If a bigger airgap is required, the sensor would need to be also bigger.

NOTE: Maybe such a sensor could be still a bit smaller, but as can be seen in the picture, the area of the coil structure is already densely populated with vias and tracks, so that would likely mean more expensive PCB process due to thin tracks and small vias.

The Rotational Sensor for Industrial Applications

For high resolution and high accuracy applications, commonly found in industrial sensors, the designs make use of the Vernier principle, like the caliper. The NCS32100 device is specifically designed for these kind of applications.

So, in other words, one full rotational sensor can be made much more accurate when 2 receiver structures are made of a course (like mm on the caliper) and fine (like 0.1 mm on the caliper), each receiver structure is coupled to a rotor coil matching the number of pole pair numbers of the receiver. The rotor coil is double lined for better accuracy.

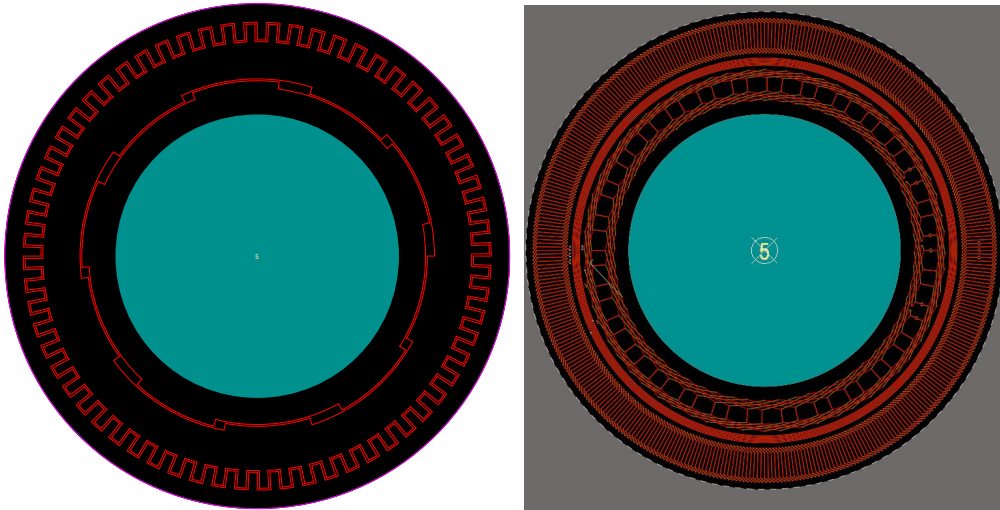

Figure 29. Dual Channel Sensor as Generated by the Design Tool

Connections from the Y star receiver structure are placed in this picture. A zoom in is shown below. From the discussion in the first sessions of this document it should be clear where the Device (NCS32100) should be connected to. Please refer to Application note AND90191/D that describes the applications with the NCS32100 in more detail.

References

- Datasheet NCV77320
- Datasheet NCS32100
- Application Note AND90191/D
- Application Note TND6427/D

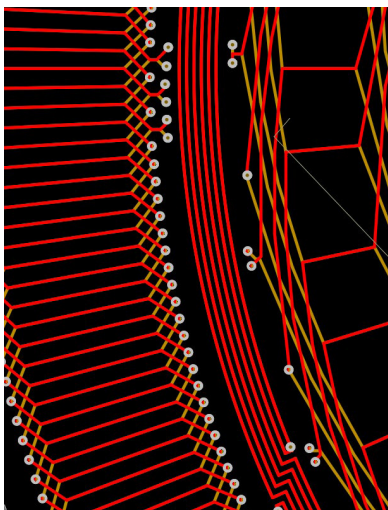

Figure 30.

onsemi, **Onsemi**, and other names, marks, and brands are registered and/or common law trademarks of Semiconductor Components Industries, LLC dba "**onsemi**" or its affiliates and/or subsidiaries in the United States and/or other countries. **onsemi** owns the rights to a number of patents, trademarks, copyrights, trade secrets, and other intellectual property. A listing of **onsemi**'s product/patent coverage may be accessed at www.onsemi.com/site/pdf/Patent-Marking.pdf. **onsemi** reserves the right to make changes at any time to any products or information herein, without notice. The information herein is provided "as-is" and **onsemi** makes no warranty, representation or guarantee regarding the accuracy of the information, product features, availability, functionality, or suitability of its products for any particular purpose, nor does **onsemi** assume any liability arising out of the application or use of any product or circuit, and specifically disclaims any and all liability, including without limitation special, consequential or incidental damages. Buyer is responsible for its products and applications using **onsemi** products, including compliance with all laws, regulations and safety requirements or standards, regardless of any support or applications information provided by **onsemi**. "Typical" parameters which may be provided in **onsemi** data sheets and/or specifications can and do vary in different applications and actual performance may vary over time. All operating parameters, including "Typicals" must be validated for each customer application by customer's technical experts. **onsemi** does not convey any license under any of its intellectual property rights nor the rights of others. **onsemi** products are not designed, intended, or authorized for use as a critical component in life support systems or any FDA Class 3 medical devices or medical devices with a same or similar classification in a foreign jurisdiction or any devices intended for implantation in the human body. Should Buyer purchase or use **onsemi** products for any such unintended or unauthorized application, Buyer shall indemnify and hold **onsemi** and its officers, employees, subsidiaries, affiliates, and distributors harmless against all claims, costs, damages, and expenses, and reasonable attorney fees arising out of, directly or indirectly, any claim of personal injury or death associated with such unintended or unauthorized use, even if such claim alleges that **onsemi** was negligent regarding the design or manufacture of the part. **onsemi** is an Equal Opportunity/Affirmative Action Employer. This literature is subject to all applicable copyright laws and is not for resale in any manner.

ADDITIONAL INFORMATION

TECHNICAL PUBLICATIONS:

Technical Library: www.onsemi.com/design/resources/technical-documentation
onsemi Website: www.onsemi.com

ONLINE SUPPORT: www.onsemi.com/support

For additional information, please contact your local Sales Representative at www.onsemi.com/support/sales