

NB7NQ621M for Source and Sink Side Application

AND90182/D

INTRODUCTION

This application note gives a setting for meeting HDMI 2.1 TMDS and FRL Compliance when NB7NQ621M HDMI redriver is used on both Source and Sink Side using different I²C settings.

The application note is to be used along with the NB7NQ621M Datasheet. This application note shows a method of implementation.

Background

Figure 1 shows a typical customer application setup connection. The FPGA is connected to Source TX and to the Sink RX of the NB7NQ621M redriver.

The system will require multiple settings and different operation data rate. NB7NQ621M has suitable I²C register value at TMDS mode and FRL mode to meet the compliance.

FPGA have capability to dynamically detect the resolution rate as per the configuration of the NB7NQ621M redriver operating mode.

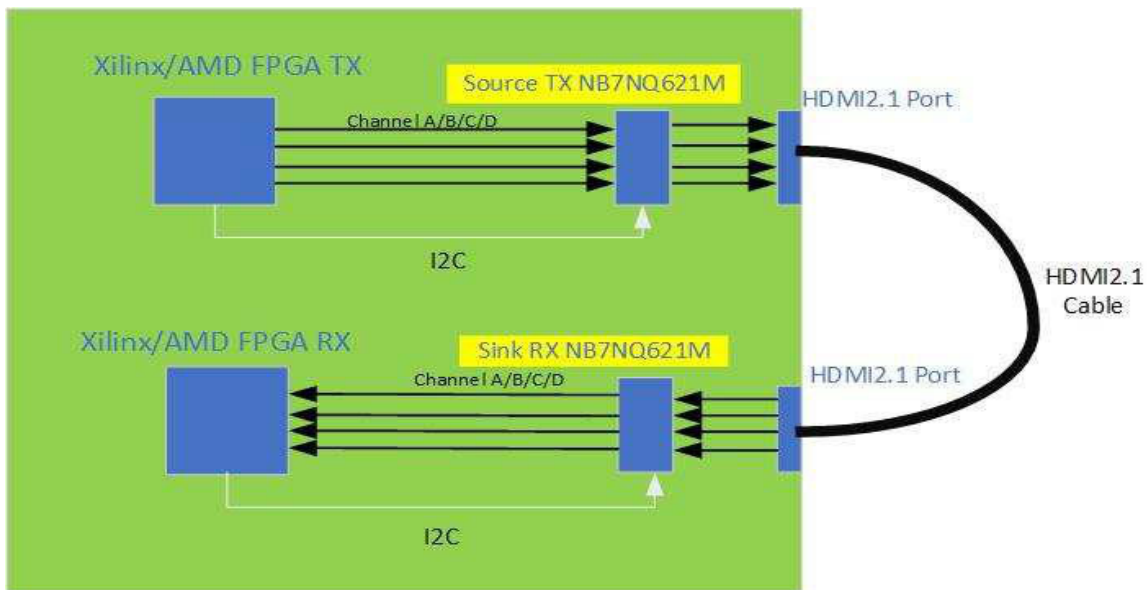

Figure 1. Typical Source Sink System Configuration

AND90182/D

A Typical Source and Sink Side Schematic is shown below for reference. Figure 2 shows the Source Side Schematic and Figure 3 shows the Sink Side Schematic around the NB7NQ621M redriver.

Source Side Schematic

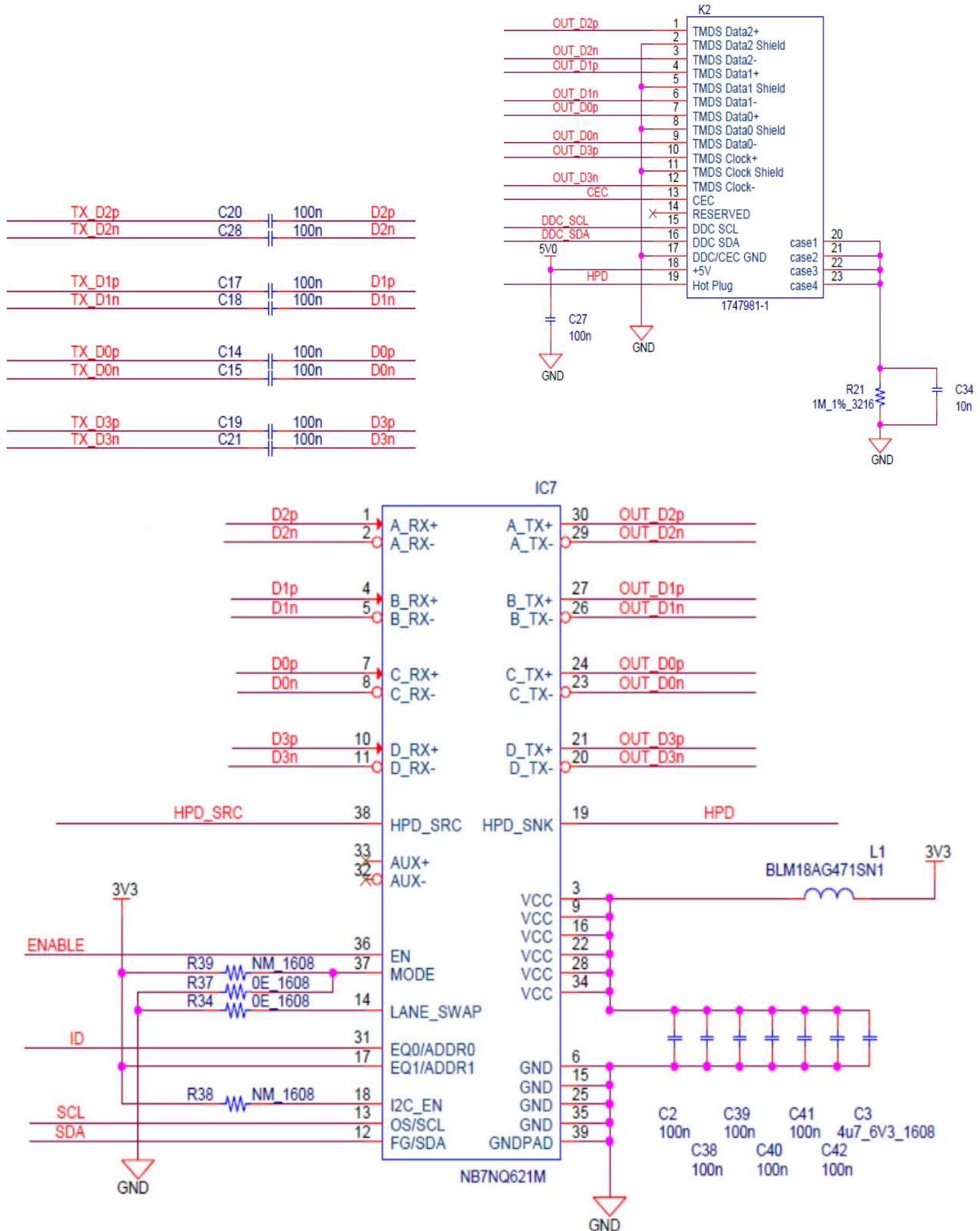

Figure 2. Source Side Circuit

AND90182/D

Sink Side Schematic

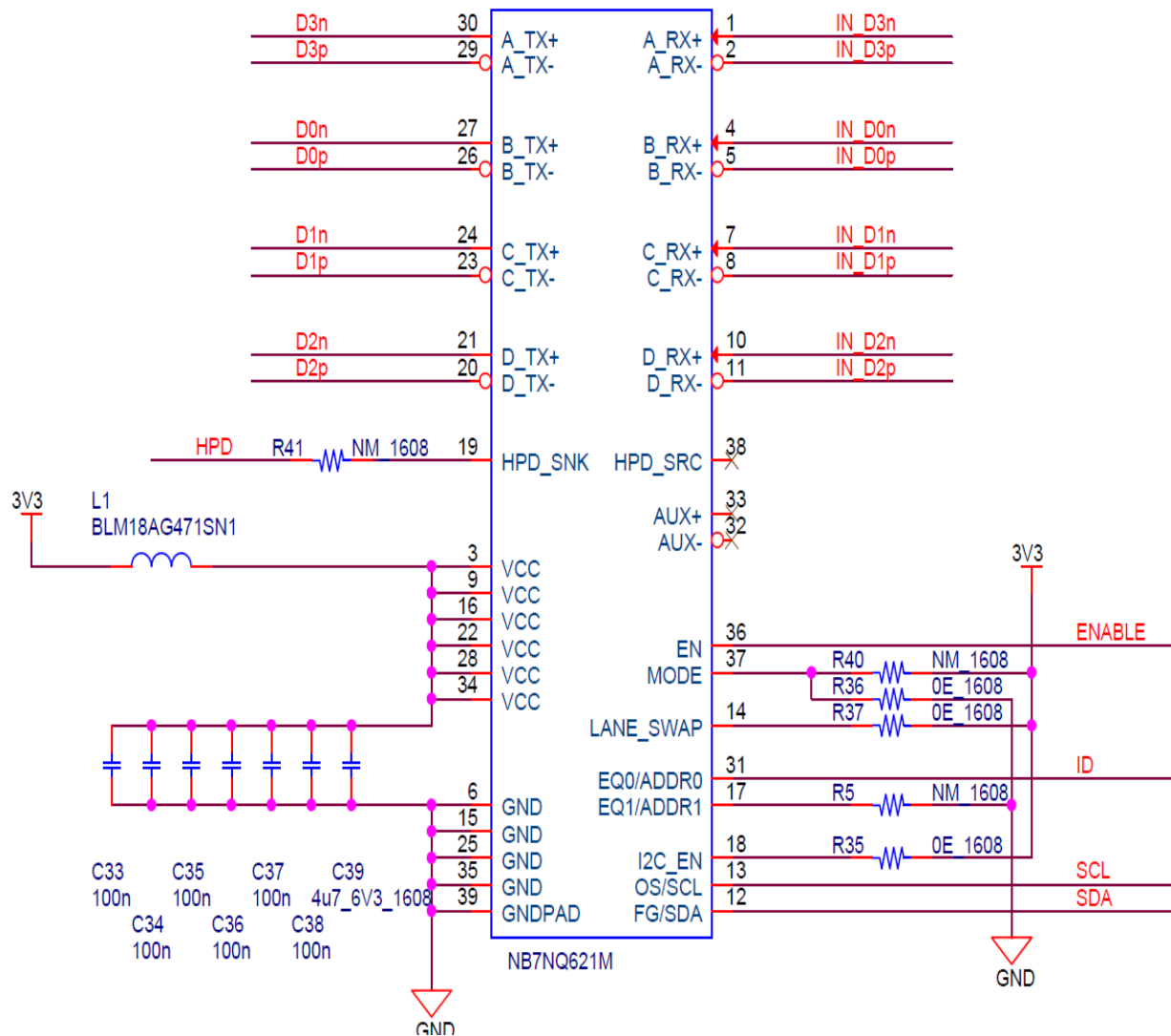
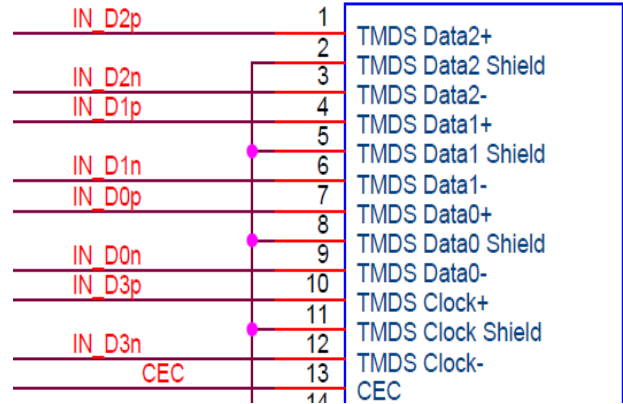
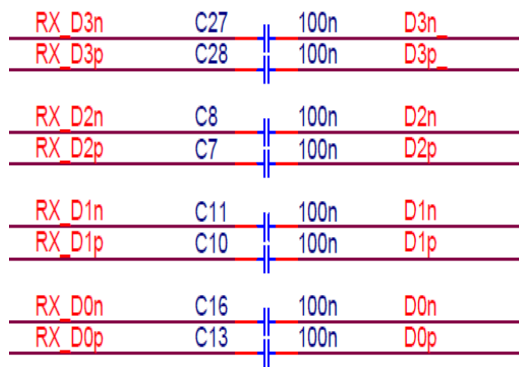

Figure 3. Sink Side Circuit

AND90182/D

Given below Tables 1 to 4 showing the I²C setting meeting the Compliance for the Source side TX Source and Table 5 to 7 showing I²C settings for RX Sink Side meeting the Compliance for different Modes.

Table 1. NB7NQ621M I²C SETTING FOR SOURCE TX HDMI 1.4 TMDS UNDER 1.65 Gbps DATA RATE

Register	Setting	Remarks
0x0A	04	Global control, Line to Line Hi-Z, Mode 0, Short circuit block disable
0x0B	0F	
0x0C	00	
0x0D	31	CLK FG = 4.5 dB, OS = 1200 mV
0x0E	03	CLK Slew Rate fast, EQ level 3
0x0F	31	Data FG = 4.5 dB, OS = 1200 mV
0x10	03	Data Slew Rate fast, EQ level 3
0x11	0F	
0x12	AA	
0x13	30	
0x14	0F	
0x15	00	
0x16	02	
0x17	63	
0x18	00	
0x19	00	
0x1A	03	
0x1B	00	
0x1C	00	
0x1D	03	
0x1E	00	

AND90182/D

Table 2. NB7NQ621M I²C SETTING FOR SOURCE TX HDMI 1.4 TMDS 1.65 Gbps TO 3.4 Gbps DATA RATE

Register	Setting	Remarks
0x0A	0C	Global control, Line to Line 300 Ohms, Mode 1, Short circuit block disable
0x0B	0F	
0x0C	00	
0x0D	31	CLK FG = 4.5 dB, OS = 1200 mV
0x0E	03	CLK Slew Rate fast, EQ level 3
0x0F	31	Data FG = 4.5 dB, OS = 1200 mV
0x10	03	Data Slew Rate fast, EQ level 3
0x11	0F	
0x12	AA	
0x13	30	
0x14	0F	
0x15	00	
0x16	02	
0x17	63	
0x18	00	
0x19	00	
0x1A	03	
0x1B	00	
0x1C	00	
0x1D	03	
0x1E	00	

Table 3. NB7NQ621M I²C SETTING FOR SOURCE TX HDMI 2.1 TMDS 3.4 Gbps TO 6 Gbps DATA RATE

Register	Setting	Remarks
0x0A	1C	Global control, Line to Line 100 Ohms, Mode 3, Short circuit block disable
0x0B	0F	
0x0C	00	
0x0D	31	CLK FG = 4.5 dB, OS = 1200 mV
0x0E	03	CLK Slew Rate fast, EQ level 3
0x0F	31	Data FG = 4.5 dB, OS = 1200 mV
0x10	03	Data Slew Rate fast, EQ level 3
0x11	0F	
0x12	AA	
0x13	02	
0x14	0F	
0x15	00	
0x16	02	
0x17	63	
0x18	00	
0x19	00	
0x1A	03	
0x1B	00	
0x1C	00	
0x1D	03	
0x1E	00	

AND90182/D

Table 4. NB7NQ621M I²C SETTING FOR SOURCE TX HDMI 2.1 FRL 12 Gbps DATA RATE

Register	Setting	Remarks
0x0A	24	Global control, FRL DC Coupling, Mode 4, Short circuit block disable
0x0B	0D	Disable HPD Automatic power down function
0x0C	00	
0x0D	31	CLK FG = 4.5 dB, OS = 1200 mV
0x0E	03	CLK Slew Rate fast, EQ level 3
0x0F	31	Data FG = 4.5 dB, OS = 1200 mV
0x10	03	Data Slew Rate fast, EQ level 3
0x11	0F	
0x12	AA	
0x13	00	
0x14	03	
0x15	00	
0x16	00	
0x17	03	
0x18	00	
0x19	00	
0x1A	03	
0x1B	00	
0x1C	00	
0x1D	03	
0x1E	00	

Table 5. NB7NQ621M I²C SETTING FOR SINK RX HDMI 1.4 TMDS UNDER 3.4 Gbps DATA RATE

Register	Setting	Remarks
0x0A	1C	Global control, Line to Line 100 Ohms, Mode 3, Short circuit block disable
0x0B	0D	Disable HPD Automatic power down function
0x0C	00	
0x0D	00	CLK FG = 0 dB, OS = 1000 mV
0x0E	03	CLK Slew Rate fast, EQ level 3
0x0F	21	Data FG = 1.5 dB, OS = 1200 mV
0x10	2A	Data Slew Rate fast, EQ level 10
0x11	0F	
0x12	00	
0x13	00	
0x14	03	
0x15	00	
0x16	00	
0x17	03	
0x18	00	
0x19	00	
0x1A	03	
0x1B	00	
0x1C	00	
0x1D	03	
0x1E	00	

AND90182/D

Table 6. NB7NQ621M I²C SETTING FOR SINK RX HDMI 2.1 TMDS 3.4 Gbps TO 6 Gbps DATA RATE

Register	Setting	Remarks
0x0A	1C	Global control, Line to Line 100 Ohms, Mode 3, Short circuit block disable
0x0B	0D	Disable HPD Automatic power down function
0x0C	00	
0x0D	00	CLK FG = 0 dB, OS = 1000 mV
0x0E	03	CLK Slew Rate fast, EQ level 3
0x0F	21	Data FG = 1.5 dB, OS = 1200 mV
0x10	2A	Data Slew Rate fast, EQ level 10
0x11	0F	
0x12	00	
0x13	00	
0x14	03	
0x15	00	
0x16	00	
0x17	03	
0x18	00	
0x19	00	
0x1A	03	
0x1B	00	
0x1C	00	
0x1D	03	
0x1E	00	

Table 7. NB7NQ621M I²C SETTING FOR SINK RX HDMI 2.1 FRL 12 Gbps DATA RATE

Register	Setting	Remarks
0x0A	24	Global control, FRL DC Coupling, Mode 4, Short circuit block disable
0x0B	0D	Disable HPD Automatic power down function
0x0C	00	
0x0D	21	CLK FG = 1.5 dB, OS = 1200 mV
0x0E	01	CLK Slew Rate fast, EQ level 1
0x0F	21	Data FG = 1.5 dB, OS = 1200 mV
0x10	01	Data Slew Rate fast, EQ level 1
0x11	0F	
0x12	33	
0x13	21	
0x14	00	
0x15	00	
0x16	21	
0x17	00	
0x18	00	
0x19	21	
0x1A	00	
0x1B	00	
0x1C	20	
0x1D	07	
0x1E	00	

Additional Guidelines

In addition to the above settings, below guidelines also need to be followed for passing compliance:

- For passing HFR 2-1, HFR 2-2 and HFR 2-3 Sink HDMI 2.1 Intrapair skew and Inter pair skew, the data path of layout between the intra pair and inter pair skew must under 2 mil. Also, the component pad must be etched at reference plan. An example Layout routing is shown in Figure 5 below.
- The HDMI connector selected should be of the HDMI category 3 certification connector and also must be of the SMT type.

- There is no need in the system for tuning the FPGA PHY of firmware and software setting. We just need tuning the EQ, Flat gain and output swing setting of NB7NQ621M redriver depending on the channel signal quality.
- For the eye diagram pre-check, user can make use of the chipset IBERT IP tool for Eye Diagram Analyzer. Below Figure 4 photo shows an example tool screen If this is done, then there will be no need for use of Scope or BERT test before going to the certification test.

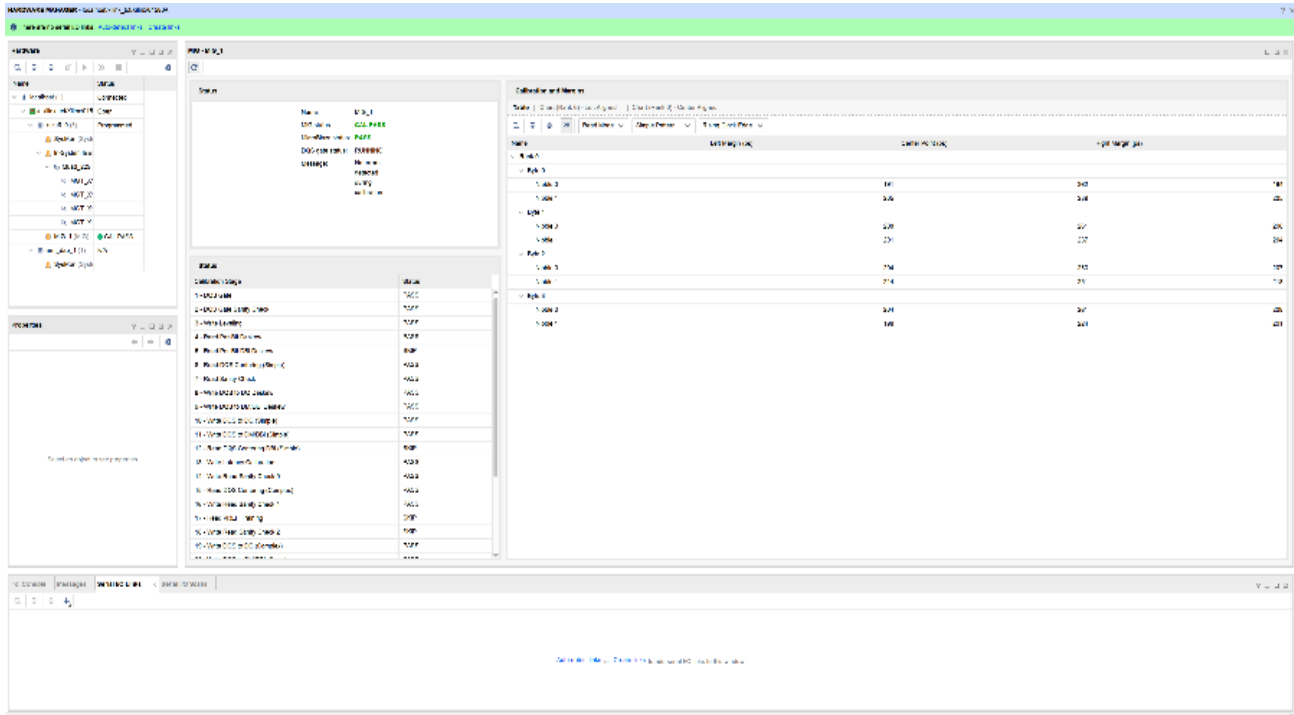

Figure 4. Sample IBERT IP Tool

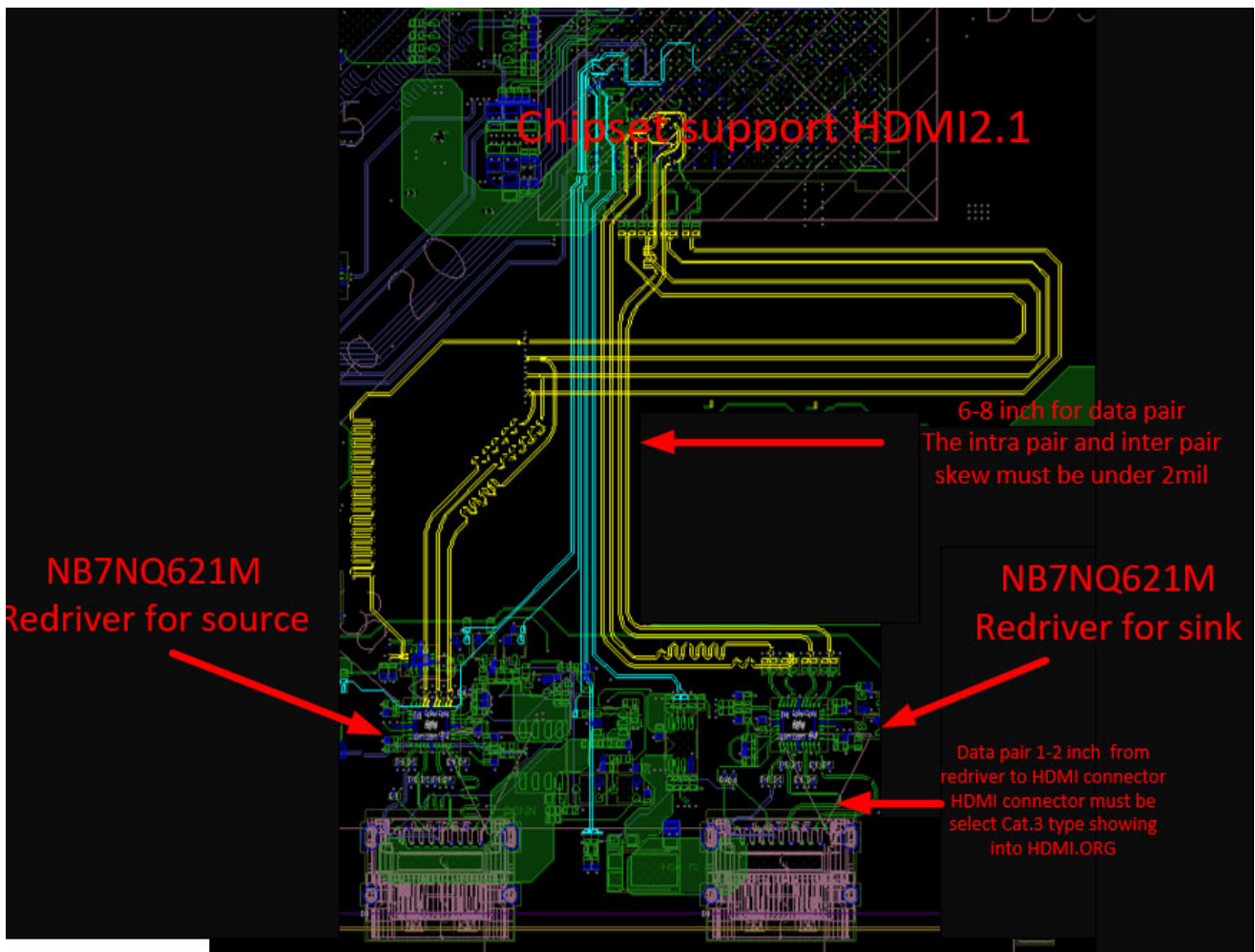

Figure 5. Example of Layout Routing

AND90182/D

Given below are the brief Summary of the Compliance results from one of the Systems using NB7NQ621M tested at a certified Lab. Table 8 shows Source Side Test results and Table 9 Shows the Sink Side Test Results.

Table 8. SOURCE SIDE TEST RESULT SUMMARY

Test Item		Result
HDMI 2.1 FRL Electrical	Test ID HFR 1-1: DC Common Mode	Pass
	Test ID HFR 1-2: Vse_max, Vse_min	Pass
	Test ID HFR 1-3: TRISE, TFALL	Pass
	Test ID HFR 1-4: Inter-Pair Skew	Pass
	Test ID HFR 1-5: TMDS / FRL Rates	Pass
	Test ID HFR 1-6: Data Jitter (Rj)	Pass
	Test ID HFR 1-7: Data Eye Diagram	Pass
	Test ID HFR 1-8: AC Common Mode Noise	Pass
	Test ID HFR 1-9: FFE	Pass
HDMI 2.1 TMDS Electrical	Test ID HF 1-1: VL and Vswing	Pass
	Test ID HF 1-2: TRISE, TFALL	Pass
	Test ID HF 1-3: Inter-Pair Skew	Pass
	Test ID HF 1-4: Intra-Pair Skew	Pass
	Test ID HF 1-5: Differential Voltage	Pass
	Test ID HF 1-6: Clock Duty Cycle and Clock Rate	Pass
	Test ID HF 1-7: Clock Jitter	Pass
	Test ID HF 1-8: Data Eye Diagram	Pass
	Test ID HF 1-9: Differential impedance test	Pass
HDMI 1.4 TMDS Electrical	7-2 Low Level Output Voltage (VL)	Pass
	7-4 Rise/Fall Time	Pass
	7-5 Overshoot/Undershoot	Pass
	7-6 Inter-pair Skew	Pass
	7-7 Intra-pair Skew	Pass
	7-8 Clock Duty Cycle	Pass
	7-9 Clock Jitter	Pass
	7-10 Data Eye Diagram	Pass

Given below are some suggestion and notes that will help to pass Compliance:

1. Set the redriver slew rate setting to slew1 or slew2 for passing HDMI 1.4 7-4 Rise/Fall Time test.
2. Set the redriver output swing = 1000 mV for pass HDMI 1.4 7-2 low level output voltage (VL) test.
3. Set the redriver line to line impedance to 100 Ohm for pass the HDMI 2.1 HF 1-9 differential impedance test.
4. Set the redriver EQ level under level 3 for passing HDMI 2.1 FRL HFR1-7 eye diagram test.
5. Make sure the data pair of length pair to pair mismatch is under 2 mil and select the HDMI category 3 certification connector for passing the HDMI 2.1 FRL HFR 1-4 Inter-Pair Skew.

Table 9. SINK SIDE TEST RESULT SUMMARY

Test Item		Result
HDMI 2.1 FRL Electrical	Test ID HFR 2-1: Max Differential Swing Tolerance	Pass
	Test ID HFR 2-2: Intra-Pair Skew	Pass
	Test ID HFR 2-3: Inter-Pair Skew	Pass
	Test ID HFR 2-4: Minimum Link Rate Tolerance	Pass
	Test ID HFR 2-5: Jitter Tolerance	Pass
HDMI 2.1 TMDS Electrical	Test ID HF 2-1: Min/Max Differential Swing Tolerance	Pass
	Test ID HF 2-2: Intra-Pair Skew	Pass
	Test ID HF 2-3: Jitter Tolerance	Pass
HDMI 1.4 TMDS Electrical	8-4 Termination Voltage	Pass
	8-5 Min/Max Differential Swing Tolerance	Pass
	8-6 Intra-pair Skew	Pass
	8-7 Jitter Tolerance	Pass
	8-8 Differential Impedance	Pass
	8-21 Audio Clock Regeneration	Pass
	8-22 Audio Sample Packet Jitter	Pass
	8-23 Audio Formats	Pass
	8-24 DVI Interoperability	Pass
	8-25 Deep Color	Pass
	8-28 One Bit Audio	Pass
	8-29 3D Video	Pass
	8-30 4K x 2K Video	Pass
8-31 Extended Colors and Contents	Pass	

Given below are some suggestion and notes that will help to pass Compliance:

1. Make sure the data pair of length pair to pair mismatch is under 2mil and select the HDMI category 3 certification connector for pass the HDMI 2.1 and FRL HFR 2-2: Intra-Pair Skew and HFR 2-3: Inter-Pair Skew.
2. Set the redriver of EQ level under level 3 and Flat gain under 1.5 db to pass the HDMI 2.1 FRL HFR 2-5: Jitter Tolerance test.
3. Set the FRL DC Coupling mode, Mode 4 for pass the HDMI 1.4 8-8 Differential Impedance.

Given below Eye-Diagram for HDMI1.4 7-10 TP2 EQ worst cable model eye diagram on one of the Lanes:

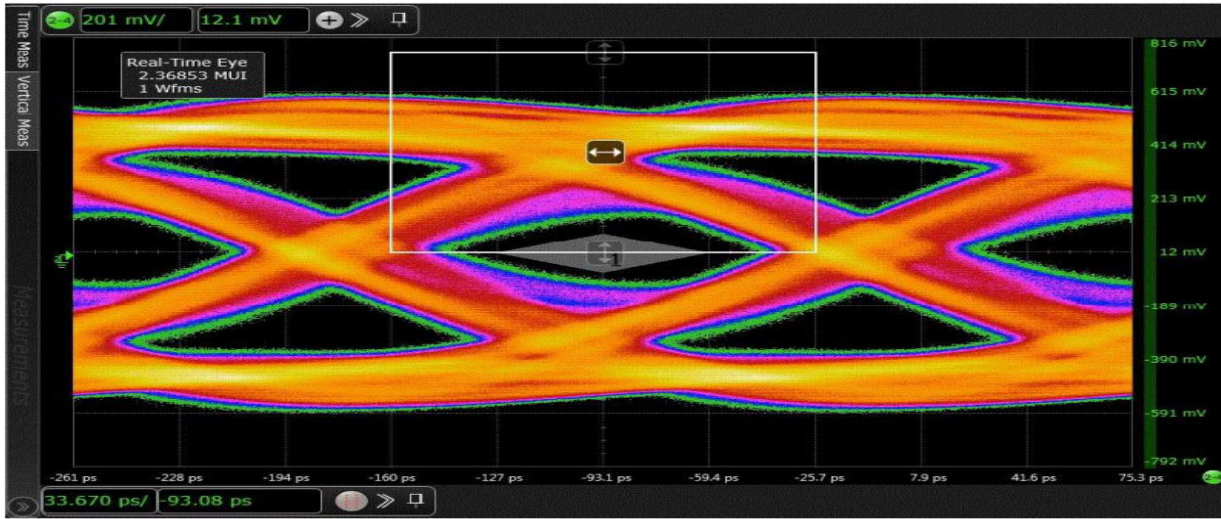

Figure 6. Eye-Diagram for HDMI 1.4 HF 7 – 10

Given below Eye-Diagram for HDMI 2.1 TMDS HF 1-8 TP2 EQ worst cable model eye diagram on one of the Lanes:

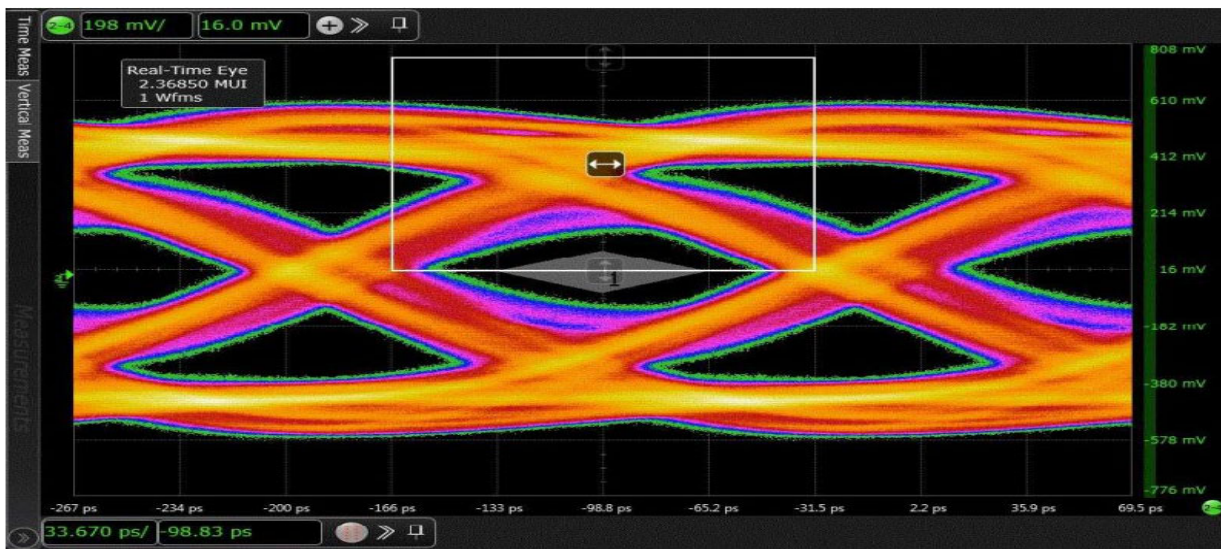

Figure 7. Eye-Diagram for HDMI 2.1 TMDS HF 1 – 8

AND90182/D

Given below Eye-Diagram for HDMI 2.1 FRL HFR 1-8 eye diagram TP3 EQ worst cable model 12 Gbps on one of the Lanes:

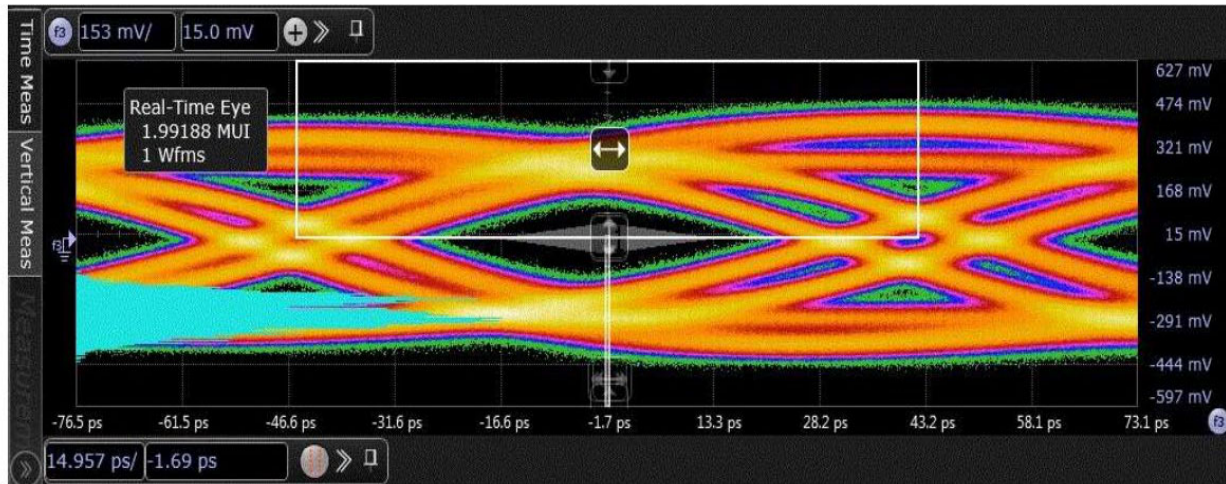

Figure 8. Eye-Diagram for HDMI 2.1 TMDS HF 1 – 8 12 Gbps

Conclusion

We can conclude that with NB7NQ621M device, it is possible to meet compliance requirement of HDMI 2.1 TMDS and FRL Mode for both the Source and Sink Side applications using the multiple I²C setting options available.

The above application note provides the details of the required redriver settings and suggestion to meet Compliance.

onsemi is licensed by the Philips Corporation to carry the I²C bus protocol.

onsemi, Onsemi, and other names, marks, and brands are registered and/or common law trademarks of Semiconductor Components Industries, LLC dba "onsemi" or its affiliates and/or subsidiaries in the United States and/or other countries. onsemi owns the rights to a number of patents, trademarks, copyrights, trade secrets, and other intellectual property. A listing of onsemi's product/patent coverage may be accessed at www.onsemi.com/site/pdf/Patent-Marking.pdf. onsemi reserves the right to make changes at any time to any products or information herein, without notice. The information herein is provided "as-is" and onsemi makes no warranty, representation or guarantee regarding the accuracy of the information, product features, availability, functionality, or suitability of its products for any particular purpose, nor does onsemi assume any liability arising out of the application or use of any product or circuit, and specifically disclaims any and all liability, including without limitation special, consequential or incidental damages. Buyer is responsible for its products and applications using onsemi products, including compliance with all laws, regulations and safety requirements or standards, regardless of any support or applications information provided by onsemi. "Typical" parameters which may be provided in onsemi data sheets and/or specifications can and do vary in different applications and actual performance may vary over time. All operating parameters, including "Typicals" must be validated for each customer application by customer's technical experts. onsemi does not convey any license under any of its intellectual property rights nor the rights of others. onsemi products are not designed, intended, or authorized for use as a critical component in life support systems or any FDA Class 3 medical devices or medical devices with a same or similar classification in a foreign jurisdiction or any devices intended for implantation in the human body. Should Buyer purchase or use onsemi products for any such unintended or unauthorized application, Buyer shall indemnify and hold onsemi and its officers, employees, subsidiaries, affiliates, and distributors harmless against all claims, costs, damages, and expenses, and reasonable attorney fees arising out of, directly or indirectly, any claim of personal injury or death associated with such unintended or unauthorized use, even if such claim alleges that onsemi was negligent regarding the design or manufacture of the part. onsemi is an Equal Opportunity/Affirmative Action Employer. This literature is subject to all applicable copyright laws and is not for resale in any manner.

PUBLICATION ORDERING INFORMATION

LITERATURE FULFILLMENT:
Email Requests to: orderlit@onsemi.com

onsemi Website: www.onsemi.com

TECHNICAL SUPPORT
North American Technical Support:
Voice Mail: 1 800-282-9855 Toll Free USA/Canada
Phone: 011 421 33 790 2910

Europe, Middle East and Africa Technical Support:
Phone: 00421 33 790 2910
For additional information, please contact your local Sales Representative